

# Allwinner H3 Datasheet

---

*Quad-Core OTT Box Processor*

**Version 1.0**

**Nov.18,2014**

## Declaration

This documentation is the original work and copyrighted property of Allwinner Technology (“Allwinner”). Reproduction in whole or in part must obtain the written approval of Allwinner and give clear acknowledgement to the copyright owner.

The information furnished by Allwinner is believed to be accurate and reliable. Allwinner reserves the right to make changes in circuit design and/or specifications at any time without notice. Allwinner does not assume any responsibility and liability for its use. Nor for any infringements of patents or other rights of the third parties which may result from its use. No license is granted by implication or otherwise under any patent or patent rights of Allwinner. This documentation neither states nor implies warranty of any kind, including fitness for any particular application.

Third party licences may be required to implement the solution/product. Customers shall be solely responsible to obtain all appropriately required third party licences. Allwinner shall not be liable for any licence fee or royalty due in respect of any required third party licence. Allwinner shall have no warranty, indemnity or other obligations with respect to matters covered under any required third party licence.

Confidential

## Revision History

Version	Date	Description
V1.0	Nov.18,2014	Initial release version

Confidential

## Table of Contents

Declaration.....	2
Revision History.....	3
Table of Contents .....	4
Chapter 1 About This Documentation .....	51
1.1. Documentation Overview .....	51
1.2. Acronyms and abbreviations.....	51
Chapter 2 Overview .....	55
2.1. Processor Features .....	56
2.1.1. CPU Architecture.....	56
2.1.2. GPU Architecture.....	56
2.1.3. Memory Subsystem.....	56
2.1.3.1. Boot ROM.....	56
2.1.3.2. SDRAM.....	56
2.1.3.3. NAND Flash .....	57
2.1.3.4. SD/MMC.....	57
2.1.4. System Peripheral.....	57
2.1.4.1. Timer .....	57
2.1.4.2. High Speed Timer .....	58
2.1.4.3. RTC .....	58
2.1.4.4. GIC.....	58
2.1.4.5. DMA .....	58

2.1.4.6.	CCU.....	58
2.1.4.7.	PWM .....	58
2.1.4.8.	Crypto Engine(CE) .....	59
2.1.4.9.	Security ID .....	59
2.1.4.10.	CPU Configuration.....	59
2.1.4.11.	Power Management .....	59
2.1.5.	Display Subsystem .....	59
2.1.5.1.	DE2.0 .....	59
2.1.5.2.	Display Output .....	60
2.1.6.	Video Engine .....	60
2.1.6.1.	Video Decoding .....	60
2.1.6.2.	Video Encoding .....	60
2.1.7.	Image Subsystem.....	61
2.1.7.1.	CSI.....	61
2.1.8.	Audio Subsystem .....	61
2.1.8.1.	Audio Codec .....	61
2.1.8.2.	One Wire Audio(OWA).....	61
2.1.8.3.	I2S/PCM.....	62
2.1.9.	External Peripherals .....	62
2.1.9.1.	USB .....	62
2.1.9.2.	Ethernet .....	62
2.1.9.3.	ADC.....	62
2.1.9.4.	CIR .....	63
2.1.9.5.	UART.....	63

2.1.9.6.	SPI.....	63
2.1.9.7.	TWI.....	63
2.1.9.8.	TS.....	63
2.1.9.9.	SCR.....	64
2.1.10.	Package.....	64
2.2.	System Block Diagram.....	65
Chapter 3	Pin Description.....	66
3.1.	Pin Characteristics.....	66
3.2.	GPIO Multiplexing Functions.....	74
3.3.	Detailed Pin/Signal Description.....	78
Chapter 4	System.....	83
4.1.	Memory Mapping.....	84
4.2.	Boot System.....	86
4.3.	CCU.....	87
4.3.1.	Overview.....	87
4.3.2.	Functionalities Description.....	87
4.3.2.1.	System Bus.....	87
4.3.2.2.	Bus clock tree.....	89
4.3.3.	Typical Applications.....	89
4.3.4.	Register List.....	90
4.3.5.	Register Description.....	92
4.3.5.1.	PLL_CPUX Control Register (Default Value: 0x00001000).....	92
4.3.5.2.	PLL_Audio Control Register (Default Value: 0x00035514).....	93
4.3.5.3.	PLL_VIDEO Control Register (Default Value: 0x03006207).....	94

4.3.5.4.	PLL_VE Control Register (Default Value: 0x03006207).....	95
4.3.5.5.	PLL_DDR Control Register (Default Value: 0x00001000).....	96
4.3.5.6.	PLL_PERIPH0 Control Register (Default Value: 0x00041811).....	97
4.3.5.7.	PLL_GPU Control Register (Default Value: 0x03006207).....	98
4.3.5.8.	PLL_PERIPH1 Control Register (Default Value: 0x00041811).....	99
4.3.5.9.	PLL_DE Control Register (Default Value: 0x03006207) .....	100
4.3.5.10.	CPUX/AXI Configuration Register (Default Value: 0x00010000) .....	101
4.3.5.11.	AHB1/APB1 Configuration Register (Default Value: 0x00001010).....	102
4.3.5.12.	APB2 Configuration Register (Default Value: 0x01000000) .....	102
4.3.5.13.	AHB2 Configuration Register (Default Value: 0x00000000) .....	103
4.3.5.14.	Bus Clock Gating Register0 (Default Value: 0x00000000) .....	103
4.3.5.15.	Bus Clock Gating Register1 (Default Value: 0x00000000) .....	105
4.3.5.16.	Bus Clock Gating Register2 (Default Value: 0x00000000) .....	106
4.3.5.17.	Bus Clock Gating Register3 (Default Value: 0x00000000) .....	107
4.3.5.18.	Bus Clock Gating Register4 (Default Value: 0x00000000) .....	108
4.3.5.19.	THS Clock Register (Default Value: 0x00000000) .....	109
4.3.5.20.	NAND Clock Register (Default Value: 0x00000000) .....	109
4.3.5.21.	SDMMC0 Clock Register (Default Value: 0x00000000) .....	110
4.3.5.22.	SDMMC1 Clock Register (Default Value: 0x00000000) .....	111
4.3.5.23.	SDMMC2 Clock Register (Default Value: 0x00000000) .....	112
4.3.5.24.	TS Clock Register (Default Value: 0x00000000) .....	113
4.3.5.25.	CE Clock Register (Default Value: 0x00000000) .....	113
4.3.5.26.	SPI0 Clock Register (Default Value: 0x00000000) .....	114
4.3.5.27.	SPI1 Clock Register (Default Value: 0x00000000) .....	114

4.3.5.28.	I2S/PCM 0 Clock Register (Default Value: 0x00000000) .....	115
4.3.5.29.	I2S/PCM 1 Clock Register (Default Value: 0x00000000) .....	116
4.3.5.30.	I2S/PCM 2 Clock Register (Default Value: 0x00000000) .....	116
4.3.5.31.	OWA Clock Register (Default Value: 0x00000000) .....	116
4.3.5.32.	USBPHY Configuration Register (Default Value: 0x00000000) .....	117
4.3.5.33.	DRAM Configuration Register (Default Value: 0x00000000).....	118
4.3.5.34.	MBUS Reset Register (Default Value: 0x80000000) .....	119
4.3.5.35.	DRAM Clock Gating Register (Default Value: 0x00000000).....	119
4.3.5.36.	DE Clock Gating Register (Default Value: 0x00000000) .....	119
4.3.5.37.	TCON0 Clock Register (Default Value: 0x00000000) .....	120
4.3.5.38.	TVE Clock Register (Default Value: 0x00000000) .....	120
4.3.5.39.	DEINTERLACE Clock Register (Default Value: 0x00000000) .....	121
4.3.5.40.	CSI_MISC Clock Register (Default Value: 0x00000000) .....	121
4.3.5.41.	CSI Clock Register (Default Value: 0x00000000) .....	121
4.3.5.42.	VE Clock Register (Default Value: 0x00000000) .....	122
4.3.5.43.	AC Digital Clock Register (Default Value: 0x00000000).....	123
4.3.5.44.	AVS Clock Register (Default Value: 0x00000000) .....	123
4.3.5.45.	HDMI Clock Register (Default Value: 0x00000000) .....	123
4.3.5.46.	HDMI Slow Clock Register (Default Value: 0x00000000) .....	124
4.3.5.47.	MBUS Clock Register (Default Value: 0x00000000) .....	124
4.3.5.48.	GPU Clock Register (Default Value: 0x00000000) .....	124
4.3.5.49.	PLL Stable Time Register0 (Default Value: 0x000000FF).....	125
4.3.5.50.	PLL Stable Time Register1 (Default Value: 0x000000FF).....	125
4.3.5.51.	PLL_CPUX Bias Register (Default Value: 0x08100200) .....	125



4.3.5.52.	PLL_AUDIO Bias Register (Default Value: 0x10100000) .....	126
4.3.5.53.	PLL_VIDEO Bias Register (Default Value: 0x10100000).....	126
4.3.5.54.	PLL_VE Bias Register (Default Value: 0x10100000).....	126
4.3.5.55.	PLL_DDR Bias Register (Default Value: 0x81104000) .....	127
4.3.5.56.	PLL_PERIPH0 Bias Register (Default Value: 0x10100010) .....	127
4.3.5.57.	PLL_GPU Bias Register (Default Value: 0x10100000).....	128
4.3.5.58.	PLL_PERIPH1 Bias Register (Default Value: 0x10100010) .....	128
4.3.5.59.	PLL_DE Bias Register (Default Value: 0x10100000).....	129
4.3.5.60.	PLL_CPUX Tuning Register (Default Value: 0x0A101000).....	129
4.3.5.61.	PLL_DDR Tuning Register (Default Value: 0x14880000).....	130
4.3.5.62.	PLL_CPUX Pattern Control Register (Default Value: 0x00000000) .....	130
4.3.5.63.	PLL_AUDIO Pattern Control Register(Default Value: 0x00000000) .....	131
4.3.5.64.	PLL_VIDEO Pattern Control Register (Default Value: 0x00000000).....	131
4.3.5.65.	PLL_VE Pattern Control Register (Default Value: 0x00000000).....	132
4.3.5.66.	PLL_DDR Pattern Control Register (Default Value: 0x00000000).....	132
4.3.5.67.	PLL_GPU Pattern Control Register (Default Value: 0x00000000).....	133
4.3.5.68.	PLL_PERIPH1 Pattern Control Register (Default Value: 0x00000000) .....	133
4.3.5.69.	PLL_DE Pattern Control Register (Default Value: 0x00000000) .....	134
4.3.5.70.	Bus Software Reset Register 0 (Default Value: 0x00000000) .....	134
4.3.5.71.	Bus Software Reset Register 1 (Default Value: 0x00000000) .....	137
4.3.5.72.	Bus Software Reset Register 2 (Default Value: 0x00000000) .....	138
4.3.5.73.	Bus Software Reset Register 3 (Default Value: 0x00000000) .....	138
4.3.5.74.	Bus Software Reset Register 4 (Default Value: 0x00000000) .....	139
4.3.5.75.	CCU Security Switch Register (Default Value: 0x00000000).....	140

4.3.5.76.	PS Control Register (Default Value: 0x00000000) .....	140
4.3.5.77.	PS Counter Register (Default Value: 0x00000000) .....	141
4.3.6.	Programming Guidelines .....	142
4.3.6.1.	PLL .....	142
4.3.6.2.	BUS .....	142
4.3.6.3.	Clock Switch .....	142
4.3.6.4.	Gating and reset .....	142
4.4.	CPU Configuration .....	143
4.4.1.	Overview .....	143
4.4.2.	Register List .....	143
4.4.3.	Register Description .....	144
4.4.3.1.	CPUS Reset Control Register(Default Value: 0x00000000).....	144
4.4.3.2.	CPU0 Reset Control Register(Default Value: 0x00000000) .....	144
4.4.3.3.	CPU0 Control Register(Default Value: 0x00000000) .....	144
4.4.3.4.	CPU0 Status Register (Default Value: 0x00000000) .....	145
4.4.3.5.	CPU1 Reset Register(Default Value: 0x00000001) .....	145
4.4.3.6.	CPU1 Control Register(Default Value: 0x00000000) .....	145
4.4.3.7.	CPU1 Status Register(Default Value: 0x00000000) .....	146
4.4.3.8.	CPU2 Reset Control Register(Default Value: 0x00000001) .....	146
4.4.3.9.	CPU2 Control Register(Default Value: 0x00000000) .....	147
4.4.3.10.	CPU2 Status Register(Default Value: 0x00000000) .....	147
4.4.3.11.	CPU3 Reset Control Register(Default Value: 0x00000001) .....	147
4.4.3.12.	CPU3 Control Register(Default Value: 0x00000000) .....	148
4.4.3.13.	CPU3 Status Register(Default Value: 0x00000000) .....	148

4.4.3.14.	CPU System Reset Control Register(Default Value: 0x00000001) .....	148
4.4.3.15.	CPU Clock Gating Register(Default Value: 0x0000010F) .....	149
4.4.3.16.	General Control Register(Default Value: 0x00000020) .....	149
4.4.3.17.	Super Standby Flag Register(Default Value: 0x00000000) .....	149
4.4.3.18.	64-bit Counter Control Register(Default Value: 0x00000000) .....	150
4.4.3.19.	64-bit Counter Low Register(Default Value: 0x00000000).....	150
4.4.3.20.	64-bit Counter High Register(Default Value: 0x00000000) .....	151
4.5.	System Control .....	152
4.5.1.	Overview .....	152
4.5.2.	System Control Register List .....	152
4.5.3.	System Control Register Description .....	152
4.5.3.1.	Version Register .....	152
4.5.3.2.	EMAC Clock Register (Default Value: 0x00058000).....	153
4.6.	Timer .....	155
4.6.1.	Overview .....	155
4.6.2.	Block Diagram .....	155
4.6.3.	Timer Register List.....	156
4.6.4.	Timer Register Description.....	156
4.6.4.1.	Timer IRQ Enable Register (Default Value: 0x00000000) .....	156
4.6.4.2.	Timer IRQ Status Register (Default Value: 0x00000000) .....	157
4.6.4.3.	Timer 0 Control Register (Default Value: 0x00000004).....	157
4.6.4.4.	Timer 0 Interval Value Register .....	158
4.6.4.5.	Timer 0 Current Value Register .....	158
4.6.4.6.	Timer 1 Control Register (Default Value: 0x00000004).....	158

4.6.4.7.	Timer 1 Interval Value Register .....	159
4.6.4.8.	Timer 1 Current Value Register .....	160
4.6.4.9.	AVS Counter Control Register (Default Value: 0x00000000) .....	160
4.6.4.10.	AVS Counter 0 Register (Default Value: 0x00000000) .....	160
4.6.4.11.	AVS Counter 1 Register (Default Value: 0x00000000) .....	161
4.6.4.12.	AVS Counter Divisor Register (Default Value: 0x05DB05DB) .....	161
4.6.4.13.	Watchdog0 IRQ Enable Register (Default Value: 0x00000000) .....	162
4.6.4.14.	Watchdog0 Status Register (Default Value: 0x00000000) .....	162
4.6.4.15.	Watchdog0 Control Register (Default Value: 0x00000000) .....	162
4.6.4.16.	Watchdog0 Configuration Register (Default Value: 0x00000001) .....	163
4.6.4.17.	Watchdog0 Mode Register (Default Value: 0x00000000) .....	163
4.6.5.	Programming Guidelines .....	164
4.6.5.1.	Timer .....	164
4.6.5.2.	Watchdog Reset .....	164
4.6.5.3.	Watchdog Restart .....	164
4.7.	Trusted Watchdog .....	165
4.7.1.	Overview .....	165
4.7.2.	Block Diagram .....	165
4.7.3.	Functionalities Description .....	165
4.7.3.1.	TWD Reset .....	165
4.7.3.2.	NV-Counter .....	166
4.7.4.	TWD Register List .....	166
4.7.5.	TWD Register Description .....	167
4.7.5.1.	TWD Status Register (Default Value: 0x00000000) .....	167

4.7.5.2.	TWD Control Register (Default Value: 0x00000000) .....	167
4.7.5.3.	TWD Restart Register (Default Value: 0x00000000) .....	168
4.7.5.4.	TWD Low Counter Register (Default Value: 0x00000000) .....	168
4.7.5.5.	TWD High Counter Register (Default Value: 0x00000000) .....	168
4.7.5.6.	TWD Interval Value Register (Default Value: 0x00000000) .....	168
4.7.5.7.	TWD Low Counter Compare Register (Default Value: 0x00000000) .....	168
4.7.5.8.	TWD High Counter Compare Register (Default Value: 0x00000000) .....	169
4.7.5.9.	Secure Storage NV-Counter Register (Default Value: 0x00000000) .....	169
4.7.5.10.	Synchronize Data Counter Register 0 (Default Value: 0x00000000) .....	169
4.7.5.11.	Synchronize Data Counter Register 1 (Default Value: 0x00000000) .....	169
4.7.5.12.	Synchronize Data Counter Register 2 (Default Value: 0x00000000) .....	169
4.7.5.13.	Synchronize Data Counter Register 3 (Default Value: 0x00000000) .....	170
4.8.	RTC .....	171
4.8.1.	Overview .....	171
4.8.2.	RTC Register List .....	171
4.8.3.	RTC Register Description .....	172
4.8.3.1.	LOSC Control Register (Default Value: 0x00004000) .....	172
4.8.3.2.	LOSC Auto Switch Status Register (Default Value: 0x00000000) .....	173
4.8.3.3.	Internal OSC Clock Prescaler Register (Default Value: 0x0000000F) .....	173
4.8.3.4.	RTC YY-MM-DD Register (Default Value: 0x00000000) .....	173
4.8.3.5.	RTC HH-MM-SS Register (Default Value: 0x00000000) .....	174
4.8.3.6.	Alarm 0 Counter Register (Default Value: 0x00000000) .....	175
4.8.3.7.	Alarm 0 Current Value Register .....	175
4.8.3.8.	Alarm 0 Enable Register (Default Value: 0x00000000) .....	175

4.8.3.9.	Alarm 0 IRQ Enable Register (Default Value: 0x00000000).....	175
4.8.3.10.	Alarm 0 IRQ Status Register (Default Value: 0x00000000).....	176
4.8.3.11.	Alarm 1 Week HH-MM-SS Register (Default Value: 0x00000000) .....	176
4.8.3.12.	Alarm 1 Enable Register (Default Value: 0x00000000) .....	176
4.8.3.13.	Alarm 1 IRQ Enable Register (Default Value: 0x00000000).....	178
4.8.3.14.	Alarm 1 IRQ Status Register (Default Value: 0x00000000).....	178
4.8.3.15.	Alarm Config Register (Default Value: 0x00000000) .....	178
4.8.3.16.	LOSC Output Gating Register (Default Value: 0x00000000).....	178
4.8.3.17.	General Purpose Register (Default Value: 0x00000000).....	179
4.8.3.18.	RTC Debug Register (Default Value: 0x00000000) .....	179
4.8.3.19.	GPL Hold Output Register (Default Value: 0x00000000).....	179
4.8.3.20.	VDD RTC Regulation Register (Default Value: 0x00000004).....	181
4.8.3.21.	IC Characteristic Register (Default Value: 0x00000000).....	181
4.9.	High-speed Timer.....	183
4.9.1.	Overview .....	183
4.9.2.	Operation Principle .....	183
4.9.2.1.	HSTimer clock gating and software reset.....	183
4.9.2.2.	HSTimer reload bit .....	183
4.9.3.	HSTimer Register List .....	183
4.9.4.	HSTimer Register Description .....	184
4.9.4.1.	HS Timer IRQ Enable Register (Default Value: 0x00000000) .....	184
4.9.4.2.	HS Timer IRQ Status Register (Default Value: 0x00000000) .....	184
4.9.4.3.	HS Timer Control Register (Default Value: 0x00000000) .....	184
4.9.4.4.	HS Timer Interval Value Lo Register .....	185

4.9.4.5.	HS Timer Interval Value Hi Register .....	185
4.9.4.6.	HS Timer Current Value Lo Register .....	186
4.9.4.7.	HS Timer Current Value Hi Register .....	186
4.9.5.	Programming Guidelines .....	186
4.10.	PWM.....	187
4.10.1.	Overview .....	187
4.10.2.	PWM Block Diagram.....	187
4.10.3.	PWM Register List .....	187
4.10.4.	PWM Register Description .....	188
4.10.4.1.	PWM Control Register(Default Value: 0x00000000).....	188
4.10.4.2.	PWM Channel 0 Period Register(Default Value: 0x00000000) .....	190
4.10.4.3.	PWM Channel 1 Period Register .....	191
4.11.	DMA .....	192
4.11.1.	Overview .....	192
4.11.2.	Functionalities Description.....	192
4.11.2.1.	Block Diagram .....	192
4.11.2.2.	DRQ Type and Corresponding Relation .....	193
4.11.2.3.	DMA Descriptor.....	193
4.11.3.	DMA Register List .....	194
4.11.4.	DMA Register Description .....	195
4.11.4.1.	DMA IRQ Enable Register0 (Default Value: 0x00000000) .....	195
4.11.4.2.	DMA IRQ Enable Register1 (Default Value: 0x00000000) .....	197
4.11.4.3.	DMA IRQ Pending Status Register0 (Default Value: 0x00000000) .....	198
4.11.4.4.	DMA IRQ Pending Status Register1 (Default Value: 0x00000000) .....	200

4.11.4.5.	DMA Security Register (Default Value: 0x00000000).....	201
4.11.4.6.	DMA Auto Gating Register (Default Value: 0x00000000).....	203
4.11.4.7.	DMA Status Register (Default Value: 0x00000000).....	203
4.11.4.8.	DMA Channel Enable Register (Default Value: 0x00000000).....	204
4.11.4.9.	DMA Channel Pause Register (Default Value: 0x00000000).....	205
4.11.4.10.	DMA Channel Descriptor Address Register (Default Value: 0x00000000).....	205
4.11.4.11.	DMA Channel Configuration Register (Default Value: 0x00000000).....	205
4.11.4.12.	DMA Channel Current Source Address Register (Default Value: 0x00000000).....	206
4.11.4.13.	DMA Channel Current Destination Address Register (Default Value: 0x00000000).....	206
4.11.4.14.	DMA Channel Byte Counter Left Register (Default Value: 0x00000000).....	206
4.11.4.15.	DMA Channel Parameter Register (Default Value: 0x00000000).....	207
4.11.4.16.	DMA Former Descriptor Address Register (Default Value: 0x00000000).....	207
4.11.4.17.	DMA Package Number Register (Default Value: 0x00000000).....	207
4.12.	GIC.....	208
4.12.1.	Interrupt Source.....	208
4.13.	Message Box.....	212
4.13.1.	Overview.....	212
4.13.2.	Functionalities Description.....	212
4.13.2.1.	Typical Applications.....	213
4.13.2.2.	Functional Block Diagram.....	214
4.13.3.	Operation Principle.....	214
4.13.3.1.	Message Queue Assignment.....	214
4.13.3.2.	Interrupt request.....	215
4.13.4.	Message Box Register List.....	215



4.13.5.	Message Box Register Description .....	216
4.13.5.1.	MSGBox Control Register 0(Default Value: 0x10101010) .....	216
4.13.5.2.	MSGBox Control Register 1(Default Value: 0x10101010) .....	217
4.13.5.3.	MSGBox IRQ Enable Register (Default Value: 0x00000000).....	218
4.13.5.4.	MSGBox IRQ Status Register u(Default Value: 0x0000AAAA).....	219
4.13.5.5.	MSGBox FIFO Status Register m(Default Value: 0x00000000) .....	221
4.13.5.6.	MSGBox Message Status Register m(Default Value: 0x00000000) .....	221
4.13.5.7.	MSGBox Message Queue Register (Default Value: 0x00000000) .....	221
4.14.	Spinlock .....	223
4.14.1.	Overview .....	223
4.14.2.	Functionalities Description.....	224
4.14.2.1.	Typical Applications .....	224
4.14.2.2.	Functional Block Diagram.....	224
4.14.3.	Operation Principle .....	225
4.14.3.1.	Spinlock clock gating and software reset .....	225
4.14.3.2.	Take and free a spinlock .....	225
4.14.4.	Spinlock Register List.....	225
4.14.5.	Spinlock Register Description.....	225
4.14.5.1.	Spinlock System Status Register (Default Value: 0x10000000) .....	225
4.14.5.2.	Spinlock Register Status (Default Value: 0x00000000).....	226
4.14.5.3.	Spinlock Register N (N=0 to 31)(Default Value: 0x00000000).....	226
4.14.6.	Programming Guidelines.....	227
4.15.	Crypto Engine .....	228
4.15.1.	Overview .....	228

4.15.2.	Functionalities Description.....	228
4.15.2.1.	Block Diagram .....	229
4.15.2.2.	Crypto Engine Task Descriptor.....	229
4.15.3.	Crypto Engine Register List.....	233
4.15.4.	Crypto Engine Register Description.....	234
4.15.4.1.	Crypto Engine Task Descriptor Queue Register(Default Value: 0x00000000).....	234
4.15.4.2.	Crypto Engine Control Register(Default Value: 0x00000000) .....	234
4.15.4.3.	Crypto Engine Interrupt Control Register(Default Value: 0x00000000).....	234
4.15.4.4.	Crypto Engine Interrupt Status Register(Default Value: 0x00000000).....	235
4.15.4.5.	Crypto Engine Task Load Register(Default Value: 0x00000000) .....	235
4.15.4.6.	Crypto Engine Task Status Register(Default Value: 0x00000000) .....	235
4.15.4.7.	Crypto Engine Error Status Register(Default Value: 0x00000000) .....	236
4.15.4.8.	Crypto Engine Current Source Scatter Group Register(Default Value: 0x00000000).....	236
4.15.4.9.	Crypto Engine Current Destination Scatter Group Register(Default Value: 0x00000000) .....	236
4.15.4.10.	Crypto Engine Current Source Address Register(Default Value: 0x00000000) .....	236
4.15.4.11.	Crypto Engine Current Destination Address Register(Default Value: 0x00000000).....	237
4.15.4.12.	Crypto Engine Throughput Register(Default Value: 0x00000000) .....	237
4.15.5.	Crypto Engine Clock Requirement.....	237
4.16.	Security ID .....	238
4.16.1.	Overview .....	238
4.17.	Secure Memory Controller .....	239
4.17.1.	Overview .....	239
4.17.2.	Functionalities Description.....	239
4.17.2.1.	DRM Block Diagram .....	240

4.17.2.2.	Master ID Table .....	240
4.17.2.3.	Region Size Table.....	241
4.17.2.4.	Security inversion is disabled .....	241
4.17.2.5.	Security inversion is enabled.....	242
4.17.3.	SMC Register List .....	242
4.17.4.	SMC Register Description .....	243
4.17.4.1.	SMC Configuration Register(Default Value: 0x00001F0F).....	243
4.17.4.2.	SMC Action Register(Default Value: 0x00000001).....	243
4.17.4.3.	SMC Lockdown Range Register(Default Value: 0x00000000) .....	244
4.17.4.4.	SMC Lockdown Select Register(Default Value: 0x00000000) .....	244
4.17.4.5.	SMC Interrupt Status Register(Default Value: 0x00000000).....	245
4.17.4.6.	SMC Interrupt Clear Register(Default Value: 0x00000000) .....	245
4.17.4.7.	SMC Master Bypass Register(Default Value: 0xFFFFFFFF) .....	245
4.17.4.8.	SMC Master Secure Register(Default Value: 0x00000000).....	245
4.17.4.9.	SMC Fail Address Register(Default Value: 0x00000000) .....	246
4.17.4.10.	SMC Fail Control Register(Default Value: 0x00000000).....	246
4.17.4.11.	SMC Fail ID Register(Default Value: 0x00001F00) .....	247
4.17.4.12.	SMC Speculation Control Register(Default Value: 0x00000000) .....	247
4.17.4.13.	SMC Security Inversion Enable Register(Default Value: 0x00000000).....	247
4.17.4.14.	SMC Master Attribute Register(Default Value: 0x00000000) .....	248
4.17.4.15.	DRM Master Enable Register(Default Value: 0x00000000) .....	248
4.17.4.16.	DRM Illegal Access Register(Default Value: 0x00000000) .....	248
4.17.4.17.	DRM Start Address Register(Default Value: 0x00000000).....	249
4.17.4.18.	DRM End Address Register(Default Value: 0x00000000).....	249

4.17.4.19.	SMC Region Setup Low Register(Default Value: 0x00000000) .....	249
4.17.4.20.	SMC Region Setup High Register(Default Value: 0x00000000).....	249
4.17.4.21.	SMC Region Attributes Register(Default Value: 0x00000000) .....	250
4.18.	Secure Memory Touch Arbiter .....	251
4.18.1.	Overview .....	251
4.18.2.	Functionalities Description.....	251
4.18.2.1.	Typical Applications .....	251
4.18.2.2.	SMTA Configuration Table .....	251
4.18.3.	SMTA Register List .....	252
4.18.4.	SMTA Register Description .....	252
4.18.4.1.	SMTA DECPOR0 Status Register(Default Value: 0x00000000) .....	252
4.18.4.2.	SMTA DECPOR0 Set Register(Default Value: 0x00000000) .....	252
4.18.4.3.	SMTA DECPOR0 Clear Register(Default Value: 0x00000000) .....	253
4.18.4.4.	SMTA DECPOR1 Status Register(Default Value: 0x00000000) .....	253
4.18.4.5.	SMTA DECPOR1 Set Register(Default Value: 0x00000000) .....	253
4.18.4.6.	SMTA DECPOR1 Clear Register(Default Value: 0x00000000) .....	254
4.18.4.7.	SMTA DECPOR2 Status Register(Default Value: 0x00000000) .....	254
4.18.4.8.	SMTA DECPOR2 Set Register(Default Value: 0x00000000) .....	254
4.18.4.9.	SMTA DECPOR2 Clear Register(Default Value: 0x00000000) .....	254
4.19.	Thermal Sensor Controller .....	256
4.19.1.	Overview .....	256
4.19.2.	Clock and Timing Requirements .....	256
4.19.3.	Thermal Sensor Register List .....	256
4.19.4.	Thermal Sensor Register Description .....	257

4.19.4.1.	THS Control Register0 (Default Value: 0x00000000) .....	257
4.19.4.2.	THS Control Register1 (Default Value: 0x00000000) .....	257
4.19.4.3.	ADC calibration Data Register (Default Value: 0x00000000) .....	258
4.19.4.4.	THS Control Register2 (Default Value: 0x00040000) .....	258
4.19.4.5.	THS Interrupt Control Register (Default Value: 0x00000000).....	258
4.19.4.6.	THS status Register (Default Value: 0x00000000) .....	259
4.19.4.7.	Alarm threshold Control Register (Default Value: 0x05a00684) .....	260
4.19.4.8.	Shutdown threshold Control Register (Default Value: 0x04e90000) .....	260
4.19.4.9.	Average filter Control Register (Default Value: 0x00000001) .....	260
4.19.4.10.	Thermal Sensor calibration Data Register (Default Value: 0x00000800) .....	260
4.19.4.11.	THS Data Register (Default Value: 0x00000000) .....	261
4.19.5.	Programming Guidelines .....	261
4.20.	KEY_ADC.....	262
4.20.1.	Overview .....	262
4.20.2.	Operation Principle .....	262
4.20.3.	KEY_ADC Register List.....	263
4.20.4.	KEY_ADC Register Description.....	263
4.20.4.1.	KEY_ADC Control Register (Default Value: 0x01000168) .....	263
4.20.4.2.	KEY_ADC Interrupt Control Register (Default Value: 0x00000000).....	264
4.20.4.3.	KEY_ADC Interrupt Status Register (Default Value: 0x00000000).....	265
4.20.4.4.	KEY_ADC Data Register (Default Value: 0x00000000).....	266
4.21.	Audio Codec .....	267
4.21.1.	Overview .....	267
4.21.2.	Power and Signal Description.....	267

4.21.2.1.	Analog I/O Pins.....	267
4.21.2.2.	Filter/Reference .....	268
4.21.2.3.	Power/Ground.....	268
4.21.3.	Data Path Diagram .....	268
4.21.4.	Audio Codec Register List .....	268
4.21.5.	Audio Codec Register Description .....	272
4.21.5.1.	0x00 DAC Digital Part Control Register(Default Value: 0x00000000).....	272
4.21.5.2.	0x04 DAC FIFO Control Register(Default Value: 0x00000F00) .....	273
4.21.5.3.	0x08 DAC FIFO Status Register(Default Value: 0x00800088) .....	275
4.21.5.4.	0x10 ADC FIFO Control Register(Default Value: 0x00000F00) .....	275
4.21.5.5.	0x14 ADC FIFO Status Register(Default Value: 0x00000000) .....	277
4.21.5.6.	0x18 ADC RX DATA Register(Default Value: 0x00000000).....	278
4.21.5.7.	0x20 DAC TX DATA Register(Default Value: 0x00000000) .....	278
4.21.5.8.	0x40 DAC TX Counter Register(Default Value: 0x00000000) .....	278
4.21.5.9.	0x44 ADC RX Counter Register(Default Value: 0x00000000) .....	278
4.21.5.10.	0x48 DAC Debug Register(Default Value: 0x00000000).....	279
4.21.5.11.	0x4C ADC Debug Register(Default Value: 0x00000000).....	279
4.21.5.12.	0x60 DAC DAP Control Register(Default Value: 0x00000000).....	280
4.21.5.13.	0x70 ADC DAP Control Register(Default Value: 0x00000000).....	280
4.21.5.14.	0x74 ADC DAP Left Control Register(Default Value: 0x001F7000).....	281
4.21.5.15.	0x78 ADC DAP Right Control Register(Default Value: 0x001F7000).....	282
4.21.5.16.	0x7C ADC DAP Parameter Register(Default Value: 0x2C2C2828) .....	284
4.21.5.17.	0x80 ADC DAP Left Average Coef Register(Default Value: 0x00051EB8) .....	284
4.21.5.18.	0x84 ADC DAP Left Decay & Attack Time Register(Default Value: 0x0000_001F) .....	284

4.21.5.19.	0x88 ADC DAP Right Average Coef Register(Default Value: 0x00051EB8) .....	285
4.21.5.20.	0x8C ADC DAP Right Decay & Attack Time Register(Default Value: 0x0000001F) .....	285
4.21.5.21.	0x90 ADC DAP HPF Coef Register(Default Value: 0x00FF_FAC1) .....	286
4.21.5.22.	0x94 ADC DAP Left Input Signal Low Average Coef Register(Default Value: 0x00051EB8) ...	286
4.21.5.23.	0x98 ADC DAP Right Input Signal Low Average Coef Register(Default Value: 0x00051EB8).	286
4.21.5.24.	0x9C ADC DAP Optimum Register(Default Value: 0x00000000) .....	286
4.21.5.25.	0x100 DAC DRC High HPF Coef Register(Default Value: 0x000000FF) .....	287
4.21.5.26.	0x104 DAC DRC Low HPF Coef Register(Default Value: 0x0000FAC1) .....	287
4.21.5.27.	0x108 DAC DRC Control Register(Default Value: 0x00000080) .....	287
4.21.5.28.	0x10C DAC DRC Left Peak Filter High Attack Time Coef Register(Default Value: 0x0000_000B) 289	
4.21.5.29.	0x110 DAC DRC Left Peak Filter Low Attack Time Coef Register(Default Value: 0x000077BF) 289	
4.21.5.30.	0x114 DAC DRC Right Peak Filter High Attack Time Coef Register(Default Value: 0x0000000B) 289	
4.21.5.31.	0x118 DAC DRC Peak Filter Low Attack Time Coef Register(Default Value: 0x000077BF) ...	289
4.21.5.32.	0x11C DAC DRC Left Peak Filter High Release Time Coef Register(Default Value: 0x000000FF) 290	
4.21.5.33.	0x120 DAC DRC Left Peak Filter Low Release Time Coef Register(Default Value: 0x0000E1F8) 290	
4.21.5.34.	0x124 DAC DRC Right Peak filter High Release Time Coef Register(Default Value: 0x0000_00FF) .....	290
4.21.5.35.	0x128 DAC DRC Right Peak filter Low Release Time Coef Register(Default Value: 0x0000E1F8) 290	
4.21.5.36.	0x12C DAC DRC Left RMS Filter High Coef Register(Default Value: 0x00000001) .....	290
4.21.5.37.	0x130 DAC DRC Left RMS Filter Low Coef Register(Default Value: 0x00002BAF) .....	291
4.21.5.38.	0x134 DAC DRC Right RMS Filter High Coef Register(Default Value: 0x00000001) .....	291
4.21.5.39.	0x138 DAC DRC Right RMS Filter Low Coef Register(Default Value: 0x00002BAF) .....	291

4.21.5.40.	0x13C DAC DRC Compressor Threshold High Setting Register(Default Value: 0x000006A4) 291	
4.21.5.41.	0x140 DAC DRC Compressor Threshold High Setting Register(Default Value: 0x0000_D3C0) 291	
4.21.5.42.	0x144 DAC DRC Compressor Slope High Setting Register(Default Value: 0x00000080) .....	292
4.21.5.43.	0x148 DAC DRC Compressor Slope Low Setting Register(Default Value: 0x0000_0000) .....	292
4.21.5.44.	0x14C DAC DRC Compressor High Output at Compressor Threshold Register( Default Value: 0x0000F95B) .....	292
4.21.5.45.	0x150 DAC DRC Compressor Low Output at Compressor Threshold Register(Default Value: 0x00002C3F).....	292
4.21.5.46.	0x154 DAC DRC Limiter Theshold High Setting Register(Default Value: 0x000001A9) .....	292
4.21.5.47.	0x158 DAC DRC Limiter Theshold Low Setting Register(Default Value: 0x0000_34F0).....	293
4.21.5.48.	0x15C DAC DRC Limiter Slope High Setting Register(Default Value: 0x0000_0005) .....	293
4.21.5.49.	0x160 DAC DRC Limiter Slope Low Setting Register(Default Value: 0x00001EB8) .....	293
4.21.5.50.	0x164 DAC DRC Limiter High Output at Limiter Threshold(Default Value: 0x0000FBD8) ....	293
4.21.5.51.	0x168 DAC DRC Limiter Low Output at Limiter Threshold(Default Value: 0x0000FBA7) ....	293
4.21.5.52.	0x16C DAC DRC Expander Theshold High Setting Register(Default Value: 0x00000BA0) ....	294
4.21.5.53.	0x170 DAC DRC Expander Theshold Low Setting Register(Default Value: 0x00007291).....	294
4.21.5.54.	0x174 DAC DRC Expander Slope High Setting Register(Default Value: 0x00000500).....	294
4.21.5.55.	0x178 DAC DRC Expander Slope Low Setting Register(Default Value: 0x00000000).....	294
4.21.5.56.	0x17C DAC DRC Expander High Output at Expander Threshold(Default Value: 0x0000F45F) 294	
4.21.5.57.	0x180 DAC DRC Expander Low Output at Expander Threshold(Default Value: 0x00008D6E) 295	
4.21.5.58.	0x184 DAC DRC Linear Slope High Setting Register(Default Value: 0x00000100) .....	295
4.21.5.59.	0x188 DAC DRC Linear Slope Low Setting Register(Default Value: 0x00000000).....	295
4.21.5.60.	0x18C DAC DRC Smooth filter Gain High Attack Time Coef Register(Default Value: 0x00000002) .....	295



4.21.5.61. 0x190 DAC DRC Smooth filter Gain Low Attack Time Coef Register(Default Value: 0x00005600) .....	295
4.21.5.62. 0x194 DAC DRC Smooth filter Gain High Release Time Coef Register(Default Value: 0x00000000) .....	296
4.21.5.63. 0x198 DAC DRC Smooth filter Gain Low Release Time Coef Register(Default Value: 0x00000F04).....	296
4.21.5.64. 0x19C DAC DRC MAX Gain High Setting Register(Default Value: 0x0000FE56) .....	296
4.21.5.65. 0x1A0 DAC DRC MAX Gain Low Setting Register(Default Value: 0x0000CB0F) .....	296
4.21.5.66. 0x1A4 DAC DRC MIN Gain High Setting Register(Default Value: 0x0000F95B) .....	296
4.21.5.67. 0x1A8 DAC DRC MIN Gain Low Setting Register(Default Value: 0x00002C3F) .....	297
4.21.5.68. 0x1AC DAC DRC Expander Smooth Time High Coef Register(Default Value: 0x00000000)..	297
4.21.5.69. 0x1B0 DAC DRC Expander Smooth Time Low Coef Register(Default Value: 0x0000640C)...	297
4.21.5.70. 0x1B8 DAC DRC HPF Gain High Coef Register(Default Value: 0x00000100) .....	297
4.21.5.71. 0x1BC DAC DRC HPF Gain Low Coef Register(Default Value: 0x00000000).....	297
4.21.5.72. 0x200 ADC DRC High HPF Coef Register(Default Value: 0x000000FF).....	298
4.21.5.73. 0x204 ADC DRC Low HPF Coef Register(Default Value: 0x0000FAC1) .....	298
4.21.5.74. 0x208 ADC DRC Control Register(Default Value: 0x00000080) .....	298
4.21.5.75. 0x20C ADC DRC Left Peak Filter High Attack Time Coef Register(Default Value: 0x0000000B) 299	
4.21.5.76. 0x210 ADC DRC Left Peak Filter Low Attack Time Coef Register(Default Value: 0x0000_77BF) 299	
4.21.5.77. 0x214 ADC DRC Right Peak Filter High Attack Time Coef Register(Default Value: 0x0000_000B) .....	300
4.21.5.78. 0x218 ADC DRC Peak Filter Low Attack Time Coef Register(Default Value: 0x000077BF) ...	300
4.21.5.79. 0x21C ADC DRC Left Peak Filter High Release Time Coef Register(Default Value: 0x000000FF) 300	
4.21.5.80. 0x220 ADC DRC Left Peak Filter Low Release Time Coef Register(Default Value: 0x0000E1F8) 300	

4.21.5.81.	0x224 ADC DRC Right Peak filter High Release Time Coef Register(Default Value: 0x000000FF) 300	
4.21.5.82.	0x228 ADC DRC Right Peak filter Low Release Time Coef Register(Default Value: 0x0000E1F8) 301	
4.21.5.83.	0x22C ADC DRC Left RMS Filter High Coef Register(Default Value: 0x00000001).....	301
4.21.5.84.	0x230 ADC DRC Left RMS Filter Low Coef Register(Default Value: 0x00002BAF) .....	301
4.21.5.85.	0x234 ADC DRC Right RMS Filter High Coef Register(Default Value: 0x00000001).....	301
4.21.5.86.	0x238 ADC DRC Right RMS Filter Low Coef Register(Default Value: 0x00002BAF) .....	301
4.21.5.87.	0x23C ADC DRC Compressor Theshold High Setting Register(Default Value: 0x000006A4)	302
4.21.5.88.	0x240 ADC DRC Compressor Slope High Setting Register(Default Value: 0x0000D3C0).....	302
4.21.5.89.	0x244 ADC DRC Compressor Slope High Setting Register(Default Value: 0x00000080) .....	302
4.21.5.90.	0x248 ADC DRC Compressor Slope Low Setting Register(Default Value: 0x00000000) .....	302
4.21.5.91.	0x24C ADC DRC Compressor High Output at Compressor Threshold Register(Default Value: 0x0000F95B) .....	302
4.21.5.92.	0x250 ADC DRC Compressor Low Output at Compressor Threshold Register(Default Value: 0x00002C3F).....	303
4.21.5.93.	0x254 ADC DRC Limiter Theshold High Setting Register(Default Value: 0x000001A9) .....	303
4.21.5.94.	0x258 ADC DRC Limiter Theshold Low Setting Register(Default Value: 0x000034F0).....	303
4.21.5.95.	0x25C ADC DRC Limiter Slope High Setting Register(Default Value: 0x00000005) .....	303
4.21.5.96.	0x260 ADC DRC Limiter Slope Low Setting Register(Default Value: 0x1EB8) .....	303
4.21.5.97.	0x264 ADC DRC Limiter High Output at Limiter Threshold(Default Value: 0x0000FBD8) ....	304
4.21.5.98.	0x268 ADC DRC Limiter Low Output at Limiter Threshold(Default Value: 0x0000FBA7) ....	304
4.21.5.99.	0x26C ADC DRC Expander Theshold High Setting Register(Default Value: 0x00000BA0) ....	304
4.21.5.100.	0x270 ADC DRC Expander Theshold Low Setting Register(Default Value: 0x00007291).....	304
4.21.5.101.	0x274 ADC DRC Expander Slope High Setting Register(Default Value: 0x00000500).....	304
4.21.5.102.	0x278 ADC DRC Expander Slope Low Setting Register(Default Value: 0x00000000) .....	305

4.21.5.103.	0x27C ADC DRC Expander High Output at Expander Threshold(Default Value: 0x0000F45F) 305	
4.21.5.104.	0x280 ADC DRC Expander Low Output at Expander Threshold(Default Value: 0x00008D6E) 305	
4.21.5.105.	0x284 ADC DRC Linear Slope High Setting Register(Default Value: 0x00000100).....	305
4.21.5.106.	0x288 ADC DRC Linear Slope Low Setting Register(Default Value: 0x00000000).....	305
4.21.5.107.	0x28C ADC DRC Smooth filter Gain High Attack Time Coef Register(Default Value: 0x00000002) 306	
4.21.5.108.	0x290 ADC DRC Smooth filter Gain Low Attack Time Coef Register(Default Value: 0x00005600) 306	
4.21.5.109.	0x294 ADC DRC Smooth filter Gain High Release Time Coef Register(Default Value: 0x00000000) 306	
4.21.5.110.	0x298 ADC DRC Smooth filter Gain Low Release Time Coef Register(Default Value: 0x00000F04) 306	
4.21.5.111.	0x29C ADC DRC MAX Gain High Setting Register(Default Value: 0x0000FE56).....	306
4.21.5.112.	0x2A0 ADC DRC MAX Gain Low Setting Register(Default Value: 0x0000CB0F).....	307
4.21.5.113.	0x2A4 ADC DRC MIN Gain High Setting Register(Default Value: 0x0000F95B).....	307
4.21.5.114.	0x2A8 ADC DRC MIN Gain Low Setting Register(Default Value: 0x00002C3F).....	307
4.21.5.115.	0x2AC ADC DRC Expander Smooth Time High Coef Register(Default Value: 0x00000000)	307
4.21.5.116.	0x2B0 ADC DRC Expander Smooth Time Low Coef Register(Default Value: 0x0000640C)	307
4.21.5.117.	0x2B8 ADC DRC HPF Gain High Coef Register(Default Value: 0x00000100).....	308
4.21.5.118.	0x2BC ADC DRC HPF Gain Low Coef Register(Default Value: 0x00000000).....	308
4.21.6.	Audio Codec Analog Part Register Description .....	308
4.21.6.1.	AC Parameter Configuration Register (Default Value: 0x00000000).....	308
4.21.6.2.	0x00 LINEOUT PA Gating Control Register(Default Value: 0x00).....	309
4.21.6.3.	0x01 Left Output Mixer Source Select Control Register(Default Value: 0x00).....	309
4.21.6.4.	0x02 Right Output Mixer Source Select Control Register(Default Value: 0x00).....	310

4.21.6.5.	0x03 DAC Analog Enable and PA Source Control Register(Default Value: 0x00).....	310
4.21.6.6.	0x05 Linein and Gain Control Register(Default Value: 0x30) .....	310
4.21.6.7.	0x06 MIC1 And MIC2 Gain Control Register(Default Value: 0x33).....	311
4.21.6.8.	0x07 PA Enable and LINEOUT Control Register(Default Value: 0x04) .....	311
4.21.6.9.	0x09 Lineout Volume Control Register(Default Value: 0x00).....	311
4.21.6.10.	0x0A Mic2 Boost and Lineout Enable Control Register(Default Value: 0x40) .....	312
4.21.6.11.	0x0B MIC1 Boost And MICBIAS Control Register(Default Value: 0x04) .....	312
4.21.6.12.	0x0C Left ADC Mixer Source Control Register(Default Value: 0x00) .....	312
4.21.6.13.	0x0D Right ADC Mixer Source Control Register(Default Value: 0x00).....	313
4.21.6.14.	0x0E Reserved Register(Default Value: 0x04) .....	313
4.21.6.15.	0x0F ADC Analog Part Enable Register(Default Value: 0x03) .....	314
4.21.6.16.	0x10 ADDA Analog Performance Turning 0 Register(Default Value: 0x55) .....	314
4.21.6.17.	0x11 ADDA Analog Performance Turning 1 Register(Default Value: 0x45) .....	314
4.21.6.18.	0x12 ADDA Analog Performance Turning 2 Register(Default Value: 0x42) .....	315
4.21.6.19.	0x13 Bias & DA16 Calibration Control Register0(Default Value: 0xD6).....	315
4.21.6.20.	0x14 Bias & DA16 Calibration Control Register1(Default Value: 0x00) .....	316
4.21.6.21.	0x15 DA16 Calibration Data Register(Default Value: 0x80) .....	316
4.21.6.22.	0x16 DA16 Register Setting Data Register(Default Value: 0x80) .....	317
4.21.6.23.	0x17 Bias Calibration Data Register(Default Value: 0x20).....	317
4.21.6.24.	0x18 Bias Register Setting Data Register(Default Value: 0x20) .....	317
4.22.	Port Controller(CPU-PORT).....	318
4.22.1.	Port Controller Register List .....	318
4.22.2.	Port Controller Register Description .....	319
4.22.2.1.	PA Configure Register 0 (Default Value: 0x77777777) .....	319

4.22.2.2.	PA Configure Register 1 (Default Value: 0x77777777) .....	320
4.22.2.3.	PA Configure Register 2 (Default Value: 0x00777777) .....	321
4.22.2.4.	PA Configure Register 3 (Default Value: 0x00000000) .....	322
4.22.2.5.	PA Data Register (Default Value: 0x00000000) .....	322
4.22.2.6.	PA Multi-Driving Register 0 (Default Value: 0x55555555).....	323
4.22.2.7.	PA Multi-Driving Register 1 (Default Value: 0x00000555).....	323
4.22.2.8.	PA PULL Register 0 (Default Value: 0x00000000) .....	323
4.22.2.9.	PA PULL Register 1 (Default Value: 0x00000000) .....	323
4.22.2.10.	PC Configure Register 0 (Default Value: 0x77777777) .....	324
4.22.2.11.	PC Configure Register 1 (Default Value: 0x77777777) .....	325
4.22.2.12.	PC Configure Register 2 (Default Value: 0x00000777) .....	326
4.22.2.13.	PC Configure Register 3 (Default Value: 0x00000000) .....	326
4.22.2.14.	PC Data Register (Default Value: 0x00000000) .....	327
4.22.2.15.	PC Multi-Driving Register 0 (Default Value: 0x55555555) .....	327
4.22.2.16.	PC Multi-Driving Register 1 (Default Value: 0x00000015) .....	327
4.22.2.17.	PC PULL Register 0 (Default Value: 0x00005140).....	327
4.22.2.18.	PC PULL Register 1 (Default Value: 0x00000014).....	328
4.22.2.19.	PD Configure Register 0 (Default Value: 0x77777777).....	328
4.22.2.20.	PD Configure Register 1 (Default Value: 0x77777777).....	329
4.22.2.21.	PD Configure Register 2 (Default Value: 0x00000077).....	330
4.22.2.22.	PD Configure Register 3 (Default Value: 0x00000000).....	331
4.22.2.23.	PD Data Register (Default Value: 0x00000000).....	331
4.22.2.24.	PD Multi-Driving Register 0 (Default Value: 0x55555555) .....	331
4.22.2.25.	PD Multi-Driving Register 1 (Default Value: 0x00000005) .....	331

4.22.2.26.	PD PULL Register 0 (Default Value: 0x00000000).....	332
4.22.2.27.	PD PULL Register 1 (Default Value: 0x00000000).....	332
4.22.2.28.	PE Configure Register 0 (Default Value: 0x77777777) .....	332
4.22.2.29.	PE Configure Register 1 (Default Value: 0x77777777) .....	333
4.22.2.30.	PE Configure Register 2 (Default Value: 0x00000000) .....	334
4.22.2.31.	PE Configure Register 3 (Default Value: 0x00000000) .....	335
4.22.2.32.	PE Data Register (Default Value: 0x00000000) .....	335
4.22.2.33.	PE Multi-Driving Register 0 (Default Value: 0x55555555).....	335
4.22.2.34.	PE Multi-Driving Register 1 (Default Value: 0x00000000).....	335
4.22.2.35.	PE PULL Register 0 (Default Value: 0x00000000).....	335
4.22.2.36.	PE PULL Register 1 (Default Value: 0x00000000).....	336
4.22.2.37.	PF Configure Register 0 (Default Value: 0x07373733) .....	336
4.22.2.38.	PF Configure Register 1 (Default Value: 0x00000000) .....	337
4.22.2.39.	PF Configure Register 2 (Default Value: 0x00000000) .....	337
4.22.2.40.	PF Configure Register 3 (Default Value: 0x00000000) .....	337
4.22.2.41.	PF Data Register (Default Value: 0x00000000).....	337
4.22.2.42.	PF Multi-Driving Register 0 (Default Value: 0x00001555).....	338
4.22.2.43.	PF Multi-Driving Register 1 (Default Value: 0x00000000).....	338
4.22.2.44.	PF PULL Register 0 (Default Value: 0x00000000) .....	338
4.22.2.45.	PF PULL Register 1 (Default Value: 0x00000000) .....	338
4.22.2.46.	PG Configure Register 0 (Default Value: 0x77777777).....	339
4.22.2.47.	PG Configure Register 1 (Default Value: 0x00777777).....	340
4.22.2.48.	PG Configure Register 2 (Default Value: 0x00000000).....	341
4.22.2.49.	PG Configure Register 3 (Default Value: 0x00000000).....	341

4.22.2.50.	PG Data Register (Default Value: 0x00000000) .....	341
4.22.2.51.	PG Multi-Driving Register 0 (Default Value: 0x05555555) .....	341
4.22.2.52.	PG Multi-Driving Register 1 (Default Value: 0x00000000) .....	342
4.22.2.53.	PG PULL Register 0 (Default Value: 0x00000000) .....	342
4.22.2.54.	PG PULL Register 1 (Default Value: 0x00000000) .....	342
4.22.2.55.	PA External Interrupt Configure Register 0 (Default Value: 0x00000000).....	342
4.22.2.56.	PA External Interrupt Configure Register 1 (Default Value: 0x00000000).....	342
4.22.2.57.	PA External Interrupt Configure Register 2 (Default Value: 0x00000000).....	343
4.22.2.58.	PA External Interrupt Configure Register 3 (Default Value: 0x00000000).....	343
4.22.2.59.	PA External Interrupt Control Register (Default Value: 0x00000000) .....	343
4.22.2.60.	PA External Interrupt Status Register (Default Value: 0x00000000) .....	344
4.22.2.61.	PA External Interrupt Debounce Register (Default Value: 0x00000000).....	344
4.22.2.62.	PG External Interrupt Configure Register 0 (Default Value: 0x00000000) .....	344
4.22.2.63.	PG External Interrupt Configure Register 1 (Default Value: 0x00000000) .....	345
4.22.2.64.	PG External Interrupt Configure Register 2 (Default Value: 0x00000000) .....	345
4.22.2.65.	PG External Interrupt Configure Register 3 (Default Value: 0x00000000) .....	345
4.22.2.66.	PG External Interrupt Control Register (Default Value: 0x00000000).....	345
4.22.2.67.	PG External Interrupt Status Register (Default Value: 0x00000000).....	345
4.22.2.68.	PG External Interrupt Debounce Register (Default Value: 0x00000000) .....	346
4.23.	Port Controller(CPU-S-PORT) .....	347
4.23.1.	Port Controller Register List .....	347
4.23.2.	Port Controller Register Description .....	347
4.23.2.1.	PL Configure Register 0 (Default Value: 0x77777777).....	347
4.23.2.2.	PL Configure Register 1 (Default Value: 0x00007777).....	349

4.23.2.3.	PL Configure Register 2 (Default Value: 0x00000000).....	349
4.23.2.4.	PL Configure Register 3 (Default Value: 0x00000000).....	349
4.23.2.5.	PL Data Register (Default Value: 0x00000000).....	350
4.23.2.6.	PL Multi-Driving Register 0 (Default Value: 0x00555555).....	350
4.23.2.7.	PL Multi-Driving Register 1 (Default Value: 0x00000000).....	350
4.23.2.8.	PL PULL Register 0 (Default Value: 0x00000005).....	350
4.23.2.9.	PL PULL Register 1 (Default Value: 0x00000000).....	351
4.23.2.10.	PL External Interrupt Configure Register 0 (Default Value: 0x00000000).....	351
4.23.2.11.	PL External Interrupt Configure Register 1 (Default Value: 0x00000000).....	351
4.23.2.12.	PL External Interrupt Configure Register 2 (Default Value: 0x00000000).....	351
4.23.2.13.	PL External Interrupt Configure Register 3 (Default Value: 0x00000000).....	352
4.23.2.14.	PL External Interrupt Control Register (Default Value: 0x00000000).....	352
4.23.2.15.	PL External Interrupt Status Register (Default Value: 0x00000000).....	352
4.23.2.16.	PL External Interrupt Debounce Register (Default Value: 0x00000000).....	352
Chapter 5	Memory.....	353
5.1.	SDRAM.....	353
5.1.1.	Overview.....	353
5.2.	NAND Flash.....	354
5.2.1.	Overview.....	354
5.2.2.	Block Diagram.....	354
5.2.3.	NDFC Timing Diagram.....	355
5.2.4.	NDFC Operation Guide.....	362
5.2.5.	NDFC Register List.....	363
5.2.6.	NDFC Register Description.....	364



5.2.6.1.	NDFC Control Register(Default Value: 0x00000000).....	364
5.2.6.2.	NDFC Status Register(Default Value: 0x00000000).....	366
5.2.6.3.	NDFC Interrupt and DMA Enable Register(Default Value: 0x00000000) .....	367
5.2.6.4.	NDFC Timing Control Register(Default Value: 0x00000000).....	368
5.2.6.5.	NDFC Timing Configure Register(Default Value: 0x00000095).....	368
5.2.6.6.	NDFC Address Low Word Register(Default Value: 0x00000000) .....	370
5.2.6.7.	NDFC Address High Word Register(Default Value: 0x00000000).....	370
5.2.6.8.	NDFC Data Block Number Register(Default Value: 0x00000000) .....	370
5.2.6.9.	NDFC Data Counter Register(Default Value: 0x00000000) .....	371
5.2.6.10.	NDFC Command IO Register(Default Value: 0x00000000) .....	371
5.2.6.11.	NDFC Command Set Register 0(Default Value: 0x00E00530) .....	373
5.2.6.12.	NDFC Command Set Register 1(Default Value: 0x70008510) .....	373
5.2.6.13.	NDFC IO Data Register(Default Value: 0x00000000).....	373
5.2.6.14.	NDFC ECC Control Register(Default Value: 0x4a800008).....	373
5.2.6.15.	NDFC ECC Status Register(Default Value: 0x00000000).....	375
5.2.6.16.	NDFC Enhanced Feature Register(Default Value: 0x00000000).....	375
5.2.6.17.	NDFC Error Counter Register 0(Default Value: 0x0000_0000).....	375
5.2.6.18.	NDFC Error Counter Register 1(Default Value: 0x00000000).....	376
5.2.6.19.	NDFC Error Counter Register 2(Default Value: 0x00000000).....	376
5.2.6.20.	NDFC Error Counter Register 3(Default Value: 0x00000000).....	376
5.2.6.21.	NDFC User Data Register [n]( Default Value: 0xffffffff) .....	377
5.2.6.22.	NDFC EFNAND STATUS Register(Default Value: 0x00000000) .....	377
5.2.6.23.	NDFC Spare Area Register(Default Value: 0x00000400) .....	377
5.2.6.24.	NDFC Pattern ID Register(Default Value: 0x00000000) .....	377

5.2.6.25.	NDFC Read Data Status Control Register(Default Value: 0x01000000).....	378
5.2.6.26.	NDFC Read Data Status Register 0(Default Value: 0x00000000).....	378
5.2.6.27.	NDFC Read Data Status Register 1(Default Value: 0x00000000).....	378
5.2.6.28.	NDFC MBUS DMA Address Register(Default Value: 0x00000000).....	379
5.2.6.29.	NDFC MBUS DMA Byte Counter Register(Default Value: 0x00000000).....	379
5.3.	SD/MMC.....	380
5.3.1.	Overview .....	380
5.3.2.	Block Diagram .....	381
5.3.3.	SD/MMC Controller Timing Diagram .....	381
5.3.4.	SD/MMC Controller Special Requirement.....	381
5.3.4.1.	SD/MMC Pin List .....	381
5.3.5.	Internal DMA Controller Description .....	382
5.3.5.1.	IDMAC Descriptor Structure.....	382
5.3.5.2.	DES0 definition.....	383
5.3.5.3.	DES1 definition.....	384
5.3.5.4.	DES2 definition.....	384
5.3.5.5.	DES3 definition.....	384
5.3.6.	SD/MMC Register List.....	384
5.3.7.	SD/MMC Register Description.....	385
5.3.7.1.	SD Global Control Register(Default Value: 0x00000300).....	385
5.3.7.2.	SD Clock Control Register(Default Value: 0x00000000).....	386
5.3.7.3.	SD Timeout Register (Default Value: 0xFFFFF40).....	387
5.3.7.4.	SD Bus Width Register (Default Value: 0x00000000) .....	387
5.3.7.5.	SD Block Size Register (Default Value: 0x00000200).....	387

5.3.7.6.	SD Block Count Register (Default Value: 0x00000200) .....	388
5.3.7.7.	SD Command Register (Default Value: 0x00000000).....	388
5.3.7.8.	SD Command Argument Register (Default Value: 0x00000000).....	390
5.3.7.9.	SD Response 0 Register (Default Value: 0x00000000) .....	390
5.3.7.10.	SD Response 1 Register (Default Value: 0x00000000) .....	391
5.3.7.11.	SD Response 2 Register (Default Value: 0x00000000) .....	391
5.3.7.12.	SD Response 3 Register (Default Value: 0x00000000) .....	391
5.3.7.13.	SD Interrupt Mask Register (Default Value: 0x00000000) .....	391
5.3.7.14.	SD Masked Interrupt Status Register (Default Value: 0x00000000) .....	392
5.3.7.15.	SD Raw Interrupt Status Register (Default Value: 0x00000000) .....	393
5.3.7.16.	SD Status Register (Default Value: 0x00000006) .....	393
5.3.7.17.	SD FIFO Water Level Register (Default Value: 0x000F0000) .....	395
5.3.7.18.	SD Function Select Register (Default Value: 0x00000000).....	396
5.3.7.19.	SD Auto Command 12 Register (Default Value: 0x0000ffff) .....	397
5.3.7.20.	SD NewTiming Set Register (Default Value: 0x00000001,only used in SDC1/2).....	397
5.3.7.21.	SD Hardware Reset Register (Default Value: 0x00000001).....	398
5.3.7.22.	SD DMAC Control Register (Default Value: 0x00000000) .....	398
5.3.7.23.	SD Descriptor List Base Address Register (Default Value: 0x00000000) .....	399
5.3.7.24.	SD DMAC Status Register (Default Value: 0x0000_0000) .....	399
5.3.7.25.	SD DMAC Interrupt Enable Register (Default Value: 0x00000000).....	401
5.3.7.26.	Card Threshold Control Register (Default Value: 0x00000000) .....	402
5.3.7.27.	eMMC4.41 DDR Start Bit Detection Control Register (Default Value: 0x00000000) .....	402
5.3.7.28.	SD Response CRC Register (Default Value: 0x00000000).....	403
5.3.7.29.	SD Data7 CRC Register (Default Value: 0x00000000).....	403

5.3.7.30.	SD Data6 CRC Register (Default Value: 0x00000000).....	403
5.3.7.31.	SD Data5 CRC Register (Default Value: 0x00000000).....	403
5.3.7.32.	SD Data4 CRC Register (Default Value: 0x00000000).....	404
5.3.7.33.	SD Data3 CRC Register (Default Value: 0x00000000).....	404
5.3.7.34.	SD Data2 CRC Register (Default Value: 0x00000000).....	404
5.3.7.35.	SD Data1 CRC Register (Default Value: 0x00000000).....	405
5.3.7.36.	SD Data0 CRC Register (Default Value: 0x00000000).....	405
5.3.7.37.	SD CRC Status Register (Default Value: 0x00000000).....	405
5.3.7.38.	SD FIFO Register (Default Value: 0x00000000).....	405
Chapter 6	Image.....	407
6.1.	CSI.....	407
6.1.1.	Overview .....	407
6.1.2.	Functionalities Description.....	408
6.1.2.1.	Block Diagram .....	408
6.1.2.2.	CSI FIFO Distribution .....	409
6.1.2.3.	CSI Timing.....	409
6.1.2.4.	Bit Definition .....	410
6.1.3.	Register list.....	410
6.1.4.	Register Description .....	411
6.1.4.1.	CSI Enable Register (Default Value: 0x00000000).....	411
6.1.4.2.	CSI Interface Configuration Register (Default Value: 0x00000000) .....	412
6.1.4.3.	CSI Capture Register (Default Value: 0x00000000).....	413
6.1.4.4.	CSI Synchronization Counter Register (Default Value: 0x00000000) .....	414
6.1.4.5.	CSI FIFO Threshold Register (Default Value: 0x040f0400) .....	414

6.1.4.6.	CSI Pattern Generation Length Register (Default Value: 0x00000000).....	415
6.1.4.7.	CSI Pattern Generation Address Register (Default Value: 0x00000000).....	415
6.1.4.8.	CSI Version Register (Default Value: 0x00000000) .....	415
6.1.4.9.	CSI Channel_0 configuration Register (Default Value: 0x00300200).....	415
6.1.4.10.	CSI Channel_0 scale Register (Default Value: 0x00000000) .....	418
6.1.4.11.	CSI Channel_0 FIFO 0 output buffer-A address Register (Default Value: 0x00000000).....	418
6.1.4.12.	CSI Channel_0 FIFO 1 output buffer-A address Register (Default Value: 0x00000000).....	418
6.1.4.13.	CSI Channel_0 FIFO 2 output buffer-A address Register (Default Value: 0x00000000).....	418
6.1.4.14.	CSI Channel_0 status Register (Default Value: 0x00000000).....	418
6.1.4.15.	CSI Channel_0 interrupt enable Register (Default Value: 0x00000000) .....	419
6.1.4.16.	CSI Channel_0 interrupt status Register (Default Value: 0x00000000) .....	420
6.1.4.17.	CSI Channel_0 horizontal size Register (Default Value: 0x05000000) .....	420
6.1.4.18.	CSI Channel_0 vertical size Register (Default Value: 0x01E00000).....	421
6.1.4.19.	CSI Channel_0 buffer length Register (Default Value: 0x01400280) .....	421
6.1.4.20.	CSI Channel_0 flip size Register (Default Value: 0x01E00280).....	421
6.1.4.21.	CSI Channel_0 frame clock counter Register (Default Value: 0x00000000) .....	421
6.1.4.22.	CSI Channel_0 accumulated and internal clock counter Register (Default Value: 0x00000000) 422	
6.1.4.23.	CSI Channel_0 FIFO Statistic Register (Default Value: 0x00000000).....	422
6.1.4.24.	CSI Channel_0 PCLK Statistic Register (Default Value: 0x00007FFF) .....	422
6.1.4.25.	CCI Control Register (Default Value: 0x00000000) .....	423
6.1.4.26.	CCI Transmission Configuration Register (Default Value: 0x10000000) .....	424
6.1.4.27.	CCI Packet Format Register (Default Value: 0x00110001) .....	425
6.1.4.28.	CCI Bus Control Register (Default Value: 0x00002500).....	425
6.1.4.29.	CCI Interrupt Control Register (Default Value: 0x00000000).....	426

6.1.4.30.	CCI Line Counter Trigger Control Register (Default Value: 0x00000000).....	426
6.1.4.31.	CCI FIFO Access Register (Default Value: 0x00000000) .....	426
Chapter 7	Display.....	427
7.1.	DE2.0.....	428
7.1.1.	Overview .....	428
7.2.	TCON .....	429
7.2.1.	Overview .....	429
7.2.2.	Block Diagram .....	429
7.2.3.	Functionalities Description.....	429
7.2.3.1.	RGB gamma correction .....	429
7.2.3.2.	CEU module.....	430
7.2.4.	LCD0 Module Register List .....	430
7.2.5.	LCD0 Module Register Description .....	431
7.2.5.1.	TCON Global Control Register (Default Value: 0x00000000) .....	431
7.2.5.2.	TCON Global Interrupt Register0 (Default Value: 0x00000000).....	431
7.2.5.3.	TCON Global Interrupt Register1 (Default Value: 0x00000000).....	432
7.2.5.4.	TCON1 Control Register (Default Value: 0x00000000) .....	432
7.2.5.5.	TCON1 Basic Timing Register0 (Default Value: 0x00000000) .....	432
7.2.5.6.	TCON1 Basic Timing Register1 (Default Value: 0x00000000) .....	433
7.2.5.7.	TCON1 Basic Timing Register2 (Default Value: 0x00000000) .....	433
7.2.5.8.	TCON1 Basic Timing Register3 (Default Value: 0x00000000) .....	433
7.2.5.9.	TCON1 Basic Timing Register4 (Default Value: 0x00000000) .....	434
7.2.5.10.	TCON1 Basic Timing Register5 (Default Value: 0x00000000) .....	434
7.2.5.11.	TCON CEU Control Register (Default Value: 0x00000000).....	434

7.2.5.12.	TCON CEU Coefficient Mul Register (Default Value: 0x00000000) .....	434
7.2.5.13.	TCON CEU Coefficient Add Register (Default Value: 0x00000000) .....	435
7.2.5.14.	TCON CEU Coefficient Range Register (Default Value: 0x00000000).....	435
7.2.5.15.	TCON1 Fill Control Register (Default Value: 0x00000000).....	436
7.2.5.16.	TCON1 Fill Begin Register (Default Value: 0x00000000).....	436
7.2.5.17.	TCON1 Fill End Register (Default Value: 0x00000000).....	436
7.2.5.18.	TCON1 Fill Data Register (Default Value: 0x00000000) .....	436
7.2.6.	LCD1 Module Register List .....	436
7.2.7.	LCD1 Module Register Description .....	437
7.2.7.1.	TCON Global Control Register (Default Value: 0x00000000) .....	437
7.2.7.2.	TCON Global Interrupt Register0 (Default Value: 0x00000000).....	438
7.2.7.3.	TCON Global Interrupt Register1 (Default Value: 0x00000000).....	438
7.2.7.4.	TCON1 Control Register (Default Value: 0x00000000) .....	438
7.2.7.5.	TCON1 Basic Timing Register0 (Default Value: 0x00000000) .....	439
7.2.7.6.	TCON1 Basic Timing Register1 (Default Value: 0x00000000) .....	439
7.2.7.7.	TCON1 Basic Timing Register2 (Default Value: 0x00000000) .....	439
7.2.7.8.	TCON1 Basic Timing Register3 (Default Value: 0x00000000) .....	440
7.2.7.9.	TCON1 Basic Timing Register (Default Value: 0x00000000) .....	440
7.2.7.10.	TCON1 Basic Timing Register5 (Default Value: 0x00000000) .....	440
7.2.7.11.	TCON CEU Control Register (Default Value: 0x00000000) .....	441
7.2.7.12.	TCON CEU Coefficient Mul Register (Default Value: 0x00000000) .....	441
7.2.7.13.	TCON CEU Coefficient Add Register (Default Value: 0x00000000) .....	441
7.2.7.14.	TCON CEU Coefficient Mul Register (Default Value: 0x00000000) .....	442
7.2.7.15.	TCON1 Fill Control Register (Default Value: 0x00000000).....	442

7.2.7.16.	TCON1 Fill Begin Register (Default Value: 0x00000000).....	442
7.2.7.17.	TCON1 Fill End Register (Default Value: 0x00000000).....	442
7.2.7.18.	TCON1 Fill Data Register (Default Value: 0x00000000) .....	443
Chapter 8	Interfaces.....	444
8.1.	TWI.....	445
8.1.1.	Overview .....	445
8.1.2.	Timing Diagram.....	445
8.1.3.	TWI Controller Special Requirement.....	446
8.1.3.1.	TWI Pin List.....	446
8.1.3.2.	TWI Controller Operation .....	446
8.1.4.	TWI Controller Register List.....	446
8.1.5.	TWI Controller Register Description.....	447
8.1.5.1.	TWI Slave Address Register(Default Value: 0x00000000).....	447
8.1.5.2.	TWI Extend Address Register(Default Value: 0x00000000).....	448
8.1.5.3.	TWI Data Register(Default Value: 0x00000000) .....	448
8.1.5.4.	TWI Control Register(Default Value: 0x00000000).....	448
8.1.5.5.	TWI Status Register(Default Value: 0x000000F8) .....	450
8.1.5.6.	TWI Clock Register(Default Value: 0x00000000) .....	451
8.1.5.7.	TWI Soft Reset Register(Default Value: 0x00000000).....	451
8.1.5.8.	TWI Enhance Feature Register(Default Value: 0x00000000).....	451
8.1.5.9.	TWI Line Control Register(Default Value: 0x0000_003A) .....	452
8.1.5.10.	TWI DVFS Register(Default Value: 0x00000000).....	452
8.2.	SPI.....	454
8.2.1.	Overview .....	454



8.2.2.	SPI Timing Diagram .....	454
8.2.3.	SPI Pin List .....	455
8.2.4.	SPI Register List .....	455
8.2.5.	SPI Register Description .....	456
8.2.5.1.	SPI Global Control Register(Default Value: 0x00000080) .....	456
8.2.5.2.	SPI Transfer Control Register(Default Value: 0x00000087).....	457
8.2.5.3.	SPI Interrupt Control Register(Default Value: 0x00000000) .....	459
8.2.5.4.	SPI Interrupt Status Register(Default Value: 0x00000022) .....	460
8.2.5.5.	SPI FIFO Control Register(Default Value: 0x00400001).....	462
8.2.5.6.	SPI FIFO Status Register(Default Value: 0x00000000) .....	463
8.2.5.7.	SPI Wait Clock Register(Default Value: 0x00000000).....	464
8.2.5.8.	SPI Clock Control Register(Default Value: 0x00000002) .....	464
8.2.5.9.	SPI Master Burst Counter Register(Default Value: 0x00000000) .....	465
8.2.5.10.	SPI Master Transmit Counter Register(Default Value: 0x00000000) .....	465
8.2.5.11.	SPI Master Burst Control Counter Register(Default Value: 0x00000000) .....	465
8.2.5.12.	SPI TX Data Register(Default Value: 0x00000000) .....	466
8.2.5.13.	SPI RX Data Register(Default Value: 0x00000000) .....	466
8.3.	UART.....	468
8.3.1.	Overview .....	468
8.3.2.	UART Timing Diagram .....	468
8.3.3.	UART Pin List .....	469
8.3.4.	UART Controller Register List .....	470
8.3.5.	UART Register Description.....	470
8.3.5.1.	UART Receiver Buffer Register(Default Value: 0x00000000) .....	470

8.3.5.2.	UART Transmit Holding Register(Default Value: 0x00000000) .....	471
8.3.5.3.	UART Divisor Latch Low Register(Default Value: 0x00000000).....	471
8.3.5.4.	UART Divisor Latch High Register(Default Value: 0x00000000).....	472
8.3.5.5.	UART Interrupt Enable Register(Default Value: 0x0000_0000) .....	472
8.3.5.6.	UART Interrupt Identity Register(Default Value: 0x00000000).....	473
8.3.5.7.	UART FIFO Control Register(Default Value: 0x00000000).....	474
8.3.5.8.	UART Line Control Register(Default Value: 0x00000000) .....	475
8.3.5.9.	UART Modem Control Register(Default Value: 0x00000000).....	477
8.3.5.10.	UART Line Status Register(Default Value: 0x00000060).....	478
8.3.5.11.	UART Modem Status Register(Default Value: 0x00000000).....	480
8.3.5.12.	UART Scratch Register(Default Value: 0x00000000) .....	481
8.3.5.13.	UART Status Register(Default Value: 0x00000006).....	482
8.3.5.14.	UART Transmit FIFO Level Register(Default Value: 0x00000000) .....	482
8.3.5.15.	UART Receive FIFO Level Register(Default Value: 0x00000000).....	483
8.3.5.16.	UART Halt TX Register(Default Value: 0x00000000) .....	483
8.4.	CIR Receiver.....	485
8.4.1.	Overview .....	485
8.4.2.	CIR Receiver Register List .....	485
8.4.3.	CIR Receiver Register Description .....	486
8.4.3.1.	CIR Receiver Control Register(Default Value: 0x00000000).....	486
8.4.3.2.	CIR Receiver Configure Register(Default Value: 0x00000004).....	486
8.4.3.3.	CIR Receiver FIFO Register(Default Value: 0x00000000) .....	486
8.4.3.4.	CIR Receiver Interrupt Control Register(Default Value: 0x00000000) .....	487
8.4.3.5.	CIR Receiver Status Register(Default Value: 0x00000000).....	487

8.4.3.6.	CIR Receiver Configure Register(Default Value: 0x00000000).....	488
8.5.	USB.....	490
8.5.1.	USB OTG Controller.....	490
8.5.1.1.	Overview.....	490
8.5.1.2.	Block Diagram.....	490
8.5.2.	USB Host Controller.....	491
8.5.2.1.	Overview.....	491
8.5.2.2.	Block Diagram.....	492
8.5.2.3.	USB Host Timing Diagram.....	492
8.5.2.4.	USB Host Register List.....	492
8.5.2.5.	EHCI Register Description.....	494
8.5.2.6.	OHCI Register Description.....	507
8.5.2.7.	HCI Interface Control and Status Register Description.....	524
8.5.2.8.	USB Host Clock Requirement.....	526
8.6.	I2S/PCM.....	527
8.6.1.	Overview.....	527
8.6.2.	Signal Description.....	527
8.6.2.1.	I2S/PCM Pin List.....	527
8.6.2.2.	Digital Audio Interface Clock Source and Frequency.....	527
8.6.3.	Functionalities Description.....	528
8.6.3.1.	Typical Applications.....	528
8.6.3.2.	Functional Block Diagram.....	528
8.6.4.	Timing Diagram.....	528
8.6.5.	Operation Modes.....	531

8.6.5.1.	System setup and I2S/PCM initialization.....	531
8.6.5.2.	The channel setup and DMA setup .....	531
8.6.5.3.	Enable and disable the I2S/PCM .....	531
8.6.6.	I2S/PCM Register List .....	532
8.6.7.	I2S/PCM Register Description .....	532
8.6.7.1.	I2S/PCM Control Register(Default Value: 0x00060000).....	532
8.6.7.2.	I2S/PCM Format Register0 (Default Value: 0x00000033) .....	534
8.6.7.3.	I2S/PCM Format Register1 (Default Value: 0x00000030) .....	535
8.6.7.4.	I2S/PCM Interrupt Status Register(Default Value: 0x00000010) .....	536
8.6.7.5.	I2S/PCM RX FIFO Register(Default Value: 0x00000000) .....	537
8.6.7.6.	I2S/PCM FIFO Control Register (Default Value: 0x000400F0).....	537
8.6.7.7.	I2S/PCM FIFO Status Register (Default Value: 0x10800000).....	538
8.6.7.8.	I2S/PCM DMA & Interrupt Control Register(Default Value: 0x00000000) .....	539
8.6.7.9.	I2S/PCM TX FIFO Register(Default Value: 0x00000000) .....	540
8.6.7.10.	I2S/PCM Clock Divide Register(Default Value: 0x00000000).....	540
8.6.7.11.	I2S/PCM TX Counter Register(Default Value: 0x00000000).....	541
8.6.7.12.	I2S/PCM RX Counter Register(Default Value: 0x00000000) .....	541
8.6.7.13.	I2S/PCM Channel Configuration Register(Default Value: 0x00000000) .....	541
8.6.7.14.	I2S/PCM TXn Channel Select Register(Default Value: 0x00000000).....	542
8.6.7.15.	I2S/PCM TXn Channel Mapping Register(Default Value: 0x00000000) .....	543
8.6.7.16.	I2S/PCM RX Channel Select Register(Default Value: 0x00000000).....	544
8.6.7.17.	I2S/PCM RX Channel Mapping Register(Default Value: 0x00000000).....	544
8.7.	OWA .....	546
8.7.1.	Overview .....	546

8.7.2.	Functional Description .....	546
8.7.2.1.	OWA Interface Pin List.....	546
8.7.2.2.	OWA Clock Requirement.....	546
8.7.2.3.	OWA Block Diagram .....	546
8.7.2.4.	OWA Frame Format.....	547
8.7.2.5.	Operation Modes .....	548
8.7.3.	OWA Register List .....	549
8.7.4.	OWA Register Description .....	549
8.7.4.1.	OWA General Control Register(Default Value : 0x00000080) .....	549
8.7.4.2.	OWA TX Configure Register(Default Value: 0x000000F0) .....	550
8.7.4.3.	OWA RX Configure Register(Default Value: 0x00000000) .....	551
8.7.4.4.	OWA Interrupt Status Register(Default Value: 0x00000010) .....	551
8.7.4.5.	OWA RX FIFO Register(Default Value: 0x00000000) .....	552
8.7.4.6.	OWA FIFO Control Register(Default Value: 0x00001078).....	553
8.7.4.7.	OWA FIFO Status Register(Default Value: 0x00006000) .....	554
8.7.4.8.	OWA Interrupt Control Register(Default Value: 0x00000000) .....	554
8.7.4.9.	OWA TX FIFO Register(Default Value: 0x00000000) .....	555
8.7.4.10.	OWA TX Counter Register(Default Value: 0x00000000).....	555
8.7.4.11.	OWA RX Counter Register(Default Value: 0x00000000) .....	556
8.7.4.12.	OWA TX Channel Status Register0(Default Value: 0x00000000).....	556
8.7.4.13.	OWA TX Channel Status Register1(Default Value: 0x00000000).....	557
8.7.4.14.	OWA RX Channel Status Register0(Default Value: 0x00000000) .....	558
8.7.4.15.	OWA RX Channel Status Register1(Default Value: 0x00000000) .....	560
8.8.	SCR .....	562

8.8.1.	Overview .....	562
8.8.2.	Block Diagram .....	562
8.8.3.	SCR Timing Diagram .....	563
8.8.4.	SCR Special Requirement .....	563
8.8.4.1.	Clock Generator .....	563
8.8.4.2.	SCIO Pad Configuration .....	564
8.8.5.	SCR Register List .....	564
8.8.6.	SCR Register Description .....	565
8.8.6.1.	Smart Card Reader Control and Status Register(Default Value: 0x00000000).....	565
8.8.6.2.	Smart Card Reader Interrupt Enable Register(Default Value: 0x00000000).....	566
8.8.6.3.	Smart Card Reader Interrupt Status Register(Default Value: 0x00000000).....	567
8.8.6.4.	Smart Card Reader FIFO Control and Status Register(Default Value: 0x00000000) .....	569
8.8.6.5.	Smart Card Reader FIFO Counter Register(Default Value: 0x00000000) .....	570
8.8.6.6.	Smart Card Reader Repeat Control Register(Default Value: 0x00000000) .....	570
8.8.6.7.	Smart Card Reader Clock Divisor Register(Default Value: 0x00000000) .....	570
8.8.6.8.	Smart Card Reader Line Time Register(Default Value: 0x00000000).....	571
8.8.6.9.	Smart Card Reader Character Time Register(Default Value: 0x00000000).....	571
8.8.6.10.	Smart Card Reader Line Control Register(Default Value: 0x00000000) .....	572
8.8.6.11.	Smart Card Reader FIFO Data Register(Default Value: 0x00000000).....	573
8.9.	EMAC.....	574
8.9.1.	Overview .....	574
8.9.2.	Block Diagram .....	574
8.9.3.	EMAC Core Register List .....	575
8.9.4.	EMAC Core Register Description .....	576

8.9.4.1.	Basic Control 0 Register(Default Value: 0x00000000) .....	576
8.9.4.2.	Basic Control 1 Register(Default Value: 0x08000000) .....	576
8.9.4.3.	Interrupt Status Register(Default Value: 0x00000000) .....	577
8.9.4.4.	Interrupt Enable Register(Default Value: 0x00000000) .....	578
8.9.4.5.	Transmit Control 0 Register(Default Value: 0x00000000) .....	579
8.9.4.6.	Transmit Control 1 Register(Default Value: 0x00000000) .....	579
8.9.4.7.	Transmit Flow Control Register(Default Value: 0x00000000) .....	580
8.9.4.8.	Transmit DMA Descriptor List Address Register(Default Value: 0x00000000) .....	581
8.9.4.9.	Receive Control 0 Register(Default Value: 0x00000000) .....	581
8.9.4.10.	Receive Control 1 Register(Default Value: 0x00000000) .....	581
8.9.4.11.	Receive DMA Descriptor List Address Register(Default Value: 0x00000000) .....	583
8.9.4.12.	Receive Frame Filter Register(Default Value: 0x00000000) .....	583
8.9.4.13.	Receive Hash Table 0 Register(Default Value: 0x00000000) .....	584
8.9.4.14.	Receive Hash Table 1 Register(Default Value: 0x00000000) .....	584
8.9.4.15.	MII Command Register(Default Value: 0x00000000) .....	585
8.9.4.16.	MII Data Register(Default Value: 0x00000000) .....	585
8.9.4.17.	MAC Address 0 High Register(Default Value: 0x0000FFFF) .....	585
8.9.4.18.	MAC Address 0 Low Register(Default Value: 0xFFFFFFFF) .....	586
8.9.4.19.	MAC Address x High Register(Default Value: 0x0000FFFF) .....	586
8.9.4.20.	MAC Address x Low Register(Default Value: 0xFFFFFFFF) .....	586
8.9.4.21.	Transmit DMA Status Register(Default Value: 0x00000000) .....	587
8.9.4.22.	Transmit DMA Current Descriptor Register(Default Value: 0x00000000) .....	587
8.9.4.23.	Transmit DMA Current Buffer Address Register(Default Value: 0x00000000) .....	587
8.9.4.24.	Receive DMA Status Register(Default Value: 0x00000000) .....	587

8.9.4.25.	Receive DMA Current Descriptor Register(Default Value: 0x00000000) .....	588
8.9.4.26.	Receive DMA Current Buffer Address Register(Default Value: 0x00000000) .....	588
8.9.4.27.	RGMII Status Register(Default Value: 0x00000000).....	588
8.9.5.	EMAC RX/TX Descriptor.....	588
8.9.5.1.	Transmit Descriptor .....	589
8.9.5.2.	Receive Descriptor .....	590
8.10.	TSC.....	593
8.10.1.	Overview .....	593
8.10.2.	Transport Stream Input Timing Diagram.....	594
8.10.3.	Transport Stream Controller Register List .....	596
8.10.4.	Transport Stream Controller Register Description .....	597
8.10.4.1.	TSC Control Register(Default Value: 0x00000000) .....	597
8.10.4.2.	TSC Status Register(Default Value: 0x00000000) .....	597
8.10.4.3.	TSC Port Control Register(Default Value: 0x00000000).....	597
8.10.4.4.	TSC Port Parameter Register(Default Value: 0x00000000).....	597
8.10.4.5.	TSC TSF Input Multiplex Control Register(Default Value: 0x00000000) .....	598
8.10.4.6.	TSC Port Output Multiplex Control Register(Default Value: 0x00000000) .....	598
8.10.4.7.	TSC Port Output Multiplex Control Register(Default Value: 0x00000000) .....	598
8.10.4.8.	TSG Packet Parameter Register(Default Value: 0x00470000).....	599
8.10.4.9.	TSG Interrupt Enable and Status Register(Default Value: 0x00000000).....	600
8.10.4.10.	TSG Clock Control Register(Default Value: 0x00000000) .....	601
8.10.4.11.	TSG Buffer Base Address Register(Default Value: 0x00000000) .....	601
8.10.4.12.	TSG Buffer Size Register(Default Value: 0x00000000) .....	601
8.10.4.13.	TSG Buffer Point Register(Default Value: 0x00000000).....	602



8.10.4.14.	TSF Control and Status Register(Default Value: 0x00000000).....	602
8.10.4.15.	TSF Packet Parameter Register(Default Value: 0x00470000) .....	602
8.10.4.16.	TSF Interrupt Enable and Status Register(Default Value: 0x00000000) .....	603
8.10.4.17.	TSF DMA Interrupt Enable Register(Default Value: 0x00000000) .....	604
8.10.4.18.	TSF Overlap Interrupt Enable Register(Default Value: 0x00000000).....	604
8.10.4.19.	TSF DMA Interrupt Status Register(Default Value: 0x00000000) .....	604
8.10.4.20.	TSF Overlap Interrupt Status Register(Default Value: 0x00000000).....	604
8.10.4.21.	TSF PCR Control Register(Default Value: 0x00000000) .....	605
8.10.4.22.	TSF PCR Data Register(Default Value: 0x00000000).....	605
8.10.4.23.	TSF Channel Enable Register(Default Value: 0x00000000).....	605
8.10.4.24.	TSF PES Enable Register(Default Value: 0x00000000) .....	606
8.10.4.25.	TSF Channel Descramble Enable Register(Default Value: 0x00000000).....	606
8.10.4.26.	TSF Channel Index Register(Default Value: 0x00000000).....	606
8.10.4.27.	TSF Channel Control Register(Default Value: 0x00000000).....	606
8.10.4.28.	TSF Channel Status Register(Default Value: 0x00000000) .....	607
8.10.4.29.	TSF Channel CW Index Register(Default Value: 0x00000000) .....	607
8.10.4.30.	TSF Channel PID Register(Default Value: 0x1FFF0000) .....	607
8.10.4.31.	TSF Channel Buffer Base Address Register(Default Value: 0x00000000) .....	607
8.10.4.32.	TSF Channel Buffer Size Register(Default Value: 0x00000000) .....	608
8.10.4.33.	TSF Channel Write Pointer Register(Default Value: 0x00000000).....	608
8.10.4.34.	TSF Channel Read Pointer Register(Default Value: 0x00000000).....	608
8.10.4.35.	TSD Control Register(Default Value: 0x00000000) .....	609
8.10.4.36.	TSD Status Register(Default Value: 0x00000000) .....	609
8.10.4.37.	TSD Control Word Index Register(Default Value: 0x00000000) .....	609

8.10.4.38.	TSD Control Word Register(Default Value: 0x00000000) .....	609
Chapter 9	Electrical Characteristics .....	611
9.1.	Absolute Maximum Ratings .....	611
9.2.	Recommended Operating Conditions .....	612
9.3.	DC Electrical Characteristics .....	613
9.4.	Oscillator Electrical Characteristics .....	614
9.5.	Power on and Power off Sequence .....	615
Appendix	.....	617
Pin Map	.....	617
Package Dimension	.....	618

Confidential

# Chapter 1 About This Documentation

## 1.1. Documentation Overview

This documentation provides an overall description of the Allwinner quad-core H3 application processor, which will provide instructions to programmers from several sections, including system, memory, image, display and interface.

## 1.2. Acronyms and abbreviations

The table below contains acronyms and abbreviations used in this document.

A		
AES	Advanced Encryption Standard	A specification for the encryption of electronic data established by the U.S. National Institute of Standards and Technology (NIST) in 2001
AGC	Automatic Gain Control	An adaptive system found in electronic devices that automatically controls the gain of a signal: the average output signal level is fed back to adjust the gain to an appropriate level for a range of input signal levels
AHB	AMBA High-speed Bus	A bus protocol introduced in Advanced Microcontroller Bus Architecture version 2 published by ARM Ltd company
APB	Advanced Peripheral Bus	APB is designed for low bandwidth control accesses, which has an address and data phase similar to AHB, but a much reduced, low complexity signal list (for example no bursts)
AVS	Audio Video Standard	A compression standard for digital audio and video
C		
CIR	Consumer IR	The CIR (Consumer IR) interface is used for remote control through infra-red light
CRC	Cyclic Redundancy Check	A type of hash function used to produce a checksum in order to detect errors in data storage or transmission

CSI	CMOS Sensor Interface	The hardware block that interfaces with different image sensor interfaces and provides a standard output that can be used for subsequent image processing
D		
DES	Data Encryption Standard	A previously predominant algorithm for the encryption of electronic data
DLL	Delay-Locked Loop	A digital circuit similar to a phase-locked loop (PLL), with the main difference being the absence of an internal voltage-controlled oscillator, replaced by a delay line
DRC	Dynamic Range Compression	It reduces the volume of loud sounds or amplifies quiet sounds by narrowing or "compressing" an audio signal's dynamic range.
DVFS	Dynamic Voltage and Frequency Scaling	Dynamic voltage scaling is a power management technique where the voltage used in a component is increased or decreased, depending on circumstances. Dynamic frequency scaling is a technique whereby the frequency of a microprocessor can be automatically adjusted on the fly so that the power consumption or heat generated by the chip can be reduced. These two are often used together to save power in mobile devices.
E		
EHCI	Enhanced Host Controller Interface	The register-level interface for a Host Controller for the USB Revision 2.0.
eMMC	Embedded Multi-Media Card	An architecture consisting of an embedded storage solution with MMC interface, flash memory and controller, all in a small BGA package.
F		
FBGA	Fine Ball Grid Array	FBGA is based on BGA technology, but comes with thinner contacts and is mainly used in SoC design
G		
GIC	Generic Interrupt Controller	A centralized resource for supporting and managing interrupts in a system that includes at least one processor
H		

HDMI	High-Definition Multimedia Interface	A compact audio/video interface for transmitting uncompressed digital data
I		
I2S	Inter IC Sound	An electrical serial bus interface standard used for connecting digital audio devices together
L		
LSB	Least Significant Bit	The bit position in a binary integer giving the units value, that is, determining whether the number is even or odd. It is sometimes referred to as the right-most bit, due to the convention in positional notation of writing less significant digits further to the right.
K		
KEYADC	Analog to Digital Converter	Used for KEY Application
M		
MAC	Media Access Control	A sublayer of the data link layer, which provides addressing and channel access control mechanisms that make it possible for several terminals or network nodes to communicate within a multiple access network that incorporates a shared medium, e.g. Ethernet.
MII	Media Independent Interface	An interface originally designed to connect a fast Ethernet MAC-block to a PHY chip, which now has been extended to support reduced signals and increased speeds.
MIPI	Mobile Industry Processor Interface	MIPI alliance is an open membership organization that includes leading companies in the mobile industry that share the objective of defining and promoting open specifications for interfaces inside mobile terminals.
MIPI DSI	MIPI Display Serial Interface	A specification by the Mobile Industry Processor Interface (MIPI) Alliance aimed at reducing the cost of display sub-systems in a mobile device
MSB	Most Significant Bit	The bit position in a binary number having the greatest value, which is sometimes referred to as the left-most bit due to the convention in positional notation of writing more significant digits further to the left
N		

NTSC	National Television System Committee	An analog television system that is used in most of North America, and many other countries
O		
OHCI	Open Host Controller Interface	A register-level interface that enables a host controller for USB to communicate with a host controller driver in software
P		
PAL	Phase Alternating Line	An analogue television color encoding system used in broadcast television systems in many countries
PCM	Pulse Code Modulation	A method used to digitally represent sampled analog signals
PID	Packet Identifier	Each table or elementary stream in a transport stream is identified by a 13-bit packet ID (PID).A demultiplexer extracts elementary streams from the transport stream in part by looking for packets identified by the same PID.
S		
SPI	Synchronous Peripheral Interface	A synchronous serial data link standard that operates in full duplex mode. Devices communicate in master/slave mode where the master device initiates the data frame.
U		
USB OTG	Universal Serial Bus On The Go	A Dual Role Device controller, which supports both USB Host and USB Device functions.
UART	Universal Asynchronous Receiver/Transmitter	A serial communication interface,which translates data between parallel and serial forms.UARTs are commonly used in conjunction with communication standards.

## Chapter 2 Overview

The Allwinner H3 is a highly cost-efficient quad-core OTT Box processor, which is a part of growing home entertainment products that offers high-performance processing with a high degree of functional integration.

The H3 processor has some very exciting features, for example:

- CPU architecture: Quad-core Cortex™-A7 with separately NEON coprocessor, the most power efficient CPU core ARM's ever developed.
- Graphics: ARM Mali400MP2 graphics acceleration provides mobile users with superior experience in web browsing, video playback and gaming effects; OpenGL ES2.0 ,OpenVG1.1 standards are supported.
- Video Engine: H3 provides almost full motion playback of up to 1080P high-definition video, and supports H.265 decoder by 4K@30fps , H.264 decoder by 1080p@60fps, MPEG1/2/4 decoder by 1080p@60fps, VP8/AVS jizhun decoder by 1080p@60fps, VC1decoder by 1080p@30fps, H.264 encoder by 1080p@30fps with dedicated hardware.
- Display Subsystem: Supports DE2.0 for excellent display experience, and two display interfaces for HDMI1.4 and CVBS display.
- Memory Controller: The processor supports many types of external memory devices, including LPDDR2, LPDDR3, DDR2, DDR3 ,DDR3L, NAND Flash(MLC,SLC,TLC,EF),Nor Flash, SD/SDIO/MMC including eMMC up to rev4.41.
- Security System: The processor delivers hardware security features that enable trustzone security system, Digital Rights Management(DRM) , information encryption/decryption, secure boot, secure JTAG and secure efuse.
- Interfaces: The processor has a broad range of hardware interfaces such as parallel CMOS sensor interface, 10/100/1000Mbps EMAC with FE PHY, USB Dual-Role Device v2.0 operating at high speed(480Mbps) with PHY, USB Host with PHY and a variety of other popular interfaces(SPI,UART,CIR,TS,TWI,SCR).

## 2.1. Processor Features

### 2.1.1. CPU Architecture

- Quad-core ARM Cortex™-A7 MPCore™ Processor
- Thumb-2 Technology
- Support NEON Advanced SIMD(Single Instruction Multiple Data)instruction for acceleration of media and signal processing functions
- Support Large Physical Address Extensions(LPAE)
- VFPv4 Floating Point Unit
- 32KB L1 Instruction cache and 32KB L1 Data cache per core
- 512KB L2-cache

### 2.1.2. GPU Architecture

- ARM Mali400MP2 GPU
- Support OpenGL ES 2.0 and OpenVG 1.1 standard

### 2.1.3. Memory Subsystem

#### 2.1.3.1. Boot ROM

- On chip ROM
- Size:96KB
- Support secure and non-secure access boot
- Support system boot from the following devices:
  - NAND Flash
  - SD/TF card
  - eMMC
  - Nor Flash
- Support system code download through USB OTG

#### 2.1.3.2. SDRAM

- Compatible with JEDEC standard DDR2 /DDR3 /DDR3L/LPDDR2/LPDDR3 SDRAM
- Up to 2GB address space
- Support 2 chip select



- 16 address signal lines and 3 bank signal lines
- 32-bits bus width
- Support clock frequency up to 667 MHz(DDR3-1333)
- Runtime-configurable parameters setting for application flexibility
- Random read or write operation is supported

#### 2.1.3.3. NAND Flash

- Up to 2 flash chips
- 8-bit data bus width
- Up to 64-bit ECC per 1024 bytes
- Support 1024, 2048, 4096, 8192, 16K bytes size per page
- Support SLC/MLC/TLC flash and EF-NAND memory
- Support SDR, ONFI DDR and Toggle DDR NAND
- Embedded DMA to do data transfer
- Support data transfer together with normal DMA

#### 2.1.3.4. SD/MMC

- Up to three SD/MMC controller interfaces
- Comply to eMMC standard specification V4.41, SD physical layer specification V2.0, SDIO card specification V3.0
- 1-bit or 4-bit data bus transfer mode for SD and SDIO cards up to 50MHz
- 1-bit ,4-bit or 8-bit data bus transfer mode for MMC cards up to 50MHz in both SDR and DDR modes(100MB/s)
- Embedded special DMA to do data transfer
- Support SDIO suspend and resume operation
- Support hardware CRC generation and error detection
- Support SDIO interrupt detection

### 2.1.4. System Peripheral

#### 2.1.4.1. Timer

- Two on-chip timers with interrupt-based operation
- One watchdogs to generate reset signal or interrupts
- 33-bit Audio/Video Sync(AVS) Counter to synchronize video and audio in the player
- Input from Internal OSC and OSC24M

#### 2.1.4.2. High Speed Timer

- Counters up to 56 bits
- Clock source is synchronized with AHB clock, much more accurate than other timers

#### 2.1.4.3. RTC

- Time,calendar
- Counters second,minutes,hours,day,week,month and year with leap year generator
- Alarm:general alarm and weekly alarm
- One 32KHz fanout

#### 2.1.4.4. GIC

- Support 16 Software Generated Interrupts(SGIs), 16 Private Peripheral Interrupts(PPIs) and 125 Shared Peripheral Interrupts(SPIs)

#### 2.1.4.5. DMA

- Up to 12-channels DMA
- Interrupt generated for each DMA channel
- Flexible data width of 8/16/32/64-bits
- Support linear and IO address modes
- Support data transfer types with memory-to-memory, memory-to-peripheral, peripheral-to-memory

#### 2.1.4.6. CCU

- 9 PLLs
- Support a external 24MHz oscillator and an on-chip RC oscillator
- Support clock configuration and clock generated for corresponding modules
- Support software-controlled clock gating and software-controlled reset for corresponding modules

#### 2.1.4.7. PWM

- Up to two PWM channels
- Support outputting two kinds of waveform: continuous waveform and pulse waveform
- 0% to 100% adjustable duty cycle
- Up to 24MHz output frequency

#### 2.1.4.8. Crypto Engine(CE)

- Support symmetrical algorithm: AES, DES, TDES
- Support asymmetrical algorithm:RSA512/1024/2048/3072/4096-bits,ECC160/224/256/521-bits
- Support hash algorithm:SHA-1/SHA-224/SHA-256,SHA384,SHA512,MD5,HMAC-SHA1
- Support 160-bits hardware PRNG with 175-bits seed
- Support 256-bits TRNG
- Support ECB,CBC, CTR, CTS,OFB,CFB,CBC-MAC modes for AES
- Support ECB, CBC, CTR,CBC-MAC modes for DES
- Support ECB, CBC, CTR modes for TDES
- 128-bits, 192-bits and 256-bits key size for AES
- Embedded special DMA to do data transfer

#### 2.1.4.9. Security ID

- Support 2K-bits EFUSE for chip ID and security application

#### 2.1.4.10. CPU Configuration

- Support power clamp
- Flexible CPU configuration

#### 2.1.4.11. Power Management

- Support DVFS for CPU frequency and voltage adjustment
- Flexible clock gate and module reset
- Dynamic frequency adjustment for external DRAM
- Multiple power domains

### 2.1.5. Display Subsystem

#### 2.1.5.1. DE2.0

- Output size up to 4096x4096
- Support four alpha blending channel for main display, two channel for aux display
- Support four overlay layers in each channel, and has a independent scaler
- Support potter-duff compatible blending operation

- Support input format YUV422/YUV420/YUV411/ARGB8888/XRGB8888/RGB888/ARGB4444/ARGB1555 and RGB565
- Support Frame Packing/Top-and-Bottom/Side-by-side Full/Side-by-Side Half 3D format data
- Support SmartColor 2.0 for excellent display experience
  - Adaptive edge sharpening
  - Adaptive color enhancement
  - Adaptive contrast enhancement and fresh tone rectify
- Support writeback for high efficient dual display

#### 2.1.5.2. Display Output

- Total two display interfaces available
- Two interfaces may be active in parallel
  - HDMI V1.4 output with HDCP1.2, up to 4K@30fps
  - TV CVBS output
- Support dynamic adjustment output resolution
- Support HDMI 3D function
- Support Hardware CEC

#### 2.1.6. Video Engine

##### 2.1.6.1. Video Decoding

- Support multi-format video playback, including:
  - H.265:1080p@60fps,4K@30fps
  - H.264:1080p@60fps
  - MPEG1/2/4:1080p@60fps
  - VP8:1080p@60fps
  - VC1:1080p@30fps
  - AVS jizhun: 1080p@60fps
  - MJPEG:1080p@30fps
- Support 3D size:3840x1080,1920x2160

##### 2.1.6.2. Video Encoding

- Support H.264 video encoding up to 1080p@30fps
- Support input picture size up to 4800x4800
- Support input format: tiled (128x32)/YU12/YV12/NU12/NV12/ARGB/YUYV
- Support Alpha blending
- Support thumb generation

- Support 4x2 scaling ratio: from 1/16 to 64 arbitrary non-integer ratio
- Support rotated input

## 2.1.7. Image Subsystem

### 2.1.7.1. CSI

- Support 8-bits YUV422 CMOS sensor interface
- Support CCIR656 protocol for NTSC and PAL
- Support up to 5M pixel camera sensor
- Support video capture resolution up to 1080p@30fps

## 2.1.8. Audio Subsystem

### 2.1.8.1. Audio Codec

- Two audio digital-to-analog(DAC) channels
- Support analog/ digital volume control
- One low-noise analog microphone bias output
- Analog low-power loop from line-in /microphone to lineout outputs
- Support Dynamic Range Controller adjusting the DAC playback output
- Three audio inputs:
  - Two differential microphone inputs
  - Stereo Linein input
- Two audio analog-to-digital(ADC) channels
  - 92dB SNR@A-weight
  - Supports ADC Sample Rates from 8KHz to 48KHz
- Support Automatic Gain Control(AGC) and Dynamic Range Control(DRC) adjusting the ADC recording input

### 2.1.8.2. One Wire Audio(OWA)

- IEC-60958 transmitter and receiver functionality
- Complies with SPDIF Interface
- Support channel status insertion for the transmitter
- Hardware Parity generation on the transmitter
- One 32x24bits FIFO (TX) for audio data transfer
- Programmable FIFO thresholds

### 2.1.8.3. I2S/PCM

- Compliant with standard Inter-IC sound(I2S) bus specification
- Compliant with left-justified, right-justified, PCM mode, and TDM(Time Division Multiplexing) format
- Full-duplex synchronous work mode
- Master and slave mode configured
- Adjustable audio sample resolution from 8-bit to 32-bit
- Sample rate from 8KHz to 192KHz

## 2.1.9. External Peripherals

### 2.1.9.1. USB

- One USB 2.0 OTG,with integrated USB PHY
  - Complies with USB2.0 Specification
  - Support High-Speed (HS,480Mbps),Full-Speed(FS,12Mbps) and Low-Speed(LS,1.5Mbps) in host mode
  - Complies with Enhanced Host Controller Interface(EHCI)Specification, Version 1.0, and the Open Host Controller Interface(OHCI) Specification, Version 1.0a for host mode
  - Up to 8 User-Configurable Endpoints in device mode
  - Support point-to-point and point-to-multipoint transfer in both host and peripheral mode
- Three USB Host, with integrated three USB PHY
  - Complies with Enhanced Host Controller Interface(EHCI)Specification, Version 1.0, and the Open Host Controller Interface(OHCI) Specification, Version 1.0a.

### 2.1.9.2. Ethernet

- Integrated an internal 10/100M PHY
- Support 10/100/1000Mbps data transfer rate
- Support MII/RGMII/RMII interface
- Support full-duplex and half-duplex operation
- Programmable frame length
- Automatic CRC and pad generation controllable on a per-frame basis
- Options for Automatic Pad/CRC Stripping on receive frames
- Programmable frame length to support Standard or Jumbo Ethernet frames with sizes up to 16 KB
- Programmable Inter Frame Gap (40-96 bit times in steps of 8)
- Supports a variety of flexible address filtering modes

### 2.1.9.3. ADC

- KEYADC with 6-bit resolution

- Support hold key and continuous key
- Support single key, normal key and continuous key

#### 2.1.9.4. CIR

- A flexible receiver for IR remote
- Programmable FIFO threshold

#### 2.1.9.5. UART

- Up to five UART controllers
- 64-Bytes Transmit and receive data FIFOs for all UART
- Compatible with industry-standard 16550 UARTs
- Support Infrared Data Association(IrDA) 1.0 SIR

#### 2.1.9.6. SPI

- Up to two SPI controllers
- Full-duplex synchronous serial interface
- Master/Slave configurable
- Mode0~3 are supported for both transmit and receive operations
- Two 64-Bytes FIFO for SPI-TX and SPI-RX operation
- DMA-based or interrupt-based operation
- Polarity and phase of the chip select(SPI\_SS) and SPI\_Clock(SPI\_SCLK) are configurable
- Support single and dual read mode

#### 2.1.9.7. TWI

- Up to four TWI(Two Wire Interface) controllers
- Support Standard mode(up to 100K bps) and Fast mode(up to 400K bps)
- Master/Slave configurable
- Allows 10-bit addressing transactions

#### 2.1.9.8. TS

- Compliant with the industry-standard AMBA Host Bus(AHB) Specification, Revision 2.0.Support 32-bit Little Endian bus.
- Support DVB-CSA V1.1 Descrambler
- One external Synchronous Parallel Interface(SPI) or one external Synchronous Serial Interface(SSl)

- Configurable SPI and SSI timing parameters
- Hardware packet synchronous byte error detecting
- Hardware PCR packet detecting

#### 2.1.9.9. SCR

- Supports APB slave interface for easy integration with AMBA-based host systems
- Supports the ISO/IEC 7816-3:1997(E) and EMV2000 (4.0) Specifications
- Supports adjustable clock rate and bit rate
- Configurable automatic byte repetition
- Support asynchronous half-duplex character transmission and block transmission
- Supports synchronous and any other non-ISO 7816 and non-EMV cards
- Performs functions needed for complete smart card sessions, including:
  - Card activation and deactivation
  - Cold/warm reset
  - Answer to Reset (ATR) response reception
  - Data transfers to and from the card

#### 2.1.10. Package

- FBGA 347 balls, 0.65mm ball pitch, 14mm x 14mm

Confidential



## 2.2. System Block Diagram

The following figure shows the block diagram of H3 processor.

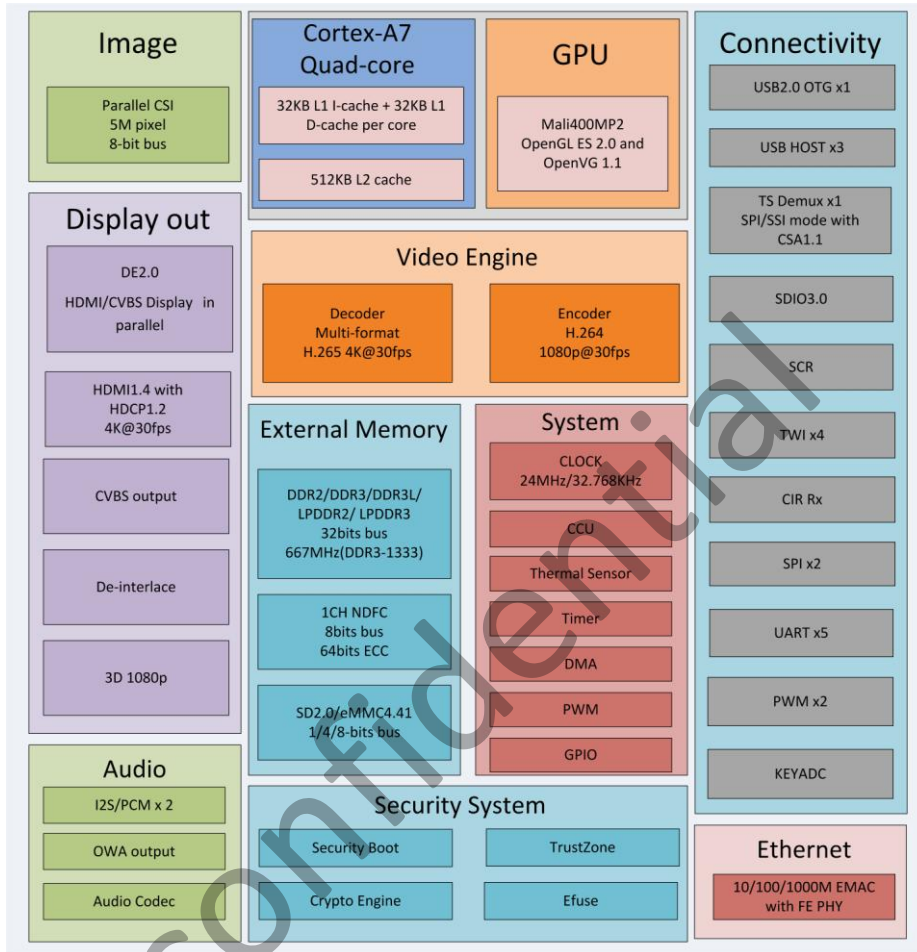

Figure 2-1. H3 Block Diagram

# Chapter 3 Pin Description

## 3.1. Pin Characteristics

Table 3-1 lists the characteristics of H3 Pins from seven aspects: BALL#, Pin Name, Default Function, Type, Reset State, Default Pull Up/Down, and Buffer Strength.

Table 3-1. Pin Characteristics

Ball#	Pin Name	Default Function	Type	Reset State	Default Pull Up/Down	Buffer Strength (mA)
<b>DRAM</b>						
T17	SA0	DRAM	I/O	Z	-	-
U18	SA1	DRAM	I/O	Z	-	-
V19	SA2	DRAM	I/O	Z	-	-
V20	SA3	DRAM	I/O	Z	-	-
V21	SA4	DRAM	I/O	Z	-	-
Y19	SA5	DRAM	I/O	Z	-	-
Y20	SA6	DRAM	I/O	Z	-	-
V15	SA7	DRAM	I/O	Z	-	-
W18	SA8	DRAM	I/O	Z	-	-
Y18	SA9	DRAM	I/O	Z	-	-
P19	SA10	DRAM	I/O	Z	-	-
N19	SA11	DRAM	I/O	Z	-	-
R18	SA12	DRAM	I/O	Z	-	-
V12	SA13	DRAM	I/O	Z	-	-
N17	SA14	DRAM	I/O	Z	-	-
R17	SA15	DRAM	I/O	Z	-	-
W17	SBA0	DRAM	O	Z	-	-
T18	SBA1	DRAM	O	Z	-	-
V17	SBA2	DRAM	O	Z	-	-
U15	SCAS	DRAM	O	Z	-	-
AA19	SCK	DRAM	O	Z	-	-
AA20	SCKB	DRAM	O	Z	-	-
AA21	SCKE0	DRAM	O	Z	-	-
Y21	SCKE1	DRAM	O	Z	-	-
W20	SCS0	DRAM	O	Z	-	-
W21	SCS1	DRAM	O	Z	-	-
N20	SDQ0	DRAM	I/O	Z	-	-
P21	SDQ1	DRAM	I/O	Z	-	-
P20	SDQ2	DRAM	I/O	Z	-	-

Ball#	Pin Name	Default Function	Type	Reset State	Default Pull Up/Down	Buffer Strength (mA)
U21	SDQ3	DRAM	I/O	Z	-	-
R19	SDQ4	DRAM	I/O	Z	-	-
T20	SDQ5	DRAM	I/O	Z	-	-
U19	SDQ6	DRAM	I/O	Z	-	-
U20	SDQ7	DRAM	I/O	Z	-	-
J19	SDQ8	DRAM	I/O	Z	-	-
H20	SDQ9	DRAM	I/O	Z	-	-
H21	SDQ10	DRAM	I/O	Z	-	-
J21	SDQ11	DRAM	I/O	Z	-	-
L20	SDQ12	DRAM	I/O	Z	-	-
L21	SDQ13	DRAM	I/O	Z	-	-
M21	SDQ14	DRAM	I/O	Z	-	-
M19	SDQ15	DRAM	I/O	Z	-	-
Y17	SDQ16	DRAM	I/O	Z	-	-
AA17	SDQ17	DRAM	I/O	Z	-	-
Y16	SDQ18	DRAM	I/O	Z	-	-
W15	SDQ19	DRAM	I/O	Z	-	-
Y14	SDQ20	DRAM	I/O	Z	-	-
AA14	SDQ21	DRAM	I/O	Z	-	-
Y13	SDQ22	DRAM	I/O	Z	-	-
Y12	SDQ23	DRAM	I/O	Z	-	-
W12	SDQ24	DRAM	I/O	Z	-	-
AA11	SDQ25	DRAM	I/O	Z	-	-
Y11	SDQ26	DRAM	I/O	Z	-	-
Y10	SDQ27	DRAM	I/O	Z	-	-
W9	SDQ28	DRAM	I/O	Z	-	-
AA8	SDQ29	DRAM	I/O	Z	-	-
Y8	SDQ30	DRAM	I/O	Z	-	-
Y7	SDQ31	DRAM	I/O	Z	-	-
M20	SDQM0	DRAM	O	Z	-	-
G20	SDQM1	DRAM	O	Z	-	-
AA18	SDQM2	DRAM	O	Z	-	-
AA12	SDQM3	DRAM	O	Z	-	-
R20	SDQS0	DRAM	I/O	Z	-	-
R21	SDQS0B	DRAM	I/O	Z	-	-
K20	SDQS1	DRAM	I/O	Z	-	-
J20	SDQS1B	DRAM	I/O	Z	-	-
AA15	SDQS2	DRAM	I/O	Z	-	-
Y15	SDQS2B	DRAM	I/O	Z	-	-
AA9	SDQS3	DRAM	I/O	Z	-	-
Y9	SDQS3B	DRAM	I/O	Z	-	-

Ball#	Pin Name	Default Function	Type	Reset State	Default Pull Up/Down	Buffer Strength (mA)
W11	SODT0	DRAM	O	Z	-	-
V11	SODT1	DRAM	O	Z	-	-
V13	SRAS	DRAM	O	Z	-	-
U16	SRST	DRAM	O	Z	-	-
T16	SVREF	DRAM	P	Z	-	-
W13	SWE	DRAM	O	Z	-	-
V10	SZQ	DRAM	A	Z	-	-
L16,M16,N16,P16, P17,R16,T12,T13,T 14,T15,U11	VCC-DRAM	POWER	P	-	-	-
<b>GPIO A</b>						
D11	PA0	GPIO	I/O	Z	NO PULL	20
D5	PA1	GPIO	I/O	Z	NO PULL	20
D6	PA2	GPIO	I/O	Z	NO PULL	20
E13	PA3	GPIO	I/O	Z	NO PULL	20
F5	PA4	GPIO	I/O	Z	NO PULL	20
H6	PA5	GPIO	I/O	Z	NO PULL	20
E14	PA6	GPIO	I/O	Z	NO PULL	20
D8	PA7	GPIO	I/O	Z	NO PULL	20
F13	PA8	GPIO	I/O	Z	NO PULL	20
D13	PA9	GPIO	I/O	Z	NO PULL	20
E11	PA10	GPIO	I/O	Z	NO PULL	20
F11	PA11	GPIO	I/O	Z	NO PULL	20
C13	PA12	GPIO	I/O	Z	NO_PULL	20
E15	PA13	GPIO	I/O	Z	NO_PULL	20
G12	PA14	GPIO	I/O	Z	NO_PULL	20
F14	PA15	GPIO	I/O	Z	NO_PULL	20
D15	PA16	GPIO	I/O	Z	NO_PULL	20
C14	PA17	GPIO	I/O	Z	NO_PULL	20
B13	PA18	GPIO	I/O	Z	NO_PULL	20
B14	PA19	GPIO	I/O	Z	NO_PULL	20
A13	PA20	GPIO	I/O	Z	NO_PULL	20
A14	PA21	GPIO	I/O	Z	NO_PULL	20
G13,G14,G15,H13, H14, J14	VCC_IO	POWER	P	-	-	-
<b>GPIO C</b>						
C15	PC0	GPIO	I/O	Z	NO PULL	20
C16	PC1	GPIO	I/O	Z	NO PULL	20
B16	PC2	GPIO	I/O	Z	NO PULL	20
B15	PC3	GPIO	I/O	Z	Pull-Up	20
F16	PC4	GPIO	I/O	Z	Pull-Up	20

Ball#	Pin Name	Default Function	Type	Reset State	Default Pull Up/Down	Buffer Strength (mA)
A17	PC5	GPIO	I/O	Z	NO PULL	20
E16	PC6	GPIO	I/O	Z	Pull-Up	20
A16	PC7	GPIO	I/O	Z	Pull-Up	20
B18	PC8	GPIO	I/O	Z	NO PULL	20
C17	PC9	GPIO	I/O	Z	NO PULL	20
D17	PC10	GPIO	I/O	Z	NO PULL	20
C18	PC11	GPIO	I/O	Z	NO PULL	20
B17	PC12	GPIO	I/O	Z	NO PULL	20
B19	PC13	GPIO	I/O	Z	NO PULL	20
F17	PC14	GPIO	I/O	Z	NO PULL	20
C19	PC15	GPIO	I/O	Z	NO PULL	20
H16	PC16	GPIO	I/O	Z	NO PULL	20
<b>GPIO D</b>						
C21	PD0	GPIO	I/O	Z	NO PULL	20
H17	PD1	GPIO	I/O	Z	NO PULL	20
B20	PD2	GPIO	I/O	Z	NO PULL	20
H18	PD3	GPIO	I/O	Z	NO PULL	20
A20	PD4	GPIO	I/O	Z	NO PULL	20
F19	PD5	GPIO	I/O	Z	NO PULL	20
B21	PD6	GPIO	I/O	Z	NO PULL	20
E18	PD7	GPIO	I/O	Z	NO PULL	20
E20	PD8	GPIO	I/O	Z	NO PULL	20
F21	PD9	GPIO	I/O	Z	NO PULL	20
H19	PD10	GPIO	I/O	Z	NO PULL	20
F20	PD11	GPIO	I/O	Z	NO PULL	20
E19	PD12	GPIO	I/O	Z	NO PULL	20
K17	PD13	GPIO	I/O	Z	NO PULL	20
L17	PD14	GPIO	I/O	Z	NO PULL	20
K18	PD15	GPIO	I/O	Z	NO PULL	20
L18	PD16	GPIO	I/O	Z	NO PULL	20
L19	PD17	GPIO	I/O	Z	NO PULL	20
J15	VCC_PD	POWER	P	-	-	-
<b>GPIO E</b>						
B10	PE0	GPIO	I/O	Z	NO PULL	20
A10	PE1	GPIO	I/O	Z	NO PULL	20
B11	PE2	GPIO	I/O	Z	NO PULL	20
C10	PE3	GPIO	I/O	Z	NO PULL	20
C9	PE4	GPIO	I/O	Z	NO PULL	20
E10	PE5	GPIO	I/O	Z	NO PULL	20
D10	PE6	GPIO	I/O	Z	NO PULL	20
C8	PE7	GPIO	I/O	Z	NO PULL	20

Ball#	Pin Name	Default Function	Type	Reset State	Default Pull Up/Down	Buffer Strength (mA)
C11	PE8	GPIO	I/O	Z	NO PULL	20
C12	PE9	GPIO	I/O	Z	NO PULL	20
E8	PE10	GPIO	I/O	Z	NO PULL	20
A11	PE11	GPIO	I/O	Z	NO PULL	20
B12	PE12	GPIO	I/O	Z	NO PULL	20
C7	PE13	GPIO	I/O	Z	NO PULL	20
C6	PE14	GPIO	I/O	Z	NO PULL	20
C5	PE15	GPIO	I/O	Z	NO PULL	20
<b>GPIO F</b>						
D19	PF0	GPIO	I/O	Z	NO PULL	20
A19	PF1	GPIO	I/O	Z	NO PULL	20
D20	PF2	GPIO	I/O	Z	NO PULL	20
F18	PF3	GPIO	I/O	Z	NO PULL	20
E21	PF4	GPIO	I/O	Z	NO PULL	20
C20	PF5	GPIO	I/O	Z	NO PULL	20
G18	PF6	GPIO	I/O	Z	NO PULL	20
<b>GPIO G</b>						
J3	PG0	GPIO	I/O	Z	NO PULL	20
L2	PG1	GPIO	I/O	Z	NO PULL	20
H4	PG2	GPIO	I/O	Z	NO PULL	20
F3	PG3	GPIO	I/O	Z	NO PULL	20
C2	PG4	GPIO	I/O	Z	NO PULL	20
C1	PG5	GPIO	I/O	Z	NO PULL	20
G4	PG6	GPIO	I/O	Z	NO PULL	20
D3	PG7	GPIO	I/O	Z	NO PULL	20
C3	PG8	GPIO	I/O	Z	NO PULL	20
E3	PG9	GPIO	I/O	Z	NO PULL	20
M3	PG10	GPIO	I/O	Z	NO PULL	20
D2	PG11	GPIO	I/O	Z	NO PULL	20
D1	PG12	GPIO	I/O	Z	NO PULL	20
B1	PG13	GPIO	I/O	Z	NO PULL	20
H7	VCC_PG	Power	P	-	-	-
<b>GPIO L</b>						
N1	PL0	GPIO	I/O	Z	Pull-Up	20
M1	PL1	GPIO	I/O	Z	Pull-Up	20
P2	PL2	GPIO	I/O	Z	NO PULL	20
R1	PL3	GPIO	I/O	Z	NO PULL	20
N2	PL4	GPIO	I/O	Z	NO PULL	20
R2	PL5	GPIO	I/O	Z	NO PULL	20
T4	PL6	GPIO	I/O	Z	NO PULL	20
T3	PL7	GPIO	I/O	Z	NO PULL	20

Ball#	Pin Name	Default Function	Type	Reset State	Default Pull Up/Down	Buffer Strength (mA)
T2	PL8	GPIO	I/O	Z	NO PULL	20
M6	PL9	GPIO	I/O	Z	NO PULL	20
V2	PL10	GPIO	I/O	Z	NO PULL	20
U2	PL11	GPIO	I/O	Z	NO PULL	20
<b>System Control</b>						
W6	UBOOT	-	I	-	Pull-Up	-
T5	TEST	-	I	-	Pull-Down	-
AA6	NMI	-	I	-	NO PULL	-
V6	RESET	-	I	-	NO PULL	-
L5	PLLTEST	-	A	-	-	-
P3	X32KFOUT	-	A	-	-	-
K2	X24MIN	-	A	-	-	-
K1	X24MOUT	-	A	-	-	-
K6	VCC_RTC	-	P	-	-	-
N3	VCC_PLL	-	P	-	-	-
<b>HDMI</b>						
G5	HCEC	-	A	-	-	-
M2	HHPD	-	A	-	-	-
H3	HSCL	-	A	-	-	-
K3	HSDA	-	A	-	-	-
F1	HTX0N	-	A	-	-	-
G1	HTX0P	-	A	-	-	-
G2	HTX1N	-	A	-	-	-
H2	HTX1P	-	A	-	-	-
J2	HTX2N	-	A	-	-	-
J1	HTX2P	-	A	-	-	-
E2	HTXCN	-	A	-	-	-
F2	HTXCP	-	A	-	-	-
J6	HVCC	-	P	-	-	-
M5	HGND	-	G	-	-	-
<b>USB</b>						
B5	USB_DM0	-	A	-	-	-
B7	USB_DM1	-	A	-	-	-
A8	USB_DM2	-	A	-	-	-
B9	USB_DM3	-	A	-	-	-
A5	USB_DP0	-	A	-	-	-
B6	USB_DP1	-	A	-	-	-
A7	USB_DP2	-	A	-	-	-
B8	USB_DP3	-	A	-	-	-
G11	VCC_USB	-	P	-	-	-
<b>AUDIO_CODEC</b>						

Ball#	Pin Name	Default Function	Type	Reset State	Default Pull Up/Down	Buffer Strength (mA)
U3	AGND	-	G	-	-	-
V3	AVCC	-	P	-	-	-
V1	LINEINL	-	A	-	-	-
W1	LINEINR	-	A	-	-	-
AA3	LINEOUTL	-	A	-	-	-
Y3	LINEOUTR	-	A	-	-	-
W3	MBIAS	-	A	-	-	-
Y1	MICIN1N	-	A	-	-	-
W2	MICIN1P	-	A	-	-	-
AA2	MICIN2N	-	A	-	-	-
Y2	MICIN2P	-	A	-	-	-
Y4	VRA1	-	A	-	-	-
W5	VRA2	-	A	-	-	-
V4	VRP	-	A	-	-	-
<b>EPHY</b>						
A2	EPHY_LINK_LED	-	A	-	-	-
F6	EPHY_RTX	-	A	-	-	-
A4	EPHY_RXN	-	A	-	-	-
B4	EPHY_RXP	-	A	-	-	-
F7	EPHY_SPD_LED	-	A	-	-	-
A3	EPHY_TXN	-	A	-	-	-
B3	EPHY_TXP	-	A	-	-	-
G7	EPHY_VCC	-	P	-	-	-
F8	EPHY_VDD	-	P	-	-	-
<b>JTAG</b>						
A1	JTAG-SEL0	-	I	-	Pull-Up	-
B2	JTAG-SEL1	-	I	-	Pull-Up	-
<b>ADC</b>						
AA5	KEYADC	-	A	-	-	-
<b>TV</b>						
H8	GND_TV	-	G	-	-	-
F10	TVOUT	-	A	-	-	-
G9	V33_TV	-	P	-	-	-
<b>RTC</b>						
M4	RTC_VIO	-	P	-	-	-
V5	X32KIN	-	A	-	-	-
U4	X32KOUT	-	A	-	-	-
<b>CPU</b>						
T10	VDD-CPUFB	-	I/O	-	-	-
T9	GND-CPUFB	-	G	-	-	-
<b>Power</b>						



Ball#	Pin Name	Default Function	Type	Reset State	Default Pull Up/Down	Buffer Strength (mA)
H11	VDD_EFUSEEBP	-	P	-	-	-
G10	VDD_EFUSE	-	P	-	-	-
N8,P6,P7,P8,P9,R6, R7, R8,T6,T7,T8,U6,U9	VDD_CPUX	-	P	-	-	-
J7,J8	VDD_CPUS	-	P	-	-	-
H10,J10,J11,J12,K1 0,K11,K12,L10,L11, L12,L13, L14	VDD-SYS	-	P	-	-	-
A21,AA1,G8,H12,H 15, J13,J16,J9,K13,K14, K15, K16,K7,K8,K9,L15,L 8,L9,M10,M11,M1 2,M13,M14,M15,M 7,M8,M9,N10,N11, N12,N13,N14,N15, N7,N9,P10,P11,P12 .P13,P14,P15,R10, R11,R12,R13,R14,R 9,T11	GND	-	G	-	-	-
<b>Other</b>						
K4	NC	-	-	-	-	-

**Note:**

- 1) **Default Function** defines the default function of each pin, especially for pins with multiplexing functions;
- 2) **Type** defines the signal direction: I (Input), O (Output), I/O(Input / Output), OD(Open-Drain), A (Analog), AI(Analog Input), AO(Analog Output),A I/O(Analog Input /Output), P (Power), G (Ground);
- 3) **Reset State** defines the state of the terminal at reset: Z for high-impedance ;
- 4) **Default Pull Up/Down** defines the presence of an internal pull up or pull down resistor. Unless otherwise specified, the pin is default to be floating, and can be configured as pull up or pull down;
- 5) **Buffer Strength** defines drive strength of the associated output buffer.

### 3.2. GPIO Multiplexing Functions

The following table provides a description of the H3 GPIO multiplexing functions.

Table 3-2. Multiplexing Functions

Pin Name	Default Function	IO Type	Default IO State	Default Pull-up/down	Function 2	Function3	Function 4	Function 5	Function 6
PA0	GPIO	I/O	DIS	Z	UART2_TX	JTAG_MS	-	-	PA_EINT0
PA1		I/O	DIS	Z	UART2_RX	JTAG_CK	-	-	PA_EINT1
PA2		I/O	DIS	Z	UART2_RTS	JTAG_DO	-	-	PA_EINT2
PA3		I/O	DIS	Z	UART2_CTS	JTAG_DI	-	-	PA_EINT3
PA4		I/O	DIS	Z	UART0_TX	-	-	-	PA_EINT4
PA5		I/O	DIS	Z	UART0_RX	PWM0	-	-	PA_EINT5
PA6		I/O	DIS	Z	SIM_PWREN	PWM1	-	-	PA_EINT6
PA7		I/O	DIS	Z	SIM_CLK	-	-	-	PA_EINT7
PA8		I/O	DIS	Z	SIM_DATA	-	-	-	PA_EINT8
PA9		I/O	DIS	Z	SIM_RST	-	-	-	PA_EINT9
PA10		I/O	DIS	Z	SIM_DET	-	-	-	PA_EINT10
PA11		I/O	DIS	Z	TWI0_SCK	DI_TX	-	-	PA_EINT11
PA12		I/O	DIS	Z	TWI0_SDA	DI_RX	-	-	PA_EINT12
PA13		I/O	DIS	Z	SPI1_CS	UART3_TX	-	-	PA_EINT13
PA14		I/O	DIS	Z	SPI1_CLK	UART3_RX	-	-	PA_EINT14
PA15		I/O	DIS	Z	SPI1_MOSI	UART3_RTS	-	-	PA_EINT15
PA16		I/O	DIS	Z	SPI1_MISO	UART3_CTS	-	-	PA_EINT16
PA17		I/O	DIS	Z	OWA_OUT	-	-	-	PA_EINT17
PA18		I/O	DIS	Z	PCM0_SYNC	TWI1_SCK	-	-	PA_EINT18
PA19		I/O	DIS	Z	PCM0_CLK	TWI1_SDA	-	-	PA_EINT19
PA20		I/O	DIS	Z	PCM0_DOUT	SIM_VPPEN	-	-	PA_EINT20
PA21	I/O	DIS	Z	PCM0_DIN	SIM_VPPPP	-	-	PA_EINT21	
PC0	GPIO	I/O	DIS	Z	NAND_WE	SPIO_MOSI	-	-	-
PC1		I/O	DIS	Z	NAND_ALE	SPIO_MISO	-	-	-
PC2		I/O	DIS	Z	NAND_CLE	SPIO_CLK	-	-	-
PC3		I/O	DIS	Pull-up	NAND_CE1	SPIO_CS	-	-	-
PC4		I/O	DIS	Pull-up	NAND_CE0	-	-	-	-
PC5		I/O	DIS	Z	NAND_RE	SDC2_CLK	-	-	-
PC6		I/O	DIS	Pull-up	NAND_RB0	SDC2_CMD	-	-	-
PC7		I/O	DIS	Pull-up	NAND_RB1	-	-	-	-
PC8		I/O	DIS	Z	NAND_DQ0	SDC2_D0	-	-	-
PC9		I/O	DIS	Z	NAND_DQ1	SDC2_D1	-	-	-
PC10		I/O	DIS	Z	NAND_DQ2	SDC2_D2	-	-	-
PC11	I/O	DIS	Z	NAND_DQ3	SDC2_D3	-	-	-	

Pin Name	Default Function	IO Type	Default IO State	Default Pull-up/down	Function 2	Function3	Function 4	Function 5	Function 6
PC12		I/O	DIS	Z	NAND_DQ4	SDC2_D4	-	-	-
PC13		I/O	DIS	Z	NAND_DQ5	SDC2_D5	-	-	-
PC14		I/O	DIS	Z	NAND_DQ6	SDC2_D6	-	-	-
PC15		I/O	DIS	Z	NAND_DQ7	SDC2_D7	-	-	-
PC16		I/O	DIS	Z	NAND_DQS	SDC2_RST	-	-	-
PD0	GPIO	I/O	DIS	Z	RGMII_RXD3/ MII_RXD3/ RMII_NULL	-	-	-	-
PD1		I/O	DIS	Z	RGMII_RXD2/ MII_RXD2/RM II_NULL	-	-	-	-
PD2		I/O	DIS	Z	RGMII_RXD1/ MII_RXD2/RM II_RXD1	-	-	-	-
PD3		I/O	DIS	Z	RGMII_RXD0/ MII_RXD1/RM II_RXD0	-	-	-	-
PD4		I/O	DIS	Z	RGMII_RXCK/ MII_RXCK/RM I_NULL	-	-	-	-
PD5		I/O	DIS	Z	RGMII_RXCTL/ MII_RXDV/RM II_NULL	-	-	-	-
PD6		I/O	DIS	Z	RGMII_NULL/ MII_RXERR/R MII_RXER	-	-	-	-
PD7		I/O	DIS	Z	RGMII_TXD3/ MII_TXD3/RM I_NULL	-	-	-	-
PD8		I/O	DIS	Z	RGMII_TXD2/ MII_TXD2/RM I_NULL	-	-	-	-
PD9		I/O	DIS	Z	RGMII_TXD1/ MII_TXD1/RM I_TXD1	-	-	-	-
PD10		I/O	DIS	Z	RGMII_TXD0/ MII_TXD0/RM I_TXD0	-	-	-	-
PD11		I/O	DIS	Z	RGMII_NULL/ MII_CRS/RMII _CRS_DV	-	-	-	-
PD12	I/O	DIS	Z	RGMII_TXCK/ MII_TXCK/RM I_TXCK	-	-	-	-	

Pin Name	Default Function	IO Type	Default IO State	Default Pull-up/down	Function 2	Function3	Function 4	Function 5	Function 6
					MII_TXCK/RMI I_TXCK				
PD13		I/O	DIS	Z	RGMII_TXCTL/ MII_TXEN/RMI I_TXEN	-	-	-	-
PD14		I/O	DIS	Z	RGMII_NULL/ MII_TXERR/R MII_NULL	-	-	-	-
PD15		I/O	DIS	Z	RGMII_CLKIN/ MII_COL/RMII _NULL	-	-	-	-
PD16		I/O	DIS	Z	MDC	-	-	-	-
PD17		I/O	DIS	Z	MDIO	-	-	-	-
PE0	GPIO	I/O	DIS	Z	CSI_PCLK	TS_CLK	-	-	-
PE1		I/O	DIS	Z	CSI_MCLK	TS_ERR	-	-	-
PE2		I/O	DIS	Z	CSI_HSYNC	TS_SYNC	-	-	-
PE3		I/O	DIS	Z	CSI_VSYNC	TS_DVLD	-	-	-
PE4		I/O	DIS	Z	CSI_D0	TS_D0	-	-	-
PE5		I/O	DIS	Z	CSI_D1	TS_D1	-	-	-
PE6		I/O	DIS	Z	CSI_D2	TS_D2	-	-	-
PE7		I/O	DIS	Z	CSI_D3	TS_D3	-	-	-
PE8		I/O	DIS	Z	CSI_D4	TS_D4	-	-	-
PE9		I/O	DIS	Z	CSI_D5	TS_D5	-	-	-
PE10		I/O	DIS	Z	CSI_D6	TS_D6	-	-	-
PE11		I/O	DIS	Z	CSI_D7	TS_D7	-	-	-
PE12		I/O	DIS	Z	CSI_SCK	TWI2_SCK	-	-	-
PE13		I/O	DIS	Z	CSI_SDA	TWI2_SDA	-	-	-
PE14		I/O	DIS	Z	-	-	-	-	-
PE15		I/O	DIS	Z	-	-	-	-	-
PF0	GPIO	I/O	JTAG_MS	Z	SDC0_D1	JTAG_MS	-	-	-
PF1		I/O	JTAG_DI	Z	SDC0_D0	JTAG_DI	-	-	-
PF2		I/O	DIS	Z	SDC0_CLK	UART0_TX	-	-	-
PF3		I/O	JTAG_DO	Z	SDC0_CMD	JTAG_DO	-	-	-
PF4		I/O	DIS	Z	SDC0_D3	UART0_RX	-	-	-
PF5		I/O	JTAG_CK	Z	SDC0_D2	JTAG_CK	-	-	-
PF6		I/O	DIS	Z	SDC0_DET	-	-	-	-
PG0	GPIO	I/O	DIS	Z	SDC1_CLK	-	-	-	PG_EINT0
PG1		I/O	DIS	Z	SDC1_CMD	-	-	-	PG_EINT1
PG2		I/O	DIS	Z	SDC1_D0	-	-	-	PG_EINT2
PG3		I/O	DIS	Z	SDC1_D1	-	-	-	PG_EINT3
PG4		I/O	DIS	Z	SDC1_D2	-	-	-	PG_EINT4

Pin Name	Default Function	IO Type	Default IO State	Default Pull-up/down	Function 2	Function3	Function 4	Function 5	Function 6
PG5		I/O	DIS	Z	SDC1_D3	-	-	-	PG_EINT5
PG6		I/O	DIS	Z	UART1_TX	-	-	-	PG_EINT6
PG7		I/O	DIS	Z	UART1_RX	-	-	-	PG_EINT7
PG8		I/O	DIS	Z	UART1_RTS	-	-	-	PG_EINT8
PG9		I/O	DIS	Z	UART1_CTS	-	-	-	PG_EINT9
PG10		I/O	DIS	Z	PCM1_SYNC	-	-	-	PG_EINT10
PG11		I/O	DIS	Z	PCM1_CLK	-	-	-	PG_EINT11
PG12		I/O	DIS	Z	PCM1_DOUT	-	-	-	PG_EINT12
PG13		I/O	DIS	Z	PCM1_DIN	-	-	-	PG_EINT13
PL0	GPIO	I/O	DIS	Pull-up	S_TWI_SCK	-	-	-	S_PL_EINT0
PL1		I/O	DIS	Pull-up	S_TWI_SDA	-	-	-	S_PL_EINT1
PL2		I/O	DIS	Z	S_UART_TX	-	-	-	S_PL_EINT2
PL3		I/O	DIS	Z	S_UART_RX	-	-	-	S_PL_EINT3
PL4		I/O	DIS	Z	S_JTAG_MS	-	-	-	S_PL_EINT4
PL5		I/O	DIS	Z	S_JTAG_CK	-	-	-	S_PL_EINT5
PL6		I/O	DIS	Z	S_JTAG_DO	-	-	-	S_PL_EINT6
PL7		I/O	DIS	Z	S_JTAG_DI	-	-	-	S_PL_EINT7
PL8		I/O	DIS	Z	-	-	-	-	S_PL_EINT8
PL9		I/O	DIS	Z	-	-	-	-	S_PL_EINT9
PL10		I/O	DIS	Z	S_PWM	-	-	-	S_PL_EINT10
PL11		I/O	DIS	Z	S_CIR_RX	-	-	-	S_PL_EINT12

### 3.3. Detailed Pin/Signal Description

Table 3-3 shows the detailed function description of every pin/signal based on the different interface.

Table 3-3. Detailed Pin/Signal Description

Pin/Signal Name	Description	Type
<b>DRAM</b>		
SDQ[31:0]	DRAM bidirectional data line to the memory device	I/O
SDQS[3:0]	DRAM active-high bidirectional data strobes to the memory device	I/O
SDQSB[3:0]	DRAM active-low bidirectional data strobes to the memory device	I/O
SDQM[3:0]	DRAM data mask signal to the memory device	O
SCK	DRAM active-high clock signal to the memory device	O
SCKB	DRAM active-low clock signal to the memory device	O
SCKE[1:0]	DRAM clock enable signal to the memory device for two chip select	O
SA[15:0]	DRAM address signal to the memory device	O
SWE	DRAM write enable strobe to the memory device	O
SCAS	DRAM column address strobe to the memory device	O
SRAS	DRAM row address strobe to the memory device	O
SCS[1:0]	DRAM chip select signal to the memory device	O
SBA[2:0]	DRAM bank address signal to the memory device	O
SODT[1:0]	DRAM On-Die Termination output signal for two chip select	O
SRST	DRAM reset signal to the memory device	O
SZQ	DRAM ZQ Calibration	A
SVREF	DRAM Reference Input	P
VCC-DRAM	DRAM Power Supply	P
<b>System</b>		
UBOOT	UBOOT Signal	I
TEST	TEST Signal	I
NMI	Non-Maskable Interrupt	I
RESET	RESET Signal	I
X32KFOUT	Clock Output Of 32768Hz LOSC	OD
X24MIN	Clock Input Of 24MHz Crystal	AI
X24MOUT	Clock Output Of 24MHz Crystal	AO
X32KIN	Clock Input Of 32KHz Crystal	AI
X32KOUT	Clock Output Of 32KHz Crystal	AO
VCC_RTC	RTC Power Supply	P
REXT	External Reference Register	AI
RTC-VIO	Internal LDO Output Bypass	P
<b>HDMI</b>		
HTX0P	HDMI positive TMDS differential line driver data0 output	AO
HTX0N	HDMI negative TMDS differential line driver data0 output	AO
HTX1P	HDMI positive TMDS differential line driver data1 output	AO

Pin/Signal Name	Description	Type
HTX1N	HDMI negative TMDS differential line driver data1 output	AO
HTX2P	HDMI positive TMDS differential line driver data2 output	AO
HTX2N	HDMI negative TMDS differential line driver data2 output	AO
HTXCP	HDMI positive TMDS differential line driver clock output	AO
HTXCN	HDMI negative TMDS differential line driver clock output	AO
HVCC	HDMI Power Supply	P
HHPD	HDMI Hot Plug Detection signal	I/O
HCEC	HDMI Consumer Electronics Control	I/O
HSCL	HDMI DDC Clock	O
HSDA	HDMI DDC Data	O
<b>USB</b>		
USB_DM0	USB DM Signal	A I/O
USB_DP0	USB DP Signal	A I/O
USB_DM1	USBDM Signal	A I/O
USB_DP1	USB DP Signal	A I/O
USB_DM2	USB DM Signal	A I/O
USB_DP2	USB DP Signal	A I/O
USB_DM3	USB DM Signal	A I/O
USB_DP3	USB DP Signal	A I/O
VCC_USB	USB Power Supply	P
<b>ADC</b>		
KEYADC	KEYADC input	AI
<b>AUDIO CODEC</b>		
LINEINL	LINE-IN Left Channel Input	AI
LINEINR	LINE-IN Right Channel Input	AI
LINEOUTL	LINE-OUT Left Channel Output	AO
LINEOUTR	LINE-OUT Right Channel Output	AO
MBIAS	Master Analog Microphone Bias	AO
MICIN1N	Microphone Negative Input 1	AI
MICIN1P	Microphone Positive Input 1	AI
MICIN2N	Microphone Negative Input 2	AI
MICIN2P	Microphone Positive Input 2	AI
VRA1	Reference Voltage	AO
VRA2	Reference Voltage	AO
VRP	Reference Voltage	AO
AVCC	Analog Power	P
AGND	Analog GND	G
<b>I2S/PCM</b>		
PCM0_SYNC	I2S/PCM Sample Rate Clock/Sync	I/O
PCM0_BCLK	I2S/PCM Sample Rate Clock	I/O
PCM0_DOUT	I2S/PCM Serial Data Output	O
PCM0_DIN	I2S/PCM Serial Data Input	I

Pin/Signal Name	Description	Type
<b>EPHY</b>		
EPHY_RXP	Transceiver Positive Output/Input	A I/O
EPHY_RXN	Transceiver Negative Output/Input	A I/O
EPHY_TXP	Transceiver Positive Output/Input	A I/O
EPHY_TXN	Transceiver Negative Output/Input	A I/O
EPHY_RTX	EPHY External Resistance to Ground	AI
EPHY_LINK_LED	EPHY LINK Up/Down Indicator LED	O
EPHY_SPD_LED	EPHY 10M/100M Indicator LED	O
EPHY_VDD	Analog Power Supply for EPHY	P
EPHY_VCC	Analog Power Supply for EPHY	P
<b>SD /MMC</b>		
SDC0_CMD	Command Signal for SD/TF Card	I/O
SDC0_CLK	Clock for SD/TF Card	O
SDC0_D[3:0]	Data Input and Output for SD/TF Card	I/O
SDC1_CMD	Command Signal for SDIO WIFI	I/O
SDC1_CLK	Clock for SDIO WIFI	O
SDC1_D[3:0]	Data Input and Output for SDIO WIFI	I/O
SDC2_CMD	Command Signal for SD/eMMC	I/O
SDC2_CLK	Clock for SD/eMMC	O
SDC2_D[7:0]	Data Input and Output for SD/eMMC	I/O
SDC2_RST	Reset Signal for SD/eMMC	O
<b>NAND FLASH</b>		
NAND_DQ[7:0]	NAND Flash0 Data Bit [7:0]	I/O
NAND_DQS	NAND Flash Data Strobe	I/O
NAND_WE	NAND Flash Write Enable	O
NAND_RE	NAND Flash chip Read Enable	O
NAND_ALE	NAND Flash Address Latch Enable	O
NAND_CLE	NAND Command Latch Enable	O
NAND_CE[1:0]	NAND Flash Chip Select [1:0]	O
NAND_RB[1:0]	NAND Flash Ready/Busy Bit	I
<b>Interrupt</b>		
PA_EINT[21:0]	GPIO A Interrupt	I
PG_EINT[13:0]	GPIO G Interrupt	I
S_PL_EINT[11:0]	GPIO L Interrupt	I
<b>PWM</b>		
S_PWM	Pulse Width Modulation output	O
PWM0	Pulse Width Modulation output	O
PWM1	Pulse Width Modulation output	O
<b>IR</b>		
S_CIR_RX	IR Data Receive	I
<b>CSI</b>		
CSI_PCLK	CSI Pixel Clock	I



Pin/Signal Name	Description	Type
CSI_MCLK	CSI Master Clock	O
CSI_HSYNC	CSI Horizontal SYNC	I
CSI_VSYNC	CSI Vertical SYNC	I
CSI_D[7:0]	CSI Data bit [7:0]	I
CSI_SCK	CSI Command Serial Clock Signal	I/O
CSI_SDA	CSI Command Serial Data Signal	I/O
<b>EMAC</b>		
RGMII_RXD3/MII_RXD3/ /RMII_NULL	RGMII/MII Receive Data	I
RGMII_RXD2/MII_RXD2/ RMII_NULL	RGMII/MII Receive Data	I
RGMII_RXD1/MII_RXD1/ RMII_RXD1	RGMII/MII /RMII Receive Data	I
RGMII_RXD0/MII_RXD0/ RMII_RXD0	RGMII/MII /RMII Receive Data	I
RGMII_RXCK/MII_RXCK/ RMII_NULL	RGMII/MII Receive Clock	I
RGMII_RXCTL/MII_RXDV/ RMII_CRS_DV	RGMII Receive Control/MII Receive Enable/RMII Carrier Sense-Receive Data Valid	I
RGMII_NULL/MII_RXERR/ RMII_RXER	MII/RMII Receive Error	I
RGMII_TXD3/MII_TXD3/ RMII_NULL	RGMII/MII Transmit Data	O
RGMII_TXD2/MII_TXD2/ RMII_NULL	RGMII/MII Transmit Data	O
RGMII_TXD1/MII_TXD1/ RMII_TXD1	RGMII/MII /RMII Transmit Data	O
RGMII_TXD0/MII_TXD0/ RMII_TXD0	RGMII/MII /RMII Transmit Data	O
RGMII_NULL/MII_CRS/ RMII_NULL	MII Carrier Sense	I
RGMII_TXCK/MII_TXCK/ RMII_TXCK	RGMII/MII /RMII Transmit Clock: Output Pin for RGMII, Input Pin for MII/RMII	I/O
RGMII_TXCTL/MII_TXEN/ RMII_TXEN	RGMII Transmit Control/MII Transmit Enable/RMII Transmit Enable: Output Pin for RGMII/RMII, Input Pin for MII	I/O
RGMII_NULL/MII_TXERR/ RMII_NULL	MII Transmit Error	O
RGMII_CLKIN/MII_COL/ RMII_NULL	RGMII Transmit Clock from External/MII Collision Detect	I
MDC	RGMII/MII /RMII Management Data Clock	O
MDIO	RGMII/MII /RMII Management Data Input/Output	I/O
<b>TRANSPORT STREAM</b>		
TS_CLK	Transport Stream Clock	I

Pin/Signal Name	Description	Type
TS_ERR	Transport Stream Error Indicate	I
TS_SYNC	Transport Stream Sync	I
TS_DVLD	Transport Stream Valid Signal	I
TS_D[7:0]	Transport Stream Data	I
<b>SPI (x=[1:0])</b>		
SPIx_CS	SPIx Chip Select signal, low active	I/O
SPIx_CLK	SPIx Clock signal	I/O
SPIx_MOSI	SPIx Master data Out, Slave data In	I/O
SPIx_MISO	SPIx Master data In, Slave data Out	I/O
<b>UART</b>		
UART0_TX	UART0 Data Transmit	O
UART0_RX	UART0 Data Receive	I
UART1_TX	UART1 Data Transmit	O
UART1_RX	UART1 Data Receive	I
UART1_CTS	UART1 Data Clear To Send	I
UART1_RTS	UART1 Data Request To Send	O
UART2_TX	UART2 Data Transmit	O
UART2_RX	UART2 Data Receive	I
UART2_CTS	UART2 Data Clear To Send	I
UART2_RTS	UART2 Data Request To Send	O
UART3_TX	UART3 Data Transmit	O
UART3_RX	UART3 Data Receive	I
UART3_CTS	UART3 Data Clear To Send	I
UART3_RTS	UART3 Data Request To Send	O
S_UART_TX	UART Data Transmit	O
S_UART_RX	UART Data Receive	I
<b>TWI (x=[2:0])</b>		
TWix_SCK	TWix Serial Clock Signal	I/O
TWix_SDA	TWix Serial Data Signal	I/O
S_TWI_SCK	TWI Serial Clock Signal	I/O
S_TWI_SDA	TWI Serial Data Signal	I/O

## Chapter 4 System

The chapter describes the H3 system from following sections:

- Memory Mapping
- Boot System
- CCU
- CPU Configuration
- System Control
- Timer
- Trusted Watchdog
- RTC
- High-speed Timer
- PWM
- DMA
- GIC
- Message Box
- Spinlock
- Crypto Engine
- Security ID
- Secure Memory Controller
- Secure Memory Touch Arbiter
- Thermal Sensor Controller
- KEY\_ADC
- Audio Codec
- Port Controller(CPU-PORT)
- Port Controller(CPUs-PORT)

Confidential

## 4.1. Memory Mapping

Module	Address (It is for Cluster CPU)	Size (byte)
SRAM A1	0x0000 0000---0x0000 FFFF	64K
SRAM A2	0x0004 4000---0x0004 BFFF	32K
SRAM C	0x0001 0000---0x0001 AFFF	44K
DE	0x0100 0000---0x013F FFFF	4M
De-interlaced	0x0140 0000---0x0141 FFFF	128K
System Control	0x01C0 0000---0x01C0 0FFF	4K
DMA	0x01C0 2000---0x01C0 2FFF	4K
NFDC	0x01C0 3000---0x01C0 3FFF	4K
TS	0x01C0 6000---0x01C0 6FFF	4K
Key Memory Space	0x01C0 B000---0x01C0 BFFF	4K
LCD 0	0x01C0 C000---0x01C0 CFFF	4K
LCD 1	0x01C0 D000---0x01C0 DFFF	4K
VE	0x01C0 E000---0x01C0 EFFF	4K
SD/MMC 0	0x01C0 F000---0x01C0 FFFF	4K
SD/MMC 1	0x01C1 0000---0x01C1 0FFF	4K
SD/MMC 2	0x01C1 1000---0x01C1 1FFF	4K
SID	0x01C1 4000---0x01C1 43FF	1K
Crypto Engine	0x01C1 5000---0x01C1 5FFF	4K
MSG_BOX	0x01C1 7000---0x01C1 7FFF	4K
SPINLOCK	0x01C1 8000---0x01C1 8FFF	4K
USB-OTG_Device	0x01C1 9000---0x01C1 9FFF	4K
USB-OTG_EHCI0/OHCI0	0x01C1 A000---0x01C1 AFFF	4K
USB-HCI1	0x01C1 B000---0x01C1 BFFF	4K
USB-HCI2	0x01C1 C000---0x01C1 CFFF	4K
USB-HCI3	0x01C1 D000---0x01C1 DFFF	4K
SMC	0x01C1 E000---0x01C1 EFFF	4K
CCU	0x01C2 0000---0x01C2 03FF	1K
PIO	0x01C2 0800---0x01C2 0BFF	1K
TIMER	0x01C2 0C00---0x01C2 0FFF	1K
OWA	0x01C2 1000---0x01C2 13FF	1K
PWM	0x01C2 1400---0x01C2 17FF	1K
KEYADC	0x01C2 1800---0x01C2 1BFF	1K
I2S/PCM 0	0x01C2 2000---0x01C2 23FF	1K
I2S/PCM 1	0x01C2 2400---0x01C2 27FF	1K
I2S/PCM 2	0x01C2 2800---0x01C2 2BFF	1K
AC	0x01C2 2C00---0x01C2 33FF	2K
SMTA	0x01C2 3400---0x01C2 37FF	1K
THS	0x01C2 5000---0x01C2 53FF	1K
UART 0	0x01C2 8000---0x01C2 83FF	1K

UART 1	0x01C2 8400---0x01C2 87FF	1K
UART 2	0x01C2 8800---0x01C2 8BFF	1K
UART 3	0x01C2 8C00---0x01C2 8FFF	1K
TWI 0	0x01C2 AC00---0x01C2 AFFF	1K
TWI 1	0x01C2 B000---0x01C2 B3FF	1K
TWI 2	0x01C2 B400---0x01C2 B7FF	1K
SCR	0x01C2 C400---0x01C2 C7FF	1K
EMAC	0x01C3 0000---0x01C3 FFFF	64K
GPU	0x01C4 0000---0x01C4 FFFF	64K
HSTMR	0x01C6 0000---0x01C6 0FFF	4K
DRAMCOM	0x01C6 2000---0x01C6 2FFF	4K
DRAMCTLO	0x01C6 3000---0x01C6 3FFF	4K
DRAMPHY0	0x01C6 5000---0x01C6 5FFF	4K
SPI0	0x01C6 8000---0x01C6 8FFF	4K
SPI1	0x01C6 9000---0x01C6 9FFF	4K
SCU	0x01C80000 GIC_DIST: 0x01C80000 + 0x1000 GIC_CPUIF:0x01C80000 + 0x2000	
CSI	0x01CB 0000---0x01CF FFFF	320K
TVE	0x01E0 0000---0x01E0 FFFF	64K
HDMI	0x01EE 0000---0x01EF FFFF	128K
RTC	0x01F0 0000---0x01F0 03FF	1K
R_TIMER	0x01F0 0800---0x01F0 0BFF	1K
R_INTC	0x01F0 0C00---0x01F0 0FFF	1K
R_WDOG	0x01F0 1000---0x01F0 13FF	1K
R_PRCM	0x01F0 1400---0x01F0 17FF	1K
R_TWD	0x01F0 1800---0x01F0 1BFF	1K
R_CPUCFG	0x01F0 1C00---0x01F0 1FFF	1K
R_CIR-RX	0x01F0 2000---0x01F0 23FF	1K
R_TWI	0x01F0 2400---0x01F0 27FF	1K
R_UART	0x01F0 2800---0x01F0 2BFF	1K
R_PIO	0x01F0 2C00---0x01F0 2FFF	1K
R_PWM	0x01F0 3800---0x01F0 3BFF	1K
CoreSight Debug	0x3F50 0000---0x3F51 FFFF	128K
TSGEN RO	0x3F50 6000---0x3F50 6FFF	4K
TSGEN CTRL	0x3F50 7000---0x3F50 7FFF	4K
DDR-III/LPDDR-II	0x4000 0000---0xBFFF FFFF	2G
N-BROM	0xFFFF 0000---0xFFFF 7FFF	32K
S-BROM	0xFFFF 0000---0xFFFF FFFF	64K

## 4.2. Boot System

The Boot System includes the following features:

- The system will boot in different ways based on whether its security features are enabled
- Support CPU-0 boot process and CPU-0+ boot process
- Support super standby wakeup process
- Support mandatory upgrade process through SDC0 and USB OTG
- Support fast boot process from Raw NAND,eMMC,SD/TF card ,and SPI NOR Flash

Confidential

## 4.3. CCU

### 4.3.1. Overview

The CCU controls the PLLs configuration and most of the clock generation, division, distribution, synchronization and gating. CCU input signals include the external clock for the reference frequency (24MHz). The outputs from CCU are mostly clocks to other blocks in the system.

The CCU includes the following features:

- 9 PLLs, independent PLL for CPUX
- Bus Source and Divisions
- PLLs Bias Control
- PLLs Tuning Control
- PLLs Pattern Control
- Configuring Modules Clock
- Bus Clock Gating
- Bus Software Reset

### 4.3.2. Functionalities Description

#### 4.3.2.1. System Bus

Confidential

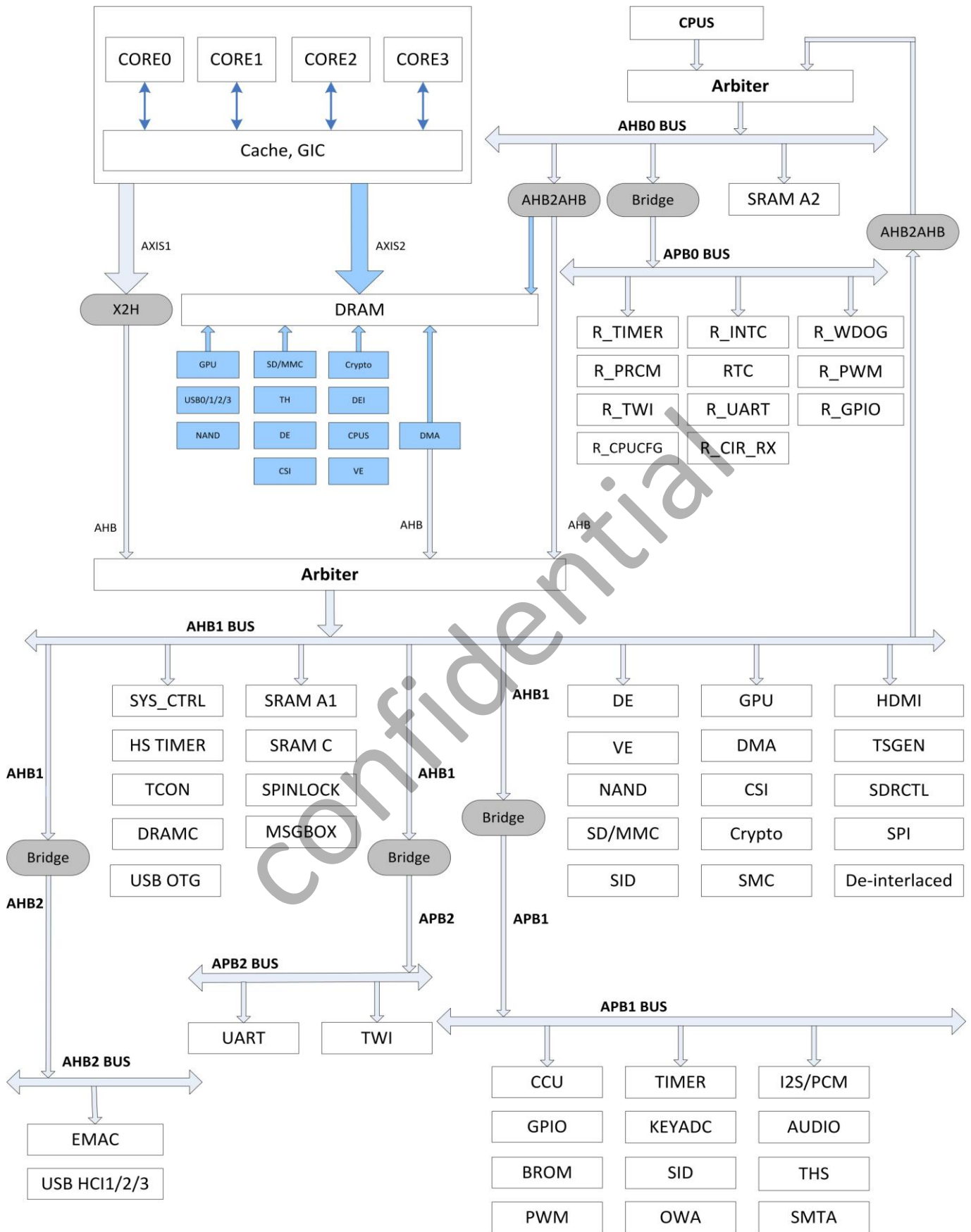

Figure 4-1. System Bus Tree



4.3.2.2. Bus clock tree

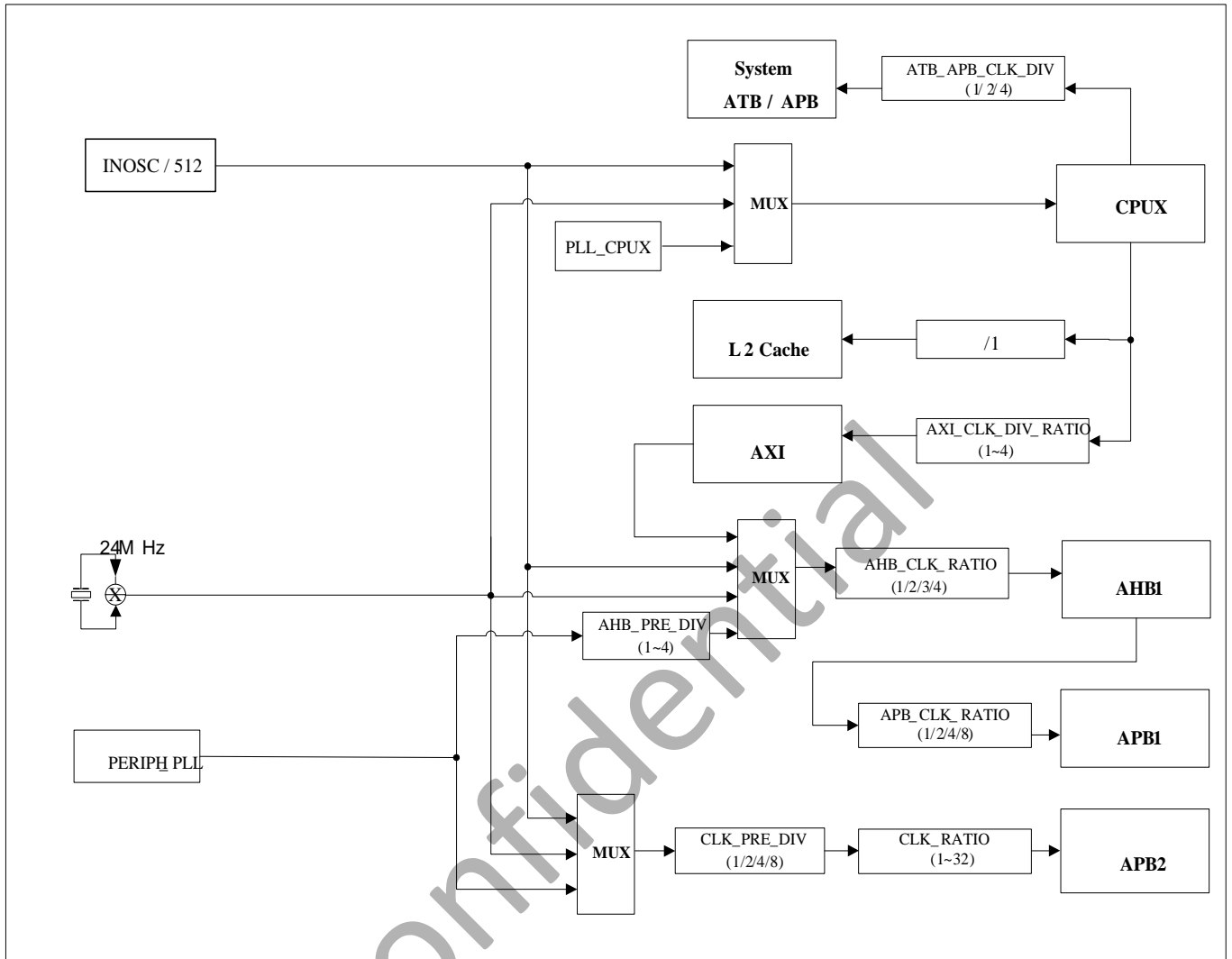

Figure 4-2. Bus Clock Tree

4.3.3. Typical Applications

- Clock output of PLL\_CPUX is used only for CPUX, and the frequency factor can be dynamically modified for DVFS;
- Clock output of PLL\_AUDIO can be used for I2S/PCM, AC DIGITAL, OWA etc, and dynamic frequency scaling is not supported;
- Clock output of PLL\_PERIPH0 can be used for MBUS/AHB1/AHB2/APB1/APB2 and NAND/MMC/Crypto Engine /SPI /CSI/ DE /DEINTERLACE etc, and dynamic frequency scaling is not supported;
- Clock output of PLL\_PERIPH1 can be used for NAND/MMC/SPI/CSI/TVE/DEINTERLACE etc, and dynamic frequency scaling is not supported;
- Clock output of PLL\_VE can be used for VE , and dynamic frequency scaling is not supported;
- Clock output of PLL\_DDR can be used for MBUS and DRAM, and dynamic frequency scaling is not supported;
- Clock output of PLL\_VIDEO0 can be used for DE, TCON ,HDMI and CSI, and dynamic frequency scaling is not supported;
- Clock output of PLL\_DE can be used for DE,TCON and TVE, and dynamic frequency scaling is not supported;
- Clock output of PLL\_HSIC can be used for CCI-400 and USBPHY, and dynamic frequency scaling is not supported;

Clock output of PLL\_GPU can be used for GPU, and dynamic frequency scaling is not supported;

### 4.3.4. Register List

Module Name	Base Address
CCU	0x01C20000

Register Name	Offset	Description
PLL_CPUX_CTRL_REG	0x0000	PLL_CPUX Control Register
PLL_AUDIO_CTRL_REG	0x0008	PLL_AUDIO Control Register
PLL_VIDEO_CTRL_REG	0x0010	PLL_VIDEO Control Register
PLL_VE_CTRL_REG	0x0018	PLL_VE Control Register
PLL_DDR_CTRL_REG	0x0020	PLL_DDR Control Register
PLL_PERIPH0_CTRL_REG	0x0028	PLL_PERIPH0 Control Register
PLL_GPU_CTRL_REG	0x0038	PLL_GPU Control Register
PLL_PERIPH1_CTRL_REG	0x0044	PLL_PERIPH1_CTRL_REG
PLL_DE_CTRL_REG	0x0048	PLL_DE Control Register
CPUX_AXI_CFG_REG	0x0050	CPUX/AXI Configuration Register
AHB1_APB1_CFG_REG	0x0054	AHB1/APB1 Configuration Register
APB2_CFG_REG	0x0058	APB2 Configuration Register
AHB2_CFG_REG	0x005C	AHB2 Configuration Register
BUS_CLK_GATING_REG0	0x0060	Bus Clock Gating Register 0
BUS_CLK_GATING_REG1	0x0064	Bus Clock Gating Register 1
BUS_CLK_GATING_REG2	0x0068	Bus Clock Gating Register 2
BUS_CLK_GATING_REG3	0x006C	Bus Clock Gating Register 3
BUS_CLK_GATING_REG4	0x0070	Bus Clock Gating Register4
THS_CLK_REG	0x0074	THS Clock Register
NAND_CLK_REG	0x0080	NAND Clock Register
SDMMC0_CLK_REG	0x0088	SDMMC0 Clock Register
SDMMC1_CLK_REG	0x008C	SDMMC1 Clock Register
SDMMC2_CLK_REG	0x0090	SDMMC2 Clock Register
CE_CLK_REG	0x009C	CE Clock Register
SPI0_CLK_REG	0x00A0	SPI0 Clock Register
SPI1_CLK_REG	0x00A4	SPI1 Clock Register
I2S/PCM0_CLK_REG	0x00B0	I2S/PCM0 Clock Register
I2S/PCM1_CLK_REG	0x00B4	I2S/PCM1 Clock Register
I2S/PCM2_CLK_REG	0x00B8	I2S/PCM2 Clock Register
OWA_CLK_REG	0x00C0	OWA Clock Register
USBPHY_CFG_REG	0x00CC	USBPHY Configuration Register
DRAM_CFG_REG	0x00F4	DRAM Configuration Register
MBUS_RST_REG	0x00FC	MBUS Reset Register
DRAM_CLK_GATING_REG	0x0100	DRAM Clock Gating Register
TCON0_CLK_REG	0x0118	TCON0 Clock Register

TVE_CLK_REG	0x0120	TVE Clock Register
DEINTERLACE_CLK_REG	0x0124	DEINTERLACE Clock Register
CSI_MISC_CLK_REG	0x0130	CSI_MISC Clock Register
CSI_CLK_REG	0x0134	CSI Clock Register
VE_CLK_REG	0x013C	VE Clock Register
AC_DIG_CLK_REG	0x0140	AC Digital Clock Register
AVS_CLK_REG	0x0144	AVS Clock Register
HDMI_CLK_REG	0x0150	HDMI Clock Register
HDMI_SLOW_CLK_REG	0x0154	HDMI Slow Clock Register
MBUS_CLK_REG	0x015C	MBUS Clock Register
GPU_CLK_REG	0x01A0	GPU Clock Register
PLL_STABLE_TIME_REG0	0x0200	PLL Stable Time Register 0
PLL_STABLE_TIME_REG1	0x0204	PLL Stable Time Register 1
PLL_CPUX_BIAS_REG	0x0220	PLL_CPUX Bias Register
PLL_AUDIO_BIAS_REG	0x0224	PLL_AUDIO Bias Register
PLL_VIDEO_BIAS_REG	0x0228	PLL_VIDEO Bias Register
PLL_VE_BIAS_REG	0x022C	PLL_VE Bias Register
PLL_DDR_BIAS_REG	0x0230	PLL_DDR Bias Register
PLL_PERIPH0_BIAS_REG	0x0234	PLL_PERIPH0 Bias Register
PLL_GPU_BIAS_REG	0x023C	PLL_GPU Bias Register
PLL_PERIPH1_BIAS_REG	0x0244	PLL_PERIPH1 Bias Register
PLL_DE_BIAS_REG	0x0248	PLL_DE Bias Register
PLL_CPUX_TUN_REG	0x0250	PLL_CPUX Tuning Register
PLL_DDR_TUN_REG	0x0260	PLL_DDR Tuning Register
PLL_CPUX_PAT_CTRL_REG	0x0280	PLL_CPUX Pattern Control Register
PLL_AUDIO_PAT_CTRL_REG0	0x0284	PLL_AUDIO Pattern Control Register
PLL_VIDEO_PAT_CTRL_REG0	0x0288	PLL_VIDEO Pattern Control Register
PLL_VE_PAT_CTRL_REG	0x028C	PLL_VE Pattern Control Register
PLL_DDR_PAT_CTRL_REG0	0x0290	PLL_DDR Pattern Control Register
PLL_GPU_PAT_CTRL_REG	0x029C	PLL_GPU Pattern Control Register
PLL_PERIPH1_PAT_CTRL_REG1	0x02A4	PLL_PERIPH1 Pattern Control Register
PLL_DE_PAT_CTRL_REG	0x02A8	PLL_DE Pattern Control Register
BUS_SOFT_RST_REG0	0x02C0	Bus Software Reset Register 0
BUS_SOFT_RST_REG1	0x02C4	Bus Software Reset Register 1
BUS_SOFT_RST_REG2	0x02C8	Bus Software Reset Register 2
BUS_SOFT_RST_REG3	0x02D0	Bus Software Reset Register 3
BUS_SOFT_RST_REG4	0x02D8	Bus Software Reset Register 4
CCU_SEC_SWITCH_REG	0x02F0	CCU Security Switch Register
PS_CTRL_REG	0x0300	PS Control Register
PS_CNT_REG	0x0304	PS Counter Register

### 4.3.5. Register Description

#### 4.3.5.1. PLL\_CPUX Control Register (Default Value: 0x00001000)

Offset: 0x0000			Register Name: PLL_CPUX_CTRL_REG
Bit	R/W	Default/Hex	Description
31	R/W	0x0	PLL_ENABLE. 0: Disable 1: Enable The PLL Output= (24MHz*N*K)/(M*P). The PLL output is for the CPUX Clock. Note: The PLL output clock must be in the range of 200MHz~2.6GHz. Its default is 408MHz.
30:29	/	/	/
28	R	0x0	LOCK 0: Unlocked 1: Locked (It indicates that the PLL has been stable.)
27:25	/	/	/
24	R/W	0x0	CPUX_SDM_EN. 0: Disable 1: Enable
23:18	/	/	/
17:16	R/W	0x0	PLL_OUT_EXT_DIVP PLL Output external divider P 00: /1 01: /2 10: /4 11: / Note:The P factor only use in the condition that PLL output less than 288 MHz.
15:13	/	/	/
12:8	R/W	0x10	PLL_FACTOR_N PLL Factor N. Factor=0, N=1 Factor=1, N=2 Factor=2, N=3 ..... Factor=31, N=32
7:6	/	/	/
5:4	R/W	0x0	PLL_FACTOR_K. PLL Factor K.(K=Factor + 1 ) The range is from 1 to 4.
3:2	/	/	/
1:0	R/W	0x0	PLL_FACTOR_M.

			PLL Factor M. (M=Factor + 1) The range is from 1 to 4.
--	--	--	---

**4.3.5.2. PLL\_Audio Control Register (Default Value: 0x00035514)**

Offset: 0x0008			Register Name: PLL_AUDIO_CTRL_REG
Bit	R/W	Default/Hex	Description
31	R/W	0x0	PLL_ENABLE. 0: Disable 1: Enable. The PLL is for Audio. $PLL\_AUDIO = (24MHz * N) / (M * P)$ $PLL\_AUDIO(8X) = (24MHz * N * 2) / M$ $PLL\_AUDIO(4X) = PLL\_AUDIO(8X) / 2$ $PLL\_AUDIO(2X) = PLL\_AUDIO(4X) / 2$ The PLL output clock must be in the range of 20MHz~200MHz. Its default is 24.571MHz.
30:29	/	/	/
28	R	0x0	LOCK. 0: Unlocked 1: Locked (It indicates that the PLL has been stable.)
27:25	/	/	/
24	R/W	0x0	PLL_SDM_EN. 0: Disable 1: Enable In this case, the PLL_FACTOR_N only low 4 bits are valid (N: The range is from 1 to 16).
23:20	/	/	/
19:16	R/W	0x3	PLL_POSTDIV_P. Post-div factor (P= Factor+1) The range is from 1 to 16.
15	/	/	/
14:8	R/W	0x55	PLL_FACTOR_N. PLL Factor N. Factor=0, N=1 Factor=1, N=2 ..... Factor=127, N=128
7:5	/	/	/
4:0	R/W	0x14	PLL_PREDIV_M. PLL Pre-div Factor(M = Factor+1). The range is from 1 to 32.

**4.3.5.3. PLL\_VIDEO Control Register (Default Value: 0x03006207)**

Offset: 0x0010			Register Name: <b>PLL_VIDEO_CTRL_REG</b>
Bit	R/W	Default/Hex	Description
31	R/W	0x0	<b>PLL_ENABLE.</b> 0: Disable 1: Enable In the integer mode,the PLL Output = (24MHz*N)/M. In the fractional mode, the PLL Output is select by bit 25. Note: In the Clock Control Module, PLL(1X) Output=PLL while PLL(2X) Output=PLL * 2. The PLL output clock must be in the range of 30MHz~600MHz. Its default is 297MHz.
30	R/W	0x0	<b>PLL_MODE.</b> 0: Manual Mode 1: Auto Mode (Controlled by DE)
29	/	/	/
28	R	0x0	<b>LOCK.</b> 0: Unlocked 1: Locked (It indicates that the PLL has been stable.)
27:26	/	/	/
25	R/W	0x1	<b>FRAC_CLK_OUT.</b> PLL clock output when PLL_MODE_SEL=0(PLL_PREDIV_M factor must be set to 0); No meaning when PLL_MODE_SEL =1. 0: PLL Output=270MHz 1: PLL Output =297MHz
24	R/W	0x1	<b>PLL_MODE_SEL.</b> 0: Fractional Mode 1: Integer Mode Note: When in Fractional mode, the Per Divider M should be set to 0.
23:21	/	/	/
20	R/W	0x0	<b>PLL_SDM_EN.</b> 0: Disable 1: Enable
19:15	/	/	/
14:8	R/W	0x62	<b>PLL_FACTOR_N.</b> PLL Factor N. Factor=0, N=1 Factor=1, N=2 Factor=2, N=3 ..... Factor=127, N=128
7:4	/	/	/
3:0	R/W	0x7	<b>PLL_PREDIV_M.</b> PLL Pre-div Factor(M = Factor+1).

			The range is from 1 to 16.
--	--	--	----------------------------

**4.3.5.4. PLL\_VE Control Register (Default Value: 0x03006207)**

Offset: 0x0018			Register Name: <b>PLL_VE_CTRL_REG</b>
Bit	R/W	Default/Hex	Description
31	R/W	0x0	PLL_ENABLE. 0: Disable 1: Enable In the integer mode, The PLL Output = (24MHz*N)/M. In the fractional mode, the PLL Output is select by bit 25. Note: The PLL output clock must be in the range of 30MHz~600MHz. Its default is 297MHz.
30:29	/	/	/
28	R	0x0	LOCK 0: Unlocked 1: Locked (It indicates that the PLL has been stable.)
27:26	/	/	/
25	R/W	0x1	FRAC_CLK_OUT. PLL clock output when PLL_MODE_SEL=0(PLL_PREDIV_M factor must be set to 0); No meaning when PLL_MODE_SEL =1. 0: PLL Output=270MHz 1: PLL Output =297MHz
24	R/W	0x1	PLL_MODE_SEL. 0: Fractional Mode 1: Integer Mode Note: When in Fractional mode, the Per Divider M should be set to 0.
23:21	/	/	/
20	R/W	0x0	PLL_SDM_EN. 0: Disable 1: Enable
19:15	/	/	/
14:8	R/W	0x62	PLL_FACTOR_N. PLL Factor N. Factor=0, N=1 Factor=1, N=2 Factor=2, N=3 ..... Factor=31, N=32 ... Factor=127, N=128
7:4	/	/	/
3:0	R/W	0x7	PLL_PREDIV_M. PLL Pre Divider (M = Factor+1).

			The range is from 1 to 16.
--	--	--	----------------------------

**4.3.5.5. PLL\_DDR Control Register (Default Value: 0x00001000)**

Offset: 0x0020			Register Name: <b>PLL_DDR_CTRL_REG</b>
Bit	R/W	Default/Hex	Description
31	R/W	0x0	PLL_ENABLE. 0: Disable 1: Enable Set bit20 to validate the PLL after this bit is set to 1. The PLL Output = (24MHz*N*K)/M. Note: the PLL output clock must be in the range of 200MHz~2.6GHz. Its default is 408MHz.
30:29	/	/	/
28	R	0x0	LOCK 0: Unlocked 1: Locked (It indicates that the PLL has been stable.)
27:25	/	/	/
24	R/W	0x0	PLL_SDM_EN. 0: Disable 1: Enable
23:21	/	/	/
20	R/W	0x0	PLL_DDR_CFG_UPDATE. PLL_DDR Configuration Update. When PLL_DDR has been changed, this bit should be set to 1 to validate the PLL, otherwise the change would be invalid. And this bit would be cleared automatically after the PLL change is valid. 0: No effect 1: Validating the PLL_DDR
19:13	/	/	/
12:8	R/W	0x10	PLL_FACTOR_N. PLL Factor N. Factor=0, N=1 Factor=1, N=2 Factor=2, N=3 ..... Factor=31, N=32
7:6	/	/	/
5:4	R/W	0x0	PLL_FACTOR_K. PLL Factor K.(K=Factor + 1) The range is from 1 to 4.
3:2	/	/	/
1:0	R/W	0x0	PLL_FACTOR_M. PLL Factor M.(M = Factor + 1)



			The range is from 1 to 4.
--	--	--	---------------------------

**4.3.5.6. PLL\_PERIPH0 Control Register (Default Value: 0x00041811)**

Offset: 0x0028			Register Name: PLL_PERIPH0_CTRL_REG
Bit	R/W	Default/Hex	Description
31	R/W	0x0	PLL_ENABLE. 0: Disable 1: Enable The PLL Output = 24MHz*N*K/2. Note: The PLL Output should be fixed to 600MHz, it is not recommended to vary this value arbitrarily. In the Clock Control Module, PLL(2X) output= PLL*2 = 24MHz*N*K. The PLL output clock must be in the range of 200MHz~1.8GHz. Its default is 600MHz.
30:29	/	/	/
28	R	0x0	LOCK. 0: Unlocked 1: Locked (It indicates that the PLL has been stable.)
27:26	/	/	/
25	R/W	0x0	PLL_BYPASS_EN. PLL Output Bypass Enable. 0: Disable 1: Enable If the bypass is enabled, the PLL output is 24MHz.
24	R/W	0x0	PLL_CLK_OUT_EN. PLL clock output enable. 0: Disable 1: Enable
23:19	/	/	/
18	R/W	0x1	PLL_24M_OUT_EN. PLL 24MHz Output Enable. 0: Disable 1: Enable When 25MHz crystal used, this PLL can output 24MHz.
17:16	R/W	0x0	PLL_24M_POST_DIV. PLL 24M Output Clock Post Divider (When 25MHz crystal used). 1/2/3/4.
15:13	/	/	/
12:8	R/W	0x18	PLL_FACTOR_N. PLL Factor N. Factor=0, N=1 Factor=1, N=2 Factor=2, N=3

			..... Factor=31, N=32
7:6	/	/	/
5:4	R/W	0x1	PLL_FACTOR_K. PLL Factor K.(K=Factor + 1 ) The range is from 1 to 4.
3:2	/	/	/
1:0	R/W	0x1	PLL_FACTOR_M. PLL Factor M (M = Factor + 1) is only valid in plltest debug. The PLL_PERIPH back door clock output =24MHz*N*K/M. The range is from 1 to 4.

#### 4.3.5.7. PLL\_GPU Control Register (Default Value: 0x03006207)

Offset: 0x0038			Register Name: PLL_GPU_CTRL_REG
Bit	R/W	Default/Hex	Description
31	R/W	0x0	PLL_ENABLE. 0: Disable 1: Enable In the integer mode, The PLL_GPU Output=( 24MHz*N)/M. In the fractional mode, the PLL_GPU Output is select by bit 25. Note: The PLL output clock must be in the range of 30MHz~600MHz. Its default is 297MHz.
30:29	/	/	/
28	R	0x0	LOCK. 0: Unlocked 1: Locked (It indicates that the PLL has been stable.)
27:26	/	/	/
25	R/W	0x1	FRAC_CLK_OUT. PLL clock output when PLL_MODE_SEL=0(PLL_PREDIV_M factor must be set to 0); no meaning when PLL_MODE_SEL =1. 0: PLL Output=270MHz 1: PLL Output=297MHz
24	R/W	0x1	PLL_MODE_SEL. 0: Fractional Mode. 1: Integer Mode Note: When in Fractional mode, the Per Divider M should be set to 0.
23:21	/	/	/
20	R/W	0x0	PLL_SDM_EN. 0: Disable 1: Enable
19:15	/	/	/
14:8	R/W	0x62	PLL_FACTOR_N PLL Factor N.

			Factor=0, N=1 Factor=1, N=2 Factor=2, N=3 ..... Factor=127, N=128
7:4	/	/	/
3:0	R/W	0x7	PLL_PRE_DIV_M. PLL Pre Divider (M = Factor+1). The range is from 1 to 16.

#### 4.3.5.8. PLL\_PERIPH1 Control Register (Default Value: 0x00041811)

Offset: 0x0044			Register Name: PLL_PERIPH1_CTRL_REG
Bit	R/W	Default/Hex	Description
31	R/W	0x0	PLL_ENABLE. 0: Disable 1: Enable The PLL Output = 24MHz*N*K/2. Note: The PLL Output should be fixed to 600MHz, it is not recommended to vary this value arbitrarily. In the Clock Control Module, PLL(2X) output= PLL*2 = 24MHz*N*K. The PLL output clock must be in the range of 200MHz~1.8GHz. Its default is 600MHz.
30:29	/	/	/
28	R	0x0	LOCK. 0: Unlocked 1: Locked (It indicates that the PLL has been stable.)
27:26	/	/	/
25	R/W	0x0	PLL_BYPASS_EN. PLL Output Bypass Enable. 0: Disable 1: Enable If the bypass is enabled, the PLL output is 24MHz.
24	R/W	0x0	PLL_CLK_OUT_EN. PLL clock output enable. 0: Disable 1: Enable
23:21	/	/	/
20	R/W	0x0	PLL_SDM_EN. 0: Disable 1: Enable
19	/	/	/
18	R/W	0x1	PLL_24M_OUT_EN. PLL 24MHz Output Enable.

			0: Disable 1: Enable When 25MHz crystal used, this PLL can output 24MHz.
17:16	R/W	0x0	PLL_24M_POST_DIV. PLL 24M Output Clock Post Divider (When 25MHz crystal used). 1/2/3/4.
15:13	/	/	/
12:8	R/W	0x18	PLL_FACTOR_N. PLL Factor N. Factor=0, N=1 Factor=1, N=2 Factor=2, N=3 ..... Factor=31, N=32
7:6	/	/	/
5:4	R/W	0x1	PLL_FACTOR_K. PLL Factor K.(K=Factor + 1 ) The range is from 1 to 4.
3:2	/	/	/
1:0	R/W	0x1	PLL_FACTOR_M. PLL Factor M (M = Factor + 1) is only valid in plltest debug. The PLL_PERIPH back door clock output =24MHz*N*K/M. The range is from 1 to 4.

#### 4.3.5.9. PLL\_DE Control Register (Default Value: 0x03006207)

Offset: 0x0048			Register Name: PLL_DE_CTRL_REG
Bit	R/W	Default/Hex	Description
31	R/W	0x0	PLL_ENABLE. 0: Disable 1: Enable In the integer mode, The PLL Output= (24MHz*N)/M. In the fractional mode, the PLL Output is select by bit 25. Its default is 297MHz.
30:29	/	/	/
28	R	0x0	LOCK 0: Unlocked 1: Locked (It indicates that the PLL has been stable.)
27:26	/	/	/
25	R/W	0x1	FRAC_CLK_OUT. PLL clock output when PLL_MODE_SEL=0(PLL_PREDIV_M factor must be set to 0); no meaning when PLL_MODE_SEL =1. 0: PLL Output=270MHz 1: PLL Output =297MHz

24	R/W	0x1	PLL_MODE_SEL. 0: Fractional Mode 1: Integer Mode Note: When in Fractional mode, the Pre Divider M should be set to 0.
23:21	/	/	/
20	R/W	0x0	PLL_SDM_EN. 0: Disable 1: Enable
19:15	/	/	/
14:8	R/W	0x62	PLL_FACTOR_N PLL Factor N. Factor=0, N=1 Factor=1, N=2 Factor=2, N=3 ..... Factor=0x7F, N=128
7:4	/	/	/
3:0	R/W	0x7	PLL_PRE_DIV_M. PLL Per Divider (M = Factor+1). The range is from 1 to 16.

#### 4.3.5.10. CPUX/AXI Configuration Register (Default Value: 0x00010000)

Offset: 0x0050			Register Name: CPUX_AXI_CFG_REG
Bit	R/W	Default/Hex	Description
31:18	/	/	/
17:16	R/W	0x1	CPUX_CLK_SRC_SEL. CPUX Clock Source Select. CPUX Clock = Clock Source 00: LOSC 01: OSC24M 1X: PLL_CPUX If the clock source is changed, at most to wait for 8 present running clock cycles.
15:10	/	/	/
9:8	R/W	0x0	CPU_APB_CLK_DIV. 00: /1 01: /2 1x: /4 Note: System APB clock source is CPU clock source.
7:2	/	/	/
1:0	R/W	0x0	AXI_CLK_DIV_RATIO. AXI Clock Divide Ratio. AXI Clock source is CPU clock source.

			00: /1 01: /2 10: /3 11: /4
--	--	--	--------------------------------------

**4.3.5.11. AHB1/APB1 Configuration Register (Default Value: 0x00001010)**

Offset: 0x0054			Register Name: <b>AHB1_APB1_CFG_REG</b>
Bit	R/W	Default/Hex	Description
31:14	/	/	/
13:12	R/W	0x1	AHB1_CLK_SRC_SEL. 00: LOSC 01: OSC24M 10: AXI 11: PLL_PERIPH0/ AHB1_PRE_DIV
11:10	/	/	/
9:8	R/W	0x0	APB1_CLK_RATIO. APB1 Clock Divide Ratio. APB1 clock source is AHB1 clock. 00: /2 01: /2 10: /4 11: /8
7:6	R/W	0x0	AHB1_PRE_DIV AHB1 Clock Pre Divide Ratio 00: /1 01: /2 10: /3 11: /4
5:4	R/W	0x1	AHB1_CLK_DIV_RATIO. AHB1 Clock Divide Ratio. 00: /1 01: /2 10: /4 11: /8
3:0	/	/	/

**4.3.5.12. APB2 Configuration Register (Default Value: 0x01000000)**

Offset: 0x0058			Register Name: <b>APB2_CFG_REG</b>
Bit	R/W	Default/Hex	Description
31:26	/	/	/
25:24	R/W	0x1	APB2_CLK_SRC_SEL.

			APB2 Clock Source Select 00: LOSC 01: OSC24M 1X: PLL_PERIPH0 This clock is used for some special module apbclk(UART、TWI). Because these modules need special clock rate even if the apb1clk changed.
23:18	/	/	/
17:16	R/W	0x0	CLK_RAT_N Clock Pre Divide Ratio (n) The select clock source is pre-divided by 2^n. The divider is 1/2/4/8.
15:5	/	/	/
4:0	R/W	0x0	CLK_RAT_M. Clock Divide Ratio (m) The Pre Divide clock is divided by (m+1). The divider M is from 1 to 32.

#### 4.3.5.13. AHB2 Configuration Register (Default Value: 0x00000000)

Offset: 0x005C			Register Name: <b>AHB2_CFG_REG</b>
Bit	R/W	Default/Hex	Description
31:2	/	/	/
1:0	R/W	0x0	AHB2_CLK_CFG. 00: AHB1 Clock 01: PLL_PERIPH0 / 2 1X: / EMAC ,USBHCI1/2/3 default clock source is AHB2 Clock.

#### 4.3.5.14. Bus Clock Gating Register0 (Default Value: 0x00000000)

Offset: 0x0060			Register Name: <b>BUS_CLK_GATING_REG0</b>
Bit	R/W	Default/Hex	Description
31	R/W	0x0	USBOHCI3_GATING. Gating Clock for USB OHCI3 0: Mask 1: Pass
30	R/W	0x0	USBOHCI2_GATING. Gating Clock for USB OHCI2 0: Mask 1: Pass
29	R/W	0x0	USBOHCI1_GATING. Gating Clock for USB OHCI1 0: Mask 1: Pass

28	R/W	0x0	USB_OTG_OHCI0_GATING. Gating Clock for USB_OTG_OHCI0 0: Mask 1: Pass
27	R/W	0x0	USB_EHCI3_GATING. Gating Clock For USB EHCI3 0: Mask 1: Pass
26	R/W	0x0	USB_EHCI2_GATING. Gating Clock For USB EHCI2 0: Mask 1: Pass
25	R/W	0x0	USB_EHCI1_GATING. Gating Clock For USB EHCI1 0: Mask 1: Pass
24	R/W	0x0	USB_OTG_EHCI0_GATING. Gating Clock For USB_OTG_EHCI0 0: Mask 1: Pass
23	R/W	0x0	USB_OTG_Device_GATING. Gating Clock For USB_OTG_Device 0: Mask 1: Pass
22	/	/	/
21	R/W	0x0	SPI1_GATING. Gating Clock For SPI1 0: Mask 1: Pass
20	R/W	0x0	SPIO_GATING. Gating Clock For SPIO 0: Mask 1: Pass
19	R/W	0x0	HSTMR_GATING. Gating Clock For High Speed Timer 0: Mask 1: Pass
18	R/W	0x0	TS_GATING. Gating Clock For TS 0: Mask 1: Pass
17	R/W	0x0	EMAC_GATING. Gating Clock For EMAC 0: Mask 1: Pass



16:15	/	/	/
14	R/W	0x0	DRAM_GATING. Gating Clock For DRAM 0: Mask 1: Pass
13	R/W	0x0	NAND_GATING. Gating Clock For NAND 0: Mask 1: Pass
12:11	/	/	/
10	R/W	0x0	MMC2_GATING. Gating Clock For MMC2 0: Mask 1: Pass
9	R/W	0x0	MMC1_GATING. Gating Clock For MMC1 0: Mask 1: Pass
8	R/W	0x0	MMC0_GATING. Gating Clock For MMC0 0: Mask 1: Pass
7	/	/	/
6	R/W	0x0	DMA_GATING. Gating Clock For DMA 0: Mask 1: Pass
5	R/W	0x0	CE_GATING. Gating Clock For CE. 0: Mask 1: Pass
4:0	/	/	/

**4.3.5.15. Bus Clock Gating Register1 (Default Value: 0x00000000)**

Offset: 0x0064			Register Name: <b>BUS_CLK_GATING_REG1</b>
Bit	R/W	Default/Hex	Description
31:23	/	/	/
22	R/W	0x0	SPINLOCK_GATING. 0: Mask 1: Pass.
21	R/W	0x0	MSGBOX_GATING. 0: Mask 1: Pass.

20	R/W	0x0	GPU_GATING. 0: Mask 1: Pass.
19:13	/	/	/
12	R/W	0x0	DE_GATING. 0: Mask 1: Pass.
11	R/W	0x0	HDMI_GATING. 0: Mask 1: Pass.
10	/	/	/
9	R/W	0x0	TVE_GATING. Gating Clock For TVE 0: Mask 1: Pass.
8	R/W	0x0	CSI_GATING. 0: Mask 1: Pass.
7:6	/	/	/
5	R/W	0x0	DEINTERLACE_GATING. Gating Clock For DEINTERLACE 0: Mask 1: Pass
4	R/W	0x0	TCON1_GATING. Gating Clock For TCON1 0: Mask 1: Pass.
3	R/W	0x0	TCON0_GATING. Gating Clock For TCON0 0: Mask 1: Pass.
3:1	/	/	/
0	R/W	0x0	VE_GATING. Gating Clock For VE 0: Mask 1: Pass.

#### 4.3.5.16. Bus Clock Gating Register2 (Default Value: 0x00000000)

Offset: 0x0068			Register Name: <b>BUS_CLK_GATING_REG2</b>
Bit	R/W	Default/Hex	Description
31:15	/	/	/
14	R/W	0x0	I2S/PCM 2_GATING. Gating Clock For I2S/PCM 2

			0: Mask 1: Pass.
13	R/W	0x0	I2S/PCM 1_GATING. Gating Clock For I2S/PCM 1 0: Mask 1: Pass.
12	R/W	0x0	I2S/PCM 0_GATING. Gating Clock For I2S/PCM 0 0: Mask 1: Pass.
11:9	/	/	/
8	R/W	0x0	THS_GATING. Gating Clock For THS 0: Mask 1: Pass
7:6	/	/	/
5	R/W	0x0	PIO_GATING. Gating Clock For PIO 0: Mask 1: Pass.
4:2	/	/	/
1	R/W	0x0	OWA_GATING. Gating Clock For OWA 0: Mask 1: Pass.
0	R/W	0x0	AC_DIG_GATING. Gating Clock For AC Digital 0: Mask 1: Pass

#### 4.3.5.17. Bus Clock Gating Register3 (Default Value: 0x00000000)

Offset: 0x006C			Register Name: <b>BUS_CLK_GATING_REG3</b>
Bit	R/W	Default/Hex	Description
31:21	/	/	/
20	R/W	0x0	SCR_GATING. Gating Clock For SCR 0: Mask 1: Pass
19	R/W	0x0	UART3_GATING. Gating Clock For UART3 0: Mask 1: Pass.
18	R/W	0x0	UART2_GATING.

			Gating Clock For UART2 0: Mask 1: Pass.
17	R/W	0x0	UART1_GATING. Gating Clock For UART1 0: Mask 1: Pass.
16	R/W	0x0	UART0_GATING. Gating Clock For UART0 0: Mask 1: Pass.
15:3	/	/	/
2	R/W	0x0	TWI2_GATING. Gating Clock For TWI2 0: Mask 1: Pass.
1	R/W	0x0	TWI1_GATING. Gating Clock For TWI1 0: Mask 1: Pass.
0	R/W	0x0	TWI0_GATING. Gating Clock For TWI0 0: Mask 1: Pass.

#### 4.3.5.18. Bus Clock Gating Register4 (Default Value: 0x00000000)

Offset: 0x0070			Register Name: <b>BUS_CLK_GATING_REG4</b>
Bit	R/W	Default/Hex	Description
31:8	/	/	/
7	R/W	0x0	DBGSYS_GATING. Gating Clock For DBGSYS 0: Mask 1: Pass
6:1	/	/	/
0	R/W	0x0	EPHY_GATING. Gating Clock For EPHY 0: Mask 1: Pass

**4.3.5.19. THS Clock Register (Default Value: 0x00000000)**

Offset: 0x0074			Register Name: <b>THS_CLK_REG</b>
Bit	R/W	Default/Hex	Description
31	R/W	0x0	SCLK_GATING. Gating Special Clock. 0: Clock is OFF 1: Clock is ON This special clock = Clock Source/CLK_DIV_RATIO.
30:26	/	/	/
25:24	R/W	0x0	THS_CLK_SRC_SEL. Clock Source Select 00: OSC24M 01: / 10: / 11: /
23:2	/	/	/
1:0	R/W	0x0	THS_CLK_DIV_RATIO. THS clock divide ratio. 00: /1 01: /2 10: /4 11: /6

**4.3.5.20. NAND Clock Register (Default Value: 0x00000000)**

Offset: 0x0080			Register Name: <b>NAND_CLK_REG</b>
Bit	R/W	Default/Hex	Description
31	R/W	0x0	SCLK_GATING. Gating Special Clock(Max Clock = 200MHz) 0: Clock is OFF 1: Clock is ON. SCLK = Clock Source/Divider N/Divider M.
30:26	/	/	/
25:24	R/W	0x0	CLK_SRC_SEL. Clock Source Select 00: OSC24M 01: PLL_PERIPH0 10: PLL_PERIPH1 11: /
23:18	/	/	/
17:16	R/W	0x0	CLK_DIV_RATIO_N. Clock Pre Divide Ratio (n)

			00: /1 01: /2 10: /4 11: /8.
15:4	/	/	/
3:0	R/W	0x0	CLK_DIV_RATIO_M Clock Divide Ratio (m) The pre-divided clock is divided by (m+1). The divider M is from 1 to 16.

#### 4.3.5.21. SDMMC0 Clock Register (Default Value: 0x00000000)

Offset: 0x0088			Register Name: <b>SDMMC0_CLK_REG</b>
Bit	R/W	Default/Hex	Description
31	R/W	0x0	SCLK_GATING. Gating Special Clock(Max Clock = 200MHz) 0: Clock is OFF 1: Clock is ON. SCLK = Clock Source/Divider N/Divider M.
30:26	/	/	/
25:24	R/W	0x0	CLK_SRC_SEL. Clock Source Select 00: OSC24M 01: PLL_PERIPH0 10: PLL_PERIPH1 11: /
23	/	/	/
22:20	R/W	0x0	SAMPLE_CLK_PHASE_CTR. Sample Clock Phase Control. The sample clock phase delay is based on the number of source clock that is from 0 to 7.
19:18	/	/	/
17:16	R/W	0x0	CLK_DIV_RATIO_N. Clock Pre Divide Ratio (n) 00: /1 01: /2 10: /4 11: /8.
15:11	/	/	/
10:8	R/W	0x0	OUTPUT_CLK_PHASE_CTR. Output Clock Phase Control. The output clock phase delay is based on the number of source clock that is from 0 to 7.
7:4	/	/	/
3:0	R/W	0x0	CLK_DIV_RATIO_M.

			Clock Divide Ratio (m) The pre-divided clock is divided by (m+1). The divider M is from 1 to 16.
--	--	--	---

**4.3.5.22. SDMMC1 Clock Register (Default Value: 0x00000000)**

Offset: 0x008C			Register Name: <b>SDMMC1_CLK_REG</b>
Bit	R/W	Default/Hex	Description
31	R/W	0x0	SCLK_GATING. Gating Special Clock(Max Clock = 200MHz) 0: Clock is OFF 1: Clock is ON. If SDMMC1 is in old mode, SCLK = Clock Source/Divider N/Divider M. If SDMMC1 is in new mode, SCLK= Clock Source/Divider N/Divider M/2.
30	R/W	0x0	MMC1_MODE_SELECT. 0: Old Mode 1: New Mode.
29:26	/	/	/
25:24	R/W	0x0	CLK_SRC_SEL. Clock Source Select 00: OSC24M 01: PLL_PERIPH0 10: PLL_PERIPH1 11: /
23	/	/	/
22:20	R/W	0x0	SAMPLE_CLK_PHASE_CTR. Sample Clock Phase Control. The sample clock phase delay is based on the number of source clock that is from 0 to 7.
19:18	/	/	/
17:16	R/W	0x0	CLK_DIV_RATIO_N. Clock Pre-Divide Ratio (n) 00: /1 01: /2 10: /4 11: /8.
15:11	/	/	/
10:8	R/W	0x0	OUTPUT_CLK_PHASE_CTR. Output Clock Phase Control. The output clock phase delay is based on the number of source clock that is from 0 to 7.
7:4	/	/	/
3:0	R/W	0x0	CLK_DIV_RATIO_M. Clock Divide Ratio (m) The pre-divided clock is divided by (m+1). The divider M is from 1 to 16.

**4.3.5.23. SDMMC2 Clock Register (Default Value: 0x00000000)**

Offset: 0x0090			Register Name: <b>SDMMC2_CLK_REG</b>
Bit	R/W	Default/Hex	Description
31	R/W	0x0	SCLK_GATING. Gating Special Clock(Max Clock = 200MHz) 0: Clock is OFF 1: Clock is ON. If SDMMC2 is in old mode, SCLK = Clock Source/Divider N/Divider M. If SDMMC2 is in new mode, SCLK= Clock Source/Divider N/Divider M/2.
30	R/W	0x0	MMC2_MODE_SELECT. 0: Old Mode 1: New Mode.
29:26	/	/	/
25:24	R/W	0x0	CLK_SRC_SEL. Clock Source Select 00: OSC24M 01: PLL_PERIPH0 10: PLL_PERIPH1 11: /
23	/	/	/
22:20	R/W	0x0	CLK_PHASE_CTR. Sample Clock Phase Control. The sample clock phase delay is based on the number of source clock that is from 0 to 7.
19:18	/	/	/
17:16	R/W	0x0	CLK_DIV_RATIO_N. Clock Pre Divide Ratio (n) 00: /1 01: /2 10: /4 11: /8.
15:11	/	/	/
10:8	R/W	0x0	OUTPUT_CLK_PHASE_CTR. Output Clock Phase Control. The output clock phase delay is based on the number of source clock that is from 0 to 7.
7:4	/	/	/
3:0	R/W	0x0	CLK_DIV_RATIO_M. Clock Divide Ratio (m) The pre-divided clock is divided by (m+1). The divider M is from 1 to 16.



**4.3.5.24. TS Clock Register (Default Value: 0x00000000)**

Offset: 0x0098			Register Name: <b>TS_CLK_REG</b>
Bit	R/W	Default/Hex	Description
31	R/W	0x0	SCLK_GATING. Gating Special Clock(Max Clock = 200MHz) 0: Clock is OFF 1: Clock is ON. SCLK = Clock Source/Divider N/Divider M.
30:28	/	/	/
27:24	R/W	0x0	CLK_SRC_SEL. Clock Source Select 0000: OSC24M 0001: PLL_PERIPH0 Others: /
23:18	/	/	/
17:16	R/W	0x0	CLK_DIV_RATIO_N. Clock pre-divide ratio (n) The select clock source is pre-divided by 2 <sup>n</sup> . The divider is 1/2/4/8.
15:4	/	/	/
3:0	R/W	0x0	CLK_DIV_RATIO_M. Clock divide ratio (m) The pre-divided clock is divided by (m+1). The divider is from 1 to 16.

**4.3.5.25. CE Clock Register (Default Value: 0x00000000)**

Offset: 0x009C			Register Name: <b>CE_CLK_REG</b>
Bit	R/W	Default/Hex	Description
31	R/W	0x0	SCLK_GATING. Gating Special Clock(Max Clock = 400MHz) 0: Clock is OFF 1: Clock is ON. SCLK = Clock Source/Divider N/Divider M.
30:26	/	/	/
25:24	R/W	0x0	CLK_SRC_SEL. Clock Source Select 00: OSC24M 01: PLL_PERIPH0 10: PLL_PERIPH1 11: /
23:18	/	/	/
17:16	R/W	0x0	CLK_DIV_RATIO_N. Clock Pre Divide Ratio (n)

			00: /1 01: /2 10: /4 11: /8.
15:4	/	/	/
3:0	R/W	0x0	CLK_DIV_RATIO_M. Clock divide ratio (m) The pre-divided clock is divided by (m+1). The divider M is from 1 to 16.

#### 4.3.5.26. SPI0 Clock Register (Default Value: 0x00000000)

Offset: 0x00A0			Register Name: <b>SPI0_CLK_REG</b>
Bit	R/W	Default/Hex	Description
31	R/W	0x0	SCLK_GATING. Gating Special Clock(Max Clock = 200MHz) 0: Clock is OFF 1: Clock is ON. SCLK = Clock Source/Divider N/Divider M.
30:26	/	/	/
25:24	R/W	0x0	CLK_SRC_SEL. Clock Source Select 00: OSC24M 01: PLL_PERIPH0 10: PLL_PERIPH1 11: /
23:18	/	/	/
17:16	R/W	0x0	CLK_DIV_RATIO_N. Clock Pre Divide Ratio (n) 00: /1 01: /2 10: /4 11: /8.
15:4	/	/	/
3:0	R/W	0x0	CLK_DIV_RATIO_M. Clock Divide Ratio (m) The pre-divided clock is divided by (m+1). The divider M is from 1 to 16.

#### 4.3.5.27. SPI1 Clock Register (Default Value: 0x00000000)

Offset: 0x00A4			Register Name: <b>SPI1_CLK_REG</b>
Bit	R/W	Default/Hex	Description
31	R/W	0x0	SCLK_GATING.

			Gating Special Clock(Max Clock = 200MHz) 0: Clock is OFF 1: Clock is ON. SCLK= Clock Source/Divider N/Divider M.
30:26	/	/	/
25:24	R/W	0x0	CLK_SRC_SEL. Clock Source Select 00: OSC24M 01: PLL_PERIPH0 10: PLL_PERIPH1 11: /
23:18	/	/	/
17:16	R/W	0x0	CLK_DIV_RATIO_N. Clock Pre Divide Ratio (n) 00: /1 01: /2 10: /4 11: /8.
15:4	/	/	/
3:0	R/W	0x0	CLK_DIV_RATIO_M. Clock Divide Ratio (m) The pre-divided clock is divided by (m+1). The divider M is from 1 to 16.

#### 4.3.5.28. I2S/PCM 0 Clock Register (Default Value: 0x00000000)

Offset: 0x00B0			Register Name: <b>I2S/PCM 0_CLK_REG</b>
Bit	R/W	Default/Hex	Description
31	R/W	0x0	SCLK_GATING. Gating Special Clock(Max Clock = 200MHz) 0: Clock is OFF 1: Clock is ON. SCLK= Clock Source PLL_AUDIO/Divider M.
30:18	/	/	/
17:16	R/W	0x0	CLK_SRC_SEL. 00: PLL_AUDIO (8X) 01: PLL_AUDIO(8X)/2 10: PLL_AUDIO(8X)/4 11: PLL_AUDIO
15:0	/	/	/

**4.3.5.29. I2S/PCM 1 Clock Register (Default Value: 0x00000000)**

Offset: 0x00B4			Register Name: <b>I2S/PCM 1_CLK_REG</b>
Bit	R/W	Default/Hex	Description
31	R/W	0x0	SCLK_GATING. Gating Special Clock(Max Clock = 200MHz) 0: Clock is OFF 1: Clock is ON.
30:18	/	/	/
17:16	R/W	0x0	CLK_SRC_SEL. 00: PLL_AUDIO (8X) 01: PLL_AUDIO(8X)/2 10: PLL_AUDIO(8X)/4 11: PLL_AUDIO
15:0	/	/	/

**4.3.5.30. I2S/PCM 2 Clock Register (Default Value: 0x00000000)**

Offset: 0x00B8			Register Name: <b>I2S/PCM 2_CLK_REG</b>
Bit	R/W	Default/Hex	Description
31	R/W	0x0	SCLK_GATING. Gating Special Clock(Max Clock = 200MHz) 0: Clock is OFF 1: Clock is ON.
30:18	/	/	/
17:16	R/W	0x0	CLK_SRC_SEL. 00: PLL_AUDIO (8X) 01: PLL_AUDIO(8X)/2 10: PLL_AUDIO(8X)/4 11: PLL_AUDIO
15:0	/	/	/

**4.3.5.31. OWA Clock Register (Default Value: 0x00000000)**

Offset: 0x00C0			Register Name: <b>OWA_CLK_REG</b>
Bit	R/W	Default/Hex	Description
31	R/W	0x0	SCLK_GATING. Gating Special Clock(Max Clock = 200MHz) 0: Clock is OFF 1: Clock is ON. SCLK= PLL_AUDIO/Divider M.
30:4	/	/	/

3:0	R/W	0x0	CLK_DIV_RATIO_M. Clock Divide Ratio (m) The pre-divided clock is divided by (m+1). The divider M is from 1 to 16.
-----	-----	-----	---

**4.3.5.32. USBPHY Configuration Register (Default Value: 0x00000000)**

Offset: 0x00CC			Register Name: <b>USBPHY_CFG_REG</b>
Bit	R/W	Default/Hex	Description
31:20	/	/	/
19	R/W	0x0	SCLK_GATING_OHCI3. Gating Special Clock For OHCI3 0: Clock is OFF 1: Clock is ON
18	R/W	0x0	SCLK_GATING_OHCI2. Gating Special Clock For OHCI2 0: Clock is OFF 1: Clock is ON
17	R/W	0x0	SCLK_GATING_OHCI1. Gating Special Clock For OHCI1 0: Clock is OFF 1: Clock is ON
16	R/W	0x0	SCLK_GATING_OTG_OHCI0. Gating Special Clock For USB OTG_OHCI0 0: Clock is OFF 1: Clock is ON
15:12	/	/	/
11	R/W	0x0	SCLK_GATING_USBPHY3. Gating Special Clock For USB PHY3 0: Clock is OFF 1: Clock is ON
10	R/W	0x0	SCLK_GATING_USBPHY2. Gating Special Clock For USB PHY2 0: Clock is OFF 1: Clock is ON
9	R/W	0x0	SCLK_GATING_USBPHY1. Gating Special Clock For USB PHY1 0: Clock is OFF 1: Clock is ON
8	R/W	0x0	SCLK_GATING_USBPHY0. Gating Special Clock For USB PHY0 0: Clock is OFF 1: Clock is ON
7:4	/	/	/
3	R/W	0x0	USBPHY3_RST.

			USB PHY3 Reset Control 0: Assert 1: De-assert
2	R/W	0x0	USBPHY2_RST. USB PHY2 Reset Control 0: Assert 1: De-assert.
1	R/W	0x0	USBPHY1_RST. USB PHY1 Reset Control 0: Assert 1: De-assert
0	R/W	0x0	USBPHY0_RST. USB PHY0 Reset Control 0: Assert 1: De-assert

#### 4.3.5.33. DRAM Configuration Register (Default Value: 0x00000000)

Offset: 0x00F4			Register Name: <b>DRAM_CFG_REG</b>
Bit	R/W	Default/Hex	Description
31	R/W	0x0	DRAM_CTR_RST. DRAM Controller Reset For AHB Clock Domain. 0: Assert 1: De-assert.
30:22			
21:20	R/W	0x0	CLK_SRC_SEL. 00: PLL_DDR 01: PLL_PERIPH0 (2X) Others: /
19:17	/	/	/
16	R/W	0x0	SDRCLK_UPD. SDRCLK Configuration Update. 0:Invalid 1:Valid. Note: Set this bit will validate Configuration . It will be auto cleared after the Configuration is valid. The DRAMCLK Source is from PLL_DDR.
15:4	/	/	/
3:0	R/W	0x0	DRAM_DIV_M. DRAMCLK Divider of Configuration. The clock is divided by (m+1). The divider M should be from 1 to 16.

**4.3.5.34. MBUS Reset Register (Default Value: 0x80000000)**

Offset: 0x00FC			Register Name: <b>MBUS_RST_REG</b>
Bit	R/W	Default/Hex	Description
31	R/W	0x1	MBUS_RESET. 0: Reset Mbus Domain 1: Assert Mbus Domain.
30:0	/	/	/

**4.3.5.35. DRAM Clock Gating Register (Default Value: 0x00000000)**

Offset: 0x0100			Register Name: <b>DRAM_CLK_GATING_REG</b>
Bit	R/W	Default/Hex	Description
31:4	/	/	/
3	R/W	0x0	TS_DCLK_GATING. Gating DRAM Clock For TS 0: Mask 1: Pass
2	R/W	0x0	DEINTERLACE_DCLK_GATING. Gating DRAM SCLK(1X) For DEINTERLACE 0: Mask 1: Pass
1	R/W	0x0	CSI_DCLK_GATING. Gating DRAM Clock For CSI 0: Mask 1: Pass
0	R/W	0x0	VE_DCLK_GATING. Gating DRAM Clock For VE 0: Mask 1: Pass

**4.3.5.36. DE Clock Gating Register (Default Value: 0x00000000)**

Offset: 0x0104			Register Name: <b>BE_CLK_REG</b>
Bit	R/W	Default/Hex	Description
31	R/W	0x0	SCLK_GATING. Gating Special Clock 0: Clock is OFF 1: Clock is ON This special clock = Clock Source/Divider M.
30:27	/	/	/
26:24	R/W	0x0	CLK_SRC_SEL.

			Clock Source Select 000: PLL_PERIPH0(2X) 001: PLL_DE Others: /
23:4	/	/	/
3:0	R/W	0x0	CLK_DIV_RATIO_M. Clock Divide Ratio (m) The pre-divided clock is divided by (m+1). The divider is from 1 to 16.

**4.3.5.37. TCON0 Clock Register (Default Value: 0x00000000)**

Offset: 0x0118			Register Name: TCON0_CLK_REG
Bit	R/W	Default/Hex	Description
31	R/W	0x0	SCLK_GATING. Gating Special Clock 0: Clock is OFF 1: Clock is ON.
30:27	/	/	/
26:24	R/W	0x0	CLK_SRC_SEL. Clock Source Select 000: PLL_VIDEO Others: /.
23:4	/	/	/
3:0	R/W	0x0	CLK_DIV_RATIO_M. Clock Divide Ratio (m) The pre-divided clock is divided by (m+1). The divider M is from 1 to 16.

**4.3.5.38. TVE Clock Register (Default Value: 0x00000000)**

Offset: 0x0120			Register Name: TVE_CLK_REG
Bit	R/W	Default/Hex	Description
31	R/W	0x0	SCLK_GATING. Gating Special Clock 0: Clock is OFF 1: Clock is ON SCLK= Clock Source/ Divider M.
30:27	/	/	/
26:24	R/W	0x0	CLK_SRC_SEL. Clock Source Select 000: PLL_DE 001: PLL_PERIPH1 Others: /



23:4	/	/	/
3:0	R/W	0x0	CLK_DIV_RATIO_M. Clock Divide Ratio (m) The pre-divided clock is divided by (m+1). The divider is from 1 to 16.

#### 4.3.5.39. DEINTERLACE Clock Register (Default Value: 0x00000000)

Offset: 0x0124			Register Name: <b>DEINTERLACE_CLK_REG</b>
Bit	R/W	Default/Hex	Description
31	R/W	0x0	SCLK_GATING. Gating Special Clock 0: Clock is OFF 1: Clock is ON SCLK = Clock Source/ Divider M
30:27	/	/	/
26:24	R/W	0x0	CLK_SRC_SEL. Clock Source Select 000: PLL_PERIPH0 001: PLL_PERIPH1 Others: /
23:4	/	/	/
3:0	R/W	0x0	CLK_DIV_RATIO_M. Clock Divide Ratio (m) The pre-divided clock is divided by (m+1). The divider is from 1 to 16.

#### 4.3.5.40. CSI\_MISC Clock Register (Default Value: 0x00000000)

Offset: 0x0130			Register Name: <b>CSI_MISC_CLK_REG</b>
Bit	R/W	Default/Hex	Description
31	R/W	0x0	MIPI_CSI_CFG. 0: Clock is OFF 1: Clock is ON. This clock = OSC24M.
30:0	/	/	/

#### 4.3.5.41. CSI Clock Register (Default Value: 0x00000000)

Offset: 0x0134			Register Name: <b>CSI_CLK_REG</b>
Bit	R/W	Default/Hex	Description
31	R/W	0x0	CSI_SCLK_GATING. Gating Special Clock

			0: Clock is OFF 1: Clock is ON. SCLK= Special Clock Source/CSI_SCLK_DIV_M.
30:27	/	/	/
26:24	R/W	0x0	SCLK_SRC_SEL. Special Clock Source Select 000: PLL_PERIPH0 001: PLL_PERIPH1 Others: /
23:20	/	/	/
19:16	R/W	0x0	CSI_SCLK_DIV_M. CSI Clock Divide Ratio (m) The pre-divided clock is divided by (m+1). The divider M is from 1 to 16.
15	R/W	0x0	CSI_MCLK_GATING. Gating Master Clock 0: Clock is OFF 1: Clock is ON This clock =Master Clock Source/ CSI_MCLK_DIV_M.
14:11	/	/	/
10:8	R/W	0x0	MCLK_SRC_SEL. Master Clock Source Select 000: OSC24M 001: PLL_VIDEO 010: PLL_PERIPH1 Others: /
7:5	/	/	/
4:0	R/W	0x0	CSI_MCLK_DIV_M. CSI Master Clock Divide Ratio (m) The pre-divided clock is divided by (m+1). The divider is from 1 to 32.

#### 4.3.5.42. VE Clock Register (Default Value: 0x00000000)

Offset: 0x013C			Register Name: <b>VE_CLK_REG</b>
Bit	R/W	Default/Hex	Description
31	R/W	0x0	VE_SCLK_GATING. Gating Special Clock 0: Clock is OFF 1: Clock is ON. SCLK = PLL_VE /Divider N.
30:19	/	/	/.
18:16	R/W	0x0	CLK_DIV_RATIO_N. Clock Pre Divide Ratio (N) The select clock source is pre-divided by n+1. The divider N is from 1 to 8.
15:0	/	/	/

**4.3.5.43. AC Digital Clock Register (Default Value: 0x00000000)**

Offset: 0x0140			Register Name: <b>AC_DIG_CLK_REG</b>
Bit	R/W	Default/Hex	Description
31	R/W	0x0	SCLK_1X_GATING. Gating Special Clock 0: Clock is OFF 1: Clock is ON SCLK = PLL_AUDIO Output.
30:0	/	/	/

**4.3.5.44. AVS Clock Register (Default Value: 0x00000000)**

Offset: 0x0144			Register Name: <b>AVS_CLK_REG</b>
Bit	R/W	Default/Hex	Description
31	R/W	0x0	SCLK_GATING. Gating Special Clock 0: Clock is OFF 1: Clock is ON. SCLK= OSC24M.
30:0	/	/	/

**4.3.5.45. HDMI Clock Register (Default Value: 0x00000000)**

Offset: 0x0150			Register Name: <b>HDMI_CLK_REG</b>
Bit	R/W	Default/Hex	Description
31	R/W	0x0	SCLK_GATING. Gating Special Clock 0: Clock is OFF 1: Clock is ON. SCLK= Clock Source/ Divider M.
30:26	/	/	/
25:24	R/W	0x0	SCLK_SEL. Special Clock Source Select 00: PLL_VIDEO Others: /
23:4	/	/	/
3:0	R/W	0x0	CLK_DIV_RATIO_M. Clock Divide Ratio (m) The pre-divided clock is divided by (m+1). The divider M is from 1 to 16.

**4.3.5.46. HDMI Slow Clock Register (Default Value: 0x00000000)**

Offset: 0x0154			Register Name: <b>HDMI_SLOW_CLK_REG</b>
Bit	R/W	Default/Hex	Description
31	R/W	0x0	HDMI_DDC_CLK_GATING. 0: Clock is OFF 1: Clock is ON. SCLK = OSC24M.
30:0	/	/	/

**4.3.5.47. MBUS Clock Register (Default Value: 0x00000000)**

Offset: 0x015C			Register Name: <b>MBUS_CLK_REG</b>
Bit	R/W	Default/Hex	Description
31	R/W	0x0	MBUS_SCLK_GATING. Gating Clock for MBUS 0: Clock is OFF 1: Clock is ON. MBUS_CLOCK = Clock Source/Divider M
30:26	/	/	/
25:24	R/W	0x0	MBUS_SCLK_SRC Clock Source Select 00: OSC24M 01: PLL_PERIPH0(2X) 10: PLL_DDR 11: /.
23:3	/	/	/
2:0	R/W	0x0	MBUS_SCLK_RATIO_M Clock Divide Ratio (m) The pre-divided clock is divided by (m+1). The divider M is from 1 to 8. Note: If the clock has been changed ,it must wait for at least 16 cycles.

**4.3.5.48. GPU Clock Register (Default Value: 0x00000000)**

Offset: 0x01A0			Register Name: <b>GPU_CLK_REG</b>
Bit	R/W	Default/Hex	Description
31	R/W	0x0	SCLK_GATING. 0: Clock is OFF 1: Clock is ON. SCLK= PLL-GPU/Divider N.

30:3	/	/	/.
2:0	R/W	0x0	CLK_DIV_RATIO_N. Clock Pre Divide Ratio (N) The select clock source is pre-divided by( n+1). The divider N is from 1 to 8.

**4.3.5.49. PLL Stable Time Register0 (Default Value: 0x000000FF)**

Offset: 0x0200			Register Name: <b>PLL_STABLE_TIME_REG0</b>
Bit	R/W	Default/Hex	Description
31:16	/	/	/
15:0	R/W	0x00FF	PLL_LOCK_TIME PLL Lock Time (Unit: us). Note: When any PLL (except PLL_CPU) is enabled or changed, the corresponding PLL lock bit will be set after the PLL STABLE Time.

**4.3.5.50. PLL Stable Time Register1 (Default Value: 0x000000FF)**

Offset: 0x0204			Register Name: <b>PLL_STABLE_TIME_REG1</b>
Bit	R/W	Default/Hex	Description
31:16	/	/	/
15:0	R/W	0x00FF	PLL_CPU_LOCK_TIME PLL_CPU Lock Time (Unit: us). Note: When PLL_CPU is enabled or changed, the PLL_CPU lock bit will be set after the PLL_CPU STABLE Time.

**4.3.5.51. PLL\_CPUX Bias Register (Default Value: 0x08100200)**

Offset: 0x0220			Register Name: <b>PLL_CPUX_BIAS_REG</b>
Bit	R/W	Default/Hex	Description
31	R/W	0x0	VCO_RST. VCO reset in.
30:29	/	/	/
28	R/W	0x0	EXG_MODE. Exchange Mode. Note: CPU PLL source will select PLL_PERIPH0 instead of PLL_CPU
27:24	R/W	0x8	PLL_VCO_BIAS_CTRL. PLL VCO Bias Control[3:0].
23:21	/	/	/
20:16	R/W	0x10	PLL_BIAS_CUR_CTRL. PLL Bias Current Control[4:0].
15:11	/	/	/

10:8	R/W	0x2	PLL_LOCK_CTRL. PLL Lock Time Control[2:0].
7:4	/	/	/
3:0	R/W	0x0	PLL_DAMP_FACT_CTRL. PLL Damping Factor Control[3:0].

**4.3.5.52. PLL\_AUDIO Bias Register (Default Value: 0x10100000)**

Offset: 0x0224			Register Name: <b>PLL_AUDIO_BIAS_REG</b>
Bit	R/W	Default/Hex	Description
31:29	/	/	/
28:24	R/W	0x10	PLL_VCO_BIAS. PLL VCO Bias Current[4:0].
23:21	/	/	/
20:16	R/W	0x10	PLL_BIAS_CUR. PLL Bias Current[4:0].
15:0	/	/	/

**4.3.5.53. PLL\_VIDEO Bias Register (Default Value: 0x10100000)**

Offset: 0x0228			Register Name: <b>PLL_VIDEO_BIAS_REG</b>
Bit	R/W	Default/Hex	Description
31:29	/	/	/
28:24	R/W	0x10	PLL_VCO_BIAS_CTRL. PLL VCO Bias Control[4:0].
23:21	/	/	/
20:16	R/W	0x10	PLL_BIAS_CTRL. PLL Bias Control[4:0].
15:3	/	/	/
2:0	R/W	0x0	PLL_DAMP_FACTOR_CTRL. PLL Damping Factor Control[2:0].

**4.3.5.54. PLL\_VE Bias Register (Default Value: 0x10100000)**

Offset: 0x022C			Register Name: <b>PLL_VE_BIAS_REG</b>
Bit	R/W	Default/Hex	Description
31:29	/	/	/
28:24	R/W	0x10	PLL_VCO_BIAS_CTRL. PLL VCO Bias Control[4:0].
23:21	/	/	/

20:16	R/W	0x10	PLL_BIAS_CTRL. PLL Bias Control[4:0].
15:3	/	/	/
2:0	R/W	0x0	PLL_DAMP_FACTOR_CTRL. PLL Damping Factor Control[2:0].

#### 4.3.5.55. PLL\_DDR Bias Register (Default Value: 0x81104000)

Offset: 0x0230			Register Name: <b>PLL_DDR_BIAS_REG</b>
Bit	R/W	Default/Hex	Description
31:28	R/W	0x8	PLL_VCO_BIAS. PLL VCO Bias[3:0].
27:26	/	/	/.
25	R/W	0x0	PLL_VCO_GAIN_CTRL_EN. PLL VCO Gain Control Enable. 0: Disable 1: Enable.
24	R/W	0x1	PLL_BANDW_CTRL. PLL Band Width Control. 0: Narrow 1: Wide.
23:21	/	/	/
20:16	R/W	0x10	PLL_BIAS_CUR_CTRL. PLL Bias Current Control.
15	/	/	/
14:12	R/W	0x4	PLL_VCO_GAIN_CTRL. PLL VCO Gain Control Bit[2:0].
11:4	/	/	/
3:0	R/W	0x0	PLL_DAMP_FACTOR_CTRL. PLL Damping Factor Control[3:0].

#### 4.3.5.56. PLL\_PERIPH0 Bias Register (Default Value: 0x10100010)

Offset: 0x0234			Register Name: <b>PLL_PERIPH0_BIAS_REG</b>
Bit	R/W	Default/Hex	Description
31:29	/	/	/
28:24	R/W	0x10	PLL_VCO_BIAS. PLL VCO Bias[4:0].
23:21	/	/	/
20:16	R/W	0x10	PLL_BIAS_CUR_CTRL. PLL Bias Current Control.
15:5	/	/	/

4	R/W	0x1	PLL_BANDW_CTRL. PLL Band Width Control. 0: Narrow 1: Wide
3:2	/	/	/
1:0	R/W	0x0	PLL_DAMP_FACTOR_CTRL. PLL Damping Factor Control[1:0].

**4.3.5.57. PLL\_GPU Bias Register (Default Value: 0x10100000)**

Offset: 0x023C			Register Name: <b>PLL_GPU_BIAS_REG</b>
Bit	R/W	Default/Hex	Description
31:29	/	/	/
28:24	R/W	0x10	PLL_VCO_BIAS_CTRL. PLL VCO Bias Control[4:0].
23:21	/	/	/
20:16	R/W	0x10	PLL_BIAS_CTRL. PLL Bias Control[4:0].
15:3	/	/	/
2:0	R/W	0x0	PLL_DAMP_FACTOR_CTRL. PLL Damping Factor Control[2:0].

**4.3.5.58. PLL\_PERIPH1 Bias Register (Default Value: 0x10100010)**

Offset: 0x0244			Register Name: <b>PLL_PERIPH1_BIAS_REG</b>
Bit	R/W	Default/Hex	Description
31:29	/	/	/
28:24	R/W	0x10	PLL_VCO_BIAS. PLL VCO Bias[4:0].
23:21	/	/	/
20:16	R/W	0x10	PLL_BIAS_CUR_CTRL. PLL Bias Current Control.
15:5	/	/	/
4	R/W	0x1	PLL_BANDW_CTRL. PLL Band Width Control. 0: Narrow 1: Wide
3:2	/	/	/
1:0	R/W	0x0	PLL_DAMP_FACTOR_CTRL. PLL Damping Factor Control[1:0].



**4.3.5.59. PLL\_DE Bias Register (Default Value: 0x10100000)**

Offset: 0x0248			Register Name: <b>PLL_DE_BIAS_REG</b>
Bit	R/W	Default/Hex	Description
31:29	/	/	/
28:24	R/W	0x10	PLL_VCO_BIAS_CTRL. PLL VCO Bias Control[4:0].
23:21	/	/	/
20:16	R/W	0x10	PLL_BIAS_CTRL. PLL Bias Control[4:0].
15:3	/	/	/
2:0	R/W	0x0	PLL_DAMP_FACTOR_CTRL. PLL Damping Factor Control[2:0].

**4.3.5.60. PLL\_CPUX Tuning Register (Default Value: 0x0A101000)**

Offset: 0x0250			Register Name: <b>PLL_CPUX_TUN_REG</b>
Bit	R/W	Default/Hex	Description
31:28	/	/	/
27	R/W	0x1	PLL_BAND_WID_CTRL. PLL Band Width Control. 0: Narrow 1: Wide
26	R/W	0x0	VCO_GAIN_CTRL_EN. VCO Gain Control Enable. 0: Disable 1: Enable
25:23	R/W	0x4	VCO_GAIN_CTRL. VCO Gain Control Bits[2:0].
22:16	R/W	0x10	PLL_INIT_FREQ_CTRL. PLL Initial Frequency Control[6:0].
15	R/W	0x0	C_OD. C-Reg-Od For Verify.
14:8	R/W	0x10	C_B_IN. C-B-In[6:0] For Verify.
7	R/W	0x0	C_OD1. C-Reg-Od1 For Verify.
6:0	R	0x0	C_B_OUT. C-B-Out[6:0] For Verify.

**4.3.5.61. PLL\_DDR Tuning Register (Default Value: 0x14880000)**

Offset: 0x0260			Register Name: <b>PLL_DDR_TUN_REG</b>
Bit	R/W	Default/Hex	Description
31:29	/	/	/
28	R/W	0x1	VREG1_OUT_EN. Vreg1 Out Enable. 0: Disable 1: Enable
27	/	/	/
26:24	R/W	0x4	PLL_LTIME_CTRL. PLL Lock Time Control[2:0].
23	R/W	0x0	VCO_RST. VCO Reset In.
22:16	R/W	0x10	PLL_INIT_FREQ_CTRL. PLL Initial Frequency Control[6:0].
15	R/W	0x0	OD1. Reg-Od1 For Verify.
14:8	R/W	0x10	B_IN. B-In[6:0] For Verify.
7	R/W	0x0	OD. Reg-Od For Verify.
6:0	R	0x0	B_OUT. B-Out[6:0] For Verify.

**4.3.5.62. PLL\_CPUX Pattern Control Register (Default Value: 0x00000000)**

Offset: 0x0280			Register Name: <b>PLL_CPUX_PAT_CTRL_REG</b>
Bit	R/W	Default/Hex	Description
31	R/W	0x0	SIG_DELT_PAT_EN. Sigma-delta Pattern Enable.
30:29	R/W	0x0	SPR_FREQ_MODE. Spread Frequency Mode. 00: DC=0 01: DC=1 1X: Triangular
28:20	R/W	0x0	WAVE_STEP. Wave Step.
19	/	/	/
18:17	R/W	0x0	FREQ. Frequency. 00: 31.5KHz 01: 32KHz

			10: 32.5KHz 11: 33KHz
16:0	R/W	0x0	WAVE_BOT. Wave Bottom.

**4.3.5.63. PLL\_AUDIO Pattern Control Register(Default Value: 0x00000000)**

Offset: 0x0284			Register Name: PLL_AUDIO_PAT_CTRL_REG
Bit	R/W	Default/Hex	Description
31	R/W	0x0	SIG_DELT_PAT_EN. Sigma-delta Pattern Enable.
30:29	R/W	0x0	SPR_FREQ_MODE. Spread Frequency Mode. 00: DC=0 01: DC=1 1X: Triangular
28:20	R/W	0x0	WAVE_STEP. Wave Step.
19	/	/	/
18:17	R/W	0x0	FREQ. Frequency. 00: 31.5KHz 01: 32KHz 10: 32.5KHz 11: 33KHz
16:0	R/W	0x0	WAVE_BOT. Wave Bottom.

**4.3.5.64. PLL\_VIDEO Pattern Control Register (Default Value: 0x00000000)**

Offset: 0x0288			Register Name: PLL_VIDEO_PAT_CTRL_REG
Bit	R/W	Default/Hex	Description
31	R/W	0x0	SIG_DELT_PAT_EN. Sigma-delta Pattern Enable.
30:29	R/W	0x0	SPR_FREQ_MODE. Spread Frequency Mode. 00: DC=0 01: DC=1 1X: Triangular
28:20	R/W	0x0	WAVE_STEP. Wave Step.
19	/	/	/

18:17	R/W	0x0	FREQ. Frequency. 00: 31.5KHz 01: 32KHz 10: 32.5KHz 11: 33KHz
16:0	R/W	0x0	WAVE_BOT. Wave Bottom.

**4.3.5.65. PLL\_VE Pattern Control Register (Default Value: 0x00000000)**

Offset: 0x028C			Register Name: PLL_VE_PAT_CTRL_REG
Bit	R/W	Default/Hex	Description
31	R/W	0x0	SIG_DELT_PAT_EN. Sigma-delta Pattern Enable.
30:29	R/W	0x0	SPR_FREQ_MODE. Spread Frequency Mode. 00: DC=0 01: DC=1 1X: Triangular
28:20	R/W	0x0	WAVE_STEP. Wave Step.
19	/	/	/
18:17	R/W	0x0	FREQ. Frequency. 00: 31.5KHz 01: 32KHz 10: 32.5KHz 11: 33KHz
16:0	R/W	0x0	WAVE_BOT. Wave Bottom.

**4.3.5.66. PLL\_DDR Pattern Control Register (Default Value: 0x00000000)**

Offset: 0x0290			Register Name: PLL_DDR_PAT_CTRL_REG
Bit	R/W	Default/Hex	Description
31	R/W	0x0	SIG_DELT_PAT_EN. Sigma-delta Pattern Enable.
30:29	R/W	0x0	SPR_FREQ_MODE. Spread Frequency Mode. 00: DC=0 01: DC=1 1X: Triangular

28:20	R/W	0x0	WAVE_STEP. Wave step.
19	/	/	/
18:17	R/W	0x0	FREQ. Frequency. 00: 31.5KHz 01: 32KHz 10: 32.5KHz 11: 33KHz
16:0	R/W	0x0	WAVE_BOT. Wave Bottom.

**4.3.5.67. PLL\_GPU Pattern Control Register (Default Value: 0x00000000)**

Offset: 0x029C			Register Name: PLL_GPU_PAT_CTRL_REG
Bit	R/W	Default/Hex	Description
31	R/W	0x0	SIG_DELT_PAT_EN. Sigma-Delta Pattern Enable.
30:29	R/W	0x0	SPR_FREQ_MODE. Spread Frequency Mode. 00: DC=0 01: DC=1 1X: Triangular
28:20	R/W	0x0	WAVE_STEP. Wave Step.
19	/	/	/
18:17	R/W	0x0	FREQ. Frequency. 00: 31.5KHz 01: 32KHz 10: 32.5KHz 11: 33KHz
16:0	R/W	0x0	WAVE_BOT. Wave Bottom.

**4.3.5.68. PLL\_PERIPH1 Pattern Control Register (Default Value: 0x00000000)**

Offset: 0x02A4			Register Name: PLL_PERIPH1_PAT_CTRL_REG
Bit	R/W	Default/Hex	Description
31	R/W	0x0	SIG_DELT_PAT_EN. Sigma-Delta Pattern Enable.
30:29	R/W	0x0	SPR_FREQ_MODE.

			Spread Frequency Mode. 00: DC=0 01: DC=1 1X: Triangular
28:20	R/W	0x0	WAVE_STEP. Wave Step.
19	/	/	/
18:17	R/W	0x0	FREQ. Frequency. 00: 31.5KHz 01: 32KHz 10: 32.5KHz 11: 33KHz
16:0	R/W	0x0	WAVE_BOT. Wave Bottom.

**4.3.5.69. PLL\_DE Pattern Control Register (Default Value: 0x00000000)**

Offset: 0x02A8			Register Name: <b>PLL_DE_PAT_CTRL_REG</b>
Bit	R/W	Default/Hex	Description
31	R/W	0x0	SIG_DELT_PAT_EN. Sigma-Delta Pattern Enable.
30:29	R/W	0x0	SPR_FREQ_MODE. Spread Frequency Mode. 00: DC=0 01: DC=1 1X: Triangular
28:20	R/W	0x0	WAVE_STEP. Wave Step.
19	/	/	/
18:17	R/W	0x0	FREQ. Frequency. 00: 31.5KHz 01: 32KHz 10: 32.5KHz 11: 33KHz
16:0	R/W	0x0	WAVE_BOT. Wave Bottom.

**4.3.5.70. Bus Software Reset Register 0 (Default Value: 0x00000000)**

Offset: 0x02C0	Register Name: <b>BUS_SOFT_RST_REG0</b>
----------------	---

Bit	R/W	Default/Hex	Description
31	R/W	0x0	USBOHCI3_RST. USB OHCI3 Reset Control 0: Assert 1: De-assert
30	R/W	0x0	USBOHCI2_RST. USB OHCI2 Reset Control 0: Assert 1: De-assert
29	R/W	0x0	USBOHCI1_RST. USB OHCI1 Reset Control 0: Assert 1: De-assert
28	R/W	0x0	USB_OTG_OHCI0_RST. USB OTG_OHCI0 Reset Control 0: Assert 1: De-assert
27	R/W	0x0	USB_EHCI3_RST. USB EHCI3 Reset Control 0: Assert 1: De-assert
26	R/W	0x0	USB_EHCI2_RST. USB EHCI2 Reset Control 0: Assert 1: De-assert
25	R/W	0x0	USB_EHCI1_RST. USB EHCI1 Reset Control 0: Assert 1: De-assert.
24	R/W	0x0	USB_OTG_EHCI0_RST. USB OTG_EHCI0 Reset Control 0: Assert 1: De-assert
23	R/W	0x0	USB_OTG_Device_RST. USB OTG_Device Reset Control 0: Assert 1: De-assert
22	/	/	/
21	R/W	0x0	SPI1_RST. SPI1 Reset. 0: Assert 1: De-assert
20	R/W	0x0	SPIO_RST. SPIO Reset. 0: Assert

			1: De-assert
19	R/W	0x0	HSTMR_RST. HSTMR Reset. 0: Assert 1: De-assert
18	R/W	0x0	TS_RST. TS Reset. 0: Assert 1: De-assert
17	R/W	0x0	EMAC_RST. EMAC Reset. 0: Assert 1: De-assert
16:15	/	/	/
14	R/W	0x0	SDRAM_RST. SDRAM AHB Reset. 0: Assert 1: De-assert
13	R/W	0x0	NAND_RST. NAND Reset. 0: Assert 1: De-assert
12:11	/	/	/
10	R/W	0x0	SD2_RST. SD/MMC2 Reset. 0: Assert 1: De-assert
9	R/W	0x0	SD1_RST. SD/MMC1 Reset. 0: Assert 1: De-assert
8	R/W	0x0	SD0_RST. SD/MMC0 Reset. 0: Assert 1: De-assert
7	/	/	/
6	R/W	0x0	DMA_RST. DMA Reset. 0: Assert 1: De-assert
5	R/W	0x0	CE_RST. CE Reset. 0: Assert 1: De-assert
4:0	/	/	/



**4.3.5.71. Bus Software Reset Register 1 (Default Value: 0x00000000)**

Offset: 0x02C4			Register Name: <b>BUS_SOFT_RST_REG1</b>
Bit	R/W	Default/Hex	Description
31	R/W	0x0	DBGSYS_RST. DBGSYS Reset. 0: Assert 1: De-assert
30:23	/	/	/
22	R/W	0x0	SPINLOCK_RST. SPINLOCK Reset. 0: Assert 1: De-assert.
21	R/W	0x0	MSGBOX_RST. MSGBOX Reset. 0: Assert 1: De-assert.
20	R/W	0x0	GPU_RST. GPU Reset. 0: Assert 1: De-assert.
19:13	/	/	/
12	R/W	0x0	DE_RST. DE Reset. 0: Assert 1: De-assert.
11	R/W	0x0	HDMI1_RST. HDMI1 Reset. 0: Assert 1: De-assert.
10	R/W	0x0	HDMI0_RST. HDMI0 Reset. 0: Assert 1: De-assert.
9	R/W	0x0	TVE_RST. TVE Reset. 0: Assert 1: De-assert
8	R/W	0x0	CSI_RST. CSI Reset. 0: Assert 1: De-assert.
7:6	/	/	

5	R/W	0x0	DEINTERLACE_RST. DEINTERLACE Reset. 0: Assert 1:De-assert
4	R/W	0x0	TCON1_RST. TCON1 Reset. 0: Assert 1: De-assert.
3	R/W	0x0	TCON0_RST. TCON0 Reset. 0: Assert 1: De-assert.
2:1	/	/	/
0	R/W	0x0	VE_RST. VE Reset. 0: Assert 1: De-assert.

**4.3.5.72. Bus Software Reset Register 2 (Default Value: 0x00000000)**

Offset: 0x02C8			Register Name: <b>BUS_SOFT_RST_REG2</b>
Bit	R/W	Default/Hex	Description
31:3	/	/	/
2	R/W	0x0	EPHY_RST. EPHY Reset. 0: Assert 1: De-assert
1:0	/	/	/

**4.3.5.73. Bus Software Reset Register 3 (Default Value: 0x00000000)**

Offset: 0x02D0			Register Name: <b>BUS_SOFT_RST_REG3</b>
Bit	R/W	Default/Hex	Description
31:15	/	/	/
14	R/W	0x0	I2S/PCM 2_RST. I2S/PCM 2 Reset. 0: Assert 1: De-assert.
13	R/W	0x0	I2S/PCM 1_RST. I2S/PCM 1 Reset. 0: Assert 1: De-assert.
12	R/W	0x0	I2S/PCM 0_RST.

			I2S/PCM 0 Reset. 0: Assert 1: De-assert.
11:9	/	/	/
8	R/W	0x0	THS_RST. THS Reset. 0: Assert 1: De-assert
7:2	/	/	/
1	R/W	0x0	OWA_RST. OWA Reset. 0: Assert 1: De-assert
0	R/W	0x0	AC_RST. AC Reset. 0: Assert 1: De-assert

**4.3.5.74. Bus Software Reset Register 4 (Default Value: 0x00000000)**

Offset: 0x02D8			Register Name: <b>BUS_SOFT_RST_REG4</b>
Bit	R/W	Default/Hex	Description
31:21	/	/	/
20	R/W	0x0	SCR_RST. SCR Reset. 0: Assert 1: De-assert
19	R/W	0x0	UART3_RST. UART3 Reset. 0: Assert 1: De-assert.
18	R/W	0x0	UART2_RST. UART2 Reset. 0: Assert 1: De-assert.
17	R/W	0x0	UART1_RST. UART1 Reset. 0: Assert 1: De-assert.
16	R/W	0x0	UART0_RST. UART0 Reset. 0: Assert 1: De-assert.
15:3	/	/	/

2	R/W	0x0	TWI2_RST. TWI2 Reset. 0: Assert 1: De-assert.
1	R/W	0x0	TWI1_RST. TWI1 Reset. 0: Assert 1: De-assert.
0	R/W	0x0	TWI0_RST. TWI0 Reset. 0: Assert 1: De-assert.

#### 4.3.5.75. CCU Security Switch Register (Default Value: 0x00000000)

Offset: 0x02F0			Register Name: <b>CCU_SEC_SWITCH_REG</b>
Bit	R/W	Default/Hex	Description
31:3	/	/	/
2	R/W	0x0	MBUS_SEC MBUS clock register security 0:Secure 1:Non-secure Including MBUS Reset Register and MBUS Clock Register
1	R/W	0x0	BUS_SEC Bus relevant registers' security 0:Secure 1:Non-secure Including AXI/AHB/APB relevant registers,such as CPUX/AXI Configuration Register,AHB1/APB1 Configuration Register,APB2 Configuration Register, AHB2 Configuration Register.
0	R/W	0x0	PLL_SEC PLL relevant registers' security. 0:Secure 1:Non-secure Including PLL_CPUX Control Register,PLL_AUDIO Control Register,PLL_VIDEO Control Register,PLL_VE Control Register,PLL_DDR Control Register,PLL_PEPH0 Control Register,PLL_GPU Control Register,PLL_PERIPH1 Control Register,PLL_DE Control Register and offset from 0x200 to 0x2A8 relevant registers.

#### 4.3.5.76. PS Control Register (Default Value: 0x00000000)

Offset: 0x0300	Register Name: <b>PS_CTRL_REG</b>
----------------	-----------------------------------

Bit	R/W	Default/Hex	Description
31:8	/	/	/
7	R/W	0x0	DET_FIN. Detect Finish. 0: Unfinished 1: Finished Set 1 to this bit will clear it.
6	R/W	0x0	DLY_SEL. Delay Select 0: 1 Cycle 1: 2 Cycles
5:4	R/W	0x0	OSC_SEL OSC Select. 00: IDLE 01: SVT 10: LVT 11: ULVT
3:1	R/W	0x0	TIME_DET. Time detect. 000: 0.5/4 us 001: 0.5/2 us 002: 0.5/1 us 003: 0.5*2us ..... 111:0.5*2^5us
0	R/W	0x0	MOD_EN. Module enable. 0: Disable 1: Enable

**4.3.5.77. PS Counter Register (Default Value: 0x00000000)**

Offset: 0x0304			Register Name: PS_CNT_REG
Bit	R/W	Default/Hex	Description
31:16	/	/	/
15:0	R/W	0x0	PS_CNT. PS Counter.

### 4.3.6. Programming Guidelines

#### 4.3.6.1. PLL

- 1) In practical application, other PLLs doesn't support dynamic frequency scaling except for PLL\_CPUX;
- 2) After the PLL\_DDR frequency changes, the 20-bit of PLL\_DDR Control Register should be written 1 to make it valid;

#### 4.3.6.2. BUS

- 1) When setting the BUS clock , you should set the division factor first, and after the division factor becomes valid, switch the clock source. The clock source will be switched after at least three clock cycles;
- 2) The BUS clock should not be dynamically changed in most applications.

#### 4.3.6.3. Clock Switch

Make sure that the clock source output is valid before the clock source switch, and then set a proper divide ratio; after the division factor becomes valid, switch the clock source.

#### 4.3.6.4. Gating and reset

Make sure that the reset signal has been released before the release of module clock gating;

## 4.4. CPU Configuration

### 4.4.1. Overview

CPUCFG module is used to configure related CPU parameters.

It features:

- Software Reset Control for every CPU
- CPU Configuration for every CPU
- One 64-bit common counter

### 4.4.2. Register List

Module Name	Base Address
CPUCFG	0x01F01C00

Register Name	Offset	Description
CPUS_RST_CTRL_REG	0x0000	CPUS reset control register
CPU0_RST_CTRL	0x0040	CPU0 reset control
CPU0_CTRL_REG	0x0044	CPU0 control register
CPU0_STATUS_REG	0x0048	CPU0 status register
CPU1_RST_CTRL	0x0080	CPU1 reset control
CPU1_CTRL_REG	0x0084	CPU1 control register
CPU1_STATUS_REG	0x0088	CPU1 status register
CPU2_RST_CTRL	0x00C0	CPU2 reset control
CPU2_CTRL_REG	0x00C4	CPU2 control register
CPU2_STATUS_REG	0x00C8	CPU2 status register
CPU3_RST_CTRL	0x0100	CPU3 reset control
CPU3_CTRL_REG	0x0104	CPU3 control register
CPU3_STATUS_REG	0x0108	CPU3 status register
CPU_SYS_RST_REG	0x0140	CPU System Reset Register
CPU_CLK_GATING_REG	0x0144	CPU clock gating Register
GENER_CTRL_REG	0x0184	General Control Register
SUP_STAN_FLAG_REG	0x01A0	Super Standby Flag Register
CNT64_CTRL_REG	0x0280	64-bit Counter Control Register
CNT64_LOW_REG	0x0284	64-bit Counter Low Register
CNT64_HIGH_REG	0x0288	64-bit Counter High Register

### 4.4.3. Register Description

#### 4.4.3.1. CPUS Reset Control Register(Default Value: 0x00000000)

Offset: 0x00			Register Name: <b>CPUS_RST_CTRL_REG</b>
Bit	R/W	Default/Hex	Description
31:1	/	/	/
0	R/W	0x0	CPUS_RESET. CPUS Reset Assert. 0: assert 1: de-assert.

#### 4.4.3.2. CPU0 Reset Control Register(Default Value: 0x00000000)

Offset: 0x40			Register Name: <b>CPU0_RST_CTRL_REG</b>
Bit	R/W	Default/Hex	Description
31:2	/	/	/
1	R/W	0x1	CPU0_CORE_REST. These are the primary reset signals which initialize the processor logic in the processor power domains, not including the debug, breakpoint and watchpoint logic. 0: assert 1: de-assert.
0	R/W	0x1	CPU0_RESET. CPU0 Power-on Reset Assert. These power-on reset signals initialize all the processor logic, including CPU Debug, and breakpoint and watch point logic in the processor power domains. They do not reset debug logic in the debug power domain. 0: assert 1: de-assert.

#### 4.4.3.3. CPU0 Control Register(Default Value: 0x00000000)

Offset: 0x44			Register Name: <b>CPU0_CTRL_REG</b>
Bit	R/W	Default/Hex	Description
31:1	/	/	/
0	R/W	0x0	CPU0_CP15_WRITE_DISABLE. Disable write access to certain CP15 registers. 0: enable 1: disable



**4.4.3.4. CPU0 Status Register (Default Value: 0x00000000)**

Offset: 0x48			Register Name: CPU0_STATUS_REG
Bit	R/W	Default/Hex	Description
31:3	/	/	/
2	R	0x0	STANDBYWFI. Indicates if the processor is in WFI standby mode: 0: Processor not in WFI standby mode. 1: Processor in WFI standby mode
1	R	0x0	STANDBYWFE. Indicates if the processor is in the WFE standby mode: 0: Processor not in WFE standby mode 1: Processor in WFE standby mode
0	R	0x0	SMP_AMP 0: AMP mode 1: SMP mode

**4.4.3.5. CPU1 Reset Register(Default Value: 0x00000001)**

Offset: 0x80			Register Name: CPU1_RST_CTRL_REG
Bit	R/W	Default/Hex	Description
31:2	/	/	/
1	R/W	0x0	CPU1_CORE_REST. These are the primary reset signals which initialize the processor logic in the processor power domains, not including the debug, breakpoint and watchpoint logic. 0: assert 1: de-assert.
0	R/W	0x1	CPU1_RESET. CPU1 Power-on Reset Assert. These power-on reset signals initialize all the processor logic, including CPU Debug, and breakpoint and watch point logic in the processor power domains. They do not reset debug logic in the debug power domain. 0: assert 1: de-assert.

**4.4.3.6. CPU1 Control Register(Default Value: 0x00000000)**

Offset: 0x84			Register Name: CPU1_CTRL_REG
Bit	R/W	Default/Hex	Description
31:1	/	/	/
0	R/W	0x0	CPU1_CP15_WRITE_DISABLE.

			Disable write access to certain CP15 registers. 0: enable 1: disable
--	--	--	--

**4.4.3.7. CPU1 Status Register(Default Value: 0x00000000)**

Offset: 0x88			Register Name: <b>CPU1_STATUS_REG</b>
Bit	R/W	Default/Hex	Description
31:3	/	/	/.
2	R	0x0	STANDBYWFI. Indicates if the processor is in WFI standby mode: 0: Processor not in WFI standby mode. 1: Processor in WFI standby mode
1	R	0x0	STANDBYWFE. Indicates if the processor is in the WFE standby mode: 0: Processor not in WFE standby mode 1: Processor in WFE standby mode
0	R	0x0	SMP_AMP 0: AMP mode 1: SMP mode

**4.4.3.8. CPU2 Reset Control Register(Default Value: 0x00000001)**

Offset: 0xC0			Register Name: <b>CPU2_RST_CTRL_REG</b>
Bit	R/W	Default/Hex	Description
31:2	/	/	/.
1	R/W	0x0	CPU2_CORE_REST. These are the primary reset signals which initialize the processor logic in the processor power domains, not including the debug, breakpoint and watch point logic. 0: assert 1: de-assert.
0	R/W	0x1	CPU2_RESET. CPU2 Reset Assert. These power-on reset signals initialize all the processor logic, including CPU Debug, and breakpoint and watch point logic in the processor power domains. They do not reset debug logic in the debug power domain. 0: assert 1: de-assert.

**4.4.3.9. CPU2 Control Register(Default Value: 0x00000000)**

Offset: 0xC4			Register Name: CPU2_CTRL_REG
Bit	R/W	Default/Hex	Description
31:1	/	/	/
0	R/W	0x0	CPU2_CP15_WRITE_DISABLE. Disable write access to certain CP15 registers. 0: enable 1: disable

**4.4.3.10. CPU2 Status Register(Default Value: 0x00000000)**

Offset: 0xC8			Register Name: CPU2_STATUS_REG
Bit	R/W	Default/Hex	Description
31:3	/	/	/.
2	R	0x0	STANDBYWFI. Indicates if the processor is in WFI standby mode: 0: Processor not in WFI standby mode. 1: Processor in WFI standby mode
1	R	0x0	STANDBYWFE. Indicates if the processor is in the WFE standby mode: 0: Processor not in WFE standby mode 1: Processor in WFE standby mode
0	R	0x0	SMP_AMP 0: AMP mode 1: SMP mode

**4.4.3.11. CPU3 Reset Control Register(Default Value: 0x00000001)**

Offset: 0x100			Register Name: CPU3_RST_CTRL_REG
Bit	R/W	Default/Hex	Description
31:2	/	/	/.
1	R/W	0x0	CPU3_CORE_REST. These are the primary reset signals which initialize the processor logic in the processor power domains, not including the debug, breakpoint and watch point logic. 0: assert 1: de-assert.
0	R/W	0x1	CPU3_RESET. CPU3 Reset Assert. These power-on reset signals initialize all the processor logic, including CPU Debug, and breakpoint and watch point logic in the processor power

			domains. They do not reset debug logic in the debug power domain. 0: assert 1: de-assert.
--	--	--	---

**4.4.3.12. CPU3 Control Register(Default Value: 0x00000000)**

Offset: 0x104			Register Name: <b>CPU3_CTRL_REG</b>
Bit	R/W	Default/Hex	Description
31:1	/	/	/
0	R/W	0x0	CPU3_CP15_WRITE_DISABLE. Disable write access to certain CP15 registers. 0: enable 1: disable

**4.4.3.13. CPU3 Status Register(Default Value: 0x00000000)**

Offset: 0x108			Register Name: <b>CPU3_STATUS_REG</b>
Bit	R/W	Default/Hex	Description
31:3	/	/	/.
2	R	0x0	STANDBYWFI. Indicates if the processor is in WFI standby mode: 0: Processor not in WFI standby mode. 1: Processor in WFI standby mode
1	R	0x0	STANDBYWFE. Indicates if the processor is in the WFE standby mode: 0: Processor not in WFE standby mode 1: Processor in WFE standby mode
0	R	0x0	SMP_AMP 0: AMP mode 1: SMP mode

**4.4.3.14. CPU System Reset Control Register(Default Value: 0x00000001)**

Offset: 0x140			Register Name: <b>CPU_SYS_RST_REG</b>
Bit	R/W	Default/Hex	Description
31:1	/	/	/
0	R/W	0x1	CPU System Reset Control. 0: assert 1: de-assert.

**4.4.3.15. CPU Clock Gating Register(Default Value: 0x0000010F)**

Offset: 0x144			Register Name: CPU_CLK_GATING_REG
Bit	R/W	Default/Hex	Description
31:9	/	/	/
8	R/W	0x1	L2_CLK_GATING L2 Clock gating 0: clock off 1: clock on
7:4	/	/	/
3:0	R/W	0xF	CPU_CLK_GATING CPU0/1/2/3 Clock gating 0: clock off 1: clock on

**4.4.3.16. General Control Register(Default Value: 0x00000020)**

Offset: 0x184			Register Name: GENER_CTRL_REG
Bit	R/W	Default/Hex	Description
31:9	/	/	/.
8	R/W	0x0	CFGSDISABLE. Disables write access to some secure GIC registers.
7	/	/	/
6	R/W	0x0	ACINACTM. Snoop interface is inactive and no longer accepting requests.
5	R/W	0x1	L2_RST. L2 Reset.(SCU global reset) 0: Apply reset to shared L2 memory system controller. 1: Do not apply reset to shared L2 memory system controller.
4	R/W	0x0	L2_RST_DISABLE. Disable automatic L2 cache invalidate at reset: 0: L2 cache is reset by hardware. 1: L2 cache is not reset by hardware.
3:0	R/W	0x0	L1_RST_DISABLE. L1 Reset Disable[3:0]. 0: L1 cache is reset by hardware. 1: L1 cache is not reset by hardware.

**4.4.3.17. Super Standby Flag Register(Default Value: 0x00000000)**

Offset: 0x1A0			Register Name: SUP_STAN_FLAG_REG
Bit	R/W	Default/Hex	Description

31:16	R/W	0x0	SUP_STANDBY_FLAG. Key Field. Any value can be written and read back in the key field, but if the values are not appropriate, the lower 16 bits will not change in this register. Only follow the appropriate process, the super standby flag can be written in the lower 16 bits. Refer to Description and Diagram.
15:0	R/W	0x0	SUP_STANBY_FLAG_DATA. Refer to Description and Diagram

**Note:** When system is turned on, the value in the Super Standby Flag Register low 16 bits should be 0x0. If software programmer wants to write correct super standby flag ID in low 16 bits, the high 16 bits should be written 0x16AA at first. Then, software programmer must write 0xAA16XXXX in the Super Standby Flag Register, the 'XXXX' means the correct super standby flag ID. Referring to the Diagram section (Diagram 1.1) in detail.

**4.4.3.18. 64-bit Counter Control Register(Default Value: 0x00000000)**

Offset: 0x280			Register Name: <b>CNT64_CTRL_REG</b>
Bit	R/W	Default/Hex	Description
31:3	/	/	/.
2	R/W	0x0	CNT64_CLK_SRC_SEL. 64-bit Counter Clock Source Select. 0: OSC24M 1: /
1	R/W	0x0	CNT64_RL_EN. 64-bit Counter Read Latch Enable. 0: no effect, 1: to latch the 64-bit Counter to the Low/Hi registers and it will change to zero after the registers are latched.
0	R/W	0x0	CNT64_CLR_EN. 64-bit Counter Clear Enable. 0: no effect, 1: to clear the 64-bit Counter Low/Hi registers and it will change to zero after the registers are cleared. Note: It is not recommended to clear this counter arbitrarily.

**Note:** This 64-bit counter will start to count as soon as the System Power On finished.

**4.4.3.19. 64-bit Counter Low Register(Default Value: 0x00000000)**

Offset: 0x284			Register Name: <b>CNT64_LOW_REG</b>
Bit	R/W	Default/Hex	Description
31:0	R/W	0x0	CNT64_LO. 64-bit Counter [31:0].

**4.4.3.20. 64-bit Counter High Register(Default Value: 0x00000000)**

Offset: 0x288			Register Name: <b>CNT64_High_REG</b>
Bit	R/W	Default/Hex	Description
31:0	R/W	0x0	CNT64_LO. 64-bit Counter [63:32].

Confidential

## 4.5. System Control

### 4.5.1. Overview

Area	Size(Bytes)
A1	64K
A2	32K
CPUX I-Cache	32K (X=0,1,2,3)
CPUX D-Cache	32K (X=0,1,2,3)
CPU L2 Cache	512K
Total	864K

### 4.5.2. System Control Register List

Module Name	Base Address
System Control	0x01C00000

Register Name	Offset	Description
VER_REG	0x24	Version Register
EMAC_EPHY_CLK_REG	0x30	EMAC-EPHY Clock Register

### 4.5.3. System Control Register Description

#### 4.5.3.1. Version Register

Offset:0x24			Register Name: <b>VER_REG</b>
Bit	R/W	Default/Hex	Description
31:9	/	/	/
8	R	x	UBOOT_SEL_PAD_STA. U_boot Select Pin Status. 0: U_Boot; 1: Normal Boot.
7:0	R	0x0	VER_BITS. This read-only bit field always reads back the mask revision level of the chip.



**4.5.3.2. EMAC Clock Register (Default Value: 0x00058000)**

Offset:0x30			Register Name: <b>EMAC_CLK_REG</b>
Bit	R/W	Default/Hex	Description
31:28	R/W	0x0	BPS_EFFUSE
27	R/W	0x0	XMII_SEL 0: Internal SMI and MII 1: External SMI and MII
26:25	R/W	0x0	EPHY_MODE Operation Mode Selection 00 : Normal Mode 01 : Sim Mode 10 : AFE Test Mode 11 : /
24:20	R/W	0x0	PHY_ADDR PHY Address
19	R/W	0x0	BIST_CLK_EN 0 : BIST clk disable 1 : BIST clk enable
18	R/W	0x1	CLK_SEL 0 : 25MHz 1 : 24MHz
17	R/W	0x0	LED_POL 0 : High active 1 : Low active
16	R/W	0x1	SHUTDOWN 0 : Power up 1 : Shutdown
15	R/W	0x1	PHY_SELECT. 0 : External PHY 1 : Internal PHY
14	/	/	/
13	R/W	0x0	RMII_EN 0 : Disable RMII Module 1 : Enable RMII Module When this bit assert, MII or RGMII interface is disabled( This means bit13 is prior to bit2)
12:10	R/W	0x0	ETXDC. Configure EMAC Transmit Clock Delay Chain.
9:5	R/W	0x0	ERXDC. Configure EMAC Receive Clock Delay Chain.
4	R/W	0x0	ERXIE Enable EMAC Receive Clock Invertor. 0: Disable

			1: Enable
3	R/W	0x0	ETXIE Enable EMAC Transmit Clock Invertor. 0: Disable 1: Enable
2	R/W	0x0	EPIT EMAC PHY Interface Type 0: MII 1: RGMII
1:0	R/W	0x0	ETCS. EMAC Transmit Clock Source 00: Transmit clock source for MII 01: External transmit clock source for GMII and RGMII 10: Internal transmit clock source for GMII and RGMII 11: Reserved

Confidential

## 4.6. Timer

### 4.6.1. Overview

Timer 0/1 can take their inputs from Internal OSC or OSC24M. They provide the operating system's scheduler interrupt. It is designed to offer maximum accuracy and efficient management, even for systems with long or short response time. They provide 24-bit programmable overflow counter and work in auto-reload mode or no-reload mode. When the current value in *Current Value Register* is counting down to zero, the timer will generate interrupt if set interrupt enable bit.

The watchdog is used to resume the controller operation when it had been disturbed by malfunctions such as noise and system errors. It features a down counter that allows a watchdog period of up to 16 seconds (512000 cycles). It can generate a general reset or interrupt request.

### 4.6.2. Block Diagram

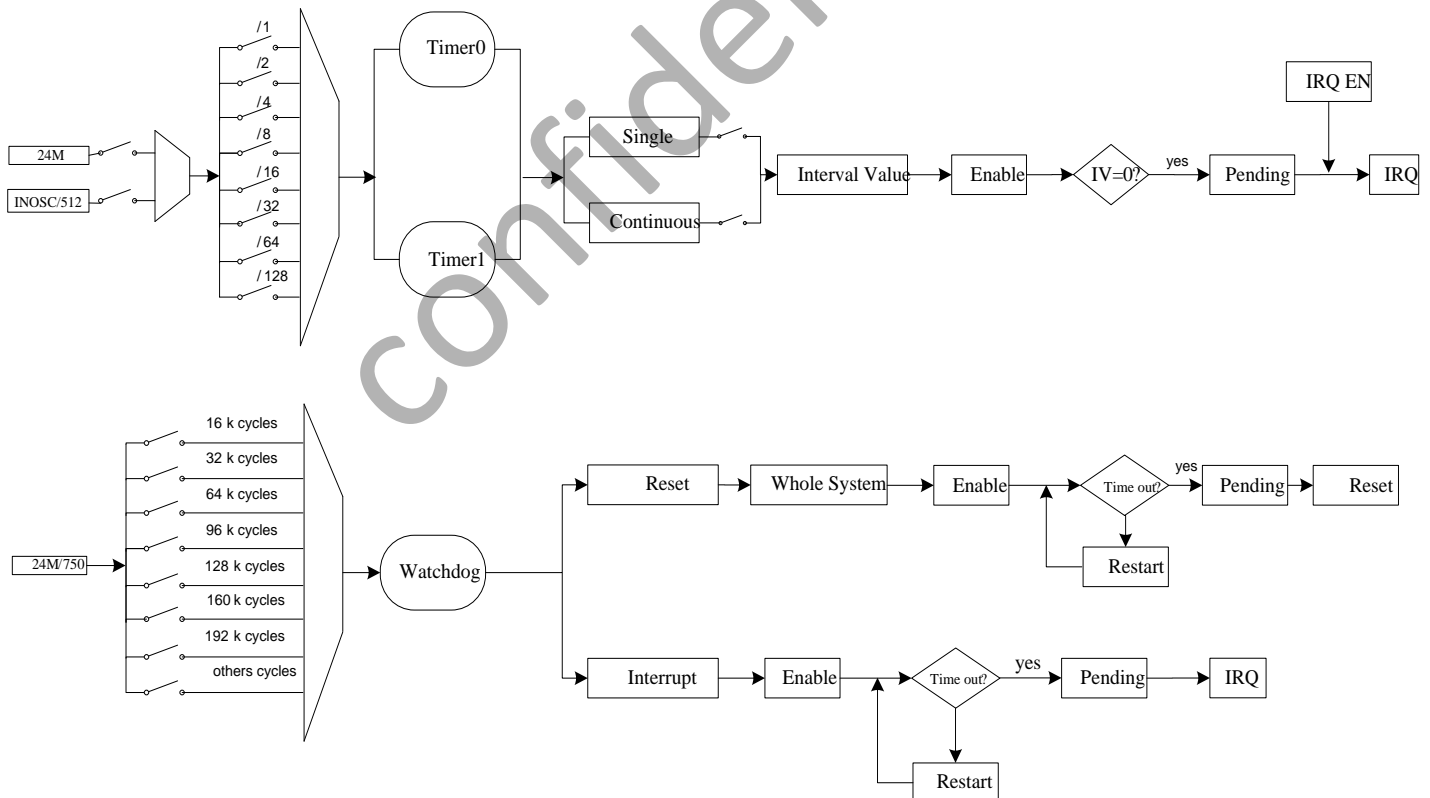

Figure 4-3. Timer Block Diagram

### 4.6.3. Timer Register List

Module Name	Base Address
TIMER	0x01C20C00

Register Name	Offset	Description
TMR_IRQ_EN_REG	0x0	Timer IRQ Enable Register
TMR_IRQ_STA_REG	0x4	Timer Status Register
TMRO_CTRL_REG	0x10	Timer 0 Control Register
TMRO_INTV_VALUE_REG	0x14	Timer 0 Interval Value Register
TMRO_CUR_VALUE_REG	0x18	Timer 0 Current Value Register
TMR1_CTRL_REG	0x20	Timer 1 Control Register
TMR1_INTV_VALUE_REG	0x24	Timer 1 Interval Value Register
TMR1_CUR_VALUE_REG	0x28	Timer 1 Current Value Register
AVS_CNT_CTL_REG	0x80	AVS Control Register
AVS_CNT0_REG	0x84	AVS Counter 0 Register
AVS_CNT1_REG	0x88	AVS Counter 1 Register
AVS_CNT_DIV_REG	0x8C	AVS Divisor Register
WDOG0_IRQ_EN_REG	0xA0	Watchdog 0 IRQ Enable Register
WDOG0_IRQ_STA_REG	0xA4	Watchdog 0 Status Register
WDOG0_CTRL_REG	0xB0	Watchdog 0 Control Register
WDOG0_CFG_REG	0xB4	Watchdog 0 Configuration Register
WDOG0_MODE_REG	0xB8	Watchdog 0 Mode Register

### 4.6.4. Timer Register Description

#### 4.6.4.1. Timer IRQ Enable Register (Default Value: 0x00000000)

Offset:0x0			Register Name: TMR_IRQ_EN_REG
Bit	R/W	Default/Hex	Description
31:2	/	/	/
1	R/W	0x0	TMR1_IRQ_EN. Timer 1 Interrupt Enable. 0: No effect; 1: Timer 1 Interval Value reached interrupt enable.
0	R/W	0x0	TMRO_IRQ_EN. Timer 0 Interrupt Enable. 0: No effect; 1: Timer 0 Interval Value reached interrupt enable.

**4.6.4.2. Timer IRQ Status Register (Default Value: 0x00000000)**

Offset:0x04			Register Name: TMR_IRQ_STA_REG
Bit	R/W	Default/Hex	Description
31:2	/	/	/
1	R/W	0x0	TMR1_IRQ_PEND. Timer 1 IRQ Pending. Set 1 to the bit will clear it. 0: No effect; 1: Pending, timer 1 interval value is reached.
0	R/W	0x0	TMRO_IRQ_PEND. Timer 0 IRQ Pending. Set 1 to the bit will clear it. 0: No effect; 1: Pending, timer 0 interval value is reached.

**4.6.4.3. Timer 0 Control Register (Default Value: 0x00000004)**

Offset:0x10			Register Name: TMRO_CTRL_REG
Bit	R/W	Default/Hex	Description
31:8	/	/	/
7	R/W	0x0	TMRO_MODE. Timer 0 mode. 0: Continuous mode. When interval value reached, the timer will not disable automatically. 1: Single mode. When interval value reached, the timer will disable automatically.
6:4	R/W	0x0	TMRO_CLK_PRE. Select the pre-scale of timer 0 clock source. 000: /1 001: /2 010: /4 011: /8 100: /16 101: /32 110: /64 111: /128
3:2	R/W	0x1	TMRO_CLK_SRC. Timer 0 Clock Source. 00: Internal OSC / N 01: OSC24M. 10: / 11: / Internal OSC / N is about 32KHz.
1	R/W	0x0	TMRO_RELOAD.

			<p>Timer 0 Reload.</p> <p>0: No effect</p> <p>1: Reload timer 0 Interval value.</p> <p>After the bit is set, it can not be written again before it's cleared automatically.</p>
0	R/W	0x0	<p>TMRO_EN.</p> <p>Timer 0 Enable.</p> <p>0: Stop/Pause</p> <p>1: Start.</p> <p>When the timer is started, it will reload the interval value to internal register, and the current counter will count from interval value to 0. If the current counter does not reach the zero, the timer enable bit is set to "0", the current value counter will pause. At least wait for 2 cycles, the start bit can be set to 1. In timer pause state; the interval value register can be modified. If the timer is started again, and the Software hope the current value register to down-count from the new interval value, the reload bit and the enable bit should be set to 1 at the same time.</p>

**4.6.4.4. Timer 0 Interval Value Register**

Offset:0x14			Register Name: <b>TMRO_INTV_VALUE_REG</b>
Bit	R/W	Default/Hex	Description
31:0	R/W	0x0	<p>TMRO_INTV_VALUE.</p> <p>Timer 0 Interval Value.</p>

**Note:**The value setting should consider the system clock and the timer clock source.

**4.6.4.5. Timer 0 Current Value Register**

Offset:0x18			Register Name: <b>TMRO_CUR_VALUE_REG</b>
Bit	R/W	Default/Hex	Description
31:0	R/W	0x0	<p>TMRO_CUR_VALUE.</p> <p>Timer 0 Current Value.</p>

**Note:** Timer0 current value is a 32-bit down-counter (from interval value to 0).

**4.6.4.6. Timer 1 Control Register (Default Value: 0x00000004)**

Offset:0x20			Register Name: <b>TMR1_CTRL_REG</b>
Bit	R/W	Default/Hex	Description
31:8	/	/	/
7	R/W	0x0	<p>TMR1_MODE.</p> <p>Timer 1 mode.</p> <p>0: Continuous mode. When interval value reached, the timer will not disable</p>

			<p>automatically.</p> <p>1: Single mode. When interval value reached, the timer will disable automatically.</p>
6:4	R/W	0x0	<p>TMR1_CLK_PRES.</p> <p>Select the pre-scale of timer 1 clock source.</p> <p>000: /1 001: /2 010: /4 011: /8 100: /16 101: /32 110: /64 111: /128</p>
3:2	R/W	0x1	<p>TMR1_CLK_SRC.</p> <p>00: Internal OSC / N 01: OSC24M. 10: / 11: /.</p> <p>Internal OSC / N is about 32KHz.</p>
1	R/W	0x0	<p>TMR1_RELOAD.</p> <p>Timer 1 Reload.</p> <p>0: No effect 1: Reload timer 1 Interval value.</p> <p>After the bit is set, it can not be written again before it's cleared automatically.</p>
0	R/W	0x0	<p>TMR1_EN.</p> <p>Timer 1 Enable.</p> <p>0: Stop/Pause 1: Start.</p> <p>If the timer is started, it will reload the interval value to internal register, and the current counter will count from interval value to 0.</p> <p>If the current counter does not reach the zero, the timer enable bit is set to "0", the current value counter will pause. At least wait for 2 cycles, the start bit can be set to 1.</p> <p>In timer pause state, the interval value register can be modified. If the timer is started again, and the Software hope the current value register to down-count from the new interval value, the reload bit and the enable bit should be set to 1 at the same time.</p>

#### 4.6.4.7. Timer 1 Interval Value Register

Offset:0x24			Register Name: <b>TMR1_INTV_VALUE_REG</b>
Bit	R/W	Default/Hex	Description
31:0	R/W	0x0	TMR1_INTV_VALUE.

			Timer 1 Interval Value.
--	--	--	-------------------------

**Note:** The value setting should consider the system clock and the timer clock source.

**4.6.4.8. Timer 1 Current Value Register**

Offset:0x28			Register Name: <b>TMR1_CUR_VALUE_REG</b>
Bit	R/W	Default/Hex	Description
31:0	R/W	0x0	TMR1_CUR_VALUE. Timer 1 Current Value.

**Note:** Timer1 current value is a 32-bit down-counter (from interval value to 0).

**4.6.4.9. AVS Counter Control Register (Default Value: 0x00000000)**

Offset:0x80			Register Name: <b>AVS_CNT_CTL_REG</b>
Bit	R/W	Default/Hex	Description
31:10	/	/	/
9	R/W	0x0	AVS_CNT1_PS. Audio/Video Sync Counter 1 Pause Control 0: Not pause 1: Pause Counter 1.
8	R/W	0x0	AVS_CNT0_PS. Audio/Video Sync Counter 0 Pause Control 0: Not pause 1: Pause Counter 0.
7:2	/	/	/
1	R/W	0x0	AVS_CNT1_EN. Audio/Video Sync Counter 1 Enable/ Disable. The counter source is OSC24M. 0: Disable 1: Enable.
0	R/W	0x0	AVS_CNT0_EN. Audio/Video Sync Counter 1 Enable/ Disable. The counter source is OSC24M. 0: Disable 1: Enable.

**4.6.4.10. AVS Counter 0 Register (Default Value: 0x00000000)**

Offset:0x84			Register Name: <b>AVS_CNT0_REG</b>
Bit	R/W	Default/Hex	Description
31:0	R/W	0x0	AVS_CNT0. Counter 0 for Audio/ Video Sync Application The high 32 bits of the internal 33-bits counter register. The initial value of



			the internal 33-bits counter register can be set by software. The LSB bit of the 33-bits counter register should be zero when the initial value is updated. It will count from the initial value. The initial value can be updated at any time. It can also be paused by setting AVS_CNT0_PS to '1'. When it is paused, the counter won't increase.
--	--	--	---

#### 4.6.4.11. AVS Counter 1 Register (Default Value: 0x00000000)

Offset:0x88			Register Name: <b>AVS_CNT1_REG</b>
Bit	R/W	Default/Hex	Description
31:0	R/W	0x0	AVS_CNT1. Counter 1 for Audio/ Video Sync Application The high 32 bits of the internal 33-bits counter register. The initial value of the internal 33-bits counter register can be set by software. The LSB bit of the 33-bits counter register should be zero when the initial value is updated. It will count from the initial value. The initial value can be updated at any time. It can also be paused by setting AVS_CNT1_PS to '1'. When it is paused, the counter won't increase.

#### 4.6.4.12. AVS Counter Divisor Register (Default Value: 0x05DB05DB)

Offset:0x8C			Register Name: <b>AVS_CNT_DIV_REG</b>
Bit	R/W	Default/Hex	Description
31:28	/	/	/
27:16	R/W	0x5DB	AVS_CNT1_D. Divisor N for AVS Counter 1 AVS CN1 CLK=24MHz/Divisor_N1. Divisor N1 = Bit [27:16] + 1. The number N is from 1 to 0x7ff. The zero value is reserved. The internal 33-bits counter engine will maintain another 12-bits counter. The 12-bits counter is used for counting the cycle number of one 24Mhz clock. When the 12-bits counter reaches ( $\geq N$ ) the divisor value, the internal 33-bits counter register will increase 1 and the 12-bits counter will reset to zero and restart again. <b>Note:</b> It can be configured by software at any time.
15:12	/	/	/
11:0	R/W	0x5DB	AVS_CNT0_D. Divisor N for AVS Counter 0 AVS CN0 CLK=24MHz/Divisor_NO. Divisor N0 = Bit [11:0] + 1 The number N is from 1 to 0x7ff. The zero value is reserved. The internal 33-bits counter engine will maintain another 12-bits counter.

			<p>The 12-bits counter is used for counting the cycle number of one 24Mhz clock. When the 12-bits counter reaches (<math>\geq N</math>) the divisor value, the internal 33-bits counter register will increase 1 and the 12-bits counter will reset to zero and restart again.</p> <p><b>Note:</b> It can be configured by software at any time.</p>
--	--	--	--

**4.6.4.13. Watchdog0 IRQ Enable Register (Default Value: 0x00000000)**

Offset:0xA0			Register Name: <b>WDOG0_IRQ_EN_REG</b>
Bit	R/W	Default/Hex	Description
31:1	/	/	/
0	R/W	0x0	<p>WDOG0_IRQ_EN.            Watchdog0 Interrupt Enable.            0: No effect            1: Watchdog0 interrupt enable.</p>

**4.6.4.14. Watchdog0 Status Register (Default Value: 0x00000000)**

Offset:0xA4			Register Name: <b>WDOG0_IRQ_STA_REG</b>
Bit	R/W	Default/Hex	Description
31:1	/	/	/
0	R/W	0x0	<p>WDOG0_IRQ_PEND.            Watchdog0 n IRQ Pending. Set 1 to the bit will clear it.            0: No effect,            1: Pending, watchdog0 interval value is reached.</p>

**4.6.4.15. Watchdog0 Control Register (Default Value: 0x00000000)**

Offset:0xB0			Register Name: <b>WDOG0_CTRL_REG</b>
Bit	R/W	Default/Hex	Description
31:13	/	/	/
12:1	R/W	0x0	<p>WDOG0_KEY_FIELD.            Watchdog0 Key Field.            Should be written at value 0xA57. Writing any other value in this field aborts the write operation.</p>
0	R/W	0x0	<p>WDOG0_RSTART.            Watchdog0 Restart.            0: No effect,            1: Restart watchdog0.</p>

**4.6.4.16. Watchdog0 Configuration Register (Default Value: 0x00000001)**

Offset:0xB4			Register Name: <b>WDOG0_CFG_REG</b>
Bit	R/W	Default/Hex	Description
31:2	/	/	/
1:0	R/W	0x1	WDOG0_CONFIG. Watchdog0 generates a reset signal 00: / 01: To whole system 10: Only interrupt 11: /

**4.6.4.17. Watchdog0 Mode Register (Default Value: 0x00000000)**

Offset:0xB8			Register Name: <b>WDOG0_MODE_REG</b>
Bit	R/W	Default/Hex	Description
31:8	/	/	/
7:4	R/W	0x0	WDOG0_INTV_VALUE. Watchdog0 Interval Value Watchdog0 clock source is <i>OSC24M / 750</i> . If the clock source is turned off, Watchdog 0 will not work. 0000: 16000 cycles (0.5s) 0001: 32000 cycles (1s) 0010: 64000 cycles (2s) 0011: 96000 cycles (3s) 0100: 128000 cycles (4s) 0101: 160000 cycles (5s) 0110: 192000 cycles (6s) 0111: 256000 cycles (8s) 1000: 320000 cycles (10s) 1001: 384000 cycles (12s) 1010: 448000 cycles (14s) 1011: 512000 cycles (16s) others: /
3:1	/	/	/
0	R/W	0x0	WDOG0_EN. Watchdog0 Enable. 0: No effect; 1: Enable watchdog0.

## 4.6.5. Programming Guidelines

### 4.6.5.1. Timer

Take making a Timer0 1ms delay for an example, 24M clock source, single mode and 2 pre-scale will be selected in the instance.

```
writel(0x2EE0,TMR_0_INTV);           //Set interval value
writel(0x94, TMR_0_CTRL);           //Select Single mode,24MHz clock source,2 pre-scale
writel(readl(TMR_0_CTRL)|(1<<1), TMR_0_CTRL); //Set Reload bit
while((readl(TMR_0_CTRL)>>1)&1);     //Waiting Reload bit turns to 0
writel(readl(TMR_0_CTRL)|(1<<0), TMR_0_CTRL); //Enable Timer0
```

### 4.6.5.2. Watchdog Reset

In the following instance making configurations for Watchdog: configurate clock source as 24M/750, configurate Interval Value as 1s and configurate Watchdog Configuration as To whole system. This instance indicates that reset system after 1s.

```
writel(0x1, WDOG_CONFIG);           //To whole system
writel(0x10, WDOG_MODE);           //Interval Value set 1s
writel(readl(WDOG_MODE)|(1<<0), WDOG_MODE); //Enable Watchdog
```

### 4.6.5.3. Watchdog Restart

In the following instance making configurations for Watchdog: configurate clock source as 24M/750, configurate Interval Value as 1s and configurate Watchdog Configuration as To whole system. In the following instance, if the time of other codes is larger than 1s, watchdog will reset the whole system. If the sentence of restart watchdog is implemented inside 1s, watchdog will be restarted.

```
writel(0x1, WDOG_CONFIG);           //To whole system
writel(0x10, WDOG_MODE);           //Interval Value set 1s
writel(readl(WDOG_MODE)|(1<<0), WDOG_MODE); //Enable Watchdog
----other codes----
writel(readl(WDOG_CTRL)|(0xA57<<1)|(1<<0), WDOG_CTRL); //Writel 0xA57 at Key Field and Restart Watchdog
```

## 4.7. Trusted Watchdog

### 4.7.1. Overview

The trusted watchdog is primarily used to protect the trusted world operations from denial of service when secure services are dependent to the RichOS scheduler. For example, if the trusted world is not entered after a defined time limit the SoC is re-started to perform an authentication of the system.

The trusted watchdog can also be used to mask the real cause of a security error thanks to the delayed warm reset it generates.

### 4.7.2. Block Diagram

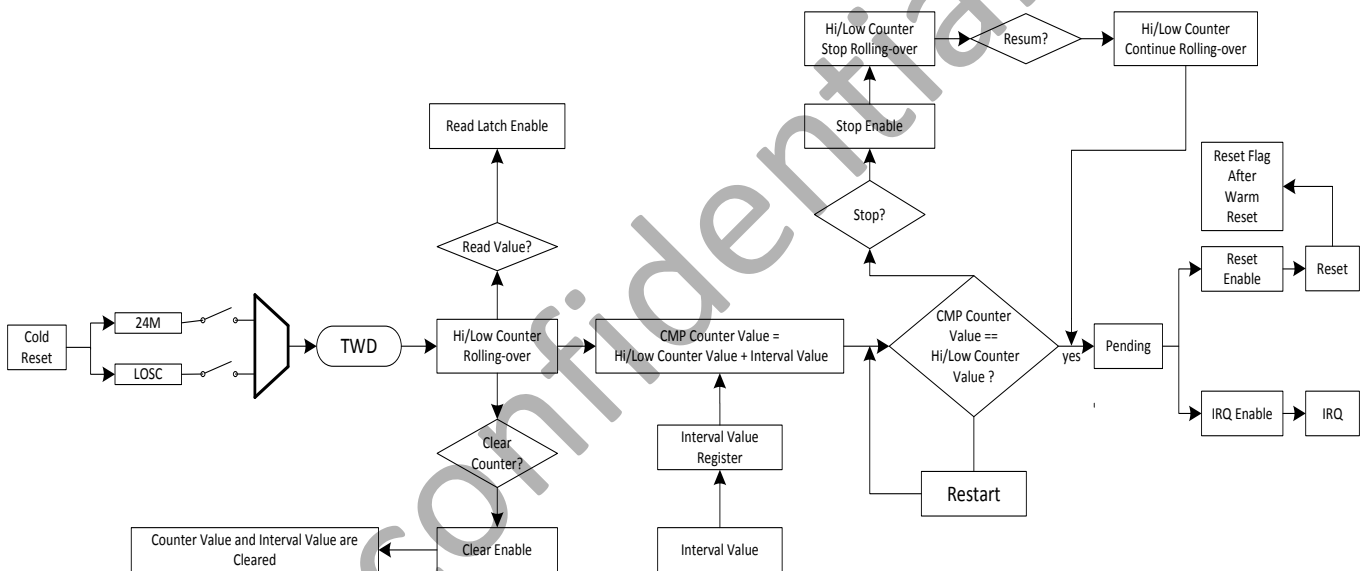

Figure 4-4. TWD Block Diagram

The trusted watchdog timer must always be running when the SoC wakes up from cold reset and can be refreshed, suspended, or reset only by secure accesses. And a clock of at least 32 kHz is used when the device is not a power saving cycles.

### 4.7.3. Functionalities Description

#### 4.7.3.1. TWD Reset

The trusted watchdog timer is able to generate a SoC warm reset after a duration programmed into the timer or set by default in hardware. And the flag indicating the occurrence of a watchdog triggered warm reset has occurred since the last cold reset.

Clock sources driving the watchdog timer must be controlled or managed by a trusted entity. This means that non-trusted world accesses are not permitted to turn on, turn off or modify the characteristics of clock source. The **Clear Enable** will reset relevant bits in the watchdog registers, except the reset flag.

#### 4.7.3.2. NV-Counter

After a firmware image is validated, the image revision number taken from the certificate extension field, for example, *Trusted Firmware NV-Counter* is compared with the corresponding NV-Counter stored in hardware. If the value is:

- Less than the associated NV-Counter, then the authentication fail.
- Identical to the NV-Counter, then the authentication is successful.
- More than the NV-Counter, then the authentication are successful and the NV-Counter is updated.

The 2<sup>32</sup> monotonic counter does not need to be e-Fuses, but it does need to be fully secure. Using the SoC embedded NVM, or external secure element, or a trusted register, which is always on power.

The **Secure Storage NV-Counter Register** is used for protecting the trusted world Secure Storage (SST) file from replay attacks, since SST contains subsidiary relay attacks protection counters for each Trusted Application.

Four 32-bit counters are used for counting 2<sup>32</sup> states for synchronizing data stores against replay attacks. These counters are optionally required since they can be handled by a Trusted OS service using the secure storage at boot time or using eMMC v4.4x Replay Protected Memory Block (RPMB).

#### 4.7.4. TWD Register List

Module Name	Base Address
TWD	0x01F01800

Register Name	Offset	Description
TWD_STATUS_REG	0x0000	TWD Status Register
TWD_CTRL_REG	0x0010	TWD Control Register
TWD_RESTART_REG	0x0014	TWD Restart Register
TWD_LOW_CNT_REG	0x0020	TWD Low Counter Register
TWD_HIGH_CNT_REG	0x0024	TWD High Counter Register
TWD_INTV_VAL_REG	0x0030	TWD Interval Value Register
TWD_LOW_CNT_CMP_REG	0x0040	TWD Low Counter Compare Register
TWD_HIGH_CNT_CMP_REG	0x0044	TWD High Counter Compare Register
SST_NV_CNT_REG	0x0100	Secure Storage NV-Counter Register
SYN_DATA_CNT_REG0	0x0110	Synchronize Data Counter Register 0
SYN_DATA_CNT_REG1	0x0114	Synchronize Data Counter Register 1
SYN_DATA_CNT_REG2	0x0118	Synchronize Data Counter Register 2
SYN_DATA_CNT_REG3	0x011C	Synchronize Data Counter Register 3

## 4.7.5. TWD Register Description

### 4.7.5.1. TWD Status Register (Default Value: 0x00000000)

Offset: 0x0000			Register Name: <b>TWD_STATUS_REG</b>
Bit	R/W	Default/Hex	Description
31:1	/	/	/
0	R/W	0x0	TWD_PEND_FLAG. Interrupt pending. Set 1 to the bit will clear it. 0: No effect. 1: Pending.

### 4.7.5.2. TWD Control Register (Default Value: 0x00000000)

Offset: 0x0010			Register Name: <b>TWD_CTRL_REG</b>
Bit	R/W	Default/Hex	Description
31	R/W	0x0	CNT64_CLK_SRC_SEL. 64-bit counter clock source select. 0: LOSC. 1: OSC24M.
30:10	/	/	/
9	R/W	0x0	TWD_RESET_EN. TWD reset enable. 0: Reset disable. 1: Reset enable.
8	R/W	0x0	TWD_INT_EN. TWD Interrupt Enable. 0: Interrupt disable. 1: Interrupt enable.
7:2	/	/	/
1	R/W	0x0	TWD_STOP_EN. TWD stop enable. 0: Resume rolling-over. 1: Stop rolling-over.
0	R/W	0x0	TWD_CLR_EN. TWD clear enable. 0: No effect. 1: To clear relevant registers and it will change to zero after the registers are cleared.

**4.7.5.3. TWD Restart Register (Default Value: 0x00000000)**

Offset: 0x0014			Register Name: <b>TWD_RESTART_REG</b>
Bit	R/W	Default/Hex	Description
31:28	/	/	/
27:16	WO	0x0	TWD_RESTART_KEYFILED. Should be written at value 0xD14. Writing any other value in this field aborts the write operation.
15:1	/	/	/
0	WO	0x0	TWD_RESTART_EN. If writing '1' in this bit, the value of <i>Counter Compare Registers</i> would change. 0: No effect. 1: Restart enable.

**4.7.5.4. TWD Low Counter Register (Default Value: 0x00000000)**

Offset: 0x0020			Register Name: <b>TWD_LOW_CNT_REG</b>
Bit	R/W	Default/Hex	Description
31:0	RO	0x0	TWD_LOW_CNT. The TWD low 32-bit counter.

**4.7.5.5. TWD High Counter Register (Default Value: 0x00000000)**

Offset: 0x0024			Register Name: <b>TWD_HIGH_CNT_REG</b>
Bit	R/W	Default/Hex	Description
31:0	RO	0x0	TWD_HIGH_CNT. The TWD high 32-bit counter.

**4.7.5.6. TWD Interval Value Register (Default Value: 0x00000000)**

Offset: 0x0030			Register Name: <b>TWD_INTV_VAL_REG</b>
Bit	R/W	Default/Hex	Description
31:0	R/W	0x0	TWD_INTV_VAL. The TWD interval value.

**4.7.5.7. TWD Low Counter Compare Register (Default Value: 0x00000000)**

Offset: 0x0040			Register Name: <b>TWD_LOW_CNT_CMP_REG</b>
----------------	--	--	---



Bit	R/W	Default/Hex	Description
31:0	RO	0x0	TWD_LOW_CMP. The TWD low 32-bit compare counter.

#### 4.7.5.8. TWD High Counter Compare Register (Default Value: 0x00000000)

Offset: 0x0044			Register Name: TWD_HIGH_CNT_CMP_REG
Bit	R/W	Default/Hex	Description
31:0	RO	0x0	TWD_HIGH_CMP. The TWD high 32-bit compare counter.

#### 4.7.5.9. Secure Storage NV-Counter Register (Default Value: 0x00000000)

Offset: 0x0100			Register Name: SST_NV_CNT_REG
Bit	R/W	Default/Hex	Description
31:0	R/W	0x0	SST_NV_CNT. This counter protects the trusted world Secure Storage file from replay attacks.

#### 4.7.5.10. Synchronize Data Counter Register 0 (Default Value: 0x00000000)

Offset: 0x0110			Register Name: SYN_DATA_CNT_REG0
Bit	R/W	Default/Hex	Description
31:0	R/W	0x0	SYN_DATA_CNT0. This counter is used for synchronizing data stores against replay attacks.

#### 4.7.5.11. Synchronize Data Counter Register 1 (Default Value: 0x00000000)

Offset: 0x0114			Register Name: SYN_DATA_CNT_REG1
Bit	R/W	Default/Hex	Description
31:0	R/W	0x0	SYN_DATA_CNT1. This counter is used for synchronizing data stores against replay attacks.

#### 4.7.5.12. Synchronize Data Counter Register 2 (Default Value: 0x00000000)

Offset: 0x0118			Register Name: SYN_DATA_CNT_REG2
Bit	R/W	Default/Hex	Description
31:0	R/W	0x0	SYN_DATA_CNT2.

			This counter is used for synchronizing data stores against replay attacks.
--	--	--	--

**4.7.5.13. Synchronize Data Counter Register 3 (Default Value: 0x00000000)**

Offset: 0x011C			Register Name: <b>SYN_DATA_CNT_REG3</b>
Bit	R/W	Default/Hex	Description
31:0	R/W	0x0	SYN_DATA_CNT3. This counter is used for synchronizing data stores against replay attacks.

Confidential

## 4.8. RTC

### 4.8.1. Overview

The real time clock (RTC) is for calendar usage. It is built around a 30-bit counter and used to count elapsed time in YY-MM-DD and HH-MM-SS. The unit can be operated by the backup battery while the system power is off. It has a built-in leap year generator and a independent power pin (RTC\_VIO).

The alarm generates an alarm signal at a specified time in the power-off mode or normal operation mode. In normal operation mode, both the alarm interrupt and the power management wakeup are activated. In power-off mode, the power management wakeup signal is activated. In this section, there are two kinds of alarm. Alarm 0 is a general alarm, its counter is based on second. Alarm 1 is a weekly alarm, its counter is based on the real time.

The 32768Hz oscillator is used only to provide a low power, accurate reference for the RTC.

General Purpose Register can be flag register, and it will save the value all the time when the VDD\_RTC is not power off.

### 4.8.2. RTC Register List

Module Name	Base Address
RTC	0x01F00000

Register Name	Offset	Description
LOSC_CTRL_REG	0x0	Low Oscillator Control Register
LOSC_AUTO_SWT_STA_REG	0x4	LOSC Auto Switch Status Register
INTOSC_CLK_PRESCAL_REG	0x8	Internal OSC Clock Prescaler Register
RTC_YY_MM_DD_REG	0x10	RTC Year-Month-Day Register
RTC_HH_MM_SS_REG	0x14	RTC Hour-Minute-Second Register
ALARM0_COUNTER_REG	0x20	Alarm 0 Counter Register
ALARM0_CUR_VLU_REG	0x24	Alarm 0 Counter Current Value Register
ALARM0_ENABLE_REG	0x28	Alarm 0 Enable Register
ALARM0_IRQ_EN	0x2C	Alarm 0 IRQ Enable Register
ALARM0_IRQ_STA_REG	0x30	Alarm 0 IRQ Status Register
ALARM1_WK_HH_MM-SS	0x40	Alarm 1 Week HMS Register
ALARM1_ENABLE_REG	0x44	Alarm 1 Enable Register
ALARM1_IRQ_EN	0x48	Alarm 1 IRQ Enable Register
ALARM1_IRQ_STA_REG	0x4C	Alarm 1 IRQ Status Register
ALARM_CONFIG_REG	0x50	Alarm Config Register
LOSC_OUT_GATING_REG	0x60	LOSC output gating register
GP_DATA_REG	0x100 + N*0x4	General Purpose Register (N=0~7)

RTC_DEB_REG	0x170	RTC Debug Register
GPL_HOLD_OUTPUT_REG	0x180	GPL Hold Output Register
VDD_RTC_REG	0x190	VDD RTC Regulate Register
IC_CHARA_REG	0x1F0	IC Characteristic Register

### 4.8.3. RTC Register Description

#### 4.8.3.1. LOSC Control Register (Default Value: 0x00004000)

Offset:0x0			Register Name: <b>LOSC_CTRL_REG</b>
Bit	R/W	Default/Hex	Description
31:16	W	0x0	KEY_FIELD. Key Field. This field should be filled with 0x16AA, and then the bit 0 can be written with the new value.
15	/	/	/
14	R/W	0x1	LOSC_AUTO_SWT_EN. LOSC auto switch enable. 0: Disable, 1: Enable.
13:10	/	/	/
9	R/W	0x0	ALM_DDHHMMSS_ACCE. ALARM DD-HH-MM-SS access. After writing the ALARM DD-HH-MM-SS register, this bit is set and it will be cleared until the real writing operation is finished.
8	R/W	0x0	RTC_HHMMSS_ACCE. RTC HH-MM-SS access. After writing the RTC HH-MM-SS register, this bit is set and it will be cleared until the real writing operation is finished. After writing the RTC YY-MM-DD register, the YY-MM-DD register will be refreshed for at most one second.
7	R/W	0x0	RTC_YMMDD_ACCE. RTC YY-MM-DD access. After writing the RTC YY-MM-DD register, this bit is set and it will be cleared until the real writing operation is finished. After writing the RTC YY-MM-DD register, the YY-MM-DD register will be refreshed for at most one second.
6:4	/	/	/
3:2	R/W	0x0	EXT_LOSC_GSM. External 32768Hz Crystal GSM. 00 low 01 10 11 high
1	/	/	/

0	R/W	0x0	<p>LOSC_SRC_SEL.</p> <p>LOSC Clock source Select. 'N' is the value of Internal OSC Clock Prescalar register.</p> <p>0: InternalOSC /32/ N, 1: External 32.768KHz OSC.</p> <p>(InternalOSC=16MHz)</p>
---	-----	-----	--

**Note1:** Any bit of [9:7] is set, the RTC HH-MM-SS, YY-MM-DD and ALARM DD-HH-MM-SS register can't be written.

**Note2:** Internal OSC is about 16MHz.

**4.8.3.2. LOSC Auto Switch Status Register (Default Value: 0x00000000)**

Offset:0x4			Register Name: <b>LOSC_AUTO_SWT_STA_REG</b>
Bit	R/W	Default/Hex	Description
31:2	/	/	/
1	R/W	0x0	<p>LOSC_AUTO_SWT_PEND.</p> <p>LOSC auto switch pending.</p> <p>0: No effect</p> <p>1: Auto switches pending</p> <p>Set 1 to this bit will clear it.</p>
0	RO	0x0	<p>LOSC_SRC_SEL_STA.</p> <p>Checking LOSC Clock Source Status. 'N' is the value of Internal OSC Clock Prescalar register.</p> <p>0: InternalOSC /32/ N</p> <p>1: External 32.768KHz OSC</p> <p>(InternalOSC=16MHz)</p>

**4.8.3.3. Internal OSC Clock Prescalar Register (Default Value: 0x0000000F)**

Offset:0x8			Register Name: <b>INTOSC_CLK_PRESCAL_REG</b>
Bit	R/W	Default/Hex	Description
31:16	/	/	/
15:0	R/W	0xF	<p>INTOSC_CLK_PRESCAL.</p> <p>Internal OSC Clock Prescalar value N.</p> <p>0x000: 1</p> <p>0x001: 2</p> <p>0x002: 3</p> <p>.....</p> <p>0x1F: 32</p>

**4.8.3.4. RTC YY-MM-DD Register (Default Value: 0x00000000)**

Offset:0x10			Register Name: <b>RTC_YY_MM_DD_REG</b>
-------------	--	--	--

Bit	R/W	Default/Hex	Description
31:23	/	/	/
22	R/W	0x0	LEAP. Leap Year. 0: not, 1: Leap year. This bit can not set by hardware. It should be set or clear by software.
21:16	R/W	x	YEAR. Year. Range from 0~63.
15:12	/	/	/
11:8	R/W	x	MONTH. Month. Range from 1~12.
7:5	/	/	/
4:0	R/W	x	DAY. Day. Range from 1~31.

**Note1:** If the written value is not from 1 to 31 in Day Area, it turns into 31 automatically. Month Area and Year Area are similar to Day Area.

**Note2:** The number of days in different month may be different.

#### 4.8.3.5. RTC HH-MM-SS Register (Default Value: 0x00000000)

Offset:0x14			Register Name: <b>RTC_HH_MM_SS_REG</b>
Bit	R/W	Default/Hex	Description
31:29	R/W	0x0	WK_NO. Week number. 000: Monday 001: Tuesday 010: Wednesday 011: Thursday 100: Friday 101: Saturday 110: Sunday 111: /
28:21	/	/	/
20:16	R/W	x	HOUR. Range from 0~23
15:14	/	/	/
13:8	R/W	x	MINUTE. Range from 0~59
7:6	/	/	/
5:0	R/W	x	SECOND. Range from 0~59

**Note:** If the written value is not from 0 to 59 in Second Area, it turns into 59 automatically. Minute Area and Hour Area are similar to Second Area.

**4.8.3.6. Alarm 0 Counter Register (Default Value: 0x00000000)**

Offset:0x20			Register Name: <b>ALARM0_COUNTER_REG</b>
Bit	R/W	Default/Hex	Description
31:0	R/W	0x0	ALARM0_COUNTER. Alarm 0 Counter is Based on Second.

**Note:** If the second is set to 0, it will be 1 second in fact.

**4.8.3.7. Alarm 0 Current Value Register**

Offset:0x24			Register Name: <b>ALARM0_CUR_VLU_REG</b>
Bit	R/W	Default/Hex	Description
31:0	RO	x	ALARM0_CUR_VLU. Check Alarm 0 Counter Current Values.

**Note:** If the second is set to 0, it will be 1 second in fact.

**4.8.3.8. Alarm 0 Enable Register (Default Value: 0x00000000)**

Offset:0x28			Register Name: <b>ALARM0_ENABLE_REG</b>
Bit	R/W	Default/Hex	Description
31:1	/	/	/
0	R/W	0x0	ALM_0_EN Alarm 0 Enable. If this bit is set to "1", the Alarm 0 Counter register's valid bits will down count to zero, and the alarm pending bit will be set to "1". 0: Disable 1: Enable

**4.8.3.9. Alarm 0 IRQ Enable Register (Default Value: 0x00000000)**

Offset:0x2C			Register Name: <b>ALARM0_IRQ_EN</b>
Bit	R/W	Default/Hex	Description
31:1	/	/	/
0	R/W	0x0	ALARM0_IRQ_EN.

			Alarm 0 IRQ Enable. 0: Disable 1: Enable
--	--	--	--

#### 4.8.3.10. Alarm 0 IRQ Status Register (Default Value: 0x00000000)

Offset:0x30			Register Name: <b>ALARM0_IRQ_STA_REG</b>
Bit	R/W	Default/Hex	Description
31:1	/	/	/
0	R/W	0x0	ALARM0_IRQ_PEND. Alarm 0 IRQ Pending bit. 0: No effect 1: Pending, alarm 0 counter value is reached If alarm 0 irq enable is set to 1, the pending bit will be sent to the interrupt controller.

#### 4.8.3.11. Alarm 1 Week HH-MM-SS Register (Default Value: 0x00000000)

Offset:0x40			Register Name: <b>ALARM1_WK_HH_MM-SS</b>
Bit	R/W	Default/Hex	Description
31:21	/	/	/
20:16	R/W	x	HOUR. Range from 0~23.
15:14	/	/	/
13:8	R/W	x	MINUTE. Range from 0~59.
7:6	/	/	/
5:0	R/W	x	SECOND. Range from 0~59.

**Note:** If the written value is not from 0 to 59 in Second Area, it turns into 59 automatically. Minute Area and Hour Area are similar to Second Area.

#### 4.8.3.12. Alarm 1 Enable Register (Default Value: 0x00000000)

Offset:0x44			Register Name: <b>ALARM1_EN_REG</b>
Bit	R/W	Default/Hex	Description
31:7	/	/	/
6	R/W	0x0	WK6_ALM1_EN. Week 6 (Sunday) Alarm 1 Enable. 0: Disable



			<p>1: Enable</p> <p>If this bit is set to “1”, only when the Alarm 1 Week HH-MM-SS register valid bits is equal to RTC HH-MM-SS register and the register RTC HH-MM-SS bit [31:29] is 6, the week 6 alarm irq pending bit will be set to “1”.</p>
5	R/W	0x0	<p>WK5_ALM1_EN.</p> <p>Week 5 (Saturday) Alarm 1 Enable.</p> <p>0: Disable</p> <p>1: Enable</p> <p>If this bit is set to “1”, only when the Alarm 1 Week HH-MM-SS register valid bits is equal to RTC HH-MM-SS register and the register RTC HH-MM-SS bit [31:29] is 5, the week 5 alarm irq pending bit will be set to “1”.</p>
4	R/W	0x0	<p>WK4_ALM1_EN.</p> <p>Week 4 (Friday) Alarm 1 Enable.</p> <p>0: Disable</p> <p>1: Enable</p> <p>If this bit is set to “1”, only when the Alarm 1 Week HH-MM-SS register valid bits is equal to RTC HH-MM-SS register and the register RTC HH-MM-SS bit [31:29] is 4, the week 4 alarm irq pending bit will be set to “1”.</p>
3	R/W	0x0	<p>WK3_ALM1_EN.</p> <p>Week 3 (Thursday) Alarm 1 Enable.</p> <p>0: Disable</p> <p>1: Enable</p> <p>If this bit is set to “1”, only when the Alarm 1 Week HH-MM-SS register valid bits is equal to RTC HH-MM-SS register and the register RTC HH-MM-SS bit [31:29] is 3, the week 3 alarm irq pending bit will be set to “1”.</p>
2	R/W	0x0	<p>WK2_ALM1_EN.</p> <p>Week 2 (Wednesday) Alarm 1 Enable.</p> <p>0: Disable</p> <p>1: Enable</p> <p>If this bit is set to “1”, only when the Alarm 1 Week HH-MM-SS register valid bits is equal to RTC HH-MM-SS register and the register RTC HH-MM-SS bit [31:29] is 2, the week 2 alarm irq pending bit will be set to “1”.</p>
1	R/W	0x0	<p>WK1_ALM1_EN.</p> <p>Week 1 (Tuesday) Alarm 1 Enable.</p> <p>0: Disable</p> <p>1: Enable</p> <p>If this bit is set to “1”, only when the Alarm 1 Week HH-MM-SS register valid bits is equal to RTC HH-MM-SS register and the register RTC HH-MM-SS bit [31:29] is 1, the week 1 alarm irq pending bit will be set to “1”.</p>
0	R/W	0x0	<p>WK0_ALM1_EN.</p> <p>Week 0 (Monday) Alarm 1 Enable.</p> <p>0: Disable</p> <p>1: Enable</p> <p>If this bit is set to “1”, only when the Alarm 1 Week HH-MM-SS register valid bits is equal to RTC HH-MM-SS register and the register RTC HH-MM-SS bit</p>

			[31:29] is 0, the week 0 alarm irq pending bit will be set to "1".
--	--	--	--

**4.8.3.13. Alarm 1 IRQ Enable Register (Default Value: 0x00000000)**

Offset:0x48			Register Name: <b>ALARM1_IRQ_EN</b>
Bit	R/W	Default/Hex	Description
31:1	/	/	/
0	R/W	0x0	ALARM1_IRQ_EN. Alarm 1 IRQ Enable. 0: Disable 1: Enable

**4.8.3.14. Alarm 1 IRQ Status Register (Default Value: 0x00000000)**

Offset:0x4C			Register Name: <b>ALARM1_IRQ_STA_REG</b>
Bit	R/W	Default/Hex	Description
31:1	/	/	/
0	R/W	0x0	ALARM1_WEEK_IRQ_PEND. Alarm 1 Week (0/1/2/3/4/5/6) IRQ Pending. 0: No effect 1: Pending, week counter value is reached If alarm 1 week irq enable is set to 1, the pending bit will be sent to the interrupt controller.

**4.8.3.15. Alarm Config Register (Default Value: 0x00000000)**

Offset:0x50			Register Name: <b>ALARM_CONFIG_REG</b>
Bit	R/W	Default/Hex	Description
31:1	/	/	/
0	R/W	0x0	ALARM_WAKEUP. Configuration of alarm wake up output. 0: Disable alarm wake up output 1: Enable alarm wake up output

**4.8.3.16. LOSC Output Gating Register (Default Value: 0x00000000)**

Offset:0x60			Register Name: <b>LOSC_OUT_GATING_REG</b>
Bit	R/W	Default/Hex	Description
31:1	/	/	/

0	R/W	0x0	<p>LOSC_OUT_GATING.</p> <p>Configuration of LOSC output, and no LOSC output by default.</p> <p>0: Enable LOSC output gating 1: Disable LOSC output gating</p>
---	-----	-----	---

**4.8.3.17. General Purpose Register (Default Value: 0x00000000)**

Offset:0x100+N *0x4 (N=0~7)			Register Name: GP_DATA_REGn
Bit	R/W	Default/Hex	Description
31:0	R/W	0x0	GP_DATA. Data [31:0].

**Note:** general purpose register 0~7 value can be stored if the VDD\_RTC is larger than 1.0v.

**4.8.3.18. RTC Debug Register (Default Value: 0x00000000)**

Offset:0x170			Register Name: RTC_DEB_REG
Bit	R/W	Default/Hex	Description
31:2	/	/	/
1	R/W	0x0	RTC_TEST_MODE_CTRL. RTC TEST Mode Control bit.
0	R/W	0x0	RTC_DEBUG. RTC Simulation Control bit 0: No effect. 1: simulation mode

**4.8.3.19. GPL Hold Output Register (Default Value: 0x00000000)**

Offset:0x180			Register Name: GPL_HOLD_OUTPUT_REG
Bit	R/W	Default/Hex	Description
31:12	/	/	/
11	R/W	0x0	GPL11_HOLD_OUTPUT. Hold the output of GPIOL11 when system's power is changing. The output must be low level (0) or high level (1) or High-Z; any other outputs may not hold on. 0: Hold disable 1: Hold enable
10	R/W	0x0	GPL10_HOLD_OUTPUT. Hold the output of GPIOL10 when system's power is changing. The output must be low level (0) or high level (1) or High-Z; any other outputs may not hold on.

			0: Hold disable 1: Hold enable
9	R/W	0x0	GPL9_HOLD_OUTPUT. Hold the output of GPIO9 when system's power is changing. The output must be low level (0) or high level (1) or High-Z; any other outputs may not hold on. 0: Hold disable 1: Hold enable
8	R/W	0x0	GPL8_HOLD_OUTPUT. Hold the output of GPIO8 when system's power is changing. The output must be low level (0) or high level (1) or High-Z; any other outputs may not hold on. 0: Hold disable 1: Hold enable
7	R/W	0x0	GPL7_HOLD_OUTPUT. Hold the output of GPIO7 when system's power is changing. The output must be low level (0) or high level (1) or High-Z; any other outputs may not hold on. 0: Hold disable 1: Hold enable
6	R/W	0x0	GPL6_HOLD_OUTPUT. Hold the output of GPIO6 when system's power is changing. The output must be low level (0) or high level (1) or High-Z; any other outputs may not hold on. 0: Hold disable 1: Hold enable
5	R/W	0x0	GPL5_HOLD_OUTPUT. Hold the output of GPIO5 when system's power is changing. The output must be low level (0) or high level (1) or High-Z; any other outputs may not hold on. 0: Hold disable 1: Hold enable
4	R/W	0x0	GPL4_HOLD_OUTPUT. Hold the output of GPIO4 when system's power is changing. The outputs must be low level (0) or high level (1) or High-Z; any other output may not hold on. 0: Hold disable 1: Hold enable
3	R/W	0x0	GPL3_HOLD_OUTPUT. Hold the output of GPIO3 when system's power is changing. The output must be low level (0) or high level (1) or High-Z; any other outputs may not hold on. 0: Hold disable 1: Hold enable
2	R/W	0x0	GPL2_HOLD_OUTPUT.

			Hold the output of GPIOL2 when system's power is changing. The output must be low level (0) or high level (1) or High-Z; any other outputs may not hold on. 0: Hold disable 1: Hold enable
1	R/W	0x0	GPL1_HOLD_OUTPUT. Hold the output of GPIOL1 when system's power is changing. The output must be low level (0) or high level (1) or High-Z; any other outputs may not hold on. 0: Hold disable 1: Hold enable
0	R/W	0x0	GPL0_HOLD_OUTPUT. Hold the output of GPIOL0 when system's power is changing. The output must be low level (0) or high level (1) or High-Z; any other outputs may not hold on. 0: Hold disable 1: Hold enable

#### 4.8.3.20. VDD RTC Regulation Register (Default Value: 0x00000004)

Offset:0x190			Register Name: <b>VDD_RTC_REG</b>
Bit	R/W	Default/Hex	Description
31:3	/	/	/
2:0	R/W	0x100	VDD_RTC_REGU. These bits are useful for regulating the RTC_VIO from 0.7v to 1.4v, and the regulation step is 0.1v. 000: 0.7v 001: 0.8v 010: 0.9v 011: 1.0v 100: 1.1v 101: 1.2v 110: 1.3v 111: 1.4v

#### 4.8.3.21. IC Characteristic Register (Default Value: 0x00000000)

Offset:0x1F0			Register Name: <b>IC_CHARA_REG</b>
Bit	Read/Write	Default/Hex	Description
31:16	R/W	0x0	IC_CHARA. Key Field. Should be written at value 0x16AA. Writing any other value in this field

			aborts the write operation.
15:0	R/W	0x0	ID_DATA. Return 0x16aa only if the KEY_FIELD is set as 0x16aa when read those bits, otherwise return 0x0.

Confidential

## 4.9. High-speed Timer

### 4.9.1. Overview

High Speed Timer Clock Source are fixed to AHBCLK, which is much higher than OSC24M. Compared with other timers, High Speed Timer clock source is synchronized with AHB clock, and when the relevant bit in the Control Register is set 1, timer goes into the test mode, which is used to System Simulation. When the current value in both LO and HI Current Value Register are counting down to zero, the timer will generate interrupt if set interrupt enable bit.

The High Speed Timer includes the following features:

- 56-bit counter
- Clock source is synchronized with AHB clock, which means calculating much more accurate than other timers

### 4.9.2. Operation Principle

#### 4.9.2.1. HSTimer clock gating and software reset

By default the HSTimer clock gating is mask. When it is necessary to use HSTimer, it's clock gating should be open in **BUS Clock Gating Register0** and then de-assert the software reset in **BUS Software Reset Register0** on CCU module. If it is no need to use HSTimer, both the gating bit and software reset bit should be set 0.

#### 4.9.2.2. HSTimer reload bit

Differing from the reload of Timer, when interval value is reloaded into current value register, the reload bit would not turn to 0 automatically until you clear it. If software hopes the current value register to down-count from the new interval value in pause status, the reload bit and the enable bit should be written 1 at the same time.

### 4.9.3. HSTimer Register List

Module Name	Base Address
High Speed Timer	0x01C60000

Register Name	Offset	Description
HS_TMR_IRQ_EN_REG	0x00	HS Timer IRQ Enable Register
HS_TMR_IRQ_STAS_REG	0x04	HS Timer Status Register

HS_TMR_CTRL_REG	0x10	HS Timer Control Register
HS_TMR_INTV_LO_REG	0x14	HS Timer Interval Value Low Register
HS_TMR_INTV_HI_REG	0x18	HS Timer Interval Value High Register
HS_TMR_CURNT_LO_REG	0x1C	HS Timer Current Value Low Register
HS_TMR_CURNT_HI_REG	0x20	HS Timer Current Value High Register

#### 4.9.4. HSTimer Register Description

##### 4.9.4.1. HS Timer IRQ Enable Register (Default Value: 0x00000000)

Offset:0x0			Register Name: <b>HS_TMR_IRQ_EN_REG</b>
Bit	R/W	Default/Hex	Description
31:1	/	/	/
0	R/W	0x0	HS_TMR_INT_EN. High Speed Timer Interrupt Enable. 0: No effect; 1: High Speed Timer Interval Value reached interrupt enable.

##### 4.9.4.2. HS Timer IRQ Status Register (Default Value: 0x00000000)

Offset:0x4			Register Name: <b>HS_TMR_IRQ_STAS_REG</b>
Bit	R/W	Default/Hex	Description
31:1	/	/	/
0	R/W	0x0	HS_TMR_IRQ_PEND. High Speed Timer IRQ Pending. Set 1 to the bit will clear it. 0: No effect; 1: Pending, High speed timer interval value is reached.

##### 4.9.4.3. HS Timer Control Register (Default Value: 0x00000000)

Offset:0x10			Register Name: <b>HS_TMR_CTRL_REG</b>
Bit	R/W	Default/Hex	Description
31	R/W	0x0	HS_TMR_TEST. High speed timer test mode. In test mode, the low register should be set to 0x1, the high register will down counter. The counter needs to be reloaded. 0: normal mode; 1: test mode.
30:8	/	/	/
7	R/W	0x0	HS_TMR_MODE. High Speed Timer mode. 0: Continuous mode. When interval value reached, the timer will not disable



			<p>automatically.</p> <p>1: Single mode. When interval value reached, the timer will disable automatically.</p>
6:4	R/W	0x0	<p>HS_TMR_CLK</p> <p>Select the pre-scale of the high speed timer clock sources.</p> <p>000: /1 001: /2 010: /4 011: /8 100: /16 101: / 110: / 111: /</p>
3:2	/	/	/
1	R/W	0x0	<p>HS_TMR_RELOAD.</p> <p>High Speed Timer Reload.</p> <p>0: No effect, 1: Reload High Speed Timer Interval Value.</p>
0	R/W	0x0	<p>HS_TMR_EN.</p> <p>High Speed Timer Enable.</p> <p>0: Stop/Pause, 1: Start.</p> <p>If the timer is started, it will reload the interval value to internal register, and the current counter will count from interval value to 0.</p> <p>If the current counter does not reach the zero, the timer enable bit is set to "0", the current value counter will pause. At least wait for 2 cycles, the start bit can be set to 1.</p> <p>In timer pause state, the interval value register can be modified. If the timer is started again, and the Software hope the current value register to down-count from the new interval value, the reload bit and the enable bit should be set to 1 at the same time.</p>

#### 4.9.4.4. HS Timer Interval Value Lo Register

Offset:0x14			Register Name: <b>HS_TMR_INTV_LO_REG</b>
Bit	R/W	Default/Hex	Description
31:0	R/W	x	<p>HS_TMR_INTV_VALUE_LO.</p> <p>High Speed Timer Interval Value [31:0].</p>

#### 4.9.4.5. HS Timer Interval Value Hi Register

Offset:0x18			Register Name: <b>HS_TMR_INTV_HI_REG</b>
Bit	R/W	Default/Hex	Description
31:24	/	/	/
23:0	R/W	x	HS_TMR_INTV_VALUE_HI.

			High Speed Timer Interval Value [55:32].
--	--	--	--

**Note:**The interval value register is a 56-bit register. When read or write the interval value, the Lo register should be read or write first. And the Hi register should be written after the Lo register.

**4.9.4.6. HS Timer Current Value Lo Register**

Offset:0x1C			Register Name: <b>HS_TMR_CURNT_LO_REG</b>
Bit	R/W	Default/Hex	Description
31:0	R/W	x	HS_TMR_CUR_VALUE_LO. High Speed Timer Current Value [31:0].

**4.9.4.7. HS Timer Current Value Hi Register**

Offset:0x20			Register Name: <b>HS_TMR_CURNT_HI_REG</b>
Bit	R/W	Default/Hex	Description
31:24	/	/	/
23:0	R/W	x	HS_TMR_CUR_VALUE_HI. High Speed Timer Current Value [55:32].

**Note1:**HStimer current value is a 56-bit down-counter (from interval value to 0).

**Note2:**The current value register is a 56-bit register. When read or write the current value, the Lo register should be read or write first.

**4.9.5. Programming Guidelines**

Take making a 1us delay using HStimer for an instance as follow, AHB1CLK will be configured as 100MHz and n\_mode, Single mode and 2 pre-scale will be selected in this instance.

```
writel(0x0, HS_TMR_INTV_HI); //Set interval value Hi 0x0
writel(0x32, HS_TMR_INTV_LO); //Set interval value Lo 0x32
writel(0x90, HS_TMR_CTRL); //Select n_mode,2 pre-scale,single mode
writel(readl(HS_TMR_CTRL)|(1<<1), HS_TMR_CTRL); //Set Reload bit
writel(readl(HS_TMR_CTRL)|(1<<0), HS_TMR_CTRL); //Enable HStimer
While(!(readl(HS_TMR_IRQ_STAT)&1)); //Wait for HStimer to generate pending
Writel(1,HS_TMR_IRQ_STAT); //Clear HStimer pending
```

## 4.10. PWM

### 4.10.1. Overview

The output of the PWM is a toggling signal whose frequency and duty cycle can be modulated by its programmable registers. Each channel has a dedicated internal 16-bit up counter. If the counter reaches the value stored in the channel period register, it resets. At the beginning of a count period cycle, the PWMOUT is set to active state and count from 0x0000. The PWM divider divides the clock (24MHz) by 1~4096 according to the pre-scalar bits in the PWM control register.

In PWM cycle mode, the output will be a square waveform, the frequency is set to the period register. In PWM pulse mode, the output will be a positive pulse or a negative pulse.

### 4.10.2. PWM Block Diagram

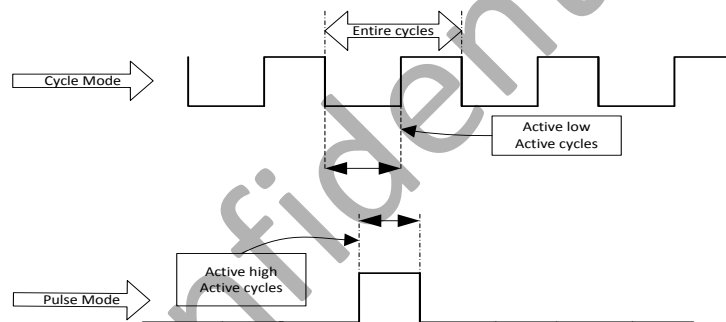

Figure 4-5. PWM Block Diagram

When PWM is enabling, the PWM can output two signals, which are reversed on two pins. And when PWM is disabling, the PWM can control the status of two pins. The PWM divider divides the clock (24MHz) by 1-64 according to the pre-scalar bits in the PWM control register. The PWM output Frequency can be divided by 65536 at most. In PWM cycle mode, the output will be a square waveform; the frequency is set to the period register. In PWM pulse mode, the output will be a positive pulse or a negative pulse.

### 4.10.3. PWM Register List

Module Name	Base Address
PWM	0x01C21400

Register Name	Offset	Description
PWM_CH_CTRL	0x00	PWM Control Register
PWM_CH0_PERIOD	0x04	PWM Channel 0 Period Register

PWM_CH1_PERIOD	0x08	PWM Channel 1 Period Register
----------------	------	-------------------------------

#### 4.10.4. PWM Register Description

##### 4.10.4.1. PWM Control Register(Default Value: 0x00000000)

Offset:0x0			Register Name: <b>PWM_CTRL_REG</b>
Bit	R/W	Default/Hex	Description
31:30	/	/	/.
29	RO	0x0	PWM1_RDY. PWM1 period register ready. 0: PWM1 period register is ready to write, 1: PWM1 period register is busy.
28	RO	0x0	PWM0_RDY. PWM0 period register ready. 0: PWM0 period register is ready to write, 1: PWM0 period register is busy.
27:25	/	/	/
24	R/W	0x0	PWM1_BYPASS. PWM CH1 bypass enable. If the bit is set to 1, PWM1's output is OSC24MHz. 0: disable 1: enable
23	R/W	0x0	PWM_CH1_PULSE_OUT_START. PWM Channel 1 pulse output start. 0: no effect, 1: output 1 pulse. The pulse width should be according to the period 1 register[15:0],and the pulse state should be according to the active state. After the pulse is finished,the bit will be cleared automatically.
22	R/W	0x0	PWM_CH1_MODE. PWM Channel 1 mode. 0: cycle mode, 1: pulse mode.
21	R/W	0x0	PWM_CH1_CLK_GATING Gating the Special Clock for PWM1(0: mask, 1: pass).
20	R/W	0x0	PWM_CH1_ACT_STATE. PWM Channel 1 Active State. 0: Low Level, 1: High Level.
19	R/W	0x0	PWM_CH1_EN. PWM Channel 1 Enable. 0: Disable,

			1: Enable.
18:15	R/W	0x0	<p>PWM_CH1_PRESCAL. PWM Channel 1 Prescaler.</p> <p>These bits should be setting before the PWM Channel 1 clock gate on.</p> <p>0000: /120 0001: /180 0010: /240 0011: /360 0100: /480 0101: / 0110: / 0111: / 1000: /12k 1001: /24k 1010: /36k 1011: /48k 1100: /72k 1101: / 1110: / 1111: /1</p>
14:10	/	/	/
9	R/W	0x0	<p>PWM0_BYPASS. PWM CH0 bypass enable.</p> <p>If the bit is set to 1, PWM0's output is OSC24MHz.</p> <p>0: disable, 1: enable.</p>
8	R/W	0x0	<p>PWM_CH0_PUL_START. PWM Channel 0 pulse output start.</p> <p>0: no effect, 1: output 1 pulse.</p> <p>The pulse width should be according to the period 0 register[15:0],and the pulse state should be according to the active state. After the pulse is finished,the bit will be cleared automatically.</p>
7	R/W	0x0	<p>PWM_CHANNELO_MODE. 0: cycle mode, 1: pulse mode.</p>
6	R/W	0x0	<p>SCLK_CH0_GATING. Gating the Special Clock for PWM0(0: mask, 1: pass).</p>
5	R/W	0x0	<p>PWM_CH0_ACT_STA. PWM Channel 0 Active State.</p> <p>0: Low Level, 1: High Level.</p>
4	R/W	0x0	<p>PWM_CH0_EN. PWM Channel 0 Enable.</p> <p>0: Disable,</p>

			1: Enable.
3:0	R/W	0x0	<p>PWM_CHO_PRESCAL. PWM Channel 0 Prescaler.</p> <p>These bits should be setting before the PWM Channel 0 clock gate on.</p> <p>0000: /120 0001: /180 0010: /240 0011: /360 0100: /480 0101: / 0110: / 0111: / 1000: /12k 1001: /24k 1010: /36k 1011: /48k 1100: /72k 1101: / 1110: / 1111: /1</p>

**4.10.4.2. PWM Channel 0 Period Register(Default Value: 0x00000000)**

Offset:0x4			Register Name: PWM_CHO_PERIOD
Bit	R/W	Default/Hex	Description
31:16	R/W	x	<p>PWM_CHO_ENTIRE_CYS Number of the entire cycles in the PWM clock.</p> <p>0 = 1 cycle 1 = 2 cycles ..... N = N+1 cycles</p> <p>If the register need to be modified dynamically, the PCLK should be faster than the PWM CLK (PWM CLK = 24MHz/pre-scale).</p>
15:0	R/W	x	<p>PWM_CHO_ENTIRE_ACT_CYS Number of the active cycles in the PWM clock.</p> <p>0 = 0 cycle 1 = 1 cycles ..... N = N cycles</p>

**Note:**The active cycles should be no larger than the period cycles.

**4.10.4.3. PWM Channel 1 Period Register**

Offset:0x8			Register Name: <b>PWM_CH1_PERIOD</b>
Bit	R/W	Default/Hex	Description
31:16	R/W	x	<b>PWM_CH1_ENTIRE_CYS</b> Number of the entire cycles in the PWM clock. 0 = 1 cycle 1 = 2 cycles ..... N = N+1 cycles If the register need to be modified dynamically, the PCLK should be faster than the PWM CLK (PWM CLK = 24MHz/pre-scale).
15:0	R/W	x	<b>PWM_CH1_ENTIRE_ACT_CYS</b> Number of the active cycles in the PWM clock. 0 = 0 cycle 1 = 1 cycles ..... N = N cycles

**Note:**The active cycles should be no larger than the period cycles.

Confidential

## 4.11. DMA

### 4.11.1. Overview

There are 12 DMA channels in the chip. Each DMA channel can generate interrupts. According to different pending status, the referenced DMA channel generates corresponding interrupt. And, the configuration information of every DMA channel are storing in the DDR or SRAM. When start a DMA transferring, the **DMA Channel Descriptor Address Register** contains the address information in the DDR or SRAM, where has the relevance configuration information of the DMA transferring.

### 4.11.2. Functionalities Description

#### 4.11.2.1. Block Diagram

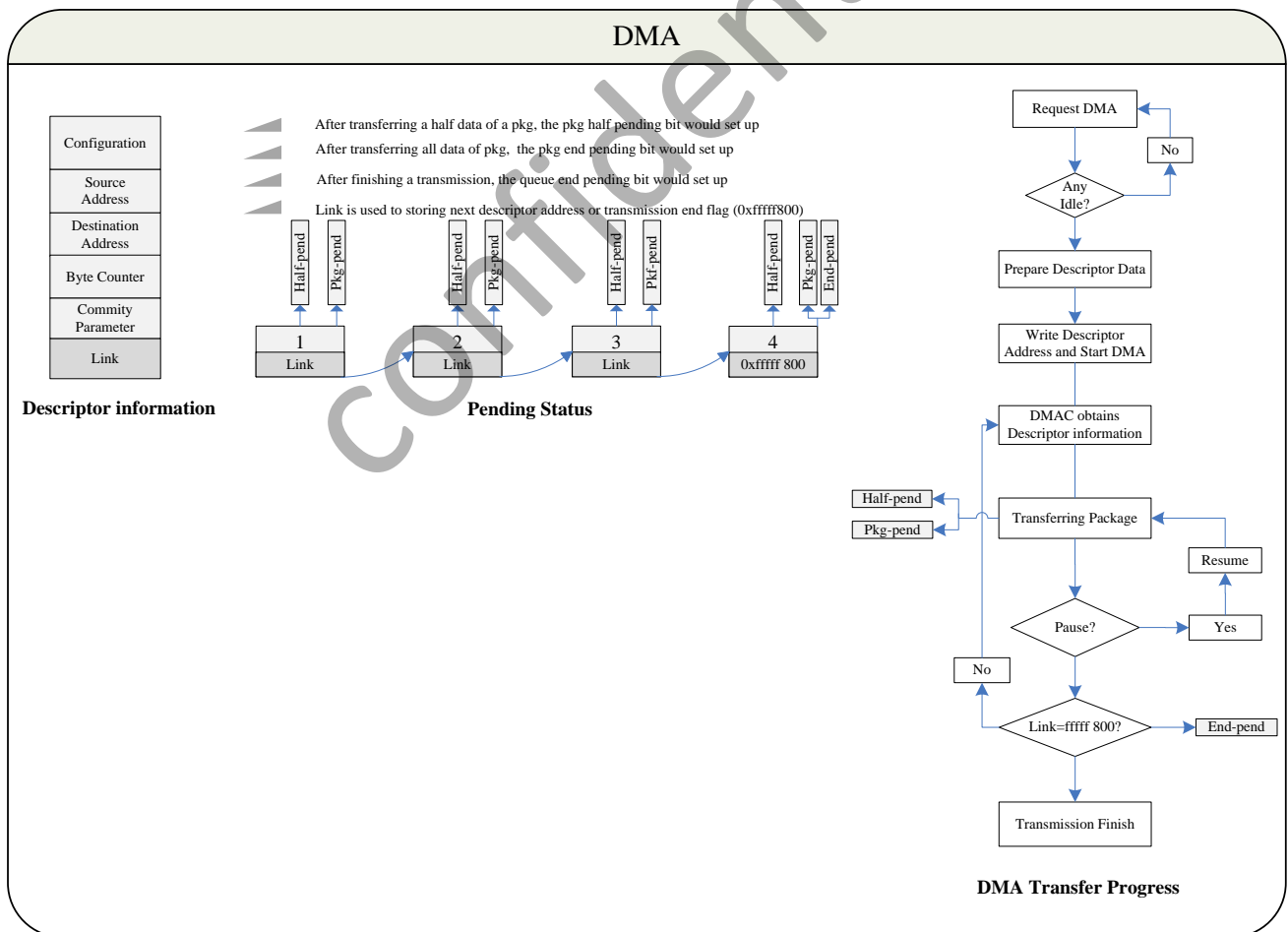

Figure 4-6. DMA Block Diagram



4.11.2.2. DRQ Type and Corresponding Relation

Table 4-1. DMA DRQ Table

Source DRQ Type		Destination DRQ Type	
Port NO.	Module Name	Port NO.	Module Name
Port 0	SRAM	Port 0	SRAM
Port 1	SDRAM	Port 1	SDRAM
Port 2	/	Port 2	OWA_TX
Port 3	I2S/PCM 0_RX	Port 3	I2S/PCM 0_TX
Port 4	I2S/PCM 1_RX	Port 4	I2S/PCM 1_TX
Port 5	NAND	Port 5	NAND
Port 6	UART0_RX	Port 6	UART0_TX
Port 7	UART1_RX	Port 7	UART1_TX
Port 8	UART2_RX	Port 8	UART2_TX
Port 9	UART3_RX	Port 9	UART3_TX
Port 10	/	Port 10	/
Port 11	/	Port 11	/
Port 12	/	Port 12	/
Port 13	/	Port 13	/
Port 14	/	Port 14	/
Port 15	Audio Codec	Port 15	Audio Codec
Port 16	/	Port 16	/
Port 17	USB OTG_Device_EP1	Port 17	USB OTG_Device_EP1
Port 18	USB OTG_Device_EP2	Port 18	USB OTG_Device_EP2
Port 19	USB OTG_Device_EP3	Port 19	USB OTG_Device_EP3
Port20	USB OTG_Device_EP4	Port 20	USB OTG_Device_EP4
Port 21	/	Port 21	/
Port 22	/	Port 22	/
Port 23	SPI0_RX	Port 23	SPI0_TX
Port 24	SPI1_RX	Port 24	SPI1_TX
Port 25		Port 25	
Port 26		Port 26	
Port 27		Port 27	I2S/PCM 2_TX
Port 28		Port 28	
Port 29		Port 29	
Port 30		Port 30	

**Note:**SRAM or DRAM DRQ signal is always high.

4.11.2.3. DMA Descriptor

In this section, the DMA descriptor registers will be introduced in detail.

When starting a DMA transmission, the module data are transferred as packages, which have the link data information.

And, by reading the DMA Status Register, the status of a DMA channel could be known. Reading back the descriptor address register, the value is the link data in the transferring package. If only the value is equal to 0xffff800, then it can be regarded as NULL, which means the package is the last package in this DMA transmission. Otherwise, the value means the start address of the next package. And, the Descriptor Address Register can be changed during a package transferring.

When transferring the half of a package, the relevant pending bit will be set up automatically, and if the corresponding interrupt is enabled, DMA generates an interrupt to the system. The similar thing would occur when transferring a package completely. Meanwhile, if DMA have transferred the last package in the data, the relevant pending bit would be set up, and generates an interrupt if the corresponding interrupt is enabled. The flow-process diagram is showed in Block Diagram section.

During a DMA transmission, the configuration could be obtained via the Configuration Register. And, behind the address of the config register in DDR or SRAM, there are some registers including other information of a DMA transmission. The structure chart is showed in Block Diagram section. Also, other information of a transferring data can be obtained by reading the Current Source Address Register, Current Destination Address Register and Byte Counter Left Register. The configuration must be word-aligning.

The transferring data would be paused when setting up the relevant Pause Register, if coming up emergency. And the pausing data could be presumable when set 0 to the same bit in Pause Register.

### 4.11.3. DMA Register List

Module Name	Base Address
DMA	0x01C02000

Register Name	Offset	Description
DMA_IRQ_EN_REG0	0x00	DMA IRQ Enable Register0
DMA_IRQ_EN_REG1	0x04	DMA IRQ Enable Register1
DMA_IRQ_PEND_REG0	0x10	DMA IRQ Pending Register0
DMA_IRQ_PEND_REG1	0x14	DMA IRQ Pending Register1
DMA_SEC_REG	0x20	DMA Security Register
DMA_AUTO_GATE_REG	0x28	DMA Auto Gating Register
DMA_STA_REG	0x30	DMA Status Register
DMA_EN_REG	0x100+N*0x40	DMA Channel Enable Register (N=0~11)
DMA_PAU_REG	0x100+N*0x40+0x4	DMA Channel Pause Register (N=0~11)
DMA_DESC_ADDR_REG	0x100+N*0x40+0x8	DMA Channel Start Address Register (N=0~11)
DMA_CFG_REG	0x100+N*0x40+0xC	DMA Channel Configuration Register (N=0~11)
DMA_CUR_SRC_REG	0x100+N*0x40+0x10	DMA Channel Current Source Register (N=0~11)

DMA_CUR_DEST_REG	0x100+N*0x40+0x14	DMA Channel Current Destination Register (N=0~11)
DMA_BCNT_LEFT_REG	0x100+N*0x40+0x18	DMA Channel Byte Counter Left Register (N=0~11)
DMA_PARA_REG	0x100+N*0x40+0x1C	DMA Channel Parameter Register (N=0~11)
DMA_FDESC_ADDR_REG	0x100+N*0x40+0x2C	DMA Formar Descriptor Address Register (N=0~11)
DMA_PKG_NUM_REG	0x100+N*0x40+0x30	DMA Package Number Register (N=0~11)

#### 4.11.4. DMA Register Description

##### 4.11.4.1. DMA IRQ Enable Register0 (Default Value: 0x00000000)

Offset: 0x0000			Register Name: <b>DMA_IRQ_EN_REG0</b>
Bit	R/W	Default/Hex	Description
31	/	/	/
30	R/W	0x0	DMA7_QUEUE_IRQ_EN DMA 7 Queue End Transfer Interrupt Enable. 0: Disable, 1: Enable.
29	R/W	0x0	DMA7_PKG_IRQ_EN DMA 7 Package End Transfer Interrupt Enable. 0: Disable, 1: Enable.
28	R/W	0x0	DMA7_HLAF_IRQ_EN DMA 7 Half Package Transfer Interrupt Enable. 0: Disable, 1: Enable.
27	/	/	/
26	R/W	0x0	DMA6_QUEUE_IRQ_EN DMA 6 Queue End Transfer Interrupt Enable. 0: Disable, 1: Enable.
25	R/W	0x0	DMA6_PKG_IRQ_EN DMA 6 Package End Transfer Interrupt Enable. 0: Disable, 1: Enable.
24	R/W	0x0	DMA6_HLAF_IRQ_EN DMA 6 Half Package Transfer Interrupt Enable. 0: Disable, 1: Enable.
23	/	/	/
22	R/W	0x0	DMA5_QUEUE_IRQ_EN DMA 5 Queue End Transfer Interrupt Enable. 0: Disable, 1: Enable.
21	R/W	0x0	DMA5_PKG_IRQ_EN

			DMA 5 Package End Transfer Interrupt Enable. 0: Disable, 1: Enable.
20	R/W	0x0	DMA5_HLAF_IRQ_EN DMA 5 Half package Transfer Interrupt Enable. 0: Disable, 1: Enable.
19	/	/	/
18	R/W	0x0	DMA4_QUEUE_IRQ_EN DMA 4 Queue End Transfer Interrupt Enable. 0: Disable, 1: Enable.
17	R/W	0x0	DMA4_PKG_IRQ_EN DMA 4 Package End Transfer Interrupt Enable. 0: Disable, 1: Enable.
16	R/W	0x0	DMA4_HLAF_IRQ_EN DMA 4 Half Package Transfer Interrupt Enable. 0: Disable, 1: Enable.
15	/	/	/
14	R/W	0x0	DMA3_QUEUE_IRQ_EN DMA 3 Queue End Transfer Interrupt Enable. 0: Disable, 1: Enable.
13	R/W	0x0	DMA3_PKG_IRQ_EN DMA 3 Package End Transfer Interrupt Enable. 0: Disable, 1: Enable.
12	R/W	0x0	DMA3_HLAF_IRQ_EN DMA 3 Half Package Transfer Interrupt Enable. 0: Disable, 1: Enable.
11	/	/	/
10	R/W	0x0	DMA2_QUEUE_IRQ_EN DMA 2 Queue End Transfer Interrupt Enable. 0: Disable, 1: Enable.
9	R/W	0x0	DMA2_PKG_IRQ_EN DMA 2 Package End Transfer Interrupt Enable. 0: Disable, 1: Enable.
8	R/W	0x0	DMA2_HLAF_IRQ_EN DMA 2 Half Package Transfer Interrupt Enable. 0: Disable, 1: Enable.
7	/	/	/
6	R/W	0x0	DMA1_QUEUE_IRQ_EN DMA 1 Queue End Transfer Interrupt Enable. 0: Disable, 1: Enable.
5	R/W	0x0	DMA1_PKG_IRQ_EN DMA 1 Package End Transfer Interrupt Enable. 0: Disable, 1: Enable.
4	R/W	0x0	DMA1_HLAF_IRQ_EN DMA 1 Half Package Transfer Interrupt Enable. 0: Disable, 1: Enable.

3	/	/	/
2	R/W	0x0	DMA0_QUEUE_IRQ_EN DMA 0 Queue End Transfer Interrupt Enable. 0: Disable, 1: Enable.
1	R/W	0x0	DMA0_PKG_IRQ_EN DMA 0 Package End Transfer Interrupt Enable. 0: Disable, 1: Enable.
0	R/W	0x0	DMA0_HLAF_IRQ_EN DMA 0 Half Package Transfer Interrupt Enable. 0: Disable, 1: Enable

#### 4.11.4.2. DMA IRQ Enable Register1 (Default Value: 0x00000000)

Offset: 0x0004			Register Name: <b>DMA_IRQ_EN_REG1</b>
Bit	R/W	Default/Hex	Description
31:15	/	/	/
14	R/W	0x0	DMA11_QUEUE_IRQ_EN DMA 11 Queue End Transfer Interrupt Enable. 0: Disable, 1: Enable.
13	R/W	0x0	DMA11_PKG_IRQ_EN DMA 11 Package End Transfer Interrupt Enable. 0: Disable 1: Enable
12	R/W	0x0	DMA11_HLAF_IRQ_EN DMA 11 Half Package Transfer Interrupt Enable. 0: Disable 1: Enable
11	/	/	/
10	R/W	0x0	DMA10_QUEUE_IRQ_EN DMA 10 Queue End Transfer Interrupt Enable. 0: Disable 1: Enable
9	R/W	0x0	DMA10_PKG_IRQ_EN DMA 10 Package End Transfer Interrupt Enable. 0: Disable 1: Enable
8	R/W	0x0	DMA10_HLAF_IRQ_EN DMA 10 Half Package Transfer Interrupt Enable. 0: Disable 1: Enable
7	/	/	/
6	R/W	0x0	DMA9_QUEUE_IRQ_EN DMA 9 Queue End Transfer Interrupt Enable. 0: Disable

			1: Enable
5	R/W	0x0	DMA9_PKG_IRQ_EN DMA 9 Package End Transfer Interrupt Enable. 0: Disable 1: Enable
4	R/W	0x0	DMA9_HLAF_IRQ_EN DMA 9 Half package Transfer Interrupt Enable. 0: Disable 1: Enable
3	/	/	/
2	R/W	0x0	DMA8_QUEUE_IRQ_EN DMA 8 Queue End Transfer Interrupt Enable. 0: Disable 1: Enable
1	R/W	0x0	DMA8_PKG_IRQ_EN DMA 8 Package End Transfer Interrupt Enable. 0: Disable 1: Enable
0	R/W	0x0	DMA8_HLAF_IRQ_EN DMA 8 Half Package Transfer Interrupt Enable. 0: Disable 1: Enable

#### 4.11.4.3. DMA IRQ Pending Status Register0 (Default Value: 0x00000000)

Offset:0x10			Register Name: <b>DMA_IRQ_PEND_REG0</b>
Bit	R/W	Default/Hex	Description
31	/	/	/
30	R/W	0x0	DMA7_QUEUE_IRQ_PEND. DMA 7 Queue End Transfer Interrupt Pending. Set 1 to the bit will clear it. 0: No effect, 1: Pending.
29	R/W	0x0	DMA7_PKG_IRQ_PEND DMA 7 Package End Transfer Interrupt Pending. Set 1 to the bit will clear it. 0: No effect, 1: Pending.
28	R/W	0x0	DMA7_HLAF_IRQ_PEND. DMA 7 Half Package Transfer Interrupt Pending. Set 1 to the bit will clear it. 0: No effect, 1: Pending.
27	/	/	/
26	R/W	0x0	DMA6_QUEUE_IRQ_PEND. DMA 6 Queue End Transfer Interrupt Pending. Set 1 to the bit will clear it. 0: No effect, 1: Pending.
25	R/W	0x0	DMA6_PKG_IRQ_PEND DMA 6 Package End Transfer Interrupt Pending. Set 1 to the bit will clear it. 0: No effect, 1: Pending.

24	R/W	0x0	DMA6_HLAF_IRQ_PEND. DMA 6 Half Package Transfer Interrupt Pending. Set 1 to the bit will clear it. 0: No effect, 1: Pending.
23	/	/	/
22	R/W	0x0	DMA5_QUEUE_IRQ_PEND. DMA 5 Queue End Transfer Interrupt Pending. Set 1 to the bit will clear it. 0: No effect, 1: Pending.
21	R/W	0x0	DMA5_PKG_IRQ_PEND DMA 5 Package End Transfer Interrupt Pending. Set 1 to the bit will clear it. 0: No effect, 1: Pending.
20	R/W	0x0	DMA5_HLAF_IRQ_PEND. DMA 5 Half Package Transfer Interrupt Pending. Set 1 to the bit will clear it. 0: No effect, 1: Pending.
19	/	/	/
18	R/W	0x0	DMA4_QUEUE_IRQ_PEND. DMA 4 Queue End Transfer Interrupt Pending. Set 1 to the bit will clear it. 0: No effect, 1: Pending.
17	R/W	0x0	DMA4_PKG_IRQ_PEND DMA 4 Package End Transfer Interrupt Pending. Set 1 to the bit will clear it. 0: No effect, 1: Pending.
16	R/W	0x0	DMA4_HLAF_IRQ_PEND. DMA 4 Half Package Transfer Interrupt Pending. Set 1 to the bit will clear it. 0: No effect, 1: Pending.
15	/	/	/
14	R/W	0x0	DMA3_QUEUE_IRQ_PEND. DMA 3 Queue End Transfer Interrupt Pending. Set 1 to the bit will clear it. 0: No effect, 1: Pending.
13	R/W	0x0	DMA3_PKG_IRQ_PEND DMA 3 Package End Transfer Interrupt Pending. Set 1 to the bit will clear it. 0: No effect, 1: Pending.
12	R/W	0x0	DMA3_HLAF_IRQ_PEND. DMA 3 Half Package Transfer Interrupt Pending. Set 1 to the bit will clear it. 0: No effect, 1: Pending.
11	/	/	/
10	R/W	0x0	DMA2_QUEUE_IRQ_PEND. DMA 2 Queue End Transfer Interrupt Pending. Set 1 to the bit will clear it. 0: No effect, 1: Pending.
9	R/W	0x0	DMA2_PKG_IRQ_PEND DMA 2 Package End Transfer Interrupt Pending. Set 1 to the bit will clear it. 0: No effect, 1: Pending.
8	R/W	0x0	DMA2_HLAF_IRQ_PEND. DMA 2 Half Package Transfer Interrupt Pending. Set 1 to the bit will clear it. 0: No effect, 1: Pending.
7	/	/	/
6	R/W	0x0	DMA1_QUEUE_IRQ_PEND.

			DMA 1 Queue End Transfer Interrupt Pending. Set 1 to the bit will clear it. 0: No effect, 1: Pending.
5	R/W	0x0	DMA1_PKG_IRQ_PEND DMA 1 Package End Transfer Interrupt Pending. Set 1 to the bit will clear it. 0: No effect, 1: Pending.
4	R/W	0x0	DMA1_HLAF_IRQ_PEND. DMA 1 Half Package Transfer Interrupt Pending. Set 1 to the bit will clear it. 0: No effect, 1: Pending.
3	/	/	/
2	R/W	0x0	DMA0_QUEUE_IRQ_PEND. DMA 0 Queue End Transfer Interrupt Pending. Set 1 to the bit will clear it. 0: No effect, 1: Pending.
1	R/W	0x0	DMA0_PKG_IRQ_PEND DMA 0 Package End Transfer Interrupt Pending. Set 1 to the bit will clear it. 0: No effect, 1: Pending.
0	R/W	0x0	DMA0_HLAF_IRQ_PEND. DMA 0 Half Package Transfer Interrupt Pending. Set 1 to the bit will clear it. 0: No effect, 1: Pending.

#### 4.11.4.4. DMA IRQ Pending Status Register1 (Default Value: 0x00000000)

Offset:0x14			Register Name: <b>DMA_IRQ_PEND_REG1</b>
Bit	R/W	Default/Hex	Description
31:15	/	/	/
14	R/W	0x0	DMA11_QUEUE_IRQ_PEND. DMA 11 Queue End Transfer Interrupt Pending. Set 1 to the bit will clear it. 0: No effect 1: Pending
13	R/W	0x0	DMA11_PKG_IRQ_PEND DMA 11 Package End Transfer Interrupt Pending. Set 1 to the bit will clear it. 0: No effect 1: Pending
12	R/W	0x0	DMA11_HLAF_IRQ_PEND. DMA 11 Half Package Transfer Interrupt Pending. Set 1 to the bit will clear it. 0: No effect 1: Pending
11	/	/	/
10	R/W	0x0	DMA10_QUEUE_IRQ_PEND. DMA 10 Queue End Transfer Interrupt Pending. Set 1 to the bit will clear it. 0: No effect 1: Pending
9	R/W	0x0	DMA10_PKG_IRQ_PEND



			DMA 10 Package End Transfer Interrupt Pending. Set 1 to the bit will clear it. 0: No effect 1: Pending
8	R/W	0x0	DMA10_HLAF_IRQ_PEND. DMA 10 Half Package Transfer Interrupt Pending. Set 1 to the bit will clear it. 0: No effect 1: Pending
7	/	/	/
6	R/W	0x0	DMA9_QUEUE_IRQ_PEND. DMA 9 Queue End Transfer Interrupt Pending. Set 1 to the bit will clear it. 0: No effect 1: Pending
5	R/W	0x0	DMA9_PKG_IRQ_PEND DMA 9 Package End Transfer Interrupt Pending. Set 1 to the bit will clear it. 0: No effect 1: Pending
4	R/W	0x0	DMA9_HLAF_IRQ_PEND. DMA 9 Half Package Transfer Interrupt Pending. Set 1 to the bit will clear it. 0: No effect 1: Pending
3	/	/	/
2	R/W	0x0	DMA8_QUEUE_IRQ_PEND. DMA 8 Queue End Transfer Interrupt Pending. Set 1 to the bit will clear it. 0: No effect 1: Pending
1	R/W	0x0	DMA8_PKG_IRQ_PEND DMA 8 Package End Transfer Interrupt Pending. Set 1 to the bit will clear it. 0: No effect 1: Pending
0	R/W	0x0	DMA8_HLAF_IRQ_PEND. DMA 8 Half Package Transfer Interrupt Pending. Set 1 to the bit will clear it. 0: No effect 1: Pending

#### 4.11.4.5. DMA Security Register (Default Value: 0x00000000)

Offset:0x20			Register Name: <b>DMA_SECURE_REG</b>
Bit	R/W	Default/Hex	Description
31:8	/	/	/
11	R/W	0x0	DMA11_SEC DMA channel 11 security. 0: Secure,

			1: Non-secure.
10	R/W	0x0	DMA10_SEC DMA channel 10 security. 0: Secure, 1: Non-secure.
9	R/W	0x0	DMA9_SEC DMA channel 9 security. 0: Secure, 1: Non-secure.
8	R/W	0x0	DMA8_SEC DMA channel 8 security. 0: Secure, 1: Non-secure.
7	R/W	0x0	DMA7_SEC DMA channel 7 security. 0: Secure, 1: Non-secure.
6	R/W	0x0	DMA6_SEC DMA channel 6 security. 0: Secure, 1: Non-secure.
5	R/W	0x0	DMA5_SEC DMA channel 5 security. 0: Secure, 1: Non-secure.
4	R/W	0x0	DMA4_SECURE. Indicating DMA 4 security. 0: Secure, 1: Non-secure.
3	R/W	0x0	DMA3_SECURE. Indicating DMA 3 security. 0: Secure, 1: Non-secure.
2	R/W	0x0	DMA2_SECURE. Indicating DMA 2 security. 0: Secure, 1: Non-secure.
1	R/W	0x0	DMA1_SECURE. Indicating DMA 1 security. 0: Secure, 1: Non-secure.
0	R/W	0x0	DMA0_SECURE. Indicating DMA 0 security. 0: Secure, 1: Non-secure.

**4.11.4.6. DMA Auto Gating Register (Default Value: 0x00000000)**

Offset:0x28			Register Name: DMA_AUTO_GATE_REG
Bit	R/W	Default/Hex	Description
31:3	/	/	/
2	R/W	0x0	DMA_MCLK_CIRCUIT. DMA MCLK interface circuit auto gating bit. 0: Auto gating enable 1: Auto gating disable.
1	R/W	0x0	DMA_COMMON_CIRCUIT. DMA common circuit auto gating bit. 0: Auto gating enable 1: Auto gating disable.
0	R/W	0x0	DMA_CHAN_CIRCUIT. DMA channel circuit auto gating bit. 0: Auto gating enable 1: Auto gating disable.

**4.11.4.7. DMA Status Register (Default Value: 0x00000000)**

Offset:0x30			Register Name: DMA_STA_REG
Bit	R/W	Default/Hex	Description
31	/	/	/
30	RO	0x0	MBUS FIFO Status 0:Empty 1:Not Empty
29:12	/	/	/
11	RO	0x0	DMA11_STATUS DMA Channel 11 Status. 0: Idle 1: Busy
10	RO	0x0	DMA10_STATUS DMA Channel 10 Status. 0: Idle 1: Busy
9	RO	0x0	DMA9_STATUS DMA Channel 9 Status. 0: Idle 1: Busy
8	RO	0x0	DMA8_STATUS DMA Channel 8 Status. 0: Idle 1: Busy

7	RO	0x0	DMA7_STATUS DMA Channel 7 Status. 0: Idle 1: Busy
6	RO	0x0	DMA6_STATUS DMA Channel 6 Status. 0: Idle 1: Busy
5	RO	0x0	DMA5_STATUS DMA Channel 5 Status. 0: Idle 1: Busy
4	RO	0x0	DMA4_STATUS DMA Channel 4 Status. 0: Idle 1: Busy.
3	RO	0x0	DMA3_STATUS DMA Channel 3 Status. 0: Idle 1: Busy.
2	RO	0x0	DMA2_STATUS DMA Channel 2 Status. 0: Idle, 1: Busy.
1	RO	0x0	DMA1_STATUS DMA Channel 1 Status. 0: Idle, 1: Busy.
0	RO	0x0	DMA0_STATUS DMA Channel 0 Status. 0: Idle, 1: Busy.

#### 4.11.4.8. DMA Channel Enable Register (Default Value: 0x00000000)

Offset: 0x100+N*0x40+0x0(N=0~11)			Register Name: <b>DMA_EN_REG</b>
Bit	R/W	Default/Hex	Description
31:1	/	/	/
0	R/W	0x0	DMA_EN. DMA Channel Enable 0: Disable 1: Enable.

**4.11.4.9. DMA Channel Pause Register (Default Value: 0x00000000)**

Offset: 0x100+N*0x40+0x4(N=0~11)			Register Name: <b>DMA_PAU_REG</b>
Bit	R/W	Default/Hex	Description
31:1	/	/	/
0	R/W	0x0	DMA_PAUSE. Pausing DMA Channel Transfer Data. 0: Resume Transferring, 1: Pause Transferring.

**4.11.4.10. DMA Channel Descriptor Address Register (Default Value: 0x00000000)**

Offset: 0x100+N*0x40+0x8(N=0~11)			Register Name: <b>DMA_DESC_ADDR_REG</b>
Bit	R/W	Default/Hex	Description
31:0	R/W	0x0	DMA_DESC_ADDR DMA Channel Descriptor Address. The Descriptor Address must be word-aligned.

**4.11.4.11. DMA Channel Configuration Register (Default Value: 0x00000000)**

Offset: 0x100+N*0x40+0xC(N=0~11)			Register Name: <b>DMA_CFG_REG</b>
Bit	R/W	Default/Hex	Description
31:27	/	/	/
26:25	RO	0x0	DMA_DEST_DATA_WIDTH. DMA Destination Data Width. 00: 8-bit 01: 16-bit 10: 32-bit 11: 64-bit
24	/	/	/
23:22	RO	0x0	DMA_DEST_BST_LEN. DMA Destination Burst Length. 00: 1 01: 4 10: 8 11: 16
21	RO	0x0	DMA_ADDR_MODE. DMA Destination Address Mode 0x0: Linear Mode 0x1: IO Mode
20:16	RO		DMA_DEST_DRQ_TYPE. DMA Destination DRQ Type The details in <i>DRQ Type and Port Corresponding Relation</i> .

15:11	/	/	/
10:9	RO	0x0	DMA_SRC_DATA_WIDTH. DMA Source Data Width. 00: 8-bit 01: 16-bit 10: 32-bit 11: 64-bit
8	/	/	/
7:6	RO	0x0	DMA_SRC_BST_LEN. DMA Source Burst Length. 00: 1 01: 4 10: 8 11: 16
5	RO	0x0	DMA_SRC_ADDR_MODE. DMA Source Address Mode 0: Linear Mode 1: IO Mode
4:0	RO	0x0	DMA_SRC_DRQ_TYPE. DMA Source DRQ Type The details in <i>DRQ Type and Port Corresponding Relation</i> .

**4.11.4.12. DMA Channel Current Source Address Register (Default Value: 0x00000000)**

Offset: 0x100+N*0x40+0x10(N=0~11)			Register Name: <b>DMA_CUR_SRC_REG</b>
Bit	R/W	Default/Hex	Description
31:0	RO	0x0	DMA_CUR_SRC. DMA Channel Current Source Address, read only.

**4.11.4.13. DMA Channel Current Destination Address Register (Default Value: 0x00000000)**

Offset: 0x100+N*0x40+0x14(N=0~11)			Register Name: <b>DMA_CUR_DEST_REG</b>
Bit	R/W	Default/Hex	Description
31:0	RO	0	DMA_CUR_DEST. DMA Channel Current Destination Address, read only.

**4.11.4.14. DMA Channel Byte Counter Left Register (Default Value: 0x00000000)**

Offset: 0x100+N*0x40+0x18(N=0~11)			Register Name: <b>DMA_BCNT_LEFT_REG</b>
Bit	R/W	Default/Hex	Description
31:25	/	/	/
24:0	RO	0x0	DMA_BCNT_LEFT.

			DMA Channel Byte Counter Left, read only.
--	--	--	---

**4.11.4.15. DMA Channel Parameter Register (Default Value: 0x00000000)**

Offset: 0x100+N*0x40+0x1C(N=0~11)			Register Name: <b>DMA_PARA_REG</b>
Bit	R/W	Default/Hex	Description
31:8	/	/	/
7:0	RO	0x0	WAIT_CYC. Wait Clock Cycles n.

**4.11.4.16. DMA Former Descriptor Address Register (Default Value: 0x00000000)**

Offset: 0x100+N*0x40+0x2C(N=0~11)			Register Name: <b>DMA_FDESC_ADDR_REG</b>
Bit	R/W	Default/Hex	Description
31:0	RO	0x0	DMA_FDESC_ADDR. This register is used to storing the former value of <i>DMA Channel Descriptor Address Register</i> .

**4.11.4.17. DMA Package Number Register (Default Value: 0x00000000)**

Offset: 0x100+N*0x40+0x30(N=0~11)			Register Name: <b>DMA_PKG_NUM_REG</b>
Bit	R/W	Default/Hex	Description
31:0	RO	0x0	DMA_PKG_NUM. This register will record the number of packages which has been completed in one transmission.

## 4.12. GIC

### 4.12.1. Interrupt Source

Interruptnumber	Interrupt Source	Description
0	SGI 0	SGI 0 interrupt
1	SGI 1	SGI 1 interrupt
2	SGI 2	SGI 2 interrupt
3	SGI 3	SGI 3 interrupt
4	SGI 4	SGI 4 interrupt
5	SGI 5	SGI 5 interrupt
6	SGI 6	SGI 6 interrupt
7	SGI 7	SGI 7 interrupt
8	SGI 8	SGI 8 interrupt
9	SGI 9	SGI 9 interrupt
10	SGI 10	SGI 10 interrupt
11	SGI 11	SGI 11 interrupt
12	SGI 12	SGI 12 interrupt
13	SGI 13	SGI 13 interrupt
14	SGI 14	SGI 14 interrupt
15	SGI 15	SGI 15 interrupt
16	PPI 0	PPI 0 interrupt
17	PPI 1	PPI 1 interrupt
18	PPI 2	PPI 2 interrupt
19	PPI 3	PPI 3 interrupt
20	PPI 4	PPI 4 interrupt
21	PPI 5	PPI 5 interrupt
22	PPI 6	PPI 6 interrupt
23	PPI 7	PPI 7 interrupt
24	PPI 8	PPI 8 interrupt
25	PPI 9	PPI 9 interrupt
26	PPI 10	PPI 10 interrupt
27	PPI 11	PPI 11 interrupt
28	PPI 12	PPI 12 interrupt
29	PPI 13	PPI 13 interrupt
30	PPI 14	PPI 14 interrupt
31	PPI 15	PPI 15 interrupt
32	UART 0	UART 0 interrupt
33	UART 1	UART 1 interrupt
34	UART 2	UART 2 interrupt
35	UART 3	UART 3 interrupt



36	/	/
37	/	/
38	TWI 0	TWI 0 interrupt
39	TWI 1	TWI 1 interrupt
40	TWI 2	TWI 2 interrupt
41	/	/
42	/	/
43	PA_EINT	PA interrupt
44	OWA	OWA interrupt
45	I2S/PCM-0	I2S/PCM-0 interrupt
46	I2S/PCM-1	I2S/PCM-1 interrupt
47	I2S/PCM-2	I2S/PCM-2 interrupt
48	/	/
49	PG_EINT	PG_EINT interrupt
50	Timer 0	Timer 0 interrupt
51	Timer 1	Timer 1 interrupt
52	/	/
53	/	/
54	/	/
55	/	/
56	/	/
57	Watchdog	Watchdog interrupt
58	/	/
59	/	/
60	/	/
61	Audio Codec	Audio Codec interrupt
62	KEYADC	KEYADC interrupt
63	THS	Thermal Sensor interrupt
64	External NMI	External Non-Mask Interrupt
65	R_timer 0	R_timer 0 interrupt
66	R_timer 1	R_timer 1 interrupt
67	/	/
68	R_watchdog	R_watchdog interrupt
69	R_CIR-RX	R_CIR-RX interrupt
70	R_UART	R_UART interrupt
71	/	/
72	R_Alarm 0	R_Alarm 0 interrupt
73	R_Alarm 1	R_Alarm 1 interrupt
74	R_timer 2	R_timer 2 interrupt
75	R_timer 3	R_timer 3 interrupt
76	R_TWI	R_TWI interrupt
77	R_PL_EINT	R_PL_EINT interrupt
78	R_TWD	R_TWD interrupt
79	/	/

80	/	/
81	M-box	M-box interrupt
82	DMA	DMA channel interrupt
83	HS Timer	HS Timer interrupt
84	/	/
85	/	/
86	/	/
87	/	/
88	SMC	SMC interrupt
89	/	/
90	VE	VE interrupt
91	/	/
92	SD/MMC 0	SD/MMC Host Controller 0 interrupt
93	SD/MMC 1	SD/MMC Host Controller 1 interrupt
94	SD/MMC 2	SD/MMC Host Controller 2 interrupt
95	/	/
96	/	/
97	SPI 0	SPI 0 interrupt
98	SPI 1	SPI 1 interrupt
99	/	/
100	/	/
101	/	/
102	NAND	NAND Flash Controller interrupt
103	USB-OTG_Device	USB-OTG_Device interrupt
104	USB-OTG_EHCI0	USB-OTG_EHCI0 interrupt
105	USB-OTG_OHCI0	USB-OTG_OHCI0 interrupt
106	USB-EHCI1	USB-EHCI1 interrupt
107	USB-OHCI1	USB-OHCI1 interrupt
108	USB-EHCI2	USB-EHCI2 interrupt
109	USB-OHCI2	USB-OHCI2 interrupt
110	USB-EHCI3	USB-EHCI3 interrupt
111	USB-OHCI3	USB-OHCI3 interrupt
112	SS_S	SS_S interrupt
113	TS	TS interrupt
114	EMAC	EMAC interrupt
115	SCR	SCR interrupt
116	CSI	CSI interrupt
117	CSI_CCI	CSI_CCI interrupt
118	LCD0	LCD0 Controller interrupt
119	LCD1	LCD1 Controller interrupt
120	HDMI	HDMI interrupt
121	/	/
122	/	/
123	/	/

124	TVE	TVE interrupt
125	DIT	DIT interrupt
126	SS_NS	SS_NS interrupt
127	DE	DE interrupt
128	/	/
129	GPU-GP	GPU-GP interrupt
130	GPU-GPMMU	GPU-GPMMU interrupt
131	GPU-PP0	GPU-PP0 interrupt
132	GPU-PPMMU0	GPU-PPMMU0 interrupt
133	GPU-PMU	GPU-PMU interrupt
134	GPU-PP1	GPU-PP1 interrupt
135	GPU-PPMMU1	GPU-PPMMU1 interrupt
136	/	/
137	/	/
138	/	/
139	/	/
140	CTI0	CTI0 interrupt
141	CTI1	CTI1 interrupt
142	CTI2	CTI2 interrupt
143	CTI3	CTI3 interrupt
144	COMMTX0	COMMTX0 interrupt
145	COMMTX1	COMMTX1 interrupt
146	COMMTX2	COMMTX2 interrupt
147	COMMTX3	COMMTX3 interrupt
148	COMMRX0	COMMRX0 interrupt
149	COMMRX1	COMMRX1 interrupt
150	COMMRX2	COMMRX2 interrupt
151	COMMRX3	COMMRX3 interrupt
152	PMU0	PMU0 interrupt
153	PMU1	PMU1 interrupt
154	PMU2	PMU2 interrupt
155	PMU3	PMU3 interrupt
156	AXI_ERROR	AXI_ERROR interrupt

**Note:**For details about GIC, please refer to the *GIC PL400 technical reference manual* and *ARM GIC Architecture Specification V2.0*.

## 4.13. Message Box

### 4.13.1. Overview

Message Box provides an MSGBox-interrupt mechanism for on-chip processors intercommunication.

The MSGBox-interrupt mechanism allows the software to establish a communication channel between the two users through a set of registers and associated interrupt signals by sending or receiving messages.

The Message Box includes the following features:

- Two users for Message Box instance(User0 for CPUS and User1 for CPU0/CPU1)
- Eight Message Queues for the MSGBox instance
- Each of Queues could be configured as transmitter or receiver for user
- Two interrupts (one per user ) for the MSGBox instance
- Register polling for the MSGBox instance
- 32-bit message width
- Four-message FIFO depth for Each message queue

### 4.13.2. Functionalities Description

Confidential

4.13.2.1. Typical Applications

### Typical Application Flow Chart

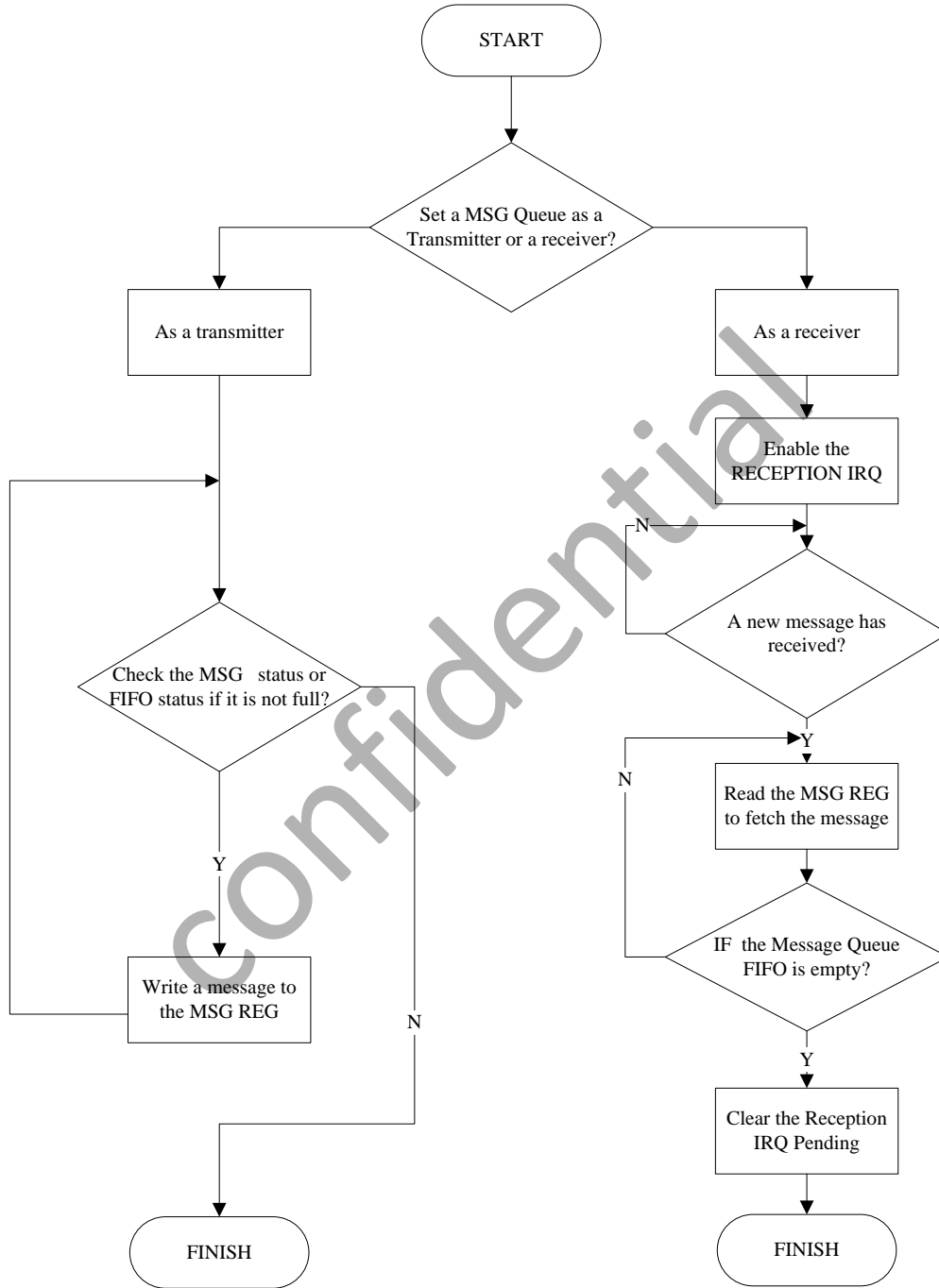

Figure 4-7. Message Box Typical Application Chart

4.13.2.2. Functional Block Diagram

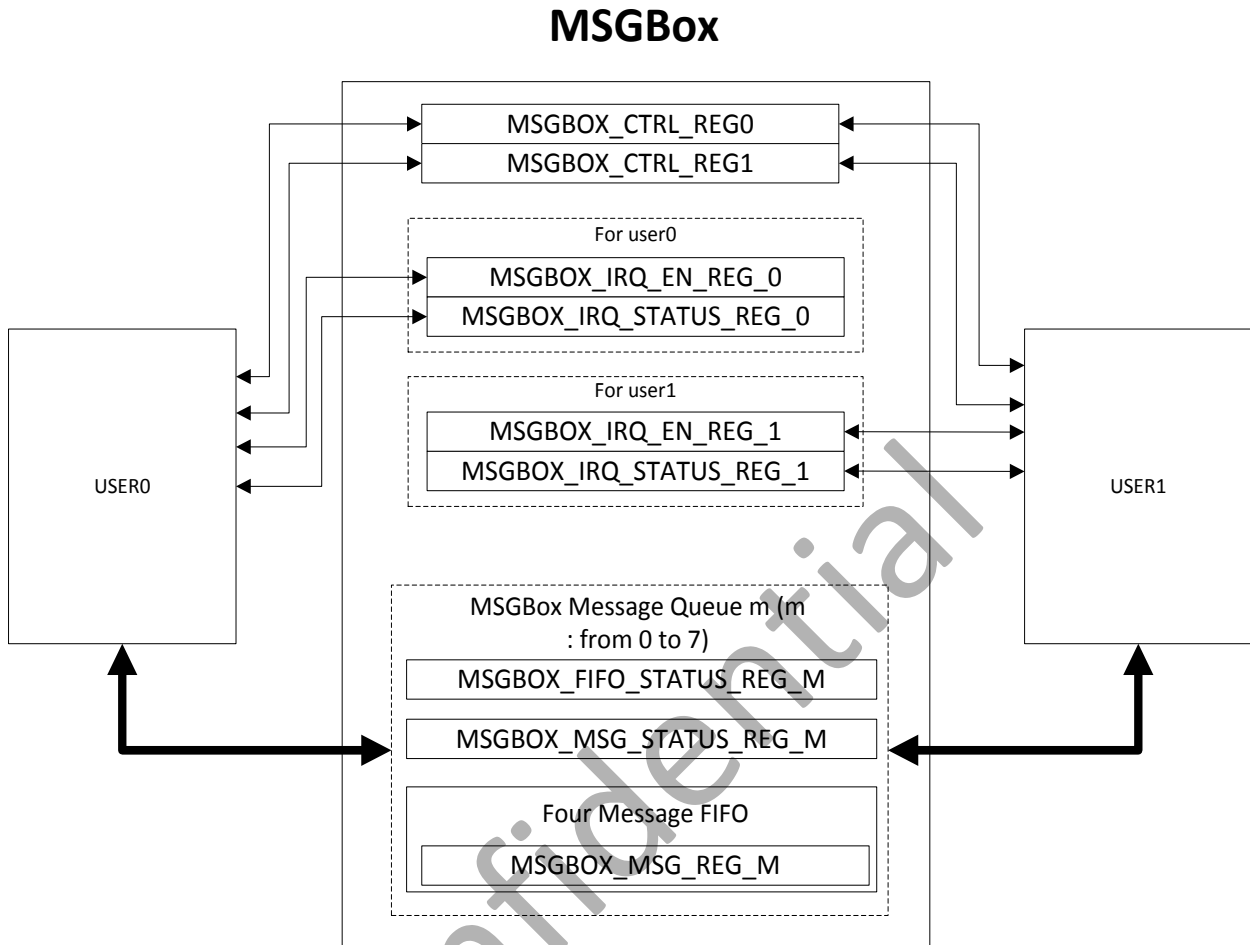

Figure 4-8. Message Box Functional Block Diagram

4.13.3. Operation Principle

4.13.3.1. Message Queue Assignment

To transmit messages from a user to the other user through any Message Queue, set the corresponding bit in the `MSGBOX_CTRL_REG0/MSGBOX_CTRL_REG1` register.

When a 32-bit message is written to the `MSGBOX_MSG_REG_M` register, the message is appended into the FIFO queue. This queue holds 4 messages. If the queue is full, the message is discarded. The receiver user could read the `MSGBOX_MSG_REG_M` (m is the message queue number, where m=0 to 7) register to retrieve a message from the corresponding Message Queue FIFO.

It is recommended that register polling be used for a user to send a message:

- Set a Message Queue as a transmitter (in the **MSGBOX\_CTRL\_REG0/1**).
- Check the FIFO status or the message status (in the **MSGBOX\_FIFO\_STATUS\_REG\_M** or **MSGBOX\_MSG\_STATUS\_REG\_M**).
- Write the message to the corresponding **MSGBOX\_MSG\_REG\_M** register, if space is available.

The transmit interrupt might be used when the initial MSGBox status indicates that the Message Queue is full. In this case, the sender can enable the corresponding **MSGBOX\_IRQ\_EN\_REG\_U** interrupt for the user. This allows the user to be notified by interrupt when the message queue is not full.

#### 4.13.3.2. Interrupt request

An interrupt request allows the user of the MSGBox to be notified when a new message is received or when the message queue is not full.

An event can generate an interrupt request when enable the corresponding bit in the **MSGBOX\_IRQ\_EN\_REG\_U** (u is the user number, where u=0 or 1) register. Events are reported in the appropriate **MSGBOX\_IRQ\_STATUS\_REG\_U** register.

An event stops generating interrupt requests when disable the corresponding bit in the **MSGBOX\_IRQ\_EN\_REG\_U** register.

In case of the **MSGBOX\_IRQ\_STATUS\_REG\_U** register, the event is reported in the corresponding bit even if the interrupt request generation is disabled for this event.

#### 4.13.4. Message Box Register List

Module Name	Base Address
MSGBOX	0x01C17000

Register Name	Offset	Description
MSGBOX_CTRL_REG0	0x0000	Message Queue Attribute Control Register 0
MSGBOX_CTRL_REG1	0x0004	Message Queue Attribute Control Register 1
MSGBOXU_IRQ_EN_REG	0x0040+n*0x20	IRQ Enable For User N(N=0,1)
MSGBOXU_IRQ_STATUS_REG	0x0050+n*0x20	IRQ Status For User N(N=0,1)
MSGBOXM_FIFO_STATUS_REG	0x0100+N*0x4	FIFO Status For Message Queue N(N = 0~7)
MSGBOXM_MSG_STATUS_REG	0x0140+N*0x4	Message Status For Message Queue N(N=0~7)
MSGBOXM_MSG_REG	0x0180+N*0x4	Message Register For Message Queue N(N=0~7)

### 4.13.5. Message Box Register Description

#### 4.13.5.1. MSGBox Control Register 0(Default Value: 0x10101010)

Offset: 0x00			Register Name: MSGBOX_CTRL_REG0
Bit	R/W	Default/Hex	Description
31:29	/	/	/
28	R/W	0x1	TRANSMIT_MQ3. Message Queue 3 is a Transmitter of user u. 0: user0 1: user1
27:25	/	/	/
24	R/W	0x0	RECEPTION_MQ3. Message Queue 3 is a Receiver of user u. 0: user0 1: user1
23:21	/	/	/
20	R/W	0x1	TRANSMIT_MQ2. Message Queue 2 is a Transmitter of user u. 0: user0 1: user1
19:17	/	/	/
16	R/W	0x0	RECEPTION_MQ2. Message Queue 2 is a Receiver of user u. 0: user0 1: user1
15:13	/	/	/
12	R/W	0x1	TRANSMIT_MQ1 Message Queue 1 is a Transmitter of user u. 0: user0 1: user1
11:9	/	/	/
8	R/W	0x0	RECEPTION_MQ1. Message Queue 1 is a Receiver of user u. 0: user0 1: user1
7:5	/	/	/
4	R/W	0x1	TRANSMIT_MQ0. Message Queue 0 is a Transmitter of user u. 0: user0 1: user1
3:1	/	/	/
0	R/W	0x0	RECEPTION_MQ0. Message Queue 0 is a Receiver of user u.



			0: user0 1: user1
--	--	--	----------------------

**4.13.5.2. MSGBox Control Register 1(Default Value: 0x10101010)**

Offset: 0x04			Register Name: <b>MSGBOX_CTRL_REG1</b>
Bit	R/W	Default/Hex	Description
31:29	/	/	/
28	R/W	0x1	TRANSMIT_MQ7. Message Queue 7 is a Transmitter of user u. 0: user0 1: user1
27:25	/	/	/
24	R/W	0x0	RECEPTION_MQ7. Message Queue 7 is a Receiver of user u. 0: user0 1: user1
23:21	/	/	/
20	R/W	0x1	TRANSMIT_MQ6. Message Queue 6 is a Transmitter of user u. 0: user0 1: user1
19:17	/	/	/
16	R/W	0x0	RECEPTION_MQ6. Message Queue 6 is a Receiver of user u. 0: user0 1: user1
15:13	/	/	/
12	R/W	0x1	TRANSMIT_MQ5 Message Queue 5 is a Transmitter of user u. 0: user0 1: user1
11:9	/	/	/
8	R/W	0x0	RECEPTION_MQ5. Message Queue 5 is a Receiver of user u. 0: user0 1: user1
7:5	/	/	/
4	R/W	0x1	TRANSMIT_MQ4. Message Queue 4 is a Transmitter of user u. 0: user0 1: user1
3:1	/	/	/

0	R/W	0x0	RECEPTION_MQ4. Message Queue 4 is a Receiver of user u. 0: user0 1: user1
---	-----	-----	--

#### 4.13.5.3. MSGBox IRQ Enable Register (Default Value: 0x00000000)

Offset:0x40+N*0x20 (N=0,1)			Register Name: <b>MSGBOXU_IRQ_EN_REG</b>
Bit	R/W	Default/Hex	Description
31:16	/	/	/
15	R/W	0x0	TRANSMIT_MQ7_IRQ_EN. 0: Disable 1: Enable (It will notify user u by interrupt when Message Queue 7 is not full.)
14	R/W	0x0	RECEPTION_MQ7_IRQ_EN. 0: Disable 1: Enable (It will notify user u by interrupt when Message Queue 7 has received a new message.)
13	R/W	0x0	TRANSMIT_MQ6_IRQ_EN. 0: Disable 1: Enable (It will Notify user u by interrupt when Message Queue 6 is not full.)
12	R/W	0x0	RECEPTION_MQ6_IRQ_EN. 0: Disable 1: Enable (It will notify user u by interrupt when Message Queue 6 has received a new message.)
11	R/W	0x0	TRANSMIT_MQ5_IRQ_EN. 0: Disable 1: Enable (It will notify user u by interrupt when Message Queue 5 is not full.)
10	R/W	0x0	RECEPTION_MQ5_IRQ_EN. 0: Disable 1: Enable (It will notify user u by interrupt when Message Queue 5 has received a new message.)
9	R/W	0x0	TRANSMIT_MQ4_IRQ_EN. 0: Disable 1: Enable (It will notify user u by interrupt when Message Queue 4 is not full.)
8	R/W	0x0	RECEPTION_MQ4_IRQ_EN. 0: Disable 1: Enable (It will notify user u by interrupt when Message Queue 4 has received a new message.)
7	R/W	0x0	TRANSMIT_MQ3_IRQ_EN. 0: Disable

			1: Enable (It will notify user u by interrupt when Message Queue 3 is not full.)
6	R/W	0x0	RECEPTION_MQ3_IRQ_EN. 0: Disable 1: Enable (It will notify user u by interrupt when Message Queue 3 has received a new message.)
5	R/W	0x0	TRANSMIT_MQ2_IRQ_EN. 0: Disable 1: Enable (It will notify user u by interrupt when Message Queue 2 is not full.)
4	R/W	0x0	RECEPTION_MQ2_IRQ_EN. 0: Disable 1: Enable (It will notify user u by interrupt when Message Queue 2 has received a new message.)
3	R/W	0x0	TRANSMIT_MQ1_IRQ_EN. 0: Disable 1: Enable (It will notify user u by interrupt when Message Queue 1 is not full.)
2	R/W	0x0	RECEPTION_MQ1_IRQ_EN. 0: Disable 1: Enable (It will notify user u by interrupt when Message Queue 1 has received a new message.)
1	R/W	0x0	TRANSMIT_MQ0_IRQ_EN. 0: Disable 1: Enable (It will notify user u by interrupt when Message Queue 0 is not full.)
0	R/W	0x0	RECEPTION_MQ0_IRQ_EN. 0: Disable 1: Enable (It will notify user u by interrupt when Message Queue 0 has received a new message.)

#### 4.13.5.4. MSGBox IRQ Status Register u(Default Value: 0x0000AAAA)

Offset:0x50+N*0x20 (N=0,1)			Register Name: <b>MSGBOXU_IRQ_STATUS_REG</b>
Bit	R/W	Default/Hex	Description
31:16	/	/	/
15	R/W	0x1	TRANSMIT_MQ7_IRQ_PEND. 0: No effect, 1: Pending. This bit will be pending for user u when Message Queue 7 is not full. Set one to this bit will clear it.
14	R/W	0x0	RECEPTION_MQ7_IRQ_PEND. 0: No effect, 1: Pending. This bit will be pending for user u when Message Queue 7 has received a new message. Set one to this bit will clear it.

13	R/W	0x1	TRANSMIT_MQ6_IRQ_PEND. 0: No effect, 1: Pending. This bit will be pending for user u when Message Queue 6 is not full. Set one to this bit will clear it.
12	R/W	0x0	RECEPTION_MQ6_IRQ_PEND. 0: No effect, 1: Pending. This bit will be pending for user u when Message Queue 6 has received a new message. Set one to this bit will clear it.
11	R/W	0x1	TRANSMIT_MQ5_IRQ_PEND. 0: No effect, 1: Pending. This bit will be pending for user u when Message Queue 5 is not full. Set one to this bit will clear it.
10	R/W	0x0	RECEPTION_MQ5_IRQ_PEND. 0: No effect, 1: Pending. This bit will be pending for user u when Message Queue 5 has received a new message. Set one to this bit will clear it.
9	R/W	0x1	TRANSMIT_MQ4_IRQ_PEND. 0: No effect, 1: Pending. This bit will be pending for user u when Message Queue 4 is not full. Set one to this bit will clear it.
8	R/W	0x0	RECEPTION_MQ4_IRQ_PEND. 0: No effect, 1: Pending. This bit will be pending for user u when Message Queue 4 has received a new message. Set one to this bit will clear it.
7	R/W	0x1	TRANSMIT_MQ3_IRQ_PEND. 0: No effect, 1: Pending. This bit will be pending for user u when Message Queue 3 is not full. Set one to this bit will clear it.
6	R/W	0x0	RECEPTION_MQ3_IRQ_PEND. 0: No effect, 1: Pending. This bit will be pending for user u when Message Queue 3 has received a new message. Set one to this bit will clear it.
5	R/W	0x1	TRANSMIT_MQ2_IRQ_PEND. 0: No effect, 1: Pending. This bit will be pending for user u when Message Queue 2 is not full. Set one to this bit will clear it.
4	R/W	0x0	RECEPTION_MQ2_IRQ_PEND. 0: No effect, 1: Pending. This bit will be pending for user u when Message Queue 2 has received a new message. Set one to this bit will clear it.
3	R/W	0x1	TRANSMIT_MQ1_IRQ_PEND. 0: No effect, 1: Pending. This bit will be pending for user u when Message Queue 1 is not full. Set one to this bit will clear it.
2	R/W	0x0	RECEPTION_MQ1_IRQ_PEND.

			0: No effect, 1: Pending. This bit will be pending for user u when Message Queue 1 has received a new message. Set one to this bit will clear it.
1	R/W	01	TRANSMIT_MQ0_IRQ_PEND. 0: No effect, 1: Pending. This bit will be pending for user u when Message Queue 0 is not full. Set one to this bit will clear it.
0	R/W	0x0	RECEPTION_MQ0_IRQ_PEND. 0: No effect, 1: Pending. This bit will be pending for user u when Message Queue 0 has received a new message. Set one to this bit will clear it.

**4.13.5.5. MSGBox FIFO Status Register m(Default Value: 0x00000000)**

Offset:0x100+N*0x4 (N=0~7)			Register Name: <b>MSGBOXM_FIFO_STATUS_REG</b>
Bit	R/W	Default/Hex	Description
31: 1	/	/	/
0	RO	0x0	FIFO_FULL_FLAG. 0: The Message FIFO queue is not full (space is available), 1: The Message FIFO queue is full. This FIFO status register has the status related to the message queue.

**4.13.5.6. MSGBox Message Status Register m(Default Value: 0x00000000)**

Offset:0x140+N*0x4 (N=0~7)			Register Name: <b>MSGBOXM_MSG_STATUS_REG</b>
Bit	R/W	Default/Hex	Description
31:3	/	/	/
2:0	RO	0x0	MSG_NUM. Number of unread messages in the message queue. Here, limited to four messages per message queue. 000: There is no message in the message FIFO queue. 001: There is 1 message in the message FIFO queue. 010: There are 2 messages in the message FIFO queue. 011: There are 3 messages in the message FIFO queue. 100: There are 4 messages in the message FIFO queue. 101~111:/

**4.13.5.7. MSGBox Message Queue Register (Default Value: 0x00000000)**

Offset:0x180+N*0x4 (N=0~7)			Register Name: <b>MSGBOXM_MSG_REG</b>
Bit	R/W	Default/Hex	Description

31:0	R/W	0x0	The message register stores the next to be read message of the message FIFO queue. Reads remove the message from the FIFO queue.
------	-----	-----	--

Confidential

## 4.14. Spinlock

### 4.14.1. Overview

Spinlock provides hardware assistance for synchronizing the processes running on multiple processors in the device. The SpinLock module implements thirty-two 32-bit spinlocks (or hardware semaphores), which provide an efficient way to perform a lock operation of a device resource using a single read access, thus avoiding the need for a 'read-modify-write' bus transfer that not all the programmable cores are capable of.

Spinlocks are present to solve the need for synchronization and mutual exclusion between heterogeneous processors and those not operating under a single, shared operating system. There is no alternative mechanism to accomplish these operations between processors in separate subsystems. However, Spinlocks do not solve all system synchronization issues. They have limited applicability and should be used with care to implement higher level synchronization protocols.

A spinlock is appropriate for mutual exclusion for access to a shared data structure. It should be used only when:

- 1) The time to hold the lock is predictable and small (for example, a maximum hold time of less than 200 CPU cycles may be acceptable).
- 2) The locking task cannot be preempted, suspended, or interrupted while holding the lock (this would make the hold time large and unpredictable).
- 3) The lock is lightly contended, that is the chance of any other process (or processor) trying to acquire the lock while it is held is small.

If the conditions are not met, then a spinlock is not a good candidate. One alternative is to use a spinlock for critical section control (engineered to meet the conditions) to implement a higher level semaphore that can support preemption, notification, timeout or other higher level properties.

The Spinlock includes the following features:

- Spinlock module includes 32 spinlocks
- Two kinds of status of lock register: TAKEN and NOT TAKEN

### 4.14.2. Functionalities Description

#### 4.14.2.1. Typical Applications

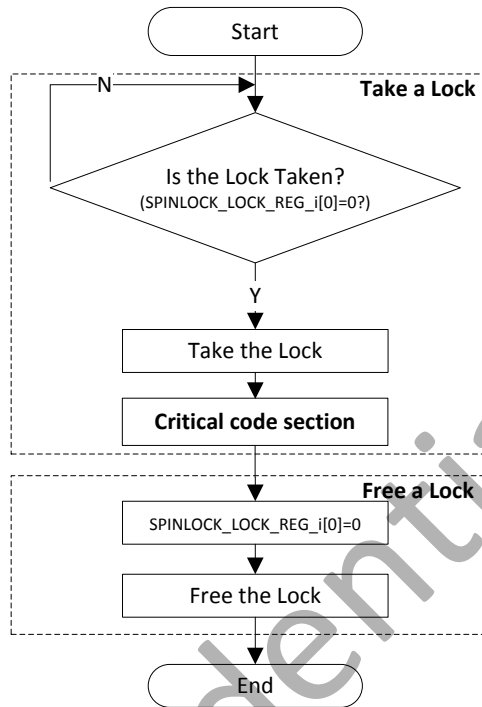

Figure3-11. Spinlock Typical Application Flow Chart

#### 4.14.2.2. Functional Block Diagram

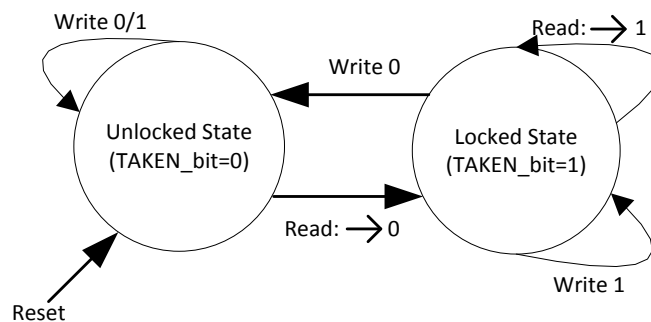

Figure 4-9. Spinlock Lock Register State Diagram

Every lock register has two kinds of states: TAKEN(locked) or NOT TAKEN(Unlocked). Only read-0-access and write-0-access could change lock register' state and the other accesses has no effect. Just 32-bit reads and writes are supported to access all lock registers.



### 4.14.3. Operation Principle

#### 4.14.3.1. Spinlock clock gating and software reset

Spinlock clock gating should be open before using it. Setting **Bus Clock Gating Register1** bit[22] to 1 could activate Spinlock and then de-asserting it's software reset. Setting **AHB1 Module Software Reset Register** bit[22] to 1 could de-assert the software reset of Spinlock. If it is no need to use spinlock, both the gating bit and software reset bit should be set 0.

#### 4.14.3.2. Take and free a spinlock

Checking out **SpinLock Register Status** is necessary when a processor would like to take a spinlock. This register stores all 32 lock registers' status: TAKEN or NOT TAKEN(free).

In order to request to take a spinlock, a processor has to do a read-access to the corresponding lock register. If lock register returns 0, the processor takes this spinlock. And if lock register returns 1, the processor must retry.

Writing 0 to a lock register frees the corresponding spinlock. If the lock register is not taken, write-access has no effect. For a taken spinlock, every processor has the privilege to free this spinlock. But it is suggested that the processor which has taken the spinlock free it for strictness.

### 4.14.4. Spinlock Register List

Module Name	Base Address
SPINLOCK	0x01C18000

Register Name	Offset	Description
SPINLOCK_SYSTATUS_REG	0x0000	Spinlock System Status Register
SPINLOCK_STATUS_REG	0x0010	Spinlock Status Register
SPINLOCK_LOCK_REGN	0x100+N*0x4	Spinlock Register N (N=0~31)

### 4.14.5. Spinlock Register Description

#### 4.14.5.1. Spinlock System Status Register (Default Value: 0x10000000)

Offset: 0x0	Register Name: <b>SPINLOCK_SYSTATUS_REG</b>
-------------	---

Bit	R/W	Default/Hex	Description
31:30	/	/	/
29:28	RO	0x1	LOCKS_NUM. Number of lock registers implemented. 0x1: This instance has 32 lock registers. 0x2: This instance has 64 lock registers. 0x3: This instance has 128 lock registers. 0x4: This instance has 256 lock registers.
27:16	/	/	/
15:9	/	/	/
8	RO	0x0	IU0. In-Use flag0, covering lock register0-31. 0: All lock register 0-31 are in the Not Taken state. 1: At least one of the lock register 0-31 is in the Taken state.
7:0	/	/	/

#### 4.14.5.2. Spinlock Register Status (Default Value: 0x00000000)

Offset: 0x10			Register Name: SPINLOCK_STATUS_REG
Bit	R/W	Default/Hex	Description
[i] (i=0~31)	RO	0x0	LOCK_REG_STATUS. SpinLock[i] status (i=0~31) 0: The Spinlock is free, 1: The Spinlock is taken.

#### 4.14.5.3. Spinlock Register N (N=0 to 31)(Default Value: 0x00000000)

Offset:0x100+N*0x4 (N=0~31)			Register Name: SPINLOCKN_LOCK_REG
Bit	R/W	Default/Hex	Description
31:1	/	/	/
0	R/W	0x0	TAKEN. Lock State. Read 0x0: The lock was previously Not Taken (free).The requester is granted the lock. Write 0x0: Set the lock to Not Taken (free). Read 0x1: The lock was previously Taken. The requester is not granted the lock and must retry. Write 0x1: No update to the lock value.

### 4.14.6. Programming Guidelines

Take CPU0's synchronization with CPUS with Spinlock0 for an example, CPU0 takes the spinlock0 firstly in the instance:  
CPU0

Step 1: CPU0 initializes Spinlock

```
writel(readl(BUS_GATING_REG1)|(1<<22),BUS_GATING_REG1); //open Spinlock clock gating
writel (readl(BUS_RST_REG1)|(1<<22), BUS_RST_REG1); //software reset Spinlock
```

Step 2: CPU0 requests to take spinlock0

```
rdata=readl(SPINLOCK_STATUS_REG0); //check lock register0 status, if it is taken, check till
if(rdata != 0) rdata=readl(SPINLOCK_STATUS_REG0); // lock register0 is free
```

```
⋮
rdata=readl(SPINLOCKN_LOCK_REG0); //request to take spinlock0, if fail, retry till
if(rdata != 0) rdata=readl(SPINLOCKN_LOCK_REG0); // lock register0 is taken
⋮
```

----- CPU0 critical code section -----

Step 3: CPU0 free spinlock0

```
writel (0, SPINLOCKN_LOCK_REG0); //CPU0 frees spinlock0
```

Step 4: CPU0 waits for CPUS' freeing spinlock0

```
writel (readl(SPINLOCK_STATUS_REG0) == 1); // CPU0 waits for CPUS' freeing spinlock0
```

CPUS

Step 1: CPU0 has taken spinlock0, CPUS waits for CPU0' freeing spinlock0

```
while(readl(SPINLOCK_STATUS_REG0) == 1); // CPUS waits for CPU0' freeing spinlock0
```

Step 2: CPUS takes spinlock0 and go on

----- CPUS critical code section -----

Step 3: CPUS frees spinlock0

```
writel (0, SPINLOCKN_LOCK_REG0); //CPUS frees spinlock0
```

## 4.15. Crypto Engine

### 4.15.1. Overview

The Crypto Engine is one encrypt/ decrypt function accelerator. It is suitable for a variety of applications. It can support both encryption/decryption and signature/verification, calculate the hash value. Several modes are supported by the Crypto Engine. The Crypto Engine has a special internal DMA(IDMA) controller to transfer data .

It includes the following features:

- Support symmetrical algorithm :AES, DES, TDES
- Support asymmetrical algorithm :RSA512/1024/2048/3072/4096-bits, ECC 160/224/256/521-bits
- Support secure Hash algorithm: MD5, SHA-1,SHA-224,SHA-256,SHA-384,SHA-512,HMAC-SHA1
- Support 160-bits hardware PRNG with 175-bits seed
- Support 256-bits hardware TRNG
- Support ECB, CBC, CTR modes for DES/TDES
- Support ECB, CBC, CTR, CTS,OFB,CFB,CBC-MAC modes for AES
- Support 128-bits, 192-bits and 256-bits key size for AES
- Support signature and verification
- Support IDMA mode
- Support serial and parallel mode

### 4.15.2. Functionalities Description

4.15.2.1. Block Diagram

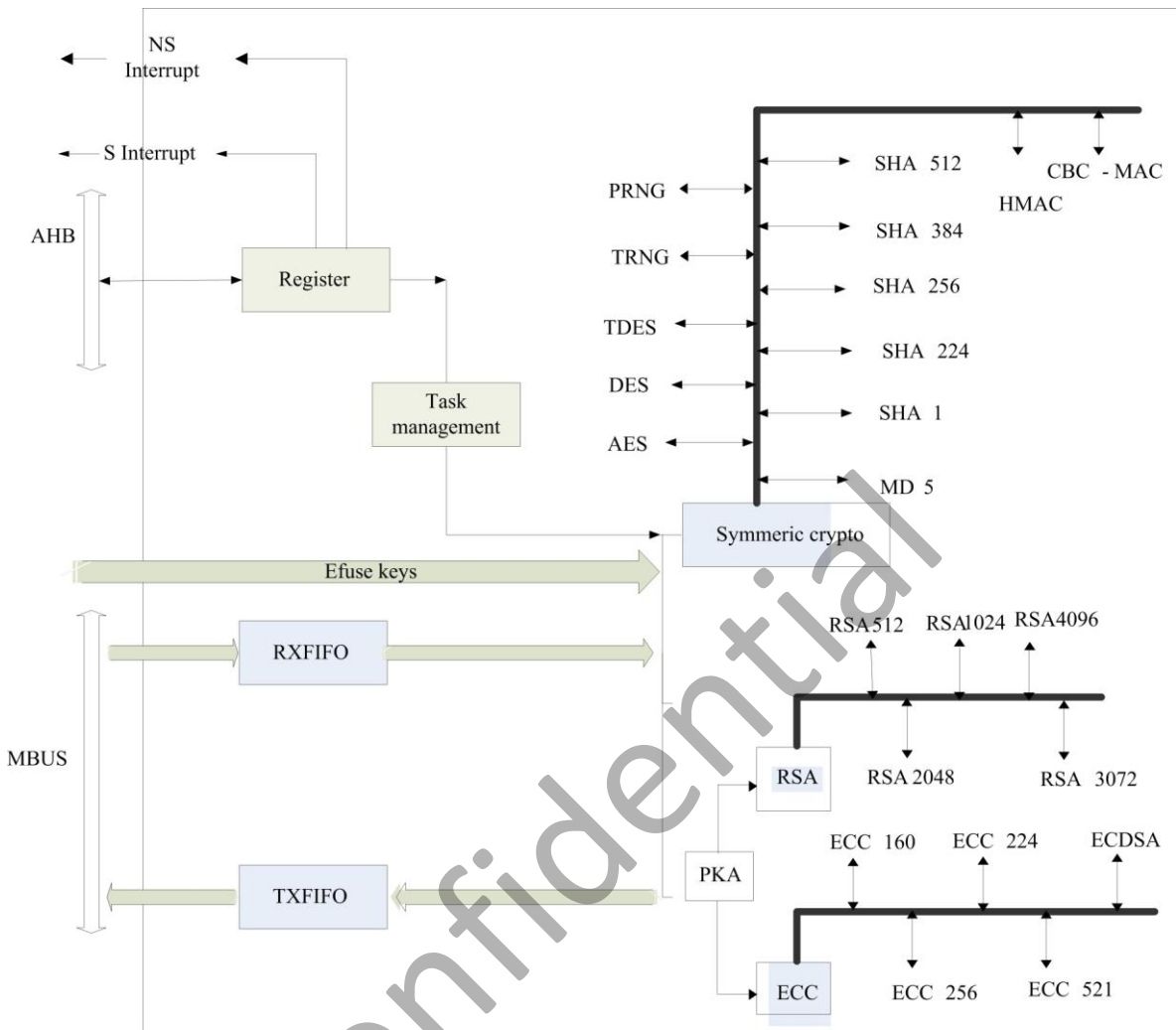

Figure 4-10. Crypto Engine Block Diagram

4.15.2.2. Crypto Engine Task Descriptor

Crypto Engine task descriptor is 44\*4Byte memory.

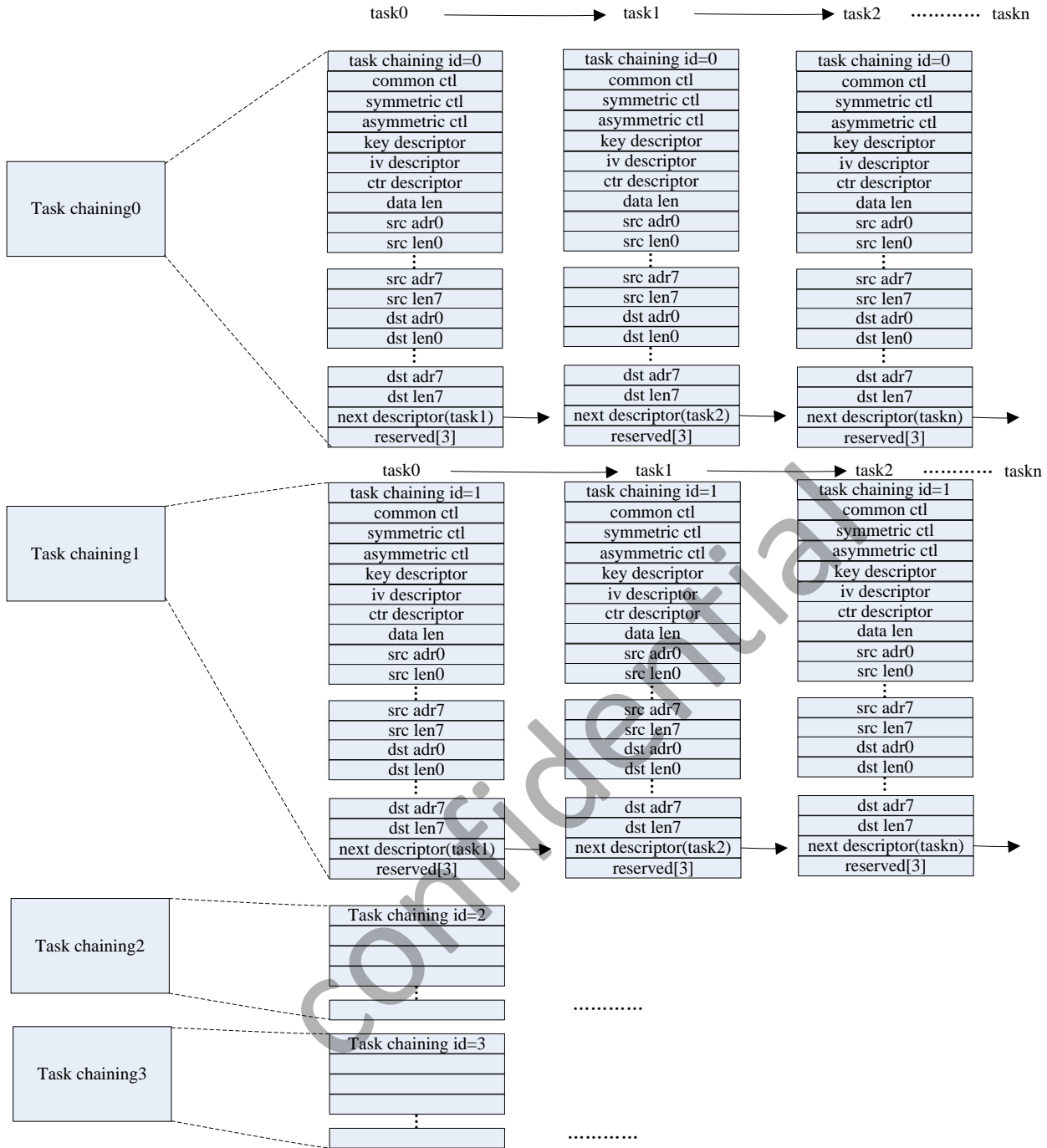

Figure 4-11. Crypto Engine Task Chaining Block Diagram

**task\_descriptor\_queue common control bitmap(32bit)**

Bit	Description
31	Each of the tasks to be an interrupt 0:don't interrupt 1:interrupt
29:28	/
27	DMA Read/Write Consistent

	0:Send end flag after data write-instruction finished 1:Read data when SS received response of write-instruction ,if write-instruction is non-finished, waiting until write-instruction finished.
24	/
23:17	MAC Length for CBC-MAC length=bit[23:17]+1
16	IV_Mode IV Steady of hash algorithm 0: Constants 1: Arbitrary IV Notes: It is only used for SHA-1/SHA-224/SHA-256/SHA-384/SHA-512/ MD5 engine.
15	HMAC_SHA1_Last_Block_Flag When set to "1", it means this is the last block for HMAC-SHA1.
14:9	/
8	SS_OP_DIR SS Operation Direction 0: Encryption 1: Decryption
7	/
6:0	SS_Method 0: AES 1: DES 2: Triple DES (3DES) 3~15: reserved 16: MD5 17: SHA-1 18: SHA-224 19: SHA-256 20: SHA384 21: SHA512 22: HMAC-SHA1 23~31: reserved 32: RSA/DH 33~47: reserved 48: TRNG 49: PRNG 50~63: reserved 64: ECC

**task\_descriptor\_queue symmetric control(32bit)**

Bit	Description
-----	-------------

31:24	/
23:20	SKEY_Select key select for AES 0: Select input SS_KEYx (Normal Mode) 1: Select {SSK} 2: Select {HUK} 3: Select {RSSK} 4-7: Reserved 8-15: Select internal Key n (n from 0 to 7)
19:18	CFB_Mode_Width 0:1-bits 1:8-bits 2:64-bits 3:128-bits
17	/
16	AES_CTS_Last_Block_Flag When set to "1", it means this is the last block for AES-CTS mode. (the size of the last block >128bit)
15:12	/
11:8	SS_OP_Mode SS Operation Mode 0: Electronic Code Book (ECB) mode 1: Cipher Block Chaining (CBC) mode 2: Counter (CTR) mode 3: Ciphertext Stealing (CTS) mode 4: Output feedback (OFB)mode 5: Cipher feedback (CFB)mode 6: CBC-MAC mode Other: reserved
7:4	/
3:2	CTR_Width Counter Width for CTR Mode 0: 16-bits Counter 1: 32-bits Counter 2: 64-bits Counter 3: 128-bits Counter
1:0	AES_Key_Size 0: 128-bits 1: 192-bits 2: 256-bits 3: Reserved

**task\_descriptor\_queue asymmetric control(32bit)**

Bit	Description
-----	-------------



31	/
30:28	RSA_Public_Modular_Width 0:512 bit 1:1024 bit 2:2048 bit 3:3072 bit 4:4096 bit Other: reserved
27:19	/
18:16	RSA_Big_integer_Operation 0:modular exponentiation 1:/ 2:modular multiplication Other: reserved
15	/
14:12	Elliptic_Curve_Parameter_Width 0:160bit 1:/ 2:224bit 3:256bit 4:/ 5:521bit Other: reserved
11:7	/
6:4	ECC_GF(p)_Operation 0:point multiplication 1:point addition 2:point double 3:point verification 4:encrypt 5:decrypt 6:signing
3:0	/

### 4.15.3. Crypto Engine Register List

Module Name	Base Address
CE_N	0x01C15000
CE_S	0x01C15800

Register Name	Offset	Description
CE_TDQ	0x00	Task Descriptor Address
CE_CTR	0x04	Gating Control Register

CE_ICR	0x08	Interrupt Control Register
CE_ISR	0x0c	Interrupt Status Register
CE_TLR	0x10	Task Load Register
CE_TSR	0x14	Task Status Register
CE_ESR	0x18	Task Error type Register
CE_CSSGR	0x1c	Current Source Scatter Group Register
CE_CDSGR	0x20	Current Destination Scatter Group Register
CE_CSAR	0x24	Current Source Address Register
CE_CDAR	0x28	Current Destination Address Register
CE_TPR	0x2c	Throughput Register

#### 4.15.4. Crypto Engine Register Description

##### 4.15.4.1. Crypto Engine Task Descriptor Queue Register(Default Value: 0x00000000)

Offset: 0x00			Register Name: <b>CE_TDQ</b>
Bit	R/W	Default/Hex	Description
31:0	R/W	0	Task_Descriptor_Queue_Address

##### 4.15.4.2. Crypto Engine Control Register(Default Value: 0x00000000)

Offset: 0x04			Register Name: <b>CE_CTR</b>
Bit	R/W	Default/Hex	Description
31:19	/	/	/
18:16	R	x	DIE_ID Die Bonding ID for CE_NS
15:4	/	/	/
3	R/W	0	RSA_CLK_Gating_Enable 0: RSA clk gating enable 1: RSA clk gating disable
2:0	R	x	DIE_ID Die Bonding ID for CE_S

##### 4.15.4.3. Crypto Engine Interrupt Control Register(Default Value: 0x00000000)

Offset: 0x08			Register Name: <b>CE_ICR</b>
Bit	R/W	Default/Hex	Description
31:4	/	/	/
3:0	R/W	0	Task chaining0-3_interrupt_enable

			0: interrupt disable 1: interrupt enable
--	--	--	---

**4.15.4.4. Crypto Engine Interrupt Status Register(Default Value: 0x00000000)**

Offset: 0x0C			Register Name: <b>CE_ISR</b>
Bit	R/W	Default/Hex	Description
31:16	/	/	/
15:4	/	/	/
3:0	R/W	0	Task chaining0-3_End_Pending 0: busy 1: task end It indicates that the processing of encrypt /signing or decrypt/verification has been completed . Notes: Write '1' to clear it.

**4.15.4.5. Crypto Engine Task Load Register(Default Value: 0x00000000)**

Offset: 0x10			Register Name: <b>CE_TLR</b>
Bit	R/W	Default/Hex	Description
31:1	/	/	/
0	R/W	0	Task_Load When set , SS starts to load the configure of task from task descriptor queue and start to perform the task.

**4.15.4.6. Crypto Engine Task Status Register(Default Value: 0x00000000)**

Offset: 0x14			Register Name: <b>CE_TSR</b>
Bit	R/W	Default/Hex	Description
31:3	/	/	/
2:1	R	0	Current task in run 0: task chaining0 1: task chaining1 2: task chaining2 3: task chaining3
0	R	0	SS_Busy 0: idle 1: busy when the bit is"1", indicate that hardware is in busy

**4.15.4.7. Crypto Engine Error Status Register(Default Value: 0x00000000)**

Offset: 0x18			Register Name: <b>CE_ESR</b>
Bit	R/W	Default/Hex	Description
31:16	/	/	/
3+4*n (n=0~3)	/	/	reserved
2+4*n (n=0~3)	R	0	AES_Access_Keysram_Status 0: AES could perform request if destination address is keysram. 1: AES couldn't perform request if destination address is not keysram. Notes: Write '1' to clear it.
1+4*n (n=0~3)	R	0	Task chaining n data length error When the bit is 1, indicate that the configure of data length is error
0+4*n (n=0~3)	R	0	Task chaining n algorithm error When the bit is 1, indicate that SS is not support the algorithm

**4.15.4.8. Crypto Engine Current Source Scatter Group Register(Default Value: 0x00000000)**

Offset: 0x1C			Register Name: <b>CE_CSSGR</b>
Bit	R/W	Default/Hex	Description
31:0	R	0	The current offset in src adr These bits indicate that the offset of source address
15:0	R	0	The current source scatter number When a task is divided to some scatter(max is 8 scatter), these bits indicate that which scatter is executing for source data

**4.15.4.9. Crypto Engine Current Destination Scatter Group Register(Default Value: 0x00000000)**

Offset: 0x20			Register Name: <b>CE_CDSGR</b>
Bit	R/W	Default/Hex	Description
31:16	R	0	The current offset in dst adr These bits indicate that the offset of destination address
15:0	R	0	The current destination scatter number When a task is divided to some scatter(max is 8 scatter), these bits indicate that which scatter is executing for destination data

**4.15.4.10. Crypto Engine Current Source Address Register(Default Value: 0x00000000)**

Offset: 0x24			Register Name: <b>CE_CSAR</b>
Bit	R/W	Default/Hex	Description

31:0	R	0	Current source address of the executing task
------	---	---	--

**4.15.4.11. Crypto Engine Current Destination Address Register(Default Value: 0x00000000)**

Offset: 0x28			Register Name: <b>CE_CDAR</b>
Bit	R/W	Default/Hex	Description
31:0	R	0	Current destination address of the executing task

**4.15.4.12. Crypto Engine Throughput Register(Default Value: 0x00000000)**

Offset: 0x2C			Register Name: <b>CE_TPR</b>
Bit	R/W	Default/Hex	Description
31:0	R/W	0	It indicates the throughput of data from the whole processing. Notes: Write '0' to clear it by CPU.

**4.15.5. Crypto Engine Clock Requirement**

Clock Name	Description	Requirement
ahb_clk	AHB bus clock	>=24MHz
CE_clk	Crypto Engine serial clock	<= 300MHz && >=24MHz

## 4.16. Security ID

### 4.16.1. Overview

There is one 2Kbit on chip EFUSE, which provides 128-bit, 64-bit and one 32-bit electrical fuses for security application. The users can use them as root key, security JTAG key and other applications.

It includes the following features:

- 128-bit electrical fuses for chip ID
- 64-bit electrical fuses for thermal sensor

Confidential

## 4.17. Secure Memory Controller

### 4.17.1. Overview

The SMC is an Advanced Microcontroller Bus Architecture compliant System-on-Chip peripheral. It is a high-performance, area-optimized address space controller with on-chip AMBA bus interfaces that conform to the AMBA Advanced extensible Interface protocol and the AMBA Advanced Peripheral Bus protocol.

You can configure the SMC to provide the optimum security address region control functions required for your intended application.

The SMC includes the following features:

- Enables you to program security access permissions each address region.
- Permits the transfer of data between master and slave only if the security status of the AXI transaction matches the security settings of the memory region it addresses.

### 4.17.2. Functionalities Description

By default, the SMC performs read or write speculative that means it forwards an AXI transaction address to a slave, before it verifies that the AXI transaction is permitted to read address or write address respectively.

The SMC only permits the transfer of data between its AXI bus interfaces, after verifying the access that the read or write access is permitted respectively. If the verification fails, then it prevents the transfer of data between the master and slave as Denied AXI transactions.

When the speculative accesses are disabled, the SMC verifies the permissions of the access before it forwards the access to the slave. If the SMC:

- Permits the access, it commences an AXI transaction to the slave, and it adds one clock latency.
- Denies the access, it prevents the transfer of data between the master and slave. In this situation, the slave is unaware when the SMC prevents the master from accessing the slave.

4.17.2.1. DRM Block Diagram

G.NS.M stands for General Non-secure Master  
 D.NS.M stands for Non-secure Master appointed by DRM  
 S.M. stands for Secure Mater

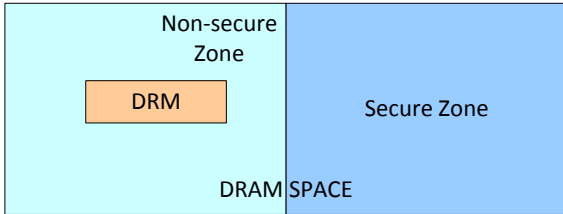

G.NS.M only can read data from NSZ and write data into NSZ  
 D.NS.M can read data from NSZ and DRM, but only can write data into DRM  
 S.M can read data from the whole DRAM SPACE

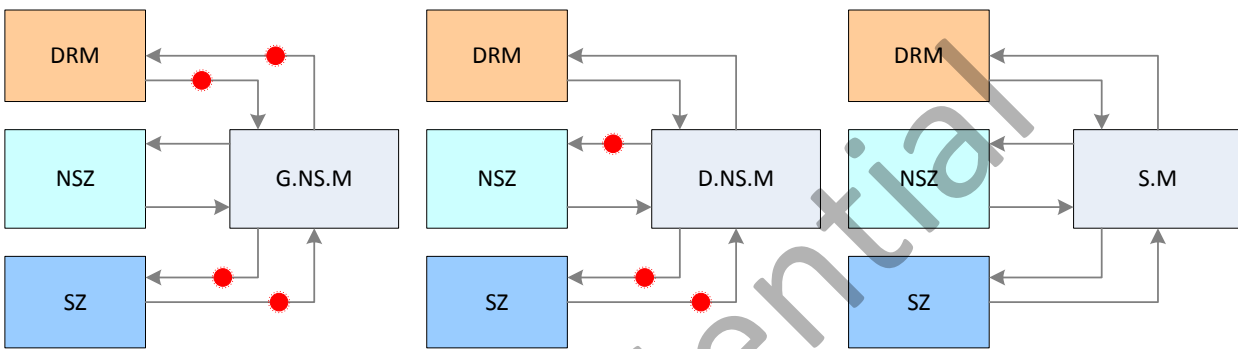

Figure 4-12. DRM Block Diagram

4.17.2.2. Master ID Table

Table 4-2. Master and Master ID

ID	Master	ID	Master
0	CPU	12	VE
1	GPU	13	CSI
2	CPUS	14	NAND
3	ATH (test interface for AHB)	15	Crypto Engine
4	USB0	16	DE_RT-MIXER0
5	MSTG0 (SD/eMMC0)	17	DE_RT-MIXER1
6	MSTG1 (SD/eMMC1)	18	DE_RT-WB
7	MSTG2 (SD/eMMC2)	19	
8	USB1	20	USB3
9	USB2	21	TS
10	EMAC	22	DE Interlace
11		23	



4.17.2.3. Region Size Table

Table 4-3. Region Size

Size<n>	Size of region<n>	Base address constraints
b000000-b001101	Reserved	-
b001110	32KB	-
b001111	64KB	Bit [15] must be zero
b010000	128KB	Bits [16:15] must be zero
b010001	256KB	Bits [17:15] must be zero
b010010	512KB	Bits [18:15] must be zero
b010011	1MB	Bits [19:15] must be zero
b010100	2MB	Bits [20:15] must be zero
b010101	4MB	Bits [21:15] must be zero
b010110	8MB	Bits [22:15] must be zero
b010111	16MB	Bits [23:15] must be zero
b011000	32MB	Bits [24:15] must be zero
b011001	64MB	Bits [25:15] must be zero
b011010	128MB	Bits [26:15] must be zero
b011011	256MB	Bits [27:15] must be zero
b011100	512MB	Bits [28:15] must be zero
b011101	1GB	Bits [29:15] must be zero
b011110	2GB	Bits [30:15] must be zero
b011111	4GB	Bits [31:15] must be zero
B100000	8GB	Bits [32:15] must be zero

4.17.2.4. Security inversion is disabled

Table 4-4. Region security permissions

SPN field	Secure Read	Secure Write	Non-secure Read	Non-secure Write
4b0000	No	No	No	No
4b0100	No	Yes	No	No
4b0001, 4b0101	No	Yes	No	Yes
4b1000	Yes	No	No	No
4b0010, 4b1010	Yes	No	Yes	No
4b1100	Yes	Yes	No	No
4b1001, 4b1101	Yes	Yes	No	Yes
4b0110, 4b1110	Yes	Yes	Yes	No
4b0011-4b1111	Yes	Yes	Yes	Yes

#### 4.17.2.5. Security inversion is enabled

If you enable security inversion, the SMC permits you to program any combination of security permissions as Table 4-5 shows.

Table 4-5. Region security permissions

SPN field	Secure Read	Secure Write	Non-secure Read	Non-secure Write
4b0000	No	No	No	No
4b0001	No	No	No	Yes
4b0010	No	No	Yes	No
4b0011	No	No	Yes	Yes
4b0100	No	Yes	No	No
4b0101	No	Yes	No	Yes
4b0110	No	Yes	Yes	No
4b0111	No	Yes	Yes	Yes
4b1000	Yes	No	No	No
4b1001	Yes	No	No	Yes
4b1010	Yes	No	Yes	No
4b1011	Yes	No	Yes	Yes
4b1100	Yes	Yes	No	No
4b1101	Yes	Yes	No	Yes
4b1110	Yes	Yes	Yes	No
4b1111	Yes	Yes	Yes	Yes

#### 4.17.3. SMC Register List

Module Name	Base Address
SMC	0x01C1E000

Register Name	Offset	Description
SMC_CONFIG_REG	0x0	SMC Configuration Register
SMC_ACTION_REG	0x4	SMC Action Register
SMC_LD_RANGE_REG	0x8	SMC Lock Down Range Register
SMC_LD_SELECT_REG	0xC	SMC Lock Down Select Register
SMC_INT_STATUS_REG	0x10	SMC Interrupt Status Register
SMC_INT_CLEAR_REG	0x14	SMC Interrupt Clear Register
SMC_MST_BYP_REG	0x18	SMC Master Bypass Register
SMC_MST_SEC_REG	0x1C	SMC Master Secure Register
SMC_FAIL_ADDR_REG	0x20	SMC Fail Address Register
SMC_FAIL_CTRL_REG	0x28	SMC Fail Control Register
SMC_FAIL_ID_REG	0x2C	SMC Fail ID Register
SMC_SPECU_CTRL_REG	0x30	SMC Speculation Control Register
SMC_SEC_INV_EN_REG	0x34	SMC Security Inversion Enable Register

SMC_MST_ATTRI_REG	0x48	SMC Master Attribute Register
DRM_MASTER_EN_REG	0x50	DRM Master Enable Register
DRM_ILLACCE_REG	0x58	DRM Illegal Access Register
DRM_STATADDR_REG	0x60	DRM Start Address Register
DRM_ENDADDR_REG	0x68	DRM End Address Register
SMC_REGION_SETUP_LO_REG	0x100+N*0x10	Region Setup Low Register N (N=0,1,2,3,4,5,6,7,8,9,10,11,12,13,14,15)
SMC_REGION_SETUP_HI_REG	0x104+N*0x10	Region Setup High Register N (N=0,1,2,3,4,5,6,7,8,9,10,11,12,13,14,15)
SMC_REGION_ATTR_REG	0x108+N*0x10	Region Attribute Register N (N=0,1,2,3,4,5,6,7,8,9,10,11,12,13,14,15)

#### 4.17.4. SMC Register Description

##### 4.17.4.1. SMC Configuration Register(Default Value: 0x00001F0F)

Offset: 0x0			Register Name: <b>SMC_CONFIG_REG</b>
Bit	R/W	Default/Hex	Description
31:14	/	/	/
13:8	R	0x1F	ADDR_WIDTH_RTN. Address width. Return the width of the AXI address bus. 6'b 000000-6'b011110 reserved. 6'b 011111 = 32-bit ..... 6'b 111111 = 64-bit
7:4	/	/	/
3:0	R	0xF	REGIONS_RTN. Returns the number of the regions that the SMC provides. 4'b0000 = reserved 4'b0001 = 2 regions ..... 4'b1111 = 16 regions.

##### 4.17.4.2. SMC Action Register(Default Value: 0x00000001)

Offset: 0x4			Register Name: <b>SMC_ACTION_REG</b>
Bit	R/W	Default/Hex	Description
31:2	/	/	/
1:0	R/W	0x1	SMC_INT_RESP. Control how the SMC uses the bresps[1:0], rresps[1:0], and smc_int signals when a region permission failure occurs:

			2'b00 = sets smc_int LOW and issues an OKEY response 2'b01 = sets smc_int LOW and issues a DECERR response 2'b10 = sets smc_int HIGH and issues an OKEY response 2'b11 = sets smc_int HIGH and issues a DECERR response
--	--	--	--

**Note:**This action is only valid for CPU access, not for MBUS and DMA access.

#### 4.17.4.3. SMC Lockdown Range Register(Default Value: 0x00000000)

Offset: 0x8			Register Name: <b>SMC_LD_RANGE_REG</b>
Bit	R/W	Default/Hex	Description
31	R/W	0x0	LOCKDOWN_EN. When set to 1, it enables the lockdown_regions field to control the regions that are to be locked.
30:4	/	/	/
3:0	R/W	0x0	NO_REGIONS_LOCKDOWN. Control the number of regions to lockdown when the enable bit is set to 1. 4'b0000 = region no_of_regions-1 is locked 4'b0001 = region no_of_regions-1 to region no_of_regions-2 are locked ..... 4'b1111 = region no_of_regions-1 to region no_of_regions-16 are locked

**Note1:** No\_of\_regions is the value of the no\_of\_regions field in the configuration register.

**Note2:** The value programmed in lockdown\_range register must not be greater than no\_of\_regions-1 ,else all regions are locked.

#### 4.17.4.4. SMC Lockdown Select Register(Default Value: 0x00000000)

Offset: 0xC			Register Name: <b>SMC_LD_SELECT_REG</b>
Bit	R/W	Default/Hex	Description
31:3	/	/	/
2	R/W	0x0	ACCESS_TYPE_SPECU. Modify the access type of the speculation_control register: 0: no effect. The speculation register remains RW. 1: speculation_control register is RO
1	R/W	0x0	ACCESS_TYPE_SEC_INV_EN. Modify the access type of the security_inversion_en register. 0: no effect. Security_inversion_en register remains RW. 1: security_inversion_en register is RO
0	R/W	0x0	ACCESS_TYPE_LOCKDOWN_RANGE. Modify the access type of the lockdown_range register. 0: no effect. Lockdown_range register remains RW 1: lockdown_range register is RO.

**4.17.4.5. SMC Interrupt Status Register(Default Value: 0x00000000)**

Offset: 0x10			Register Name: <b>SMC_INT_STATUS_REG</b>
Bit	R/W	Default/Hex	Description
31:2	/	/	/
1	R	0x0	INT_OVERRUN. When set to 1, it indicates the occurrence of two or more region permission failure since the interrupt was last cleared.
0	R	0x0	INT_STATUS. Return the status of the interrupt. 0: interrupt is inactive. 1: interrupt is active.

**4.17.4.6. SMC Interrupt Clear Register(Default Value: 0x00000000)**

Offset: 0x14			Register Name: <b>SMC_INT_CLEAR_REG</b>
Bit	R/W	Default/Hex	Description
31:0	R/W	0x0	SMC_CLR_REG. Write any value to the int_clear register sets the : Status bit to 0 in the int_status register Overrun bit to 0 in the int_status register. <b>Note:</b> It will be auto cleared after the write operation.

**4.17.4.7. SMC Master Bypass Register(Default Value: 0xFFFFFFFF)**

Offset: 0x18			Register Name: <b>SMC_MST_BYP_REG</b>
Bit	R/W	Default/Hex	Description
31:0	R/W	0xFFFFFFFF	SMC_MASTER_BYPASS_EN. SMC Master n Bypass Enable. (n = 0~31, see the Table 4-2. MASTER and MASTER ID for detail.) Note: Bit[31:0] stand for Master ID [31:0] If the master n bypass enable is set to 0, the master n access must be through the SMC. 0: Bypass Disable 1: Bypass Enable.

**4.17.4.8. SMC Master Secure Register(Default Value: 0x00000000)**

Offset: 0x1C			Register Name: <b>SMC_MST_SEC_REG</b>
Bit	R/W	Default/Hex	Description

31:0	R/W	0x0	SMC_MASTER_SEC. SMC Master n Secure Configuration.(n = 0~31, see the Table 4-2 for detail) 0: secure 1: non-secure.
------	-----	-----	--

#### 4.17.4.9. SMC Fail Address Register(Default Value: 0x00000000)

Offset: 0x20			Register Name: <b>SMC_FAIL_ADDR_REG</b>
Bit	R/W	Default/Hex	Description
31:0	R	0x0	FIRST_ACCESS_FAIL. Return the address bits [31:0] of the first access to fail a region permission check after the interrupt was cleared. For external 16-bit DDR2, the address [2:0] is fixed to zero. For external 32-bit DDR2 and 16-bit DDR3, the address [3:0] is fixed to zero. For external 32-bit DDR3, the address [4:0] is fixed to zero.

**Note:**If the master ID="SRAM" and the register value is between 0x80000 to 0xBFFFF, the real address should be divide by 4.

#### 4.17.4.10. SMC Fail Control Register(Default Value: 0x00000000)

Offset: 0x28			Register Name: <b>SMC_FAIL_CTRL_REG</b>
Bit	R/W	Default/Hex	Description
31:25	/	/	/
24	R	0x0	READ_WRITE. This bit indicates whether the first access to fail a region permission check was a write or read as: 0 = read access 1 = write access.
23:22	/	/	/
21	R	0x0	NON_SECURE. After clearing the interrupt status, this bit indicates whether the first access to fail a region permission check was non-secure. Read as: 0 = secure access 1 = non-secure access
20	R	0x0	PRIVILEGED. After clearing the interrupt status, this bit indicates whether the first access to fail a region permission check was privileged. Read as: 0 = unprivileged access. 1 = privileged access
19:0	/	/	/

**4.17.4.11. SMC Fail ID Register(Default Value: 0x00001F00)**

Offset: 0x2C			Register Name: <b>SMC_FAIL_ID_REG</b>
Bit	R/W	Default/Hex	Description
31:24	/	/	/
23:16	R	0x0	FAIL_BST_LEN. Fail burst length. 0 = 1 word length ..... 0xf =16 words length
15:8	/	/	/
7:0	R	0x0	FAIL_MASTER_ID. Fail Master ID. The value stands for master id, see the Table 4-2 MASTER and MASTER ID for detail.

**4.17.4.12. SMC Speculation Control Register(Default Value: 0x00000000)**

Offset: 0x30			Register Name: <b>SMC_SPECU_CTRL_REG</b>
Bit	R/W	Default/Hex	Description
31:2	/	/	/
1	R/W	0x0	WRITE_SPECU. Write_speculation. Control the write access speculation: 0 = write access speculation is enabled 1 = write access speculation is disabled.
0	R/W	0x0	READ_SPECU. Read_speculation. Control the read access speculation: 0 = read access speculation is enabled 1 = read access speculation is disabled.

**4.17.4.13. SMC Security Inversion Enable Register(Default Value: 0x00000000)**

Offset: 0x34			Register Name: <b>SMC_SEC_INV_EN_REG</b>
Bit	R/W	Default/Hex	Description
31:1	/	/	/
0	R/W	0x0	SEC_INV_EN. Security_inversion_en. Controls whether the SMC permits security inversion to occur. 0 = security inversion is not permitted. 1 = security inversion is permitted. This enables a region to be accessible to masters in Non-secure state but not accessible to masters in Secure state. See Table 4-4 and Table 4-5.

**4.17.4.14. SMC Master Attribute Register(Default Value: 0x00000000)**

Offset: 0x48			Register Name: <b>SMC_MST_ATTRI_REG</b>
Bit	R/W	Default/Hex	Description
31:0	R/W	0x0	MST_ATTRI. 0: The secure attribute of master is up to master security extensions; 1: The secure attribute of master is up to <i>Master Secure Register</i> .

**4.17.4.15. DRM Master Enable Register(Default Value: 0x00000000)**

Offset: 0x50			Register Name: <b>DRM_MASTER_EN_REG</b>
Bit	R/W	Default/Hex	Description
31	R/W	0x0	DRM_EN. DRM enable.
30:12	/	/	/
13	R/W	0x0	GPU_WRITE_EN GPU write enable.
12	R/W	0x0	GPU_READ_EN GPU read enable.
11:8	/	/	/
7	R/W	0x0	DE_INTERLACE DE_INTERLACE enable.
6	R/W	0x0	DE_RT-WB DE_RT-WB enable.
5	R/W	0x0	DE_RT-MIXER1 DE_RT-MIXER1 enable.
4	R/W	0x0	DE_RT-MIXER0 DE_RT-MIXER0 enable.
3:1	/	/	/
0	R/W	0x0	VE_ENCODE_EN VE encode enable.

**4.17.4.16. DRM Illegal Access Register(Default Value: 0x00000000)**

Offset: 0x58			Register Name: <b>DRM_ILLACCE_REGO</b>
Bit	R/W	Default/Hex	Description
31:0	RO	0x0	DRM_ILLACCE_REG. When a master, which is non-secure, accesses the DRM space, then the relevant bit will be set up. See Table 4-2 for detail.



**4.17.4.17. DRM Start Address Register(Default Value: 0x00000000)**

Offset: 0x60			Register Name: <b>DRM_STATADDR_REG</b>
Bit	R/W	Default/Hex	Description
31:15	R/W	0x0	DRM_STATADDR_REG.
14:0	/	/	/

**4.17.4.18. DRM End Address Register(Default Value: 0x00000000)**

Offset: 0x68			Register Name: <b>DRM_ENDADDR_REG</b>
Bit	R/W	Default/Hex	Description
31:15	R/W	0x0	DRM_ENDADDR_REG.
14:0	/	/	/

**4.17.4.19. SMC Region Setup Low Register(Default Value: 0x00000000)**

Offset: 0x100+N*0x10(N=0~15)			Register Name: <b>SMC_REGION_SETUP_LO_REG</b>
Bit	R/W	Default/Hex	Description
31:15	R/W	0x0	<p>BASE_ADDRESS_LOW.</p> <p>Controls the base address [31:15] of region&lt;n&gt;.</p> <p>The SMC only permits a region to start at address 0x0, or at a multiple of its region size. For example, if the size of a region is 512MB, and it is not at address 0x0, the only valid settings for this field are:</p> <p>17'b00100000000000000000</p> <p>17'b01000000000000000000</p> <p>17'b01100000000000000000</p> <p>17'b10000000000000000000</p> <p>17'b10100000000000000000</p> <p>17'b11000000000000000000</p> <p>17'b11100000000000000000</p>
14:0	/	/	/

**Note1:**For region 0, this field is Read Only (RO). The SMC sets the base address of region 0 to 0x0.

**Note2:**The base address should be equal to the DRAM absolutely address.

**4.17.4.20. SMC Region Setup High Register(Default Value: 0x00000000)**

Offset: 0x104+N*0x10(N=0~15)			Register Name: <b>SMC_REGION_SETUP_HI_REG</b>
Bit	R/W	Default/Hex	Description
31:0	R/W	0x0	<p>BASE_ADDRESS_HIGH</p> <p>The SMC only permits a region to start at address 0x0, or at a multiple of its</p>

			region size. If you program a region size to be 8GB or more, then the SMC might ignore certain bits depending on the region size.
--	--	--	---

**4.17.4.21. SMC Region Attributes Register(Default Value: 0x00000000)**

Offset: 0x108+N*0x10(N=0~15)			Register Name: <b>SMC_REGION_ATTR_REG</b>
Bit	R/W	Default/Hex	Description
31:28	R/W	0x0	REGION_ATTR_SPN. SP<n>. Permission setting for region <n>. if an AXI transaction occurs to region n, the value in the sp<n> field controls whether the SMC permits the transaction to proceed. . See Table 4-4 and Table 4-5.
27:16	/	/	/.
15:8	R/W	0x0	SUB_REGION_DISABLE. Subregion_disable. Regions are split into eight equal-sized sub-regions, and each bit enables the corresponding subregion to be disabled. Bit [15] = 1 subregion 7 is disabled. Bit [14] = 1 subregion 6 is disabled. Bit [13] = 1 subregion 5 is disabled. Bit [12] = 1 subregion 4 is disabled. Bit [11] = 1 subregion 3 is disabled. Bit [10] = 1 subregion 2 is disabled. Bit [9] = 1 subregion 1 is disabled. Bit [8] = 1 subregion 0 is disabled.
7	/	/	/
6:1	R/W	0x0	REGION_ATTR_SIZE. Size<n>. Size of region<n>, see Table 3 for detail.
0	R/W	0x0	REGION_ATTR_EN. EN<n>. Enable for region<n>. 0 = region < n> is disabled. 1 = region < n> is enabled.

**Note:**For region 0,this field is reserved except SPN field.

## 4.18. Secure Memory Touch Arbiter

### 4.18.1. Overview

Secure Memory Touch Arbiter provides a software interface to the protection bits in a secure system in a TrustZone design. It provides system flexibility that enables to configure different areas of memory as secure or non-secure.

The SMTA includes the following features:

- It has protection bits to enable you to program some areas of memory as secure or non-secure.

### 4.18.2. Functionalities Description

#### 4.18.2.1. Typical Applications

The SMTA provides a software interface to set up memory areas as secure or non-secure. It does this in two ways:

- Programmable protection bits that can be allocated to areas of memory as determined by an external decoder
- Programmable region size value for use by an AXI TrustZone Memory Adapter.

#### 4.18.2.2. SMTA Configuration Table

The following table shows the configuration region of SMTA.

Table 4-6. SMTA Configuration Table

Register	Bit	SMTA0	SMTA1	SMTA2
		Module Name	Module Name	Module Name
SMTA DECPORTx (x=0,1,2)	[0]	/	NAND	VE SRAM
	[1]	I2C0	DMA	R_CPUCFG
	[2]	I2C1	Crypto Engine	System Control
	[3]	SPI0	SRAM A1	CCU
	[4]	SPI1	USB_OTG_Device	DE
	[5]	GPIO	USB Host0	RTC
	[6]	/	DRAMC	R_INTC
	[7]	SD/eMMC0	PRCM	

### 4.18.3. SMTA Register List

Module Name	Base Address
SMTA	0x01C23400

Register Name	Offset	Description
SMTA_DECPORT0_STA_REG	0x4	SMTA Decode Port0 Status Register
SMTA_DECPORT0_SET_REG	0x8	SMTA Decode Port0 Set Register
SMTA_DECPORT0_CLR_REG	0xC	SMTA Decode Port0 Clear Register
SMTA_DECPORT1_STA_REG	0x10	SMTA Decode Port1 Status Register
SMTA_DECPORT1_SET_REG	0x14	SMTA Decode Port1 Set Register
SMTA_DECPORT1_CLR_REG	0x18	SMTA Decode Port1 Clear Register
SMTA_DECPORT2_STA_REG	0x1C	SMTA Decode Port2 Status Register
SMTA_DECPORT2_SET_REG	0x20	SMTA Decode Port2 Set Register
SMTA_DECPORT2_CLR_REG	0x24	SMTA Decode Port2 Clear Register

### 4.18.4. SMTA Register Description

#### 4.18.4.1. SMTA DECPORT0 Status Register(Default Value: 0x00000000)

Offset: 0x4			Register Name: <b>SMTA_DECPORT0_STA_REG</b>
Bit	R/W	Default/Hex	Description
31:8	/	/	/
7:0	RO	0x0	STA_DEC_PROTO_OUT. Show the status of the decode protection output: 0: = Decode region corresponding to the bit is secure 1: = Decode region corresponding to the bit is non-secure. There is one bit of the register for each protection output (See the SMTA Configuration Table4-6 in detail).

#### 4.18.4.2. SMTA DECPORT0 Set Register(Default Value: 0x00000000)

Offset: 0x8			Register Name: <b>SMTA_DECPORT0_SET_REG</b>
Bit	R/W	Default/Hex	Description
31:8	/	/	/.
7:0	WO	0x0	SET_DEC_PORT0_OUT. Sets the corresponding decode protection output: 0: = No effect 1: = Set decode region to non-secure. There is one bit of the register for each protection output (See the SMTA

			Configuration Table4-6 in detail).
--	--	--	------------------------------------

#### 4.18.4.3. SMTA DECPORT0 Clear Register(Default Value: 0x00000000)

Offset: 0xC			Register Name: <b>SMTA_DECPORT0_CLR_REG</b>
Bit	R/W	Default/Hex	Description
31:8	/	/	/
7:0	WO	0x0	CLR_DEC_PROTO_OUT. Clears the corresponding decode protection output: 0: = No effect 1: = Set decode region to secure. There is one bit of the register for each protection output (See the SMTA Configuration Table4-6 in detail).

#### 4.18.4.4. SMTA DECPORT1 Status Register(Default Value: 0x00000000)

Offset: 0x10			Register Name: <b>SMTA_DECPORT1_STA_REG</b>
Bit	R/W	Default/Hex	Description
31:8	/	/	/
7:0	RO	0x0	STA_DEC_PROT1_OUT. Show the status of the decode protection output: 0: = Decode region corresponding to the bit is secure 1: = Decode region corresponding to the bit is non-secure. There is one bit of the register for each protection output (See the SMTA Configuration Table4-6 in detail).

#### 4.18.4.5. SMTA DECPORT1 Set Register(Default Value: 0x00000000)

Offset: 0x14			Register Name: <b>SMTA_DECPORT1_SET_REG</b>
Bit	R/W	Default/Hex	Description
31:8	/	/	/
7:0	WO	0x0	SET_DEC_PORT1_OUT. Sets the corresponding decode protection output: 0: = No effect 1: = Set decode region to non-secure. There is one bit of the register for each protection output (See the SMTA Configuration Table4-6 in detail).

**4.18.4.6. SMTA DECPORT1 Clear Register(Default Value: 0x00000000)**

Offset: 0x18			Register Name: <b>SMTA_DECPORT1_CLR_REG</b>
Bit	R/W	Default/Hex	Description
31:8	/	/	/
7:0	WO	0x0	CLR_DEC_PROT1_OUT. Clears the corresponding decode protection output: 0: = No effect 1: = Set decode region to secure. There is one bit of the register for each protection output (See the SMTA Configuration Table4-6 in detail).

**4.18.4.7. SMTA DECPORT2 Status Register(Default Value: 0x00000000)**

Offset: 0x1C			Register Name: <b>SMTA_DECPORT2_STA_REG</b>
Bit	R/W	Default/Hex	Description
31:8	/	/	/
7:0	RO	0x0	STA_DEC_PROT2_OUT. Show the status of the decode protection output: 0: = Decode region corresponding to the bit is secure 1: = Decode region corresponding to the bit is non-secure. There is one bit of the register for each protection output (See the SMTA Configuration Table4-6 in detail).

**4.18.4.8. SMTA DECPORT2 Set Register(Default Value: 0x00000000)**

Offset: 0x20			Register Name: <b>SMTA_DECPORT2_SET_REG</b>
Bit	R/W	Default/Hex	Description
31:8	/	/	/
7:0	WO	0x0	SET_DEC_PORT2_OUT. Sets the corresponding decode protection output: 0: = No effect 1: = Set decode region to non-secure. There is one bit of the register for each protection output (See the SMTA Configuration Table4-6 in detail).

**4.18.4.9. SMTA DECPORT2 Clear Register(Default Value: 0x00000000)**

Offset: 0x24			Register Name: <b>SMTA_DECPORT2_CLR_REG</b>
Bit	R/W	Default/Hex	Description

31:8	/	/	/
7:0	WO	0x0	<p>CLR_DEC_PROT2_OUT.</p> <p>Clears the corresponding decode protection output:</p> <p>0: = No effect</p> <p>1: = Set decode region to secure.</p> <p>There is one bit of the register for each protection output (See the SMTA Configuration Table4-6 in detail).</p>

Confidential

## 4.19. Thermal Sensor Controller

### 4.19.1. Overview

The thermal sensors have become common elements in wide range of modern system on chip (SOC) platform. Thermal sensors are used to constantly monitor the temperature on the chip.

H3 embeds one thermal sensor located in the CPU .The thermal sensor Generates interrupt to SW to lower temperature via DVFS, on reaching a certain thermal threshold.

The Thermal Sensor Controller includes the following features:

- Supports APB 32-bits bus width
- Power supply voltage:3.0V
- Low power dissipation
- Periodic temperature measurement
- Averaging filter for thermal sensor reading
- Support over-temperature protection interrupt and over-temperature alarm interrupt

### 4.19.2. Clock and Timing Requirements

CLK\_IN = 24MHz/M, M can be set in the CCU

Conversion Time =  $1/(24\text{MHz}/M/14\text{Cycles}) = 0.583 * M$  (us)

THERMAL\_PER (configured by the value of THERMAL\_PER) is must be greater than (ACQ1 + ACQ0+Conversion Time)

$$\text{THERMAL\_PER} > \text{ACQ1} + \text{ACQ0} + \text{Conversion Time}$$

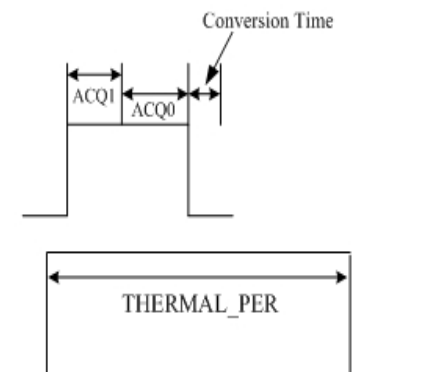

Figure 4-13. Thermal Conversion phase

### 4.19.3. Thermal Sensor Register List

Module Name	Base Address
-------------	--------------



Thermal Sensor	0x01C25000
----------------	------------

Register Name	Offset	Description
THS_CTRL0	0x00	THS Control Register0
THS_CTRL1	0x04	THS Control Register1
ADC_CDAT	0x14	ADC calibration data Register
THS_CTRL2	0x40	THS Control Register2
THS_INT_CTRL	0x44	THS Interrupt Control Register
THS_STAT	0x48	THS Status Register
THS_ALARM_CTRL	0x50	Alarm threshold Control Register
THS_SHUTDOWN_CTRL	0x60	Shutdown threshold Control Register
THS_FILTER	0x70	Median filter Control Register
THS_CDATA	0x74	Thermal Sensor Calibration Data
THS_DATA	0x80	THS Data Register

#### 4.19.4. Thermal Sensor Register Description

##### 4.19.4.1. THS Control Register0 (Default Value: 0x00000000)

Offset: 0x00			Register Name: THS_CTRL_REG0
Bit	R/W	Default/Hex	Description
31:16	/	/	/
15:0	R/W	0x0	SENSOR_ACQ0 ADC acquire time CLK_IN/(N+1)

##### 4.19.4.2. THS Control Register1 (Default Value: 0x00000000)

Offset: 0x04			Register Name: THS_CTRL_REG1
Bit	R/W	Default/Hex	Description
31:22	/	/	/
21:20	R/W	0x0	THS_OP_BIAS. THS OP Bias
19:18	/	/	/
17	R/W	0x0	ADC_CALI_EN. ADC Calibration 1: start Calibration, it is clear to 0 after calibration
16:0	/	/	/

**4.19.4.3. ADC calibration Data Register (Default Value: 0x00000000)**

Offset: 0x14			Register Name: <b>ADC_CDAT_REG</b>
Bit	R/W	Default/Hex	Description
31:12	/	/	/
11:0	R/W	0xxxx	ADC_CDAT. ADC calibration data

**4.19.4.4. THS Control Register2 (Default Value: 0x00040000)**

Offset: 0x40			Register Name: <b>THS_CTRL_REG2</b>
Bit	R/W	Default/Hex	Description
31:16	R/W	0x4	SENSOR_ACQ1. Sensor acquire time $CLK\_IN/(N+1)$
15:3	/	/	/
2	/	/	/
1	/	/	/
0	R/W	0x0	SENSE_EN. Enable temperature measurement sensor 0:Disable 1:Enable

**4.19.4.5. THS Interrupt Control Register (Default Value: 0x00000000)**

Offset: 0x44			Register Name: <b>THS_INT_CTRL_REG</b>
Bit	R/W	Default/Hex	Description
31:12	R/W	0x0	THERMAL_PER. $4096*(n+1)/CLK\_IN$
11	/	/	/
10	/	/	/
9	/	/	/
8	R/W	0x0	THS_DATA_IRQ_EN. Selects Temperature measurement data of sensor 0: No select 1: Select
7	/	/	/
6	/	/	/
5	/	/	/
4	R/W	0x0	SHUT_INT_EN. Selects shutdown interrupt for sensor

			0: No select 1: Select
3	/	/	/
2	/	/	/
1	/	/	/
0	R/W	0x0	ALARM_INT_EN. Selects Alert interrupt for sensor 0: No select 1: Select

#### 4.19.4.6. THS status Register (Default Value: 0x00000000)

Offset: 0x48			Register Name: THS_STAT_REG
Bit	R/W	Default/Hex	Description
31:15	/	/	/
14	/	/	/
13	/	/	/
12	R/W	0x0	ALARM_OFF_STS. Alarm interrupt off pending for sensor Write '1' to clear this interrupt or automatic clear if interrupt condition fails
11	/	/	/
10	/	/	/
9	/	/	/
8	R/W	0x0	THS_DATA_IRQ_STS. Data interrupt status for sensor Write '1' to clear this interrupt or automatic clear if interrupt condition fails
7	/	/	/
6	/	/	/
5	/	/	/
4	R/W	0x0	SHUT_INT_STS. Shutdown interrupt status for sensor Write '1' to clear this interrupt or automatic clear if interrupt condition fails
3	/	/	/
2	/	/	/
1	/	/	/
0	R/W	0x0	ALARM_INT_STS. Alarm interrupt pending for sensor Write '1' to clear this interrupt or automatic clear if interrupt condition fails

**4.19.4.7. Alarm threshold Control Register (Default Value: 0x05a00684)**

Offset: 0x50			Register Name: THS0_ALARM_CTRL_REG
Bit	R/W	Default/Hex	Description
31:28	/	/	/
27:16	R/W	0x5A0	ALARM0_T_HOT. Thermal sensor0 Alarm Threshold for hot temperature
15:12	/	/	/
11:0	R/W	0x684	ALARM0_T_HYST Thermal sensor0 Alarm threshold for hysteresis temperature

**4.19.4.8. Shutdown threshold Control Register (Default Value: 0x04e90000)**

Offset: 0x60			Register Name: THS_SHUTDOWN_CTRL_REG
Bit	R/W	Default/Hex	Description
31:28	/	/	/
27:16	R/W	0x4E9	SHUT0_T_HOT. Thermal sensor0 Shutdown Threshold for hot temperature
15:0	/	/	/

**4.19.4.9. Average filter Control Register (Default Value: 0x00000001)**

Offset: 0x70			Register Name: THS_FILTER_REG
Bit	R/W	Default/Hex	Description
31:3	/	/	/
2	R/W	0x0	FILTER_EN. Filter Enable 0: Disable 1: Enable
1:0	R/W	0x1	FILTER_TYPE. Average Filter Type 00: 2 01: 4 10: 8 11: 16

**4.19.4.10. Thermal Sensor calibration Data Register (Default Value: 0x00000800)**

Offset: 0x74			Register Name: THS_CDATA_REG
Bit	R/W	Default/Hex	Description

31:28	/	/	/
27:16	/	/	/
15:12	/	/	/
11:0	R/W	0x800	THS_CDATA. Thermal Sensor calibration data

#### 4.19.4.11. THS Data Register (Default Value: 0x00000000)

Offset: 0x80			Register Name: <b>THS_DATA_REG</b>
Bit	R/W	Default/Hex	Description
31:12	/	/	/
11:0	R	0x0	THS_DATA. Temperature measurement data of sensor

#### 4.19.5. Programming Guidelines

- 1) Timing must be like this: THERMAL\_PER > ACQ1 + ACQ0+Conversion Time
- 2) Configure THS Interrupt Control Register to set the THERMAL\_PER and IRQ
- 3) Configure the Alarm threshold Control Register and Shutdown threshold Control Register to set the ALARM\_T\_HOT and SHUT\_T\_HOT
- 4) Configure THS Control Register to set the SENSOR\_ACQ and enable the sensor
- 5) The real temperature value of each sensor is Tem, then

$$T = (Tem - 2794) / -14.882$$

Reading back the temperature from the temperature value register requires a 2-byte read. Use 12-bit temperature data format.

## 4.20. KEY\_ADC

### 4.20.1. Overview

KEY\_ADC is 6-bit resolution ADC for key application. The KEY\_ADC can work up to 250Hz conversion rate.

The KEY\_ADC includes the following features:

- Supports APB 32-bits bus width,reference voltage is 2.0V
- Support interrupt
- Support Hold Key and General Key
- Support Single Key and Continue Key mode
- Support 6-bits resolution
- Voltage input range between 0V to 2.0V
- Sample rate up to 250Hz

### 4.20.2. Operation Principle

The KEY\_ADC converted data can accessed by interrupt and polling method. If software can't access the last converted data instantly, the new converted data would update the old one at new sampling data.

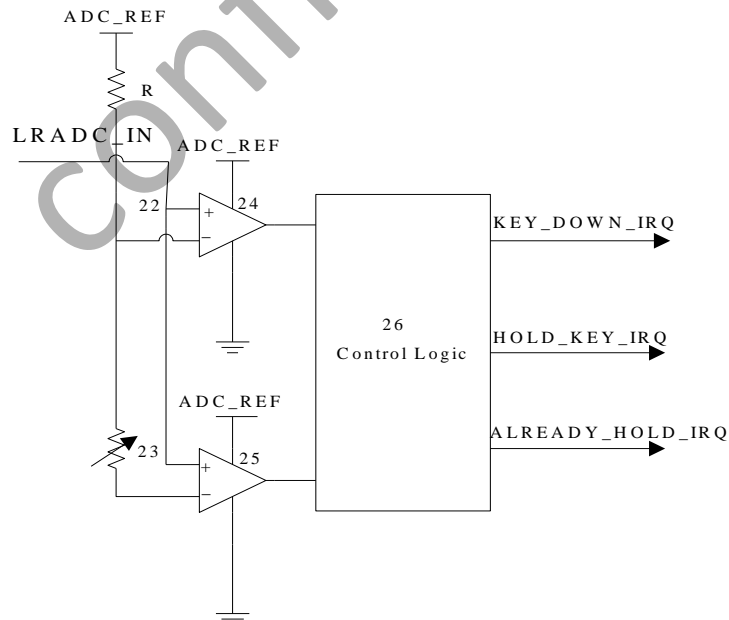

Figure 4-14. KEY\_ADC Converted Data Diagram

When ADC\_IN Signal change from 1.8V to less than 1.35V (Level A), the comparator24 send first interrupt to control logic; When ADC\_IN Signal change from 1.35V to less than certain level (Program can set), the comparator25 give second interrupt. If the control Logic get the first interrupt, In a certain time range (program can set), doesn't get

second interrupt, it will send hold key interrupt to the host; If the control Logic get the first interrupt, In a certain time range (program can set), get second interrupt, it will send key down interrupt to the host; If the control logic only get the second interrupt, doesn't get the first interrupt, it will send already hold interrupt to the host.

The KEY\_ADC have three mode, Normal Mode、Single Mode and Continue Mode. Normal mode is that the KEY\_ADC will report the result data of each convert all the time when the key is down. Single Mode is that the KEY\_ADC will only report the first convert result data when the key is down. Continue Mode is that the KEY\_ADC will report one of  $8*(N+1)$  (N is program can set) sample convert result data when key is down.

The KEY\_ADC is support four sample rate such as 250Hz、125Hz、62.5Hz and 32.25Hz, you can configure the value of KEY\_ADC\_SAMPLE\_RATE to select the fit sample rate.

### 4.20.3. KEY\_ADC Register List

Module Name	Base Address
KEY_ADC	0x01C21800

Register Name	Offset	Description
KEY_ADC_CTRL	0x00	KEY_ADC Control Register
KEY_ADC_INTC	0x04	KEY_ADC Interrupt Control Register
KEY_ADC_INTS	0x08	KEY_ADC Interrupt Status Register
KEY_ADC_DATA	0x0C	KEY_ADC Data Register

### 4.20.4. KEY\_ADC Register Description

#### 4.20.4.1. KEY\_ADC Control Register (Default Value: 0x01000168)

Offset: 0x00			Register Name: KEY_ADC_CTRL_REG
Bit	R/W	Default/Hex	Description
31: 24	R/W	0x1	FIRST_CONVERT_DLY. ADC First Convert Delay setting, ADC conversion is delayed by n samples
23:22	R/W	0x0	Reserved to 0
21:20	/	/	/
19:16	R/W	0x0	CONTINUE_TIME_SELECT. Continue Mode time select, one of $8*(N+1)$ sample as a valuable sample data
15:14	/	/	/
13:12	R/W	0x0	KEY_MODE_SELECT. Key Mode Select: 00: Normal Mode 01: Single Mode

			10: Continue Mode
11:8	R/W	0x1	LEVELA_B_CNT. Level A to Level B time threshold select, judge ADC convert value in level A to level B in n+1 samples
7	R/W	0x0	KEY_ADC_HOLD_KEY_EN KEY_ADC Hold Key Enable 0: Disable 1: Enable
6	R/W	0x1	KEY_ADC_HOLD_EN. KEY_ADC Sample hold Enable 0: Disable 1: Enable
5: 4	R/W	0x2	LEVELB_VOL. Level B Corresponding Data Value setting (the real voltage value) 00: 0x3C (~1.9v) 01: 0x39 (~1.8v) 10: 0x36 (~1.7v) 11: 0x33 (~1.6v)
3: 2	R/W	0x2	KEY_ADC_SAMPLE_RATE. KEY_ADC Sample Rate 00: 250 Hz 01: 125 Hz 10: 62.5 Hz 11: 32.25 Hz
1	/	/	/
0	R/W	0x0	KEY_ADC_EN. KEY_ADC enable 0: Disable 1: Enable

#### 4.20.4.2. KEY\_ADC Interrupt Control Register (Default Value: 0x00000000)

Offset: 0x04			Register Name: <b>KEY_ADC_INTC_REG</b>
Bit	R/W	Default/Hex	Description
31:5	/	/	/
4	R/W	0x0	ADC_KEYUP_IRQ_EN. ADC Key Up IRQ Enable 0: Disable 1: Enable
3	R/W	0x0	ADC_ALRDY_HOLD_IRQ_EN. ADC Already Hold IRQ Enable 0: Disable 1: Enable
2	R/W	0x0	ADC_HOLD_IRQ_EN.



			ADC Hold Key IRQ Enable 0: Disable 1: Enable
1	R/W	0x0	ADC_KEYDOWN_EN ADC Key Down Enable 0: Disable 1: Enable
0	R/W	0x0	ADC_DATA_IRQ_EN. ADC Data IRQ Enable 0: Disable 1: Enable

#### 4.20.4.3. KEY\_ADC Interrupt Status Register (Default Value: 0x00000000)

Offset: 0x08			Register Name:KEY_ADC_INTS_REG
Bit	R/W	Default/Hex	Description
31:5	/	/	/
4	R/W	0x0	ADC_KEYUP_PENDING. ADC Key up pending Bit When general key pull up, it the corresponding interrupt is enabled. 0: No IRQ 1: IRQ Pending Notes: Writing 1 to the bit will clear it and its corresponding interrupt if the interrupt is enable
3	R/W	0x0	ADC_ALRDY_HOLD_PENDING. ADC Already Hold Pending Bit When hold key pull down and pull the general key down, if the corresponding interrupt is enabled. 0: No IRQ 1: IRQ Pending Notes: Writing 1 to the bit will clear it and its corresponding interrupt if the interrupt is enable
2	R/W	0x0	ADC_HOLDKEY_PENDING. ADC Hold Key pending Bit When Hold key pull down, the status bit is set and the interrupt line is set if the corresponding interrupt is enabled. 0: NO IRQ 1: IRQ Pending Notes: Writing 1 to the bit will clear it and its corresponding interrupt if the interrupt is enable.
1	R/W	0x0	ADC_KEYDOWN_PENDING. ADC Key Down IRQ Pending Bit When General key pull down, the status bit is set and the interrupt line is set if the corresponding interrupt is enabled.

			0: No IRQ 1: IRQ Pending Notes: Writing 1 to the bit will clear it and its corresponding interrupt if the interrupt is enable.
0	R/W	0x0	ADC_DATA_PENDING. ADC Data IRQ Pending Bit 0: No IRQ 1: IRQ Pending Notes: Writing 1 to the bit will clear it and its corresponding interrupt if the interrupt is enable.

#### 4.20.4.4. KEY\_ADC Data Register (Default Value: 0x00000000)

Offset: 0x0C			Register Name: <b>KEY_ADC_DATA_REG</b>
Bit	R/W	Default/Hex	Description
31:6	/	/	/
5:0	R	0x0	KEY_ADC_DATA. KEY_ADC Data

Confidential

## 4.21. Audio Codec

### 4.21.1. Overview

The embedded Audio Codec is a high-quality stereo audio codec designed for embed device. It provides a stereo DAC for playback, and a stereo ADC for recording.

The features of Audio Codec:

- Two audio digital-to-analog(DAC) channels
- Support analog/ digital volume control
- One low-noise analog microphone bias output
- Analog low-power loop from line-in /microphone to lineout outputs
- Support Dynamic Range Controller adjusting the DAC playback output
- Three audio inputs:
  - Two differential microphone inputs
  - Stereo line-in input
- Two audio analog-to-digital(ADC) channels
  - 92dB SNR@A-weight
  - Supports ADC Sample Rates from 8KHz to 48KHz
- Support Automatic Gain Control(AGC) and Dynamic Range Control(DRC) adjusting the ADC recording output
- Interrupt and DMA Support

### 4.21.2. Power and Signal Description

#### 4.21.2.1. Analog I/O Pins

Signal Name	Type	Description
MIC1P	I	First microphone positive input
MIC1N	I	First microphone negative input
MIC2P	I	Second microphone positive input
MIC2N	I	Second microphone negative input
LINEINL	I	Line in left input
LINEINR	I	Line in right input
LINEOUTL	O	Line out left output
LINEOUTR	O	Line out right output

4.21.2.2. Filter/Reference

MBIAS	O	Bias voltage output for main microphone
VRA1	O	internal reference voltage
VRA2	O	internal reference voltage
VRP	O	internal reference voltage

4.21.2.3. Power/Ground

AVCC	P	Analog power
AGND	G	Analog ground

4.21.3. Data Path Diagram

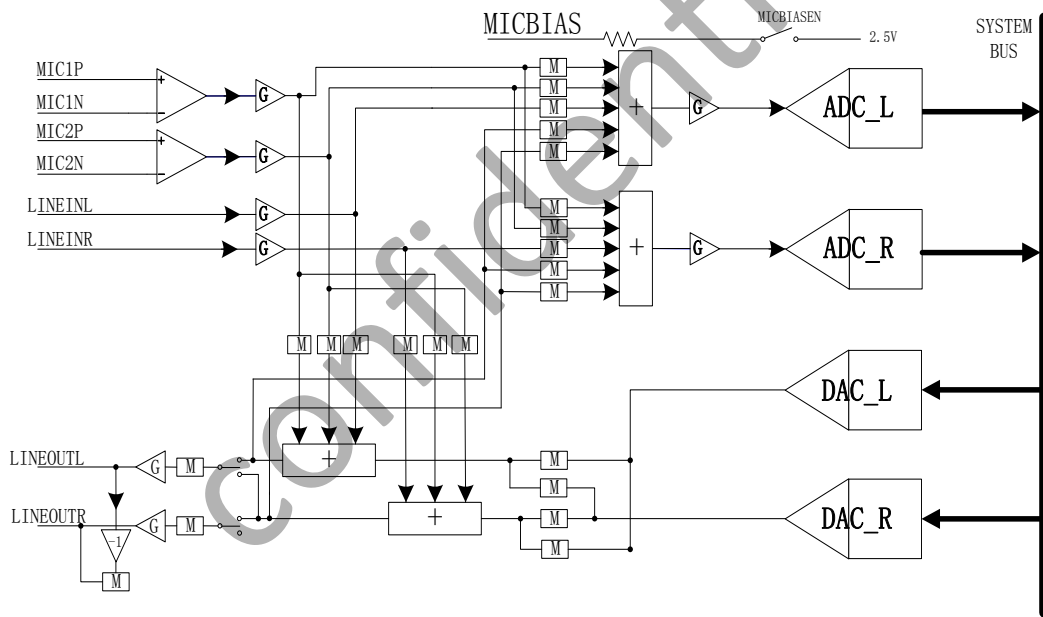

Figure 4-15. Audio Codec Data Path Diagram

4.21.4. Audio Codec Register List

Module Name	Base Address
AC	0X01C22C00

Register Name	Offset	Description
AC_DAC_DPC	0x000	DAC Digital Part Control Register
AC_DAC_FIFOC	0x004	DAC FIFO Control Register

AC_DAC_FIFOS	0x008	DAC FIFO Status Register
AC_ADC_FIFOC	0x010	ADC FIFO Control Register
AC_ADC_FIFOS	0x014	ADC FIFO Status Register
AC_ADC_RXDATA	0x018	ADC RX Data Register
AC_DAC_TXDATA	0x020	DAC TX Data Register
AC_DAC_CNT	0x040	DAC TX FIFO Counter Register
AC_ADC_CNT	0x044	ADC RX FIFO Counter Register
AC_DAC_DG	0x048	DAC Debug Register
AC_ADC_DG	0x04C	ADC Debug Register
AC_DAC_DAP_CTR	0x060	DAC DAP Control Register
AC_ADC_DAP_CTR	0x070	ADC DAP Control Register
AC_ADC_DAP_LCTR	0x074	ADC DAP Left Control Register
AC_ADC_DAP_RCTR	0x078	ADC DAP Right Control Register
AC_ADC_DAP_PARA	0x07C	ADC DAP Parameter Register
AC_ADC_DAP_LAC	0x080	ADC DAP Left Average Coef Register
AC_ADC_DAP_LDAT	0x084	ADC DAP Left Decay and Attack Time Register
AC_ADC_DAP_RAC	0x088	ADC DAP Right Average Coef Register
AC_ADC_DAP_RDAT	0x08C	ADC DAP Right Decay and Attack Time Register
AC_ADC_DAP_HPFC	0x090	ADC DAP HPF Coef Register
AC_ADC_DAP_LINAC	0x094	ADC DAP Left Input Signal Low Average Coef Register
AC_ADC_DAP_RINAC	0x098	ADC DAP Right Input Signal Low Average Coef Register
AC_ADC_DAP_ORT	0x09c	ADC DAP Optimum Register
AC_DAC_DRC_HHPFC	0x100	DAC DRC High HPF Coef Register
AC_DAC_DRC_LHPFC	0x104	DAC DRC Low HPF Coef Register
AC_DAC_DRC_CTRL	0x108	DAC DRC Control Register
AC_DAC_DRC_LPFHAT	0x10C	DAC DRC Left Peak Filter High Attack Time Coef Register
AC_DAC_DRC_LPFLAT	0x110	DAC DRC Left Peak Filter Low Attack Time Coef Register
AC_DAC_DRC_RPFHAT	0x114	DAC DRC Right Peak Filter High Attack Time Coef Register
AC_DAC_DRC_RPFLAT	0x118	DAC DRC Peak Filter Low Attack Time Coef Register
AC_DAC_DRC_LPFHRT	0x11C	DAC DRC Left Peak Filter High Release Time Coef Register
AC_DAC_DRC_LPFLRT	0x120	DAC DRC Left Peak Filter Low Release Time Coef Register
AC_DAC_DRC_RPFHRT	0x124	DAC DRC Right Peak filter High Release Time Coef Register
AC_DAC_DRC_RPFLRT	0x128	DAC DRC Right Peak filter Low Release Time Coef Register
AC_DAC_DRC_LRMSHAT	0x12C	DAC DRC Left RMS Filter High Coef Register
AC_DAC_DRC_LRMSLAT	0x130	DAC DRC Left RMS Filter Low Coef Register
AC_DAC_DRC_RRMSHAT	0x134	DAC DRC Right RMS Filter High Coef Register
AC_DAC_DRC_RRMSLAT	0x138	DAC DRC Right RMS Filter Low Coef Register
AC_DAC_DRC_HCT	0x13C	DAC DRC Compressor Theshold High Setting Register
AC_DAC_DRC_LCT	0x140	DAC DRC Compressor Slope High Setting Register

AC_DAC_DRC_HKC	0x144	DAC DRC Compressor Slope High Setting Register
AC_DAC_DRC_LKC	0x148	DAC DRC Compressor Slope Low Setting Register
AC_DAC_DRC_HOPC	0x14C	DAC DRC Compressor High Output at Compressor Threshold Register
AC_DAC_DRC_LOPC	0x150	DAC DRC Compressor Low Output at Compressor Threshold Register
AC_DAC_DRC_HLT	0x154	DAC DRC Limiter Theshold High Setting Register
AC_DAC_DRC_LLT	0x158	DAC DRC Limiter Theshold Low Setting Register
AC_DAC_DRC_HKI	0x15C	DAC DRC Limiter Slope High Setting Register
AC_DAC_DRC_LKI	0x160	DAC DRC Limiter Slope Low Setting Register
AC_DAC_DRC_HOPL	0x164	DAC DRC Limiter High Output at Limiter Threshold
AC_DAC_DRC_LOPL	0x168	DAC DRC Limiter Low Output at Limiter Threshold
AC_DAC_DRC_HET	0x16C	DAC DRC Expander Theshold High Setting Register
AC_DAC_DRC_LET	0x170	DAC DRC Expander Theshold Low Setting Register
AC_DAC_DRC_HKE	0x174	DAC DRC Expander Slope High Setting Register
AC_DAC_DRC_LKE	0x178	DAC DRC Expander Slope Low Setting Register
AC_DAC_DRC_HOPE	0x17C	DAC DRC Expander High Output at Expander Threshold
AC_DAC_DRC_LOPE	0x180	DAC DRC Expander Low Output at Expander Threshold
AC_DAC_DRC_HKN	0x184	DAC DRC Linear Slope High Setting Register
AC_DAC_DRC_LKN	0x188	DAC DRC Linear Slope Low Setting Register
AC_DAC_DRC_SFHAT	0x18C	DAC DRC Smooth filter Gain High Attack Time Coef Register
AC_DAC_DRC_SFLAT	0x190	DAC DRC Smooth filter Gain Low Attack Time Coef Register
AC_DAC_DRC_SFHRT	0x194	DAC DRC Smooth filter Gain High Release Time Coef Register
AC_DAC_DRC_SFLRT	0x198	DAC DRC Smooth filter Gain Low Release Time Coef Register
AC_DAC_DRC_MXGHS	0x19C	DAC DRC MAX Gain High Setting Register
AC_DAC_DRC_MXGLS	0x1A0	DAC DRC MAX Gain Low Setting Register
AC_DAC_DRC_MNGHS	0x1A4	DAC DRC MIN Gain High Setting Register
AC_DAC_DRC_MNGLS	0x1A8	DAC DRC MIN Gain Low Setting Register
AC_DAC_DRC_EPSHC	0x1AC	DAC DRC Expander Smooth Time High Coef Register
AC_DAC_DRC_EPSLC	0x1B0	DAC DRC Expander Smooth Time Low Coef Register
AC_DAC_DRC_OPT	0x1B4	DAC DRC Optimum Register
AC_DAC_DRC_HPFHGAIN	0x1B8	DAC DRC HPF Gain High Coef Register
AC_DAC_DRC_HPFLGAIN	0x1BC	DAC DRC HPF Gain Low Coef Register
AC_ADC_DRC_HHPFC	0x200	ADC DRC High HPF Coef Register
AC_ADC_DRC_LHPFC	0x204	ADC DRC Low HPF Coef Register
AC_ADC_DRC_CTRL	0x208	ADC DRC Control Register
AC_ADC_DRC_LPFHAT	0x20C	ADC DRC Left Peak Filter High Attack Time Coef Register
AC_ADC_DRC_LPFLAT	0x210	ADC DRC Left Peak Filter Low Attack Time Coef Register
AC_ADC_DRC_RPFHAT	0x214	ADC DRC Right Peak Filter High Attack Time Coef Register
AC_ADC_DRC_RPFLAT	0x218	ADC DRC Peak Filter Low Attack Time Coef Register
AC_ADC_DRC_LPFHRT	0x21C	ADC DRC Left Peak Filter High Release Time Coef Register
AC_ADC_DRC_LPFLRT	0x220	ADC DRC Left Peak Filter Low Release Time Coef Register

AC_ADC_DRC_RPFHRT	0x224	ADC DRC Right Peak filter High Release Time Coef Register
AC_ADC_DRC_RPFLRT	0x228	ADC DRC Right Peak filter Low Release Time Coef Register
AC_ADC_DRC_LRMSHAT	0x22C	ADC DRC Left RMS Filter High Coef Register
AC_ADC_DRC_LRMSLAT	0x230	ADC DRC Left RMS Filter Low Coef Register
AC_ADC_DRC_RRMSHAT	0x234	ADC DRC Right RMS Filter High Coef Register
AC_ADC_DRC_RRMSLAT	0x238	ADC DRC Right RMS Filter Low Coef Register
AC_ADC_DRC_HCT	0x23C	ADC DRC Compressor Theshold High Setting Register
AC_ADC_DRC_LCT	0x240	ADC DRC Compressor Slope High Setting Register
AC_ADC_DRC_HKC	0x244	ADC DRC Compressor Slope High Setting Register
AC_ADC_DRC_LKC	0x248	ADC DRC Compressor Slope Low Setting Register
AC_ADC_DRC_HOPC	0x24C	ADC DRC Compressor High Output at Compressor Threshold Register
AC_ADC_DRC_LOPC	0x250	ADC DRC Compressor Low Output at Compressor Threshold Register
AC_ADC_DRC_HLT	0x254	ADC DRC Limiter Theshold High Setting Register
AC_ADC_DRC_LLT	0x258	ADC DRC Limiter Theshold Low Setting Register
AC_ADC_DRC_HKI	0x25C	ADC DRC Limiter Slope High Setting Register
AC_ADC_DRC_LKI	0x260	ADC DRC Limiter Slope Low Setting Register
AC_ADC_DRC_HOPL	0x264	ADC DRC Limiter High Output at Limiter Threshold
AC_ADC_DRC_LOPL	0x268	ADC DRC Limiter Low Output at Limiter Threshold
AC_ADC_DRC_HET	0x26C	ADC DRC Expander Theshold High Setting Register
AC_ADC_DRC_LET	0x270	ADC DRC Expander Theshold Low Setting Register
AC_ADC_DRC_HKE	0x274	ADC DRC Expander Slope High Setting Register
AC_ADC_DRC_LKE	0x278	ADC DRC Expander Slope Low Setting Register
AC_ADC_DRC_HOPE	0x27C	ADC DRC Expander High Output at Expander Threshold
AC_ADC_DRC_LOPE	0x280	ADC DRC Expander Low Output at Expander Threshold
AC_ADC_DRC_HKN	0x284	ADC DRC Linear Slope High Setting Register
AC_ADC_DRC_LKN	0x288	ADC DRC Linear Slope Low Setting Register
AC_ADC_DRC_SFHAT	0x28C	ADC DRC Smooth filter Gain High Attack Time Coef Register
AC_ADC_DRC_SFLAT	0x290	ADC DRC Smooth filter Gain Low Attack Time Coef Register
AC_ADC_DRC_SFHRT	0x294	ADC DRC Smooth filter Gain High Release Time Coef Register
AC_ADC_DRC_SFLRT	0x298	ADC DRC Smooth filter Gain Low Release Time Coef Register
AC_ADC_DRC_MXGHS	0x29C	ADC DRC MAX Gain High Setting Register
AC_ADC_DRC_MXGLS	0x2A0	ADC DRC MAX Gain Low Setting Register
AC_ADC_DRC_MNGLS	0x2A4	ADC DRC MIN Gain High Setting Register
AC_ADC_DRC_MXGLS	0x2A8	ADC DRC MIN Gain Low Setting Register
AC_ADC_DRC_EPSHC	0x2AC	ADC DRC Expander Smooth Time High Coef Register
AC_ADC_DRC_EPSLC	0x2B0	ADC DRC Expander Smooth Time Low Coef Register
AC_ADC_DRC_OPT	0x2B4	ADC DRC Optimum Register
AC_ADC_DRC_HPFHGAIN	0x2B8	ADC DRC HPF Gain High Coef Register
AC_ADC_DRC_HPFLGAIN	0x2BC	ADC DRC HPF Gain Low Coef Register
<b>Analog Domain Register</b>		

AC_PR_CFG		AC Parameter Configuration Register (0X01F015C0)
LINEOUT_PA_GAT	0X00	LINEOUT PA Gating Control Register
LOMIXSC	0X01	Left Output Mixer Source Select Control Register
ROMIXSC	0X02	Right Output Mixer Source Select Control Register
DAC_PA_SCR	0X03	DAC Analog Enable And PA Source Control Register
LINEIN_GCTR	0X05	Linein Gain Control Register
MIC_GCTR	0X06	MIC1 And MIC2 Gain Control Register
PAEN_CTR	0X07	PA Enable And LINEOUT Control Register
LINEOUT_VOLC	0X09	LINEOUT Volume Control Register
MIC2G_LINEOUT_CTR	0X0A	MIC2 Boost And LINEOUT Enable Control Register
MIC1G_MICBAIS_CTR	0X0B	MIC1 Boost And MICBIAS Control Register
LADCMIXSC	0X0C	Left ADC Mixer Source Control Register
RADCMIXSC	0X0D	Right Mixer Source Control Register
RES_REG	0X0E	Reserved Register
ADC_AP_EN	0X0F	ADC Analog Part Enable Register
ADDA_APT0	0X10	ADDA Analog Performance Turning0 Register
ADDA_APT1	0X11	ADDA Analog Performance Turning1 Register
ADDA_APT2	0X12	ADDA Analog Performance Turning2 Register
BIAS_DA16_CTR0	0X13	Bias & DA16 Calibration Control Register0
BIAS_DA16_CTR1	0x14	Bias & DA16 Calibration Control Register1
DA16CAL	0X15	DA16 Calibration Data Register
DA16VERIFY	0X16	DA16 Register Setting Data Register
BIASCALI	0X17	BIAS Calibration Data Register
BIASVERIFY	0X18	BIAS Register Setting Data Register

#### 4.21.5. Audio Codec Register Description

##### 4.21.5.1. 0x00 DAC Digital Part Control Register(Default Value: 0x00000000)

Offset: 0x00			Register Name: AC_DAC_DPC
Bit	R/W	Default/Hex	Description
31	R/W	0x0	EN_DAC DAC Digital Part Enable 0 : Disable 1 : Enable
30:29	/	/	/
28:25	R/W	0x0	MODQU Internal DAC Quantization Levels Levels= $[7*(21+MODQU[3:0])]/128$ Default levels= $7*21/128=1.15$
24:19	/	/	/
18	R/W	0x0	HPF_EN



			High Pass Filter Enable 0: Disable 1: Enable
17:12	R/W	0x0	DVOL Digital volume control: DVC, ATT=DVC[5:0]*(-1.16Db) 64 steps, -1.16Db/step
11:1	/	/	/
0	R/W	0x0	HUB_EN Audio Hub Enable 0: Disable 1: Enable

#### 4.21.5.2. 0x04 DAC FIFO Control Register(Default Value: 0x0000F00)

Offset: 0x04			Register Name: AC_DAC_FIFOC
Bit	R/W	Default/Hex	Description
31:29	R/W	0X0	DAC_FS Sample Rate Of DAC 000: 48KHz 010: 24KHz 100: 12KHz 110: 192KHz 001: 32KHz 011: 16KHz 101: 8KHz 111: 96KHz 44.1KHz/22.05KHz/11.025KHz can be supported by Audio PLL Configure Bit
28	R/W	0x0	FIR_VER FIR Version 0: 64-Tap FIR; 1: 32-Tap FIR
27	/	/	/
26	R/W	0x0	SEND_LASAT Audio sample select when TX FIFO under run 0: Sending zero 1: Sending last audio sample
25:24	R/W	0x0	FIFO_MODE For 24-bits transmitted audio sample: 00/10: FIFO_I[23:0] = {TXDATA[31:8]} 01/11: Reserved For 16-bits transmitted audio sample: 00/10: FIFO_I[23:0] = {TXDATA[31:16], 8'b0} 01/11: FIFO_I[23:0] = {TXDATA[15:0], 8'b0}
23	/	/	/
22:21	R/W	0X0	DAC_DRQ_CLR_CNT

			<p>When TX FIFO Available Room Less Than Or Equal N, DRQ Request Will Be De-Asserted. N Is Defined Here:</p> <p>00: IRQ/DRQ De-Asserted When WLEVEL &gt; TXTL</p> <p>01: 4</p> <p>10: 8</p> <p>11: 16</p>
20:15	/	/	/
14:8	R/W	0XF	<p>TX_TRIG_LEVEL</p> <p>TX FIFO Empty Trigger Level (TXTL[12:0])</p> <p>Interrupt and DMA request trigger level for TX FIFO normal condition.</p> <p>IRQ/DRQ Generated when WLEVEL ≤ TXTL</p> <p>Notes:</p> <ol style="list-style-type: none"> <li>1. WLEVEL represents the number of valid samples in the TX FIFO</li> <li>2. Only TXTL[6:0] valid when TXMODE = 0</li> </ol>
7	R/W	0X0	<p>ADDA_LOOP_EN</p> <p>ADDA Loop Enable</p> <p>0: Disable</p> <p>1: Enable</p>
6	R/W	0X0	<p>DAC_MONO_EN</p> <p>DAC Mono Enable</p> <p>0: Stereo, 64 Levels FIFO</p> <p>1: Mono, 128 Levels FIFO</p> <p>When Enabled, L &amp; R Channel Send Same Data</p>
5	R/W	0X0	<p>TX_SAMPLE_BITS</p> <p>Transmitting Audio Sample Resolution</p> <p>0: 16 bits</p> <p>1: 24 bits</p>
4	R/W	0X0	<p>DAC_DRQ_EN</p> <p>DAC FIFO Empty DRQ Enable</p> <p>0: Disable</p> <p>1: Enable</p>
3	R/W	0X0	<p>DAC_IRQ_EN</p> <p>DAC FIFO Empty IRQ Enable</p> <p>0: Disable</p> <p>1: Enable</p>
2	R/W	0X0	<p>FIFO_UNDERRUN_IRQ_EN</p> <p>DAC FIFO Under Run IRQ Enable</p> <p>0: Disable</p> <p>1: Enable</p>
1	R/W	0X0	<p>FIFO_OVERRUN_IRQ_EN</p> <p>DAC FIFO Over Run IRQ Enable</p> <p>0: Disable</p> <p>1: Enable</p>
0	R/W	0X0	<p>FIFO_FLUSH</p> <p>DAC FIFO Flush</p>

			Write '1' To Flush TX FIFO, Self Clear to '0'
--	--	--	---

#### 4.21.5.3. 0x08 DAC FIFO Status Register(Default Value: 0x00800088)

Offset: 0x08			Register Name: <b>AC_DAC_FIFOS</b>
Bit	R/W	Default/Hex	Description
31:24	/	/	/
23	R	0x1	TX_EMPTY TX FIFO Empty 0: No room for new sample in TX FIFO 1: More than one room for new sample in TX FIFO (>= 1 word)
22:8	R	0x80	TXE_CNT TX FIFO Empty Space Word Counter
7:4	/	/	/
3	R/W	0x1	TXE_INT TX FIFO Empty Pending Interrupt 0: No Pending IRQ 1: FIFO Empty Pending Interrupt Write '1' to clear this interrupt or automatic clear if interrupt condition fails
2	R/W	0x0	TXU_INT TX FIFO Under run Pending Interrupt 0: No Pending Interrupt 1: FIFO Under run Pending Interrupt Write '1' to clear this interrupt
1	R/W	0x0	TXO_INT TX FIFO Overrun Pending Interrupt 0: No Pending Interrupt 1: FIFO Overrun Pending Interrupt Write '1' to clear this interrupt
0	/	/	/

#### 4.21.5.4. 0x10 ADC FIFO Control Register(Default Value: 0x00000F00)

Offset: 0x10			Register Name: <b>AC_ADC_FIFOC</b>
Bit	R/W	Default/Hex	Description
31:29	R/W	0X0	ADFS Sample Rate of ADC 000: 48KHz 010: 24KHz 100: 12KHz 110: Reserved 001: 32KHz

			011: 16KHz 101: 8KHz 111: Reserved 44.1KHz/22.05KHz/11.025KHz can be supported by Audio PLL Configure Bit
28	R/W	0X0	EN_AD ADC Digital Part Enable 0: Disable 1: Enable
27:25	/	/	/
24	R/W	0X0	RX_FIFO_MODE RX FIFO Output Mode (Mode 0, 1) 0: Expanding '0' at LSB of TX FIFO register 1: Expanding received sample sign bit at MSB of TX FIFO register For 24-bits received audio sample: Mode 0: RXDATA[31:0] = {FIFO_O[23:0], 8'h0} Mode 1: Reserved For 16-bits received audio sample: Mode 0: RXDATA[31:0] = {FIFO_O[23:8], 16'h0} Mode 1: RXDATA[31:0] = {16{FIFO_O[23]}, FIFO_O[23:8]}
23:19	/	/	/
18:17	R/W	0X0	ADCFDT ADC FIFO Delay Time For writing Data after EN_AD 00:5ms 01:10ms 10:20ms 11:30ms
16	R/W	0X0	ADCDFEN ADC FIFO Delay Function For writing Data after EN_AD 0: Disable 1: Enable
15:13	/	/	/
12:8	R/W	0XF	RX_FIFO_TRG_LEVEL RX FIFO Trigger Level (RXTL[4:0]) Interrupt and DMA request trigger level for RX FIFO normal condition IRQ/DRQ Generated when WLEVEL < RXTL[4:0] Notes: WLEVEL represents the number of valid samples in the RX FIFO
7	R/W	0X0	ADC_MONO_EN ADC Mono Enable 0: Stereo, 16 levels FIFO 1: mono, 32 levels FIFO When set to '1', Only left channel samples are recorded
6	R/W	0x0	RX_SAMPLE_BITS Receiving Audio Sample Resolution 0: 16 bits

			1: 24 bits
5	/	/	/
4	R/W	0X0	ADC_DRQ_EN ADC FIFO Data Available DRQ Enable 0: Disable 1: Enable
3	R/W	0X0	ADC_IRQ_EN ADC FIFO Data Available IRQ Enable 0: Disable 1: Enable
2	/	/	
1	R/W	0X0	ADC_OVERRUN_IRQ_EN ADC FIFO Over Run IRQ Enable 0: Disable 1: Enable
0	R/W	0X0	ADC_FIFO_FLUSH ADC FIFO Flush Write '1' to flush TX FIFO, self clear to '0'

#### 4.21.5.5. 0x14 ADC FIFO Status Register(Default Value: 0x00000000)

Offset: 0x14			Register Name: AC_ADC_FIFOS
Bit	R/W	Default/Hex	Description
31:24	/	/	/
23	R	0X0	RXA RX FIFO Available 0: No available data in RX FIFO 1: More than one sample in RX FIFO (>= 1 word)
22:14	/	/	/
13:8	R	0X0	RXA_CNT RX FIFO Available Sample Word Counter
7:4	/	/	/
3	R/W	0X0	RXA_INT RX FIFO Data Available Pending Interrupt 0: No Pending IRQ 1: Data Available Pending IRQ Write '1' to clear this interrupt or automatic clear if interrupt condition fails
2	/	/	/
1	R/W	0X0	RXO_INT RX FIFO Overrun Pending Interrupt 0: No Pending IRQ 1: FIFO Overrun Pending IRQ Write '1' to clear this interrupt

0	/	/	/
---	---	---	---

**4.21.5.6. 0x18 ADC RX DATA Register(Default Value: 0x00000000)**

Offset: 0x18			Register Name: <b>AC_ADC_RXDATA</b>
Bit	R/W	Default/Hex	Description
31:0	R	0X0	RX_DATA RX Sample Host can get one sample by reading this register. The left channel sample data is first and then the right channel sample.

**4.21.5.7. 0x20 DAC TX DATA Register(Default Value: 0x00000000)**

Offset: 0x20			Register Name: <b>AC_DAC_TXDATA</b>
Bit	R/W	Default/Hex	Description
31:0	W	0X0	TX_DATA Transmitting left, right channel sample data should be written this register one by one. The left channel sample data is first and then the right channel sample

**4.21.5.8. 0x40 DAC TX Counter Register(Default Value: 0x00000000)**

Offset: 0x40			Register Name: <b>AC_DAC_CNT</b>
Bit	R/W	Default/Hex	Description
31:0	R/W	0X0	TX_CNT TX Sample Counter The audio sample number of sending into TXFIFO. When one sample is put into TXFIFO by DMA or by host IO, the TX sample counter register increases by one. The TX sample counter register can be set to any initial value at any time. After been updated by the initial value, the counter register should count on base of this initial value <b>Notes: It is used for Audio/ Video Synchronization</b>

**4.21.5.9. 0x44 ADC RX Counter Register(Default Value: 0x00000000)**

Offset: 0x44			Register Name: <b>AC_ADC_CNT</b>
Bit	R/W	Default/Hex	Description
31:0	R/W	0X0	RX_CNT RX Sample Counter

			<p>The audio sample number of writing into RXFIFO. When one sample is written by Digital Audio Engine, the RX sample counter register increases by one. The RX sample counter register can be set to any initial value at any time. After been updated by the initial value, the counter register should count on base of this initial value</p> <p><b>Notes: It is used for Audio/ Video Synchronization</b></p>
--	--	--	---

**4.21.5.10. 0x48 DAC Debug Register(Default Value: 0x00000000)**

Offset: 0x48			Register Name: <b>AC_DAC_DG</b>
Bit	R/W	Default/Hex	Description
31:12	/	/	/
11	R/W	0X0	DAC_MODU_SELECT DAC Modulator Debug 0: DAC Modulator Normal Mode 1: DAC Modulator Debug Mode
10:9	R/W	0X0	DAC_PATTERN_SELECT. DAC Pattern Select 00: Normal (Audio Sample from TX FIFO) 01: -6 dB Sin wave 10: -60 dB Sin wave 11: silent wave
8	R/W	0X0	CODEC_CLK_SELECT CODEC Clock Source Select 0: CODEC Clock from PLL 1: CODEC Clock from OSC (For Debug)
7	/	/	/
6	R/W	0X0	DA_SWP DAC output channel swap enable 0:Disable 1:Enable
5:0	/	/	/

**4.21.5.11. 0x4C ADC Debug Register(Default Value: 0x00000000)**

Offset: 0x4C			Register Name: <b>AC_ADC_DG</b>
Bit	R/W	Default/Hex	Description
31:25	/	/	/
24	R/W	0X0	AD_SWP ADC Output Channel Swap Enable (for digital filter) 0: Disable 1: Enable

23:0	/	/	/
------	---	---	---

**4.21.5.12. 0x60 DAC DAP Control Register(Default Value: 0x00000000)**

Offset: 0x60			Register Name: <b>AC_DAC_DAP_CTR</b>
Bit	R/W	Default/Hex	Description
31	R/W	0X0	DDAP_EN DAP for dac Enable 0 : bypass 1 : enable
30:16	/	/	/
15	R/W	0X0	DAC_DRC_EN DRC enable control 0:disable 1:enable
14	R/W	0X0	DAC_DRC_HPF_EN HPF enable control 0:disable 1:enable
13:0	/	/	/

**4.21.5.13. 0x70 ADC DAP Control Register(Default Value: 0x00000000)**

Offset: 0x70			Register Name: <b>AC_ADC_DAP_CTR</b>
Bit	R/W	Default/Hex	Description
31	R/W	0X0	ENAD_AGC AGC for ADC enable 0 : bypass      1: enable
30	R/W	0x0	ADAP_START. DAP for ADC start up 0 : disable 1: start up
29:27	/	/	/
26	R/W	0x0	ENADC_DRC DRC for ADC enable 0 : bypass   1 : enable
25	R/W	0x0	ADC_DRC_EN ADC DRC function enable
24	R/W	0x0	ADC_DRC_HPF_EN ADC DRC HPF function enable
23:22	/	/	/
21	R	0x0	ADAP_LSATU_FLAG.



			Left channel AGC saturation flag 0 : no saturation 1: saturation
20	R	0x0	ADAP_LNOI_FLAG. Left channel AGC noise-threshold flag 0: no noise-threshold 1: noise-threshold
19:12	R	0x0	ADAP_LCHAN_GAIN Left channel Gain applied by AGC (7.1format 2s component(-20dB - 40dB), 0.5dB/ step) 0x50 : 40dB 0x4F : 39.5dB ----- 0x00 : 00dB 0xFF : -0.5dB
11:10	/	/	/
9	R	0x0	ADAP_RSATU_FLAG. Right AGC saturation flag 0 : no saturation 1: saturation
8	R	0x0	ADAP_RNOI_FLAG. Right channel AGC noise-threshold flag 0: 1:
7:0	R	0x0	ADAP_LCHAN_GAIN. Right Channel Gain applied by AGC (7.1format 2s component)(0.5dB step ) 0x50 : 40dB 0x4F : 39.5dB ----- 0x00 : 00dB 0xFF : -0.5dB

**4.21.5.14. 0x74 ADC DAP Left Control Register(Default Value: 0x001F7000)**

Offset: 0x74			Register Name: <b>AC_ADC_DAP_LCTR</b>
Bit	R/W	Default/Hex	Description
31:24	/	/	/
23:16	R/W	0x1F (-86dB)	ADAP_LNOI_SET. Left channel noise threshold setting 0x00 : -24dB 0x01 : -26dB 0x02 : -28dB ----- 0x1D: -82dB

			0x1E: -84dB 0x1F: -86dB
15	/	/	/
14	R/W	0x1	AAGC_LCHAN_EN. Left AGC function enable 0:disable 1: enable
13	R/W	0x1	ADAP_LHPF_EN. Left HPF enable 0: disable 1: enable
12	R/W	0x1	ADAP_RNOI_DET. Left Noise detect enable 0: disable 1:enable
11:10	/	/	/
9:8	R/W	0x0	ADAP_LCHAN_HYS. Left Hysteresis setting 00 : 1dB 01 : 2dB 10 : 4dB 11 : disable
7:4	R/W	0x0	ADAP_LNOI_DEB. Left Noise debounce time 0000:0/fs 0001:4/fs 0010:8/fs ----- 1111 :16*4096/fs T=2(N+1)/fs ,except N=0
3:0	R/W	0x0	ADAP_LSIG_DEB. Left Signal debounce time 0000:0/fs 0001:4/fs 0010:8/fs ----- 1111 :16*4096/fs T=2(N+1)/fs ,except N=0

**4.21.5.15. 0x78 ADC DAP Right Control Register(Default Value: 0x001F7000)**

Offset: 0x78			Register Name: <b>AC_ADC_DAP_RCTR</b>
Bit	R/W	Default/Hex	Description
31:21	/	/	/

20:16	R/W	0x1F (-86dB)	ADAP_RNOI_SET. Right channel noise threshold setting 0x00 : -24dB 0x01 : -26dB 0x02 : -28dB ----- 0x1D: -82dB 0x1E: -84dB 0x1F: -86dB
15	/	/	/
14	R/W	0x1	AAGC_RCHAN_EN. Right AGC enable 0:disable 1:enable
13	R/W	0x1	ADAP_RHPF_EN. Right HPF enable 0: disable 1: enable
12	R/W	0x1	ADAP_RNOI_DET. Right Noise detect enable 0: disable 1:enable
11:10	/	/	/
9:8	R/W	0x0	ADAP_RCHAN_HYS. Right Hysteresis setting 00 : 1dB 01 : 2dB 10 : 4dB 11 : disable;
7:4	R/W	0x0	ADAP_RNOI_DEB. Right Noise debounce time 0000:0/fs 0001:4/fs 0010:8/fs ----- 1111: 16*4096/fs T=2(N+1)/fs ,except N=0
3:0	R/W	0x0	ADAP_RSIG_DEB. Right Signal debounce time 0000:0/fs 0001:4/fs 0010:8/fs ----- 1111: 16*4096/fs T=2(N+1)/fs ,except N=0

**4.21.5.16. 0x7C ADC DAP Parameter Register(Default Value: 0x2C2C2828)**

Offset: 0x7C			Register Name: AC_ADC_DAP_PARA
Bit	R/W	Default/Hex	Description
31:30	/	/	/
29:24	R/W	0x2C	ADAP_LTARG_SET. Left channel target level setting (-1dB -- -30dB). (6.0format 2s component)
23:22	/	/	/
21:16	R/W	0x2C	ADAP_RTARG_SET. Right channel target level setting (-1dB -- -30dB). (6.0format 2s component)
15:8	R/W	0x28	ADAP_LGAIN_MAX. Left channel max gain setting (0-40dB). (7.1format 2s component)
7:0	R/W	0x28	ADAP_RGAIN_MAX. Right channel max gain setting (0-40dB). (7.1format 2s component)

**4.21.5.17. 0x80 ADC DAP Left Average Coef Register(Default Value: 0x00051EB8)**

Offset: 0x80			Register Name: AC_ADC_DAP_LAC
Bit	R/W	Default/Hex	Description
31:27	/	/	/
26:0	R/W	0x0051EB8	ADAP_LAC. Average level coefficient setting(3.24format 2s component)

**4.21.5.18. 0x84 ADC DAP Left Decay & Attack Time Register(Default Value: 0x0000\_001F)**

Offset: 0x84			Register Name: AC_ADC_DAP_LDAT
Bit	R/W	Default/Hex	Description
31	/	/	/
30:16	R/W	0x0000	ADAP_LATT_SET Left attack time coefficient setting 0000 : 1x32/fs 0001 : 2x32/fs ----- 7FFF : 215 x32/fs $T=(n+1)*32*fs$ When the gain decreases, the actual gain will decrease 0.5dB at every attack time.
15	/	/	/
14:0	R/W	0x001F (32x32fs)	ADAP_LDEC_SET Left decay time coefficient setting

			0000 : 1x32/fs 0001 : 2x32/fs ----- 7FFF : 215 x32/fs $T=(n+1)*32/fs$ When the gain increases, the actual gain will increase 0.5dB at every decay time.
--	--	--	--

**4.21.5.19. 0x88 ADC DAP Right Average Coef Register(Default Value: 0x00051EB8)**

Offset: 0x88			Register Name: <b>AC_ADC_DAP_RAC</b>
Bit	R/W	Default/Hex	Description
31:27	/	/	/
26:0	R/W	0x00051EB8	ADAP_RAC. Average level coefficient setting(3,24format)

**4.21.5.20. 0x8C ADC DAP Right Decay & Attack Time Register(Default Value: 0x0000001F)**

Offset: 0x8C			Register Name: <b>AC_ADC_DAP_RDAT</b>
Bit	R/W	Default/Hex	Description
31	/	/	/
30:16	R/W	0x0000	ADAP_RATT_SET. Right attack time coefficient setting 0000 : 1x32/fs 0001 : 2x32/fs ----- 7FFF : 215 x32/fs $T=(n+1)*32/fs$ When the gain decreases, the actual gain will decrease 0.5dB at every attack time.
15	/	/	/
14:0	R/W	0x001F	ADAP_RDEC_SET Right decay time coefficient setting 0000 : 1x32/fs 0001 : 2x32/fs ----- 7FFF : 215x32/fs $T=(n+1)*32/fs$ When the gain increases, the actual gain will increase 0.5dB at every decay time.

**4.21.5.21. 0x90 ADC DAP HPF Coef Register(Default Value: 0x00FF\_FAC1)**

Offset: 0x90			Register Name: <b>AC_ADC_DAP_HPFC</b>
Bit	R/W	Default/Hex	Description
31:27	/	/	/
26:0	R/W	0x00FFAC1	ADAP_HPFC. HPF coefficient setting (3.24format)

**4.21.5.22. 0x94 ADC DAP Left Input Signal Low Average Coef Register(Default Value: 0x00051EB8)**

Offset: 0x94			Register Name: <b>AC_ADC_DAP_LINAC</b>
Bit	R/W	Default/Hex	Description
31:27	/	/	/
26:0	R/W	0x00051EB8	ADAP_LINAC Left input signal average filter coefficient to check noise or not (the coefficient is 3.24 format 2s complement) always the same as the left output signal average filter's

**4.21.5.23. 0x98 ADC DAP Right Input Signal Low Average Coef Register(Default Value: 0x00051EB8)**

Offset: 0x98			Register Name: <b>AC_ADC_DAP_RNAC</b>
Bit	R/W	Default/Hex	Description
31:27	/	/	/
26:0	R/W	0x00051EB8	ADAP_RINAC Right input signal average filter coefficient to check noise or not (the coefficient is 3.24 format 2s complement) always the same as the left output signal average filter's

**4.21.5.24. 0x9C ADC DAP Optimum Register(Default Value: 0x00000000)**

Offset: 0x9C			Register Name: <b>AC_ADC_DAP_OPT</b>
Bit	R/W	Default/Hex	Description
31:11	/	/	/
10	R/W	0	Left energy default value setting(include the input and output) 0 : min 1 : max
9 :8	R/W	00	Left channel gain hysteresis setting. The different between target level and the signal level must larger than the hysteresis when the gain change. 00 : 0.4375db

			01 : 0.9375db 10 : 1.9375db 11 : 3db
7:6	/	/	/
5	R/W	0	The input signal average filter coefficient setting 0 : is the reg94/reg98 1 : is the reg80/reg88;
4	R/W	0	AGC output when the channel in noise state 0 : output is zero 1 : output is the input data
3	/	/	/
2	R/W	0	Right energy default value setting(include the input and output) 0 : min 1 : max
1 : 0	R/W	00	Right channel gain hysteresis setting. The different between target level and the signal level must larger than the hysteresis when the gain change. 00 : 0.4375db 01 : 0.9375db 10 : 1.9375db 11 : 3db

**4.21.5.25. 0x100 DAC DRC High HPF Coef Register(Default Value: 0x000000FF)**

Offset: 0x100			Register Name: <b>AC_DAC_DRC_HHPFC</b>
Bit	R/W	Default/Hex	Description
15:11	/	/	/
10:0	R/W	0xff	HPF coefficient setting and the data is 3.24 format.

**4.21.5.26. 0x104 DAC DRC Low HPF Coef Register(Default Value: 0x0000FAC1)**

Offset: 0x104			Register Name: <b>AC_DAC_DRC_LHPFC</b>
Bit	R/W	Default/Hex	Description
15:0	R/W	0xFAC1	HPF coefficient setting and the data is 3.24 format.

**4.21.5.27. 0x108 DAC DRC Control Register(Default Value: 0x00000080)**

Offset: 0x108			Register Name: <b>AC_DAC_DRC_CTRL</b>
Bit	R/W	Default/Hex	Description
15	R	0	DRC delay buffer data output state when drc delay function is enable and the drc function disable. After disable drc function and this bit go to 0, the user

			should write the drc delay function bit to 0; 0 : not complete 1 : is complete
14:10	/	/	/
13:8	R/W	0	Signal delay time setting 6'h00 : (8x1)fs 6'h01 : (8x2)fs 6'h02 : (8x3)fs ----- 6'h2e : (8*47)fs 6'h2f : (8*48)fs 6'h30 -- 6'h3f : (8*48)fs Delay time = 8*(n+1)fs, n<6'h30; When the delay function is disable, the signal delay time is unused.
7	R/W	0x1	The delay buffer use or not when the drc disable and the drc buffer data output completely 0 : don't use the buffer 1 : use the buffer
6	R/W	0x0	DRC gain max limit enable 0 : disable 1 : enable
5	R/W	0x0	DRC gain min limit enable. when this function enable, it will overwrite the noise detect function. 0 : disable 1 : enable
4	R/W	0x0	Control the drc to detect noise when ET enable 0 : disable 1 : enable
3	R/W	0x0	Signal function Select 0 : RMS filter 1 : Peak filter When Signal function Select Peak filter, the RMS parameter is unused. (AC_DRC_LRMSHAT / AC_DRC_LRMSLAT / AC_DRC_LRMSHAT / AC_DRC_LRMSLAT) When Signal function Select RMS filter, the Peak filter parameter is unused.(AC_DRC_LPFHAT / AC_DRC_LPFLAT / AC_DRC_RPFHAT / AC_DRC_RPFLAT / AC_DRC_LPFHRT / AC_DRC_LPFLRT / AC_DRC_RPFHRT / AC_DRC_RPFLRT)
2	R/W	0x0	Delay function enable 0 : disable 1 : enable When the Delay function enable is disable, the Signal delay time is unused.
1	R/W	0x0	DRC LT enable 0 : disable 1 : enable



			When the DRC LT is disable the LT, KI and OPL parameter is unused.
0	R/W	0x0	DRC ET enable 0 : disable 1 : enable When the DRC ET is disable the ET, Ke and OPE parameter is unused.

**4.21.5.28. 0x10C DAC DRC Left Peak Filter High Attack Time Coef Register(Default Value: 0x0000\_000B)**

Offset: 0x10C			Register Name: <b>AC_DAC_DRC_LPFHAT</b>
Bit	R/W	Default/Hex	Description
15:11	/	/	/
10:0	R/W	0x000B	The left peak filter attack time parameter setting, which determine by the equation that $AT = 1 - \exp(-2.2T_s/ta)$ . The format is 3.24. (1ms)

**4.21.5.29. 0x110 DAC DRC Left Peak Filter Low Attack Time Coef Register(Default Value: 0x000077BF)**

Offset: 0x110			Register Name: <b>AC_DAC_DRC_LPFLAT</b>
Bit	R/W	Default/Hex	Description
15:0	R/W	0x77BF	The left peak filter attack time parameter setting, which determine by the equation that $AT = 1 - \exp(-2.2T_s/ta)$ . The format is 3.24. (1ms)

**4.21.5.30. 0x114 DAC DRC Right Peak Filter High Attack Time Coef Register(Default Value: 0x0000000B)**

Offset: 0x114			Register Name: <b>AC_DAC_DRC_RPFHAT</b>
Bit	R/W	Default/Hex	Description
15:11	/	/	/
10:0	R/W	0x000B	The left peak filter attack time parameter setting, which determine by the equation that $AT = 1 - \exp(-2.2T_s/ta)$ . The format is 3.24. (1ms)

**4.21.5.31. 0x118 DAC DRC Peak Filter Low Attack Time Coef Register(Default Value: 0x000077BF)**

Offset: 0x118			Register Name: <b>AC_DAC_DRC_RPFLAT</b>
Bit	R/W	Default/Hex	Description
15:0	R/W	0x77BF	The left peak filter attack time parameter setting, which determine by the equation that $AT = 1 - \exp(-2.2T_s/ta)$ . The format is 3.24. (1ms)

**4.21.5.32. 0x11C DAC DRC Left Peak Filter High Release Time Coef Register(Default Value: 0x000000FF)**

Offset: 0x11C			Register Name: <b>AC_DAC_DRC_LPFHRT</b>
Bit	R/W	Default/Hex	Description
15:11	/	/	/
10:0	R/W	0x00FF	The left peak filter release time parameter setting, which determine by the equation that $RT = \exp(-2.2Ts/tr)$ . The format is 3.24. (100ms)

**4.21.5.33. 0x120 DAC DRC Left Peak Filter Low Release Time Coef Register(Default Value: 0x0000E1F8)**

Offset: 0x120			Register Name: <b>AC_DAC_DRC_LPFLRT</b>
Bit	R/W	Default/Hex	Description
15:0	R/W	0xE1F8	The left peak filter release time parameter setting, which determine by the equation that $RT = \exp(-2.2Ts/tr)$ . The format is 3.24. (100ms)

**4.21.5.34. 0x124 DAC DRC Right Peak filter High Release Time Coef Register(Default Value: 0x0000\_00FF)**

Offset: 0x124			Register Name: <b>AC_DAC_DRC_RPFHRT</b>
Bit	R/W	Default/Hex	Description
15:11	/	/	/
10:0	R/W	0x00FF	The left peak filter attack time parameter setting, which determine by the equation that $RT = \exp(-2.2Ts/tr)$ . The format is 3.24. (100ms)

**4.21.5.35. 0x128 DAC DRC Right Peak filter Low Release Time Coef Register(Default Value: 0x0000E1F8)**

Offset: 0x128			Register Name: <b>AC_DAC_DRC_RPFLRT</b>
Bit	R/W	Default/Hex	Description
15:0	R/W	0xE1F8	The left peak filter release time parameter setting, which determine by the equation that $AT = \exp(-2.2Ts/tr)$ . The format is 3.24. (100ms)

**4.21.5.36. 0x12C DAC DRC Left RMS Filter High Coef Register(Default Value: 0x00000001)**

Offset: 0x12C			Register Name: <b>AC_DAC_DRC_LRMSHAT</b>
Bit	R/W	Default/Hex	Description
15:11	/	/	/
10:0	R/W	0x0001	The left RMS filter average time parameter setting, which determine by the equation that $AT = 1 - \exp(-2.2Ts/tav)$ . The format is 3.24. (10ms)

**4.21.5.37. 0x130 DAC DRC Left RMS Filter Low Coef Register(Default Value: 0x00002BAF)**

Offset: 0x130			Register Name: <b>AC_DAC_DRC_LRMSLAT</b>
Bit	R/W	Default/Hex	Description
15:0	R/W	0x2BAF	The left RMS filter average time parameter setting, which determine by the equation that $AT = 1 - \exp(-2.2T_s/t_{av})$ . The format is 3.24. (10ms)

**4.21.5.38. 0x134 DAC DRC Right RMS Filter High Coef Register(Default Value: 0x00000001)**

Offset: 0x134			Register Name: <b>AC_DAC_DRC_RRMSHAT</b>
Bit	R/W	Default/Hex	Description
15:11	/	/	/
10:0	R/W	0x0001	The right RMS filter average time parameter setting, which determine by the equation that $AT = 1 - \exp(-2.2T_s/t_{av})$ . The format is 3.24. (10ms)

**4.21.5.39. 0x138 DAC DRC Right RMS Filter Low Coef Register(Default Value: 0x00002BAF)**

Offset: 0x138			Register Name: <b>AC_DAC_DRC_RRMSLAT</b>
Bit	R/W	Default/Hex	Description
15:0	R/W	0x2BAF	The right RMS filter average time parameter setting, which determine by the equation that $AT = 1 - \exp(-2.2T_s/t_{av})$ . The format is 3.24. (10ms)

**4.21.5.40. 0x13C DAC DRC Compressor Threshold High Setting Register(Default Value: 0x000006A4)**

Offset: 0x13C			Register Name: <b>AC_DAC_DRC_HCT</b>
Bit	R/W	Default/Hex	Description
15:0	R/W	0x06A4	The compressor threshold setting, which set by the equation that $CT_{in} = -CT/6.0206$ . The format is 8.24 (-40dB)

**4.21.5.41. 0x140 DAC DRC Compressor Threshold High Setting Register(Default Value: 0x0000\_D3C0)**

Offset: 0x140			Register Name: <b>AC_DAC_DRC_LCT</b>
Bit	R/W	Default/Hex	Description
15:0	R/W	0xD3C0	The compressor threshold setting, which set by the equation that $CT_{in} = -CT/6.0206$ . The format is 8.24 (-40dB)

**4.21.5.42. 0x144 DAC DRC Compressor Slope High Setting Register(Default Value: 0x00000080)**

Offset: 0x144			Register Name: AC_DAC_DRC_HKC
Bit	R/W	Default/Hex	Description
15:13	/	/	/
13:0	R/W	0x0080	The slope of the compressor which determine by the equation that $K_c = 1/R$ , there, R is the ratio of the compressor, which always is interger. The format is 8.24. (2 : 1)

**4.21.5.43. 0x148 DAC DRC Compressor Slope Low Setting Register(Default Value: 0x0000\_0000)**

Offset: 0x148			Register Name: AC_DAC_DRC_LKC
Bit	R/W	Default/Hex	Description
15:0	R/W	0x0000	The slope of the compressor which determine by the equation that $K_c = 1/R$ , there, R is the ratio of the compressor, which always is interger. The format is 8.24. (2 : 1)

**4.21.5.44. 0x14C DAC DRC Compressor High Output at Compressor Threshold Register( Default Value: 0x0000F95B)**

Offset: 0x14C			Register Name: AC_DAC_DRC_HOPC
Bit	R/W	Default/Hex	Description
15:0	R/W	0xF95B	The output of the compressor which determine by the equation $-OPC/6.0206$ The format is 8.24 (-40dB)

**4.21.5.45. 0x150 DAC DRC Compressor Low Output at Compressor Threshold Register(Default Value: 0x00002C3F)**

Offset: 0x150			Register Name: AC_DAC_DRC_LOPC
Bit	R/W	Default/Hex	Description
15:0	R/W	0x2C3F	The output of the compressor which determine by the equation $OPC/6.0206$ The format is 8.24 (-40dB)

**4.21.5.46. 0x154 DAC DRC Limiter Theshold High Setting Register(Default Value: 0x000001A9)**

Offset: 0x154			Register Name: AC_DAC_DRC_HLT
Bit	R/W	Default/Hex	Description
15:0	R/W	0x01A9	The limiter threshold setting, which set by the equation that $LT_{in} = -LT/6.0206$ , The format is 8.24. (-10dB)

**4.21.5.47. 0x158 DAC DRC Limiter Theshold Low Setting Register(Default Value: 0x0000\_34F0)**

Offset: 0x158			Register Name: AC_DAC_DRC_LL
Bit	R/W	Default/Hex	Description
15:0	R/W	0x34F0	The limiter threshold setting, which set by the equation that $LT_{in} = -LT/6.0206$ , The format is 8.24. (-10dB)

**4.21.5.48. 0x15C DAC DRC Limiter Slope High Setting Register(Default Value: 0x0000\_0005)**

Offset: 0x15C			Register Name: AC_DAC_DRC_HK
Bit	R/W	Default/Hex	Description
15:11	/	/	/
13:0	R/W	0x0005	The slope of the limiter which determine by the equation that $KI = 1/R$ , there, R is the ratio of the limiter, which always is interger. The format is 8.24. (50 :1)

**4.21.5.49. 0x160 DAC DRC Limiter Slope Low Setting Register(Default Value: 0x00001EB8)**

Offset: 0x160			Register Name: AC_DAC_DRC_LK
Bit	R/W	Default/Hex	Description
15:0	R/W	0x1EB8	The slope of the limiter which determine by the equation that $KI = 1/R$ , there, R is the ratio of the limiter, which always is interger. The format is 8.24. (50 :1)

**4.21.5.50. 0x164 DAC DRC Limiter High Output at Limiter Threshold(Default Value: 0x0000FBD8)**

Offset: 0x164			Register Name: AC_DAC_DRC_HOPL
Bit	R/W	Default/Hex	Description
15:0	R/W	0xFBD8	The output of the limiter which determine by equation $OPT/6.0206$ . The format is 8.24 (-25dB)

**4.21.5.51. 0x168 DAC DRC Limiter Low Output at Limiter Threshold(Default Value: 0x0000FBA7)**

Offset: 0x168			Register Name: AC_DAC_DRC_LOPL
Bit	R/W	Default/Hex	Description
15:0	R/W	0xFBA7	The output of the limiter which determine by equation $OPT/6.0206$ . The format is 8.24 (-25dB)

**4.21.5.52. 0x16C DAC DRC Expander Theshold High Setting Register(Default Value: 0x0000BA0)**

Offset: 0x16C			Register Name: <b>AC_DAC_DRC_HET</b>
Bit	R/W	Default/Hex	Description
15:0	R/W	0x0BA0	The expander threshold setting, which set by the equation that $ET_{in} = -ET/6.0206$ , The format is 8.24. (-70dB)

**4.21.5.53. 0x170 DAC DRC Expander Theshold Low Setting Register(Default Value: 0x00007291)**

Offset: 0x170			Register Name: <b>AC_DAC_DRC_LET</b>
Bit	R/W	Default/Hex	Description
15:0	R/W	0x7291	The expander threshold setting, which set by the equation that $ET_{in} = -ET/6.0206$ , The format is 8.24. (-70dB)

**4.21.5.54. 0x174 DAC DRC Expander Slope High Setting Register(Default Value: 0x00000500)**

Offset: 0x174			Register Name: <b>AC_DAC_DRC_HKE</b>
Bit	R/W	Default/Hex	Description
15:14	/	/	/
13:0	R/W	0x0500	The slope of the expander which determine by the equation that $Ke = 1/R$ , there, R is the ratio of the expander, which always is interger and the ke must larger than 50. The format is 8.24. (1:5)

**4.21.5.55. 0x178 DAC DRC Expander Slope Low Setting Register(Default Value: 0x00000000)**

Offset: 0x178			Register Name: <b>AC_DAC_DRC_LKE</b>
Bit	R/W	Default/Hex	Description
15:0	R/W	0x0000	The slope of the expander which determine by the equation that $Ke = 1/R$ , there, R is the ratio of the expander, which always is interger and the ke must larger than 50. The format is 8.24. (1:5)

**4.21.5.56. 0x17C DAC DRC Expander High Output at Expander Threshold(Default Value: 0x0000F45F)**

Offset: 0x17C			Register Name: <b>AC_DAC_DRC_HOPE</b>
Bit	R/W	Default/Hex	Description
15:0	R/W	0xF45F	The output of the expander which determine by equation $OPE/6.0206$ . The format is 8.24 (-70dB)

**4.21.5.57. 0x180 DAC DRC Expander Low Output at Expander Threshold(Default Value: 0x00008D6E)**

Offset: 0x180			Register Name: <b>AC_DAC_DRC_LOPE</b>
Bit	R/W	Default/Hex	Description
15:0	R/W	0x8D6E	The output of the expander which determine by equation $OPE/6.0206$ . The format is 8.24 (-70dB)

**4.21.5.58. 0x184 DAC DRC Linear Slope High Setting Register(Default Value: 0x00000100)**

Offset: 0x184			Register Name: <b>AC_DAC_DRC_HKN</b>
Bit	R/W	Default/Hex	Description
15:14	/	/	/
13:0	R/W	0x0100	The slope of the linear which determine by the equation that $K_n = 1/R$ , there, R is the ratio of the linear, which always is interger . The format is 8.24. (1:1)

**4.21.5.59. 0x188 DAC DRC Linear Slope Low Setting Register(Default Value: 0x00000000)**

Offset: 0x188			Register Name: <b>AC_DAC_DRC_LKN</b>
Bit	R/W	Default/Hex	Description
15:0	R/W	0x0000	The slope of the linear which determine by the equation that $K_n = 1/R$ , there, R is the ratio of the linear, which always is interger . The format is 8.24. (1:1)

**4.21.5.60. 0x18C DAC DRC Smooth filter Gain High Attack Time Coef Register(Default Value: 0x00000002)**

Offset: 0x18C			Register Name: <b>AC_DAC_DRC_SFHAT</b>
Bit	R/W	Default/Hex	Description
15:11	/	/	/
10:0	R/W	0x0002	The smooth filter attack time parameter setting, which determine by the equation that $AT = 1 - \exp(-2.2T_s/tr)$ . The format is 3.24. (5ms)

**4.21.5.61. 0x190 DAC DRC Smooth filter Gain Low Attack Time Coef Register(Default Value: 0x00005600)**

Offset: 0x190			Register Name: <b>AC_DAC_DRC_SFLAT</b>
Bit	R/W	Default/Hex	Description
15:0	R/W	0x5600	The smooth filter attack time parameter setting, which determine by the equation that $AT = 1 - \exp(-2.2T_s/tr)$ . The format is 3.24. (5ms)

**4.21.5.62. 0x194 DAC DRC Smooth filter Gain High Release Time Coef Register(Default Value: 0x00000000)**

Offset: 0x194			Register Name: <b>AC_DAC_DRC_SFHRT</b>
Bit	R/W	Default/Hex	Description
15:11	/	/	/
10:0	R/W	0x0000	The gain smooth filter release time parameter setting, which determine by the equation that $RT = 1 - \exp(-2.2T_s/tr)$ . The format is 3.24. (200ms)

**4.21.5.63. 0x198 DAC DRC Smooth filter Gain Low Release Time Coef Register(Default Value: 0x00000F04)**

Offset: 0x198			Register Name: <b>AC_DAC_DRC_SFLRT</b>
Bit	R/W	Default/Hex	Description
15:0	R/W	0x0F04	The gain smooth filter release time parameter setting, which determine by the equation that $RT = 1 - \exp(-2.2T_s/tr)$ . The format is 3.24. (200ms)

**4.21.5.64. 0x19C DAC DRC MAX Gain High Setting Register(Default Value: 0x0000FE56)**

Offset: 0x19C			Register Name: <b>AC_DAC_DRC_MXGHS</b>
Bit	R/W	Default/Hex	Description
15:0	R/W	0xFE56	The max gain setting which determine by equation $MXG/6.0206$ . The format is 8.24 and must $-20dB < MXG < 30dB$ (-10dB)

**4.21.5.65. 0x1A0 DAC DRC MAX Gain Low Setting Register(Default Value: 0x0000CB0F)**

Offset: 0x1A0			Register Name: <b>AC_DAC_DRC_MXGLS</b>
Bit	R/W	Default/Hex	Description
15:0	R/W	0xCB0F	The max gain setting which determine by equation $MXG/6.0206$ . The format is 8.24 and must $-20dB < MXG < 30dB$ (-10dB)

**4.21.5.66. 0x1A4 DAC DRC MIN Gain High Setting Register(Default Value: 0x0000F95B)**

Offset: 0x1A4			Register Name: <b>AC_DAC_DRC_MNGHS</b>
Bit	R/W	Default/Hex	Description
15:0	R/W	0xF95B	The min gain setting which determine by equation $MXG/6.0206$ . The format is 8.24 and must $-60dB \leq MNG \leq -30dB$ (-40dB)



**4.21.5.67. 0x1A8 DAC DRC MIN Gain Low Setting Register(Default Value: 0x00002C3F)**

Offset: 0x1A8			Register Name: <b>AC_DAC_DRC_MNGLS</b>
Bit	R/W	Default/Hex	Description
15:0	R/W	0x2C3F	The min gain setting which determine by equation $MNG/6.0206$ . The format is 8.24 and must $-60dB \leq MNG \leq -30dB$ (-40dB)

**4.21.5.68. 0x1AC DAC DRC Expander Smooth Time High Coef Register(Default Value: 0x00000000)**

Offset: 0x1AC			Register Name: <b>AC_DAC_DRC_EPSHC</b>
Bit	R/W	Default/Hex	Description
11:0	R/W	0x0000	The gain smooth filter release and attack time parameter setting in expander region, which determine by the equation that $RT = 1 - \exp(-2.2Ts/tr)$ . The format is 3.24. (30ms)

**4.21.5.69. 0x1B0 DAC DRC Expander Smooth Time Low Coef Register(Default Value: 0x0000640C)**

Offset: 0x1B0			Register Name: <b>AC_DAC_DRC_EPSLC</b>
Bit	R/W	Default/Hex	Description
15:0	R/W	0x640C	The gain smooth filter release and attack time parameter setting in expander region, which determine by the equation that $RT = 1 - \exp(-2.2Ts/tr)$ . The format is 3.24. (30ms)

**4.21.5.70. 0x1B8 DAC DRC HPF Gain High Coef Register(Default Value: 0x00000100)**

Offset: 0x1B8			Register Name: <b>AC_DAC_DRC_HPFHGAIN</b>
Bit	R/W	Default/Hex	Description
15:11	/	/	/
10:0	R/W	0x0100	The gain of the hpf coefficient setting which format is 3.24.(gain = 1)

**4.21.5.71. 0x1BC DAC DRC HPF Gain Low Coef Register(Default Value: 0x00000000)**

Offset: 0x1BC			Register Name: <b>AC_DAC_DRC_HPFLGAIN</b>
Bit	R/W	Default/Hex	Description
15:0	R/W	0x0000	The gain of the hpf coefficient setting which format is 3.24.(gain = 1)

**4.21.5.72. 0x200 ADC DRC High HPF Coef Register(Default Value: 0x000000FF)**

Offset: 0x200			Register Name: <b>AC_ADC_DRC_HHPFC</b>
Bit	R/W	Default/Hex	Description
15:11	/	/	/
10:0	R/W	0xFF	HPF coefficient setting and the data is 3.24 format.

**4.21.5.73. 0x204 ADC DRC Low HPF Coef Register(Default Value: 0x0000FAC1)**

Offset: 0x204			Register Name: <b>AC_ADC_DRC_LHPFC</b>
Bit	R/W	Default/Hex	Description
15:0	R/W	0xFAC1	HPF coefficient setting and the data is 3.24 format.

**4.21.5.74. 0x208 ADC DRC Control Register(Default Value: 0x00000080)**

Offset: 0x208			Register Name: <b>AC_ADC_DRC_CTRL</b>
Bit	R/W	Default/Hex	Description
15	R	0	DRC delay buffer data output state when drc delay function is enable and the drc function disable. After disable drc function and this bit go to 0, the user should write the drc delay function bit to 0; 0 : not complete 1 : is complete
14:10	/	/	/
13:8	R/W	0	Signal delay time setting 6'h00 : (8x1)fs 6'h01 : (8x2)fs 6'h02 : (8x3)fs ----- 6'h2e : (8*47)fs 6'h2f : (8*48)fs 6'h30 -- 6'h3f : (8*48)fs Delay time = 8*(n+1)fs, n<6'h30; When the delay function is disable, the signal delay time is unused.
7	R/W	0x1	The delay buffer use or not when the drc disable and the drc buffer data output completely 0 : don't use the buffer 1 : use the buffer
6	R/W	0x0	DRC gain max limit enable 0 : disable 1 : enable
5	R/W	0x0	DRC gain min limit enable. when this function enable, it will overwrite the noise detect function.

			0 : disable 1 : enable
4	R/W	0x0	Control the drc to detect noise when ET enable 0 : disable 1 : enable
3	R/W	0x0	Signal function Select 0 : RMS filter 1 : Peak filter When Signal function Select Peak filter, the RMS parameter is unused. (AC_DRC_LRMSHAT / AC_DRC_LRMSLAT / AC_DRC_LRMSHAT / AC_DRC_LRMSLAT) When Signal function Select RMS filter, the Peak filter parameter is unused. (AC_DRC_LPFHAT / AC_DRC_LPFLAT / AC_DRC_RPFHAT / AC_DRC_RPFLAT / AC_DRC_LPFHRT / AC_DRC_LPFLRT / AC_DRC_RPFHRT / AC_DRC_RPFLRT)
2	R/W	0x0	Delay function enable 0 : disable 1 : enable When the Delay function enable is disable, the Signal delay time is unused.
1	R/W	0x0	DRC LT enable 0 : disable 1 : enable When the DRC LT is disable the LT, KI and OPL parameter is unused.
0	R/W	0x0	DRC ET enable 0 : disable 1 : enable When the DRC ET is disable the ET, Ke and OPE parameter is unused.

#### 4.21.5.75. 0x20C ADC DRC Left Peak Filter High Attack Time Coef Register(Default Value: 0x0000000B)

Offset: 0x20C			Register Name: <b>AC_ADC_DRC_LPFHAT</b>
Bit	R/W	Default/Hex	Description
15:11	/	/	/
10:0	R/W	0x000B	The left peak filter attack time parameter setting, which determine by the equation that $AT = 1 - \exp(-2.2Ts/ta)$ . The format is 3.24. (1ms)

#### 4.21.5.76. 0x210 ADC DRC Left Peak Filter Low Attack Time Coef Register(Default Value: 0x0000\_77BF)

Offset: 0x210			Register Name: <b>AC_ADC_DRC_LPFLAT</b>
Bit	R/W	Default/Hex	Description
15:0	R/W	0x77BF	The left peak filter attack time parameter setting, which determine by the equation that $AT = 1 - \exp(-2.2Ts/ta)$ . The format is 3.24. (1ms)

**4.21.5.77. 0x214 ADC DRC Right Peak Filter High Attack Time Coef Register(Default Value: 0x0000\_000B)**

Offset: 0x214			Register Name: <b>AC_ADC_DRC_RPFHAT</b>
Bit	R/W	Default/Hex	Description
15:11	/	/	/
10:0	R/W	0x000B	The left peak filter attack time parameter setting, which determine by the equation that $AT = 1 - \exp(-2.2T_s/ta)$ . The format is 3.24. (1ms)

**4.21.5.78. 0x218 ADC DRC Peak Filter Low Attack Time Coef Register(Default Value: 0x000077BF)**

Offset: 0x218			Register Name: <b>AC_ADC_DRC_RPFLAT</b>
Bit	R/W	Default/Hex	Description
15:0	R/W	0x77BF	The left peak filter attack time parameter setting, which determine by the equation that $AT = 1 - \exp(-2.2T_s/ta)$ . The format is 3.24. (1ms)

**4.21.5.79. 0x21C ADC DRC Left Peak Filter High Release Time Coef Register(Default Value: 0x000000FF)**

Offset: 0x21C			Register Name: <b>AC_ADC_DRC_LPFHRT</b>
Bit	R/W	Default/Hex	Description
15:11	/	/	/
10:0	R/W	0x00FF	The left peak filter release time parameter setting, which determine by the equation that $RT = \exp(-2.2T_s/tr)$ . The format is 3.24. (100ms)

**4.21.5.80. 0x220 ADC DRC Left Peak Filter Low Release Time Coef Register(Default Value: 0x0000E1F8)**

Offset: 0x220			Register Name: <b>AC_ADC_DRC_LPFLRT</b>
Bit	R/W	Default/Hex	Description
15:0	R/W	0xE1F8	The left peak filter release time parameter setting, which determine by the equation that $RT = \exp(-2.2T_s/tr)$ . The format is 3.24. (100ms)

**4.21.5.81. 0x224 ADC DRC Right Peak filter High Release Time Coef Register(Default Value: 0x000000FF)**

Offset: 0x224			Register Name: <b>AC_ADC_DRC_RPFHRT</b>
Bit	R/W	Default/Hex	Description
15:11	/	/	/
10:0	R/W	0x00FF	The left peak filter attack time parameter setting, which determine by the equation that $RT = \exp(-2.2T_s/tr)$ . The format is 3.24. (100ms)

**4.21.5.82. 0x228 ADC DRC Right Peak filter Low Release Time Coef Register(Default Value: 0x0000E1F8)**

Offset: 0x228			Register Name: <b>AC_ADC_DRC_RPFLRT</b>
Bit	R/W	Default/Hex	Description
15:0	R/W	0xE1F8	The left peak filter release time parameter setting, which determine by the equation that $AT = \exp(-2.2Ts/tr)$ . The format is 3.24. (100ms)

**4.21.5.83. 0x22C ADC DRC Left RMS Filter High Coef Register(Default Value: 0x00000001)**

Offset: 0x22C			Register Name: <b>AC_ADC_DRC_LRMSHAT</b>
Bit	R/W	Default/Hex	Description
15:11	/	/	/
10:0	R/W	0x0001	The left RMS filter average time parameter setting, which determine by the equation that $AT = 1 - \exp(-2.2Ts/tav)$ . The format is 3.24. (10ms)

**4.21.5.84. 0x230 ADC DRC Left RMS Filter Low Coef Register(Default Value: 0x00002BAF)**

Offset: 0x230			Register Name: <b>AC_ADC_DRC_LRMSLAT</b>
Bit	R/W	Default/Hex	Description
15:0	R/W	0x2BAF	The left RMS filter average time parameter setting, which determine by the equation that $AT = 1 - \exp(-2.2Ts/tav)$ . The format is 3.24. (10ms)

**4.21.5.85. 0x234 ADC DRC Right RMS Filter High Coef Register(Default Value: 0x00000001)**

Offset: 0x234			Register Name: <b>AC_ADC_DRC_RRMSHAT</b>
Bit	R/W	Default/Hex	Description
15:11	/	/	/
10:0	R/W	0x0001	The right RMS filter average time parameter setting, which determine by the equation that $AT = 1 - \exp(-2.2Ts/tav)$ . The format is 3.24. (10ms)

**4.21.5.86. 0x238 ADC DRC Right RMS Filter Low Coef Register(Default Value: 0x00002BAF)**

Offset: 0x238			Register Name: <b>AC_ADC_DRC_RRMSLAT</b>
Bit	R/W	Default/Hex	Description
15:0	R/W	0x2BAF	The right RMS filter average time parameter setting, which determine by the equation that $AT = 1 - \exp(-2.2Ts/tav)$ . The format is 3.24. (10ms)

**4.21.5.87. 0x23C ADC DRC Compressor Theshold High Setting Register(Default Value: 0x00006A4)**

Offset: 0x23C			Register Name: <b>AC_ADC_DRC_HCT</b>
Bit	R/W	Default/Hex	Description
15:0	R/W	0x06A4	The compressor threshold setting, which set by the equation that $CT_{in} = -CT/6.0206$ . The format is 8.24 (-40dB)

**4.21.5.88. 0x240 ADC DRC Compressor Slope High Setting Register(Default Value: 0x0000D3C0)**

Offset: 0x240			Register Name: <b>AC_ADC_DRC_LCT</b>
Bit	R/W	Default/Hex	Description
15:0	R/W	0xD3C0	The compressor threshold setting, which set by the equation that $CT_{in} = -CT/6.0206$ . The format is 8.24 (-40dB)

**4.21.5.89. 0x244 ADC DRC Compressor Slope High Setting Register(Default Value: 0x00000080)**

Offset: 0x244			Register Name: <b>AC_ADC_DRC_HKC</b>
Bit	R/W	Default/Hex	Description
15:13	/	/	/
13:0	R/W	0x0080	The slope of the compressor which determine by the equation that $K_c = 1/R$ , there, R is the ratio of the compressor, which always is interger. The format is 8.24. (2 : 1)

**4.21.5.90. 0x248 ADC DRC Compressor Slope Low Setting Register(Default Value: 0x00000000)**

Offset: 0x248			Register Name: <b>AC_ADC_DRC_LKC</b>
Bit	R/W	Default/Hex	Description
15:0	R/W	0x0000	The slope of the compressor which determine by the equation that $K_c = 1/R$ , there, R is the ratio of the compressor, which always is interger. The format is 8.24. (2 : 1)

**4.21.5.91. 0x24C ADC DRC Compressor High Output at Compressor Threshold Register(Default Value: 0x0000F95B)**

Offset: 0x24C			Register Name: <b>AC_ADC_DRC_HOPC</b>
Bit	R/W	Default/Hex	Description
15:0	R/W	0xF95B	The output of the compressor which determine by the equation $OPC/6.0206$ The format is 8.24 (-40dB)

**4.21.5.92. 0x250 ADC DRC Compressor Low Output at Compressor Threshold Register(Default Value: 0x00002C3F)**

Offset: 0x250			Register Name: <b>AC_ADC_DRC_LOPC</b>
Bit	R/W	Default/Hex	Description
15:0	R/W	0x2C3F	The output of the compressor which determine by the equation $OPC/6.0206$ The format is 8.24 (-40dB)

**4.21.5.93. 0x254 ADC DRC Limiter Theshold High Setting Register(Default Value: 0x000001A9)**

Offset: 0x254			Register Name: <b>AC_ADC_DRC_HLT</b>
Bit	R/W	Default/Hex	Description
15:0	R/W	0x01A9	The limiter threshold setting, which set by the equation that $LTin = -LT/6.0206$ , The format is 8.24. (-10dB)

**4.21.5.94. 0x258 ADC DRC Limiter Theshold Low Setting Register(Default Value: 0x000034F0)**

Offset: 0x258			Register Name: <b>AC_ADC_DRC_LLT</b>
Bit	R/W	Default/Hex	Description
15:0	R/W	0x34F0	The limiter threshold setting, which set by the equation that $LTin = -LT/6.0206$ , The format is 8.24. (-10dB)

**4.21.5.95. 0x25C ADC DRC Limiter Slope High Setting Register(Default Value: 0x00000005)**

Offset: 0x25C			Register Name: <b>AC_ADC_DRC_HKI</b>
Bit	R/W	Default/Hex	Description
15:11	/	/	/
13:0	R/W	0x0005	The slope of the limiter which determine by the equation that $KI = 1/R$ , there, R is the ratio of the limiter, which always is interger. The format is 8.24. (50 :1)

**4.21.5.96. 0x260 ADC DRC Limiter Slope Low Setting Register(Default Value: 0x1EB8)**

Offset: 0x260			Register Name: <b>AC_ADC_DRC_LKI</b>
Bit	R/W	Default/Hex	Description
15:0	R/W	0x1EB8	The slope of the limiter which determine by the equation that $KI = 1/R$ , there, R is the ratio of the limiter, which always is interger. The format is 8.24. (50 :1)

**4.21.5.97. 0x264 ADC DRC Limiter High Output at Limiter Threshold(Default Value: 0x0000FBD8)**

Offset: 0x264			Register Name: <b>AC_ADC_DRC_HOPL</b>
Bit	R/W	Default/Hex	Description
15:0	R/W	0xFBD8	The output of the limiter which determine by equation OPT/6.0206. The format is 8.24 (-25dB)

**4.21.5.98. 0x268 ADC DRC Limiter Low Output at Limiter Threshold(Default Value: 0x0000FBA7)**

Offset: 0x268			Register Name: <b>AC_ADC_DRC_LOPL</b>
Bit	R/W	Default/Hex	Description
15:0	R/W	0xFBA7	The output of the limiter which determine by equation OPT/6.0206. The format is 8.24 (-25dB)

**4.21.5.99. 0x26C ADC DRC Expander Theshold High Setting Register(Default Value: 0x00000BA0)**

Offset: 0x26C			Register Name: <b>AC_ADC_DRC_HET</b>
Bit	R/W	Default/Hex	Description
15:0	R/W	0x0BA0	The expander threshold setting, which set by the equation that $ET_{in} = -ET/6.0206$ , The format is 8.24. (-70dB)

**4.21.5.100. 0x270 ADC DRC Expander Theshold Low Setting Register(Default Value: 0x00007291)**

Offset: 0x270			Register Name: <b>AC_ADC_DRC_LET</b>
Bit	R/W	Default/Hex	Description
15:0	R/W	0x7291	The expander threshold setting, which set by the equation that $ET_{in} = -ET/6.0206$ , The format is 8.24. (-70dB)

**4.21.5.101. 0x274 ADC DRC Expander Slope High Setting Register(Default Value: 0x00000500)**

Offset: 0x274			Register Name: <b>AC_ADC_DRC_HKE</b>
Bit	R/W	Default/Hex	Description
15:14	/	/	/
13:0	R/W	0x0500	The slope of the expander which determine by the equation that $Ke = 1/R$ , there, R is the ratio of the expander, which always is interger and the ke must larger than 50. The format is 8.24. (1:5)



**4.21.5.102. 0x278 ADC DRC Expander Slope Low Setting Register(Default Value: 0x00000000)**

Offset: 0x278			Register Name: <b>AC_ADC_DRC_LKE</b>
Bit	R/W	Default/Hex	Description
15:0	R/W	0x0000	The slope of the expander which determine by the equation that $K_e = 1/R$ , there, R is the ratio of the expander, which always is interger and the ke must larger than 50. The format is 8.24. (1:5)

**4.21.5.103. 0x27C ADC DRC Expander High Output at Expander Threshold(Default Value: 0x0000F45F)**

Offset: 0x27C			Register Name: <b>AC_ADC_DRC_HOPE</b>
Bit	R/W	Default/Hex	Description
15:0	R/W	0xF45F	The output of the expander which determine by equation OPE/6.0206. The format is 8.24 (-70dB)

**4.21.5.104. 0x280 ADC DRC Expander Low Output at Expander Threshold(Default Value: 0x00008D6E)**

Offset: 0x280			Register Name: <b>AC_ADC_DRC_LOPE</b>
Bit	R/W	Default/Hex	Description
15:0	R/W	0x8D6E	The output of the expander which determine by equation OPE/6.0206. The format is 8.24 (-70dB)

**4.21.5.105. 0x284 ADC DRC Linear Slope High Setting Register(Default Value: 0x00000100)**

Offset: 0x284			Register Name: <b>AC_ADC_DRC_HKN</b>
Bit	R/W	Default/Hex	Description
15:14	/	/	/
13:0	R/W	0x0100	The slope of the linear which determine by the equation that $K_n = 1/R$ , there, R is the ratio of the linear, which always is interger . The format is 8.24. (1:1)

**4.21.5.106. 0x288 ADC DRC Linear Slope Low Setting Register(Default Value: 0x00000000)**

Offset: 0x288			Register Name: <b>AC_ADC_DRC_LKN</b>
Bit	R/W	Default/Hex	Description
15:0	R/W	0x0000	The slope of the linear which determine by the equation that $K_n = 1/R$ , there, R is the ratio of the linear, which always is interger . The format is 8.24. (1:1)

**4.21.5.107. 0x28C ADC DRC Smooth filter Gain High Attack Time Coef Register(Default Value: 0x00000002)**

Offset: 0x28C			Register Name: <b>AC_ADC_DRC_SFHAT</b>
Bit	R/W	Default/Hex	Description
15:11	/	/	/
10:0	R/W	0x0002	The smooth filter attack time parameter setting, which determine by the equation that $AT = 1 - \exp(-2.2Ts/tr)$ . The format is 3.24. (5ms)

**4.21.5.108. 0x290 ADC DRC Smooth filter Gain Low Attack Time Coef Register(Default Value: 0x00005600)**

Offset: 0x290			Register Name: <b>AC_ADC_DRC_SFLAT</b>
Bit	R/W	Default/Hex	Description
15:0	R/W	0x5600	The smooth filter attack time parameter setting, which determine by the equation that $AT = 1 - \exp(-2.2Ts/tr)$ . The format is 3.24. (5ms)

**4.21.5.109. 0x294 ADC DRC Smooth filter Gain High Release Time Coef Register(Default Value: 0x00000000)**

Offset: 0x294			Register Name: <b>AC_ADC_DRC_SFHRT</b>
Bit	R/W	Default/Hex	Description
15:11	/	/	/
10:0	R/W	0x0000	The gain smooth filter release time parameter setting, which determine by the equation that $RT = 1 - \exp(-2.2Ts/tr)$ . The format is 3.24. (200ms)

**4.21.5.110. 0x298 ADC DRC Smooth filter Gain Low Release Time Coef Register(Default Value: 0x00000F04)**

Offset: 0x298			Register Name: <b>AC_ADC_DRC_SFLRT</b>
Bit	R/W	Default/Hex	Description
15:0	R/W	0x0F04	The gain smooth filter release time parameter setting, which determine by the equation that $RT = 1 - \exp(-2.2Ts/tr)$ . The format is 3.24. (200ms)

**4.21.5.111. 0x29C ADC DRC MAX Gain High Setting Register(Default Value: 0x0000FE56)**

Offset: 0x29C			Register Name: <b>AC_ADC_DRC_MXGHS</b>
Bit	R/W	Default/Hex	Description
15:0	R/W	0xFE56	The max gain setting which determine by equation $MXG/6.0206$ . The format is 8.24 and must $-20dB < MXG < 30dB$ (-10dB)

**4.21.5.112. 0x2A0 ADC DRC MAX Gain Low Setting Register(Default Value: 0x0000CB0F)**

Offset: 0x2A0			Register Name: <b>AC_ADC_DRC_MXGLS</b>
Bit	R/W	Default/Hex	Description
15:0	R/W	0xCB0F	The max gain setting which determine by equation $MXG/6.0206$ . The format is 8.24 and must $-20dB < MXG < 30dB$ (-10dB)

**4.21.5.113. 0x2A4 ADC DRC MIN Gain High Setting Register(Default Value: 0x0000F95B)**

Offset: 0x2A4			Register Name: <b>AC_ADC_DRC_MNGHS</b>
Bit	R/W	Default/Hex	Description
15:0	R/W	0xF95B	The min gain setting which determine by equation $MXG/6.0206$ . The format is 8.24 and must $-60dB \leq MNG \leq -30dB$ (-40dB)

**4.21.5.114. 0x2A8 ADC DRC MIN Gain Low Setting Register(Default Value: 0x00002C3F)**

Offset: 0x2A8			Register Name: <b>AC_ADC_DRC_MNGLS</b>
Bit	R/W	Default/Hex	Description
15:0	R/W	0x2C3F	The min gain setting which determine by equation $MNG/6.0206$ . The format is 8.24 and must $-60dB \leq MNG \leq -30dB$ (-40dB)

**4.21.5.115. 0x2AC ADC DRC Expander Smooth Time High Coef Register(Default Value: 0x00000000)**

Offset: 0x2AC			Register Name: <b>AC_ADC_DRC_EPSHC</b>
Bit	R/W	Default/Hex	Description
10:0	R/W	0x0000	The gain smooth filter release and attack time parameter setting in expander region, which determine by the equation that $RT = 1 - \exp(-2.2Ts/tr)$ . The format is 3.24. (30ms)

**4.21.5.116. 0x2B0 ADC DRC Expander Smooth Time Low Coef Register(Default Value: 0x0000640C)**

Offset: 0x2B0			Register Name: <b>AC_ADC_DRC_EPSLC</b>
Bit	R/W	Default/Hex	Description
15:0	R/W	0x640C	The gain smooth filter release and attack time parameter setting in expander region, which determine by the equation that $RT = 1 - \exp(-2.2Ts/tr)$ . The format is 3.24. (30ms)

**4.21.5.117. 0x2B8 ADC DRC HPF Gain High Coef Register(Default Value: 0x00000100)**

Offset: 0x2B8			Register Name: <b>AC_ADC_DRC_HPFHGAIN</b>
Bit	R/W	Default/Hex	Description
15:11	/	/	/
10:0	R/W	0x0100	The gain of the hpf coefficient setting which format is 3.24.(gain = 1)

**4.21.5.118. 0x2BC ADC DRC HPF Gain Low Coef Register(Default Value: 0x00000000)**

Offset: 0x2BC			Register Name: <b>AC_ADC_DRC_HPFLGAIN</b>
Bit	R/W	Default/Hex	Description
15:0	R/W	0x0000	The gain of the hpf coefficient setting which format is 3.24.(gain = 1)

**4.21.6. Audio Codec Analog Part Register Description**

**4.21.6.1. AC Parameter Configuration Register (Default Value: 0x00000000)**

Address: 0X01F015C0			Register Name: <b>AC_PR_CFG</b>
Bit	R/W	Default/Hex	Description
31:29	/	/	/
28	R/W	0X1	AC_PR_RST AC_PR Reset 0: Assert 1: De-assert
27:25	/	/	/
24	R/W	0X0	AC_PR_RW AC_PR Read Or Write 0: read 1: write
23:21	/	/	/
20:16	R/W	0X0	AC_PR_ADDR AC_PR Address [4:0]
15:8	R/W	0X0	ADDA_PR_WDAT ADDA_PR Write Data [7:0]
7:0	R/W	0X0	ADDA_PR_RDAT ADDA_PR Read Data [7:0]

**Note:** The address of this Register is 0X01F015C0, using this register to configure the AC\_PR register.

Reset: Reset signal;

ADDR[4:0] : AC\_PR Address;

W/R: Write/Read Enable;

WDAT[7:0]: Write Data;

RDAT[7:0]: Read Data.

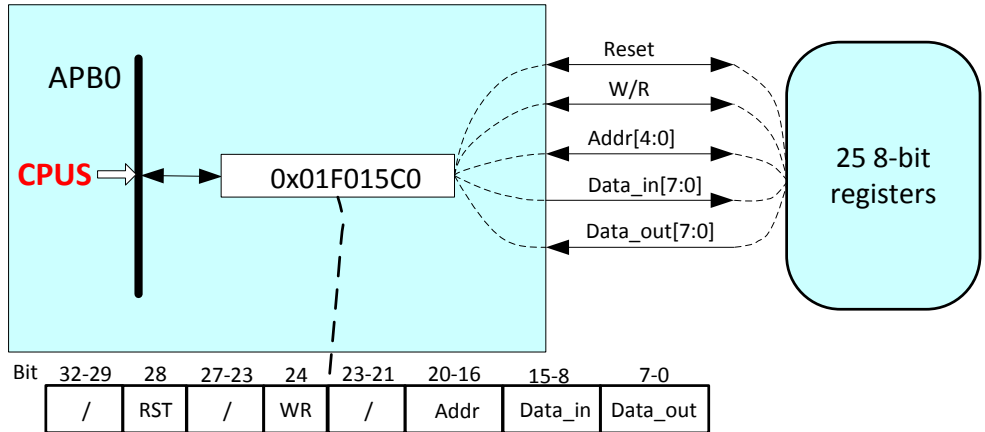

Figure 4-16. Audio Codec Analog Register Diagram

4.21.6.2. 0x00 LINEOUT PA Gating Control Register(Default Value: 0x00)

Offset:0x00			Register Name: LINEOUT_PA_GAT
Bit	R/W	Default/Hex	Description
7	R/W	0x0	PA clock gating control; when system VDD is off and Audio analog channel is working, this bit must be set to 1, because the PA clock come from system VDD domain. When this bit is 1, the Zero cross over function will be disabled automatically. 0: not gating; 1: gating
6:0	/	/	/

4.21.6.3. 0x01 Left Output Mixer Source Select Control Register(Default Value: 0x00)

Offset:0x01			Register Name: LOMIXSC
Bit	R/W	Default/Hex	Description
7	/	/	/
6:0	R/W	0x0	LMIXMUTE Left Output Mixer Mute Control 0-Mute, 1-Not Mute Bit 6: MIC1 Boost Stage Bit 5: MIC2 Boost Stage Bit 4: / Bit 3: / Bit 2: LINEINL Bit 1: Left Channel DAC Bit 0: Right Channel DAC

**4.21.6.4. 0x02 Right Output Mixer Source Select Control Register(Default Value: 0x00)**

Offset:0x02			Register Name: <b>ROMIXSC</b>
Bit	R/W	Default/Hex	Description
7	/	/	/
6:0	R/W	0x0	RMIXMUTE Right Output Mixer Mute Control 0-Mute, 1-Not Mute Bit 6: MIC1 Boost Stage Bit 5: MIC2 Boost Stage Bit 4: / Bit 3: / Bit 2: LINEINR Bit 1: Right Channel DAC Bit 0: Left Channel DAC

**4.21.6.5. 0x03 DAC Analog Enable and PA Source Control Register(Default Value: 0x00)**

Offset:0x03			Register Name: <b>DAC_PA_SRC</b>
Bit	R/W	Default/Hex	Description
7	R/W	0x0	DACAREN Internal Analog Right channel DAC Enable 0:Disable; 1:Enable
6	R/W	0x0	DACALEN Internal Analog Left channel DAC Enable 0:Disable; 1:Enable
5	R/W	0	RMIXEN Right Analog Output Mixer Enable 0:Disable; 1:Enable
4	R/W	0x0	LMIXEN Left Analog Output Mixer Enable 0:Disable; 1:Enable
3:0	/	/	/

**4.21.6.6. 0x05 Linein and Gain Control Register(Default Value: 0x30)**

Offset:0x05			Register Name: <b>LINEIN_GCTR</b>
Bit	R/W	Default/Hex	Description
7	/	/	/
6:4	R/W	0x3	LINEING, (volln) LINEINL/R to L/R output mixer Gain Control From -4.5dB to 6dB, 1.5dB/step, default is 0dB

3:0	/	/	/
-----	---	---	---

**4.21.6.7. 0x06 MIC1 And MIC2 Gain Control Register(Default Value: 0x33)**

Offset:0x06			Register Name: <b>MIC_GCTR</b>
Bit	R/W	Default/Hex	Description
7	/	/	/
6:4	R/W	0x3	MIC1_GAIN MIC1 BOOST stage to L or R output mixer Gain Control From -4.5dB to 6dB, 1.5dB/step, default is 0dB
3	/	/	/
2:0	R/W	0x3	MIC2G, (volm2) MIC2 BOOST stage to L or R output mixer Gain Control From -4.5dB to 6dB, 1.5dB/step, default is 0dB

**4.21.6.8. 0x07 PA Enable and LINEOUT Control Register(Default Value: 0x04)**

Offset:0x07			Register Name: <b>PAEN_CTR</b>
Bit	R/W	Default/Hex	Description
7	R/W	0x0	LINEOUTEN Right & Left LINEOUT Enable 0-disable 1-enable
6:4	/	/	/
3:2	R/W	0x1	PA_ANTI_POP_CTRL, (slopelengthsel) PA Anti-pop time Control 00:131ms; 01: 262ms; 10: 393ms; 11:524ms
1:0	/	/	/

**4.21.6.9. 0x09 Lineout Volume Control Register(Default Value: 0x00)**

Offset:0x09			Register Name: <b>LINEOUT_VOLC</b>
Bit	R/W	Default/Hex	Description
7:3	R/W	0x0	LINEOUTVOL Line-out Volume Control, Total 31 level, from 0dB to -48dB, 1.5dB/step, mute when 00000 & 00001
2:0	/	/	/

**4.21.6.10. 0x0A Mic2 Boost and Lineout Enable Control Register(Default Value: 0x40)**

Offset:0x0A			Register Name: <b>MIC2G_LINEOUT_CTR</b>
Bit	R/W	Default/Hex	Description
7	R/W	0x0	MIC2AMPEN MIC2 Boost AMP Enable 0-Disable; 1-Enable
6:4	R/W	0x4	MIC2BOOST MIC2 Boost AMP Gain Control 0dB when 000, 24dB to 42dB when 001 to 111, 3dB/step, default is 33dB
3	R/W	0x0	Line-out Left Select 0-not select 1-selected
2	R/W	0x0	Line-out Right Select 0-not select 1-selected
1	R/W	0x0	Left line-out source select 0-left output mixer 1-left output mixer + right output mixer
0	R/W	0x0	Right line-out source select 0-right output mixer 1-left line-out, for differential output

**4.21.6.11. 0x0B MIC1 Boost And MICBIAS Control Register(Default Value: 0x04)**

Offset:0x0B			Register Name: <b>MIC1G_MICBAIS_CTR</b>
Bit	R/W	Default/Hex	Description
7	/	/	/
6	R/W	0x0	MMICBIASEN Master Microphone Bias enable 0: disable, 1: enable
5:4	/	/	/
3	R/W	0x0	MIC1AMPEN MIC1 Boost AMP Enable 0-Disable; 1-Enable
2:0	R/W	0x4	MIC1BOOST MIC1 Boost AMP Gain Control 0dB when 000, 24dB to 42dB when 001 to 111, 3dB/step, default is 33dB

**4.21.6.12. 0x0C Left ADC Mixer Source Control Register(Default Value: 0x00)**

Offset:0x0C	Register Name: <b>LADCMIXSC</b>
-------------	---------------------------------



Bit	R/W	Default/Hex	Description
7	/	/	/
6:0	R/W	0x0	RADCMIXMUTE Right ADC Mixer Mute Control: 0-Mute, 1-Not Mute Bit 6: MIC1 Boost Stage Bit 5: MIC2 Boost Stage Bit 4: / Bit 3: / Bit 2: LINEINL Bit 1: Left Output Mixer Bit 0: Right Output Mixer

#### 4.21.6.13. 0x0D Right ADC Mixer Source Control Register(Default Value: 0x00)

Offset:0x0D			Register Name: <b>RADCMIXSC</b>
Bit	R/W	Default/Hex	Description
7	/	/	/
6:0	R/W	0x0	RADCMIXMUTE Right ADC Mixer Mute Control: 0-Mute, 1-Not Mute Bit 6: MIC1 Boost Stage Bit 5: MIC2 Boost Stage Bit 4: / Bit 3: / Bit 2: LINEINR Bit 1: Right Output Mixer Bit 0: Left Output Mixer

#### 4.21.6.14. 0x0E Reserved Register(Default Value: 0x04)

Offset:0x0E			Register Name: <b>Res_Reg</b>
Bit	R/W	Default/Hex	Description
7:6	/	/	/
5:4	R/W	0x0	MBIASSEL MMICBIAS voltage level select 00: 1.88V 01: 2.09V 10: 2.33V 11: 2.50V
3	/	/	/
2:0	R/W	0x4	PA_ANTI_POP

			PA ANTI-POP Time Control 000: 131ms 001: 262ms 010: 393ms 011: 524ms 100: 655ms 101: 786ms 110: 917ms 111: 1048ms
--	--	--	---

**4.21.6.15. 0x0F ADC Analog Part Enable Register(Default Value: 0x03)**

Offset:0x0F			Register Name: <b>ADC_AP_EN</b>
Bit	R/W	Default/Hex	Description
7	R/W	0x0	ADCREN ADC Right Channel Enable 0-Disable; 1-Enable
6	R/W	0x0	ADCLEN ADC Left Channel Enable 0-Disable; 1-Enable
5:3	/	/	/
2:0	R/W	0x3	ADCG ADC Input Gain Control From -4.5dB to 6dB, 1.5dB/step default is 0dB

**4.21.6.16. 0x10 ADDA Analog Performance Turning 0 Register(Default Value: 0x55)**

Offset:0x10			Register Name: <b>ADDA_APT0</b>
Bit	R/W	Default/Hex	Description
7:6	R/W	0x1	OPDRV_OPCOM_CUR. OPDRV/OPCOM output stage current setting
5:4	R/W	0x1	OPADC1_BIAS_CUR. OPADC1 Bias Current Select
3:2	R/W	0x1	OPADC2_BIAS_CUR. OPADC2 Bias Current Select
1:0	R/W	0x1	OPAAF_BIAS_CUR. OPAAF in ADC Bias Current Select

**4.21.6.17. 0x11 ADDA Analog Performance Turning 1 Register(Default Value: 0x45)**

Offset:0x11			Register Name: <b>ADDA_APT1</b>
-------------	--	--	---------------------------------

Bit	R/W	Default/Hex	Description
7:6	R/W	0x1	OPMIC_BIAS_CUR OPMIC Bias Current Control
5:4	/	/	/
3:2	R/W	0x1	OPDAC_BIAS_CUR. OPDAC Bias Current Control
1:0	R/W	0x1	OPMIX_BIAS_CUR. OPMIX/OPLPF Bias Current Control

**4.21.6.18. 0x12 ADDA Analog Performance Turning 2 Register(Default Value: 0x42)**

Offset:0x12			Register Name: <b>ADDA_APT2</b>
Bit	R/W	Default/Hex	Description
7	R/W	0x0	function enable for master volume change at zero cross over 0: disable; 1: enable
6	R/W	0x1	Timeout control for master volume change at zero cross over 0: 32ms; 1: 64ms
5:4	R/W	0x0	PTDBS HPCOM protect de-bounce time setting 00: 2-3ms; 01: 4-6ms; 10: 8-12ms; 11: 16-24ms at the same time, bit 17 is used to control the AVCCPORFLAG, write 1 to this bit, flag will be clear, and the calibration is done again
3	R/W	0x0	PA_SLOPE_SELECT PA slope select cosine or ramp 0: select cosine 1: select ramp
2:0	R/W	0x2	USB_BIAS_CUR. USB bias current tuning From 23uA to 30uA, Default is 25uA

**4.21.6.19. 0x13 Bias & DA16 Calibration Control Register0(Default Value: 0xD6)**

Offset:0x13			Register Name: Bias_DA16_CAL_CTRL0
Bit	R/W	Default/Hex	Description
7	R/W	0x1	MMIC BIAS chopper enable 0: disable; 1:enable
6:5	R/W	0x2	MMIC BIAS chopper clock select 00: 250KHz; 01: 500KHz; 10: 1MHz; 11: 2MHz
4	R/W	0x1	DITHER ADC dither on/off control 0: dither off; 1: dither on
3:2	R/W	0x1	DITHER_CLK_SELECT

			ADC dither clock select 00: ADC FS * (8/9), about 43KHz when FS=48KHz 01: ADC FS * (16/15), about 51KHz when FS=48KHz 10: ADC FS * (4/3), about 64KHz when FS=48KHz 11: ADC FS * (16/9), about 85KHz when FS=48KHz
1:0	R/W	0x2	BIHE_CTRL, BIHE control 00: no BIHE 01: BIHE=7.5 HOSC 10: BIHE=11.5 HOSC 11: BIHE=15.5 HOSC

**4.21.6.20. 0x14 Bias & DA16 Calibration Control Register1(Default Value: 0x00)**

Offset:0x14			Register Name: <b>Bias_DA16_CAL_CTR1</b>
Bit	R/W	Default/Hex	Description
7	R/W	0x0	PA_SPEED_SELECT PA setup speed control (for testing) 0: slow; 1: fast
6	R/W	0x0	CURRENT_TEST_SELECT Internal current sink test enable (from LINEIN pin) 0:Normal; 1: For Debug
5	R/W	0x0	/
4	R/W	0x0	BIAS and DA16 calibration clock select 0: 1KHz; 1: 500Hz
3	R/W	0x0	BIAS calibration mode select 0: average; 1: single
2	R/W	0x0	BIAS and DA16 calibration control Write 1 to this bit, the calibration will be doing again. Then this bit will be reset to zero automatically
1	R/W	0x0	BIASCALIVERIFY Bias Calibration Verify 0: Calibration; 1: Register setting
0	R/W	0x0	DA16CALIVERIFY DA16 Calibration Verify 0: Calibration; 1: Register setting

**4.21.6.21. 0x15 DA16 Calibration Data Register(Default Value: 0x80)**

Offset:0x15			Register Name: <b>DA16CALI</b>
Bit	R/W	Default/Hex	Description
7:0	R	0x80	DA16CALI DA16 Calibration Data

**4.21.6.22. 0x16 DA16 Register Setting Data Register(Default Value: 0x80)**

Offset:0x16			Register Name: <b>DA16VERIFY</b>
Bit	R/W	Default/Hex	Description
7:0	R/W	0x80	/

**4.21.6.23. 0x17 Bias Calibration Data Register(Default Value: 0x20)**

Offset:0x17			Register Name: <b>BIASCALI</b>
Bit	R/W	Default/Hex	Description
7:0	R	0x20	BIASCALI Bias Calibration Data, 6bit

**4.21.6.24. 0x18 Bias Register Setting Data Register(Default Value: 0x20)**

Offset:0x18			Register Name: <b>BIASVERIFY</b>
Bit	R/W	Default/Hex	Description
7:0	R/W	0x20	BIASVERIFY Bias Register Setting Data, 6bit

Confidential

## 4.22. Port Controller(CPU-PORT)

The chip has 7 ports for multi-functional input/out pins. They are shown below:

- Port A(PA): 22 input/output port
- Port C(PC): 19 input/output port
- Port D(PD): 18 input/output port
- Port E(PE) : 16 input/output port
- Port F(PF) : 7 input/output port
- Port G(PG) : 14 input/output port
- Port L(PL) : 12 input/output port

For various system configurations, these ports can be easily configured by software. All these ports can be configured as GPIO if multiplexed functions are not used. The total 2 group external PIO interrupt sources are supported and interrupt mode can be configured by software.

### 4.22.1. Port Controller Register List

Module Name	Base Address
PIO	0x01C20800

Register Name	Offset	Description
Pn_CFG0	n*0x24+0x00	Port n Configure Register 0 (n from 0 to 6)
Pn_CFG1	n*0x24+0x04	Port n Configure Register 1 (n from 0 to 6)
Pn_CFG2	n*0x24+0x08	Port n Configure Register 2 (n from 0 to 6)
Pn_CFG3	n*0x24+0x0C	Port n Configure Register 3 (n from 0 to 6)
Pn_DAT	n*0x24+0x10	Port n Data Register (n from 0 to 6)
Pn_DRV0	n*0x24+0x14	Port n Multi-Driving Register 0 (n from 0 to 6)
Pn_DRV1	n*0x24+0x18	Port n Multi-Driving Register 1 (n from 0 to 6)
Pn_PUL0	n*0x24+0x1C	Port n Pull Register 0 (n from 0 to 6)
Pn_PUL1	n*0x24+0x20	Port n Pull Register 1 (n from 0 to 6)
PA_INT_CFG0	0x200+0*0x20+0x00	PIO Interrupt Configure Register 0
PA_INT_CFG1	0x200+0*0x20+0x04	PIO Interrupt Configure Register 1
PA_INT_CFG2	0x200+0*0x20+0x08	PIO Interrupt Configure Register 2
PA_INT_CFG3	0x200+0*0x20+0x0C	PIO Interrupt Configure Register 3
PA_INT_CTL	0x200+0*0x20+0x10	PIO Interrupt Control Register
PA_INT_STA	0x200+0*0x20+0x14	PIO Interrupt Status Register
PA_INT_DEB	0x200+0*0x20+0x18	PIO Interrupt Debounce Register
PG_INT_CFG0	0x200+1*0x20+0x00	PIO Interrupt Configure Register 0
PG_INT_CFG1	0x200+1*0x20+0x04	PIO Interrupt Configure Register 1
PG_INT_CFG2	0x200+1*0x20+0x08	PIO Interrupt Configure Register 2
PG_INT_CFG3	0x200+1*0x20+0x0C	PIO Interrupt Configure Register 3

PG_INT_CTL	0x200+1*0x20+0x10	PIO Interrupt Control Register
PG_INT_STA	0x200+1*0x20+0x14	PIO Interrupt Status Register
PG_INT_DEB	0x200+1*0x20+0x18	PIO Interrupt Debounce Register

## 4.22.2. Port Controller Register Description

### 4.22.2.1. PA Configure Register 0 (Default Value: 0x77777777)

Offset: 0x00			Register Name: PA_CFG0_REG
Bit	R/W	Default/Hex	Description
31	/	/	/
30:28	R/W	0x7	PA7_SELECT 000:Input                    001:Output 010:SIM_CLK                011:Reserved 100:Reserved               101:Reserved 110:PA_EINT7               111:IO Disable
27	/	/	/
26:24	R/W	0x7	PA6_SELECT 000:Input                    001:Output 010:SIM_PWREN             011:PWM1 100:Reserved               101:Reserved 110:PA_EINT6               111:IO Disable
23	/	/	/
22:20	R/W	0x7	PA5_SELECT 000:Input                    001:Output 010:UART0_RX              011:PWM0 100:Reserved               101:Reserved 110:PA_EINT5               111:IO Disable
19	/	/	/
18:16	R/W	0x7	PA4_SELECT 000:Input                    001:Output 010:UART0_TX              011:Reserved 100:Reserved               101:Reserved 110:PA_EINT4               111:IO Disable
15	/	/	/
14:12	R/W	0x7	PA3_SELECT 000:Input                    001:Output 010:UART2_CTS             011:JTAG_DI 100:Reserved               101:Reserved 110:PA_EINT3               111:IO Disable
11	/	/	/
10:8	R/W	0x7	PA2_SELECT 000:Input                    001:Output

			010:UART2_RTS 100:Reserved 110:PA_EINT2	011:JTAG_DO 101:Reserved 111:IO Disable
7	/	/	/	
6:4	R/W	0x7	PA1_SELECT 000:Input 010:UART2_RX 100:Reserved 110:PA_EINT1	001:Output 011:JTAG_CK 101:Reserved 111:IO Disable
3	/	/	/	
2:0	R/W	0x7	PA0_SELECT 000:Input 010:UART2_TX 100:Reserved 110:PA_EINT0	001:Output 011:JTAG_MS 101:Reserved 111:IO Disable

#### 4.22.2.2. PA Configure Register 1 (Default Value: 0x77777777)

Offset: 0x04			Register Name: PA_CFG1_REG	
Bit	R/W	Default/Hex	Description	
31	/	/	/	
30:28	R/W	0x7	PA15_SELECT 000:Input 010:SPI1_MOSI 100:Reserved 110:PA_EINT15	001:Output 011:UART3_RTS 101:Reserved 111:IO Disable
27	/	/	/	
26:24	R/W	0x7	PA14_SELECT 000:Input 010:SPI1_CLK 100:Reserved 110:PA_EINT14	001:Output 011:UART3_RX 101:Reserved 111:IO Disable
23	/	/	/	
22:20	R/W	0x7	PA13_SELECT 000:Input 010:SPI1_CS 100:Reserved 110:PA_EINT13	001:Output 011:UART3_TX 101:Reserved 111:IO Disable
19	/	/	/	
18:16	R/W	0x7	PA12_SELECT 000:Input 010:TWIO_SDA 100:Reserved 110:PA_EINT12	001:Output 011:DI_RX 101:Reserved 111:IO Disable



15	/	/	
14:12	R/W	0x7	PA11_SELECT 000:Input                      001:Output 010:TWI0_SCK                011:DI_TX 100:Reserved                 101:Reserved 110:PA_EINT11               111:IO Disable
11	/	/	/
10:8	R/W	0x7	PA10_SELECT 000:Input                      001:Output 010:SIM_DET                 011:Reserved 100:Reserved                 101:Reserved 110:PA_EINT10               111:IO Disable
7	/	/	
6:4	R/W	0x7	PA9_SELECT 000:Input                      001:Output 010:SIM_RST                 011:Reserved 100:Reserved                 101:Reserved 110:PA_EINT9                111:IO Disable
3	/	/	
2:0	R/W	0x7	PA8_SELECT 000:Input                      001:Output 010:SIM_DATA                011:Reserved 100:Reserved                 101:Reserved 110:PA_EINT8                111:IO Disable

#### 4.22.2.3. PA Configure Register 2 (Default Value: 0x00777777)

Offset: 0x08			Register Name: PA_CFG2_REG
Bit	R/W	Default/Hex	Description
31:23	/	/	
22:20	R/W	0x7	PA21_SELECT 000:Input                      001:Output 010:PCM0_DIN                011:SIM_VPPPP 100:Reserved                 101:Reserved 110:PA_EINT21               111:IO Disable
19	/	/	
18:16	R/W	0x7	PA20_SELECT 000:Input                      001:Output 010:PCM0_DOUT               011:SIM_VPPEN 100:Reserved                 101:Reserved 110:PA_EINT20               111:IO Disable
15	/	/	
14:12	R/W	0x7	PA19_SELECT 000:Input                      001:Output

			010:PCM0_CLK 100:Reserved 110:PA_EINT19	011:TWI1_SDA 101:Reserved 111:IO Disable
11	/	/	/	
10:8	R/W	0x7	PA18_SELECT 000:Input 010:PCM0_SYNC 100:Reserved 110:PA_EINT18	001:Output 011:TWI1_SCK 101:Reserved 111:IO Disable
7	/	/		
6:4	R/W	0x7	PA17_SELECT 000:Input 010:OWA_OUT 100:Reserved 110:PA_EINT17	001:Output 011:Reserved 101:Reserved 111:IO Disable
3	/	/		
2:0	R/W	0x7	PA16_SELECT 000:Input 010:SPI1_MISO 100:Reserved 110:PA_EINT16	001:Output 011:UART3_CTS 101:Reserved 111:IO Disable

#### 4.22.2.4. PA Configure Register 3 (Default Value: 0x00000000)

Offset: 0x0C			Register Name: <b>PA_CFG3_REG</b>
Bit	R/W	Default/Hex	Description
31:0	/	/	/

#### 4.22.2.5. PA Data Register (Default Value: 0x00000000)

Offset: 0x10			Register Name: <b>PA_DATA_REG</b>
Bit	R/W	Default/Hex	Description
31:22	/	/	/
21:0	R/W	0x0	PA_DAT If the port is configured as input, the corresponding bit is the pin state. If the port is configured as output, the pin state is the same as the corresponding bit. The read bit value is the value setup by software. If the port is configured as functional pin, the undefined value will be read.

**4.22.2.6. PA Multi-Driving Register 0 (Default Value: 0x55555555)**

Offset: 0x14			Register Name: <b>PA_DRV0_REG</b>
Bit	R/W	Default/Hex	Description
[2i+1:2i] (i=0~15)	R/W	0x1	PA_DRV PA[n] Multi-Driving Select (n = 0~15) 00: Level 0                      01: Level 1 10: Level 2                      11: Level 3

**4.22.2.7. PA Multi-Driving Register 1 (Default Value: 0x00000555)**

Offset: 0x18			Register Name: <b>PA_DRV1_REG</b>
Bit	R/W	Default/Hex	Description
31:12	/	/	/
[2i+1:2i] (i=0~5)	R/W	0x1	PA_DRV PA[n] Multi-Driving Select (n = 16~21) 00: Level 0                      01: Level 1 10: Level 2                      11: Level 3

**4.22.2.8. PA PULL Register 0 (Default Value: 0x00000000)**

Offset: 0x1C			Register Name: <b>PA_PULL0_REG</b>
Bit	R/W	Default/Hex	Description
[2i+1:2i] (i=0~15)	R/W	0x0	PA_PULL PA[n] Pull-up/down Select (n = 0~15) 00: Pull-up/down disable    01: Pull-up 10: Pull-down                    11: Reserved

**4.22.2.9. PA PULL Register 1 (Default Value: 0x00000000)**

Offset: 0x20			Register Name: <b>PA_PULL1_REG</b>
Bit	R/W	Default/Hex	Description
31:12	/	/	/
[2i+1:2i] (i=0~5)	R/W	0x0	PA_PULL PA[n] Pull-up/down Select (n = 16~21) 00: Pull-up/down disable    01: Pull-up 10: Pull-down                    11: Reserved

**4.22.2.10. PC Configure Register 0 (Default Value: 0x77777777)**

Offset: 0x48			Register Name: <b>PC_CFG0_REG</b>
Bit	R/W	Default/Hex	Description
31	/	/	/
30:28	R/W	0x7	PC7_SELECT 000:Input                    001:Output 010:NAND_RB1                011:Reserved 100:Reserved                 101:Reserved 110:Reserved                 111:IO Disable
27	/	/	/
26:24	R/W	0x7	PC6_SELECT 000:Input                    001:Output 010:NAND_RBO                011:SDC2_CMD 100:Reserved                 101:Reserved 110:Reserved                 111:IO Disable
23	/	/	/
22:20	R/W	0x7	PC5_SELECT 000:Input                    001:Output 010:NAND_RE                 011:SDC2_CLK 100:Reserved                 101:Reserved 110:Reserved                 111:IO Disable
19	/	/	/
18:16	R/W	0x7	PC4_SELECT 000:Input                    001:Output 010:NAND_CEO                 011:Reserved 100:Reserved                 101:Reserved 110:Reserved                 111:IO Disable
15	/	/	/
14:12	R/W	0x7	PC3_SELECT 000:Input                    001:Output 010:NAND_CE1                 011:SPIO_CS 100:Reserved                 101:Reserved 110:Reserved                 111:IO Disable
11	/	/	/
10:8	R/W	0x7	PC2_SELECT 000:Input                    001:Output 010:NAND_CLE                 011:SPIO_CLK 100:Reserved                 101:Reserved 110:Reserved                 111:IO Disable
7	/	/	/
6:4	R/W	0x7	PC1_SELECT 000:Input                    001:Output 010:NAND_ALE                 011:SPIO_MISO

			100:Reserved 110:Reserved	101:Reserved 111:IO Disable
3	/	/	/	
2:0	R/W	0x7	PC0_SELECT 000:Input 010:NAND_WE 100:Reserved 110:Reserved	001:Output 011:SPIO_MOSI 101:Reserved 111:IO Disable

**4.22.2.11. PC Configure Register 1 (Default Value: 0x77777777)**

Offset: 0x4C			Register Name: <b>PC_CFG1_REG</b>	
Bit	R/W	Default/Hex	Description	
31	/	/	/	
30:28	R/W	0x7	PC15_SELECT 000:Input 010:NAND_DQ7 100:Reserved 110:Reserved	001:Output 011:SDC2_D7 101:Reserved 111:IO Disable
27	/	/	/	
26:24	R/W	0x7	PC14_SELECT 000:Input 010:NAND_DQ6 100:Reserved 110:Reserved	001:Output 011:SDC2_D6 101:Reserved 111:IO Disable
23	/	/	/	
22:20	R/W	0x7	PC13_SELECT 000:Input 010:NAND_DQ5 100:Reserved 110:Reserved	001:Output 011:SDC2_D5 101:Reserved 111:IO Disable
19	/	/	/	
18:16	R/W	0x7	PC12_SELECT 000:Input 010:NAND_DQ4 100:Reserved 110:Reserved	001:Output 011:SDC2_D4 101:Reserved 111:IO Disable
15	/	/	/	
14:12	R/W	0x7	PC11_SELECT 000:Input 010:NAND_DQ3 100:Reserved 110:Reserved	001:Output 011:SDC2_D3 101:Reserved 111:IO Disable
11	/	/	/	

10:8	R/W	0x7	PC10_SELECT 000:Input                      001:Output 010:NAND_DQ2                011:SDC2_D2 100:Reserved                101:Reserved 110:Reserved                111:IO Disable
7	/	/	/
6:4	R/W	0x7	PC9_SELECT 000:Input                      001:Output 010:NAND_DQ1                011:SDC2_D1 100:Reserved                101:Reserved 110:Reserved                111:IO Disable
3	/	/	/
2:0	R/W	0x7	PC8_SELECT 000:Input                      001:Output 010:NAND_DQ0                011:SDC2_D0 100:Reserved                101:Reserved 110:Reserved                111:IO Disable

**4.22.2.12. PC Configure Register 2 (Default Value: 0x00000777)**

Offset: 0x50			Register Name: <b>PC_CFG2_REG</b>
Bit	R/W	Default/Hex	Description
31:11	/	/	/
10:8	R/W	0x7	/
7	/	/	/
6:4	R/W	0x7	/
3	/	/	/
2:0	R/W	0x7	PC16_SELECT 000:Input                      001:Output 010:NAND_DQS                011:SDC2_RST 100:Reserved                101:Reserved 110:Reserved                111:IO Disable

**4.22.2.13. PC Configure Register 3 (Default Value: 0x00000000)**

Offset: 0x54			Register Name: <b>PC_CFG3_REG</b>
Bit	R/W	Default/Hex	Description
31:0	/	/	/

**4.22.2.14. PC Data Register (Default Value: 0x00000000)**

Offset: 0x58			Register Name: <b>PC_DATA_REG</b>
Bit	R/W	Default/Hex	Description
31:19	/	/	/
18:0	R/W	0x0	PC_DAT If the port is configured as input, the corresponding bit is the pin state. If the port is configured as output, the pin state is the same as the corresponding bit. The read bit value is the value setup by software. If the port is configured as functional pin, the undefined value will be read.

**4.22.2.15. PC Multi-Driving Register 0 (Default Value: 0x55555555)**

Offset: 0x5C			Register Name: <b>PC_DRV0_REG</b>
Bit	R/W	Default/Hex	Description
[2i+1:2i] (i=0~15)	R/W	0x1	PC_DRV PC[n] Multi-Driving SELECT (n = 0~15) 00: Level 0                      01: Level 1 10: Level 2                     11: Level 3

**4.22.2.16. PC Multi-Driving Register 1 (Default Value: 0x00000015)**

Offset: 0x60			Register Name: <b>PC_DRV1_REG</b>
Bit	R/W	Default/Hex	Description
31:6	/	/	/
[2i+1:2i] (i=0~2)	R/W	0x1	PC_DRV PC[n] Multi-Driving Select (n = 16~18) 00: Level 0                      01: Level 1 10: Level 2                     11: Level 3

**4.22.2.17. PC PULL Register 0 (Default Value: 0x00005140)**

Offset: 0x64			Register Name: <b>PC_PULL0_REG</b>
Bit	R/W	Default/Hex	Description
[2i+1:2i] (i=0~15)	R/W	0x5140	PC_PULL PC[n] Pull-up/down Select (n = 0~15) 00: Pull-up/down disable    01: Pull-up 10: Pull-down                    11: Reserved

**4.22.2.18. PC PULL Register 1 (Default Value: 0x00000014)**

Offset: 0x68			Register Name: <b>PC_PULL1_REG</b>
Bit	R/W	Default/Hex	Description
31:6	/	/	Reserved
[2i+1:2i] (i=0~2)	R/W	0x14	PC_PULL PC[n] Pull-up/down Select (n = 16~18) 00: Pull-up/down disable    01: Pull-up 10: Pull-down                    11: Reserved

**4.22.2.19. PD Configure Register 0 (Default Value: 0x77777777)**

Offset: 0x6C			Register Name: <b>PD_CFG0_REG</b>
Bit	R/W	Default/Hex	Description
31	/	/	/
30:28	R/W	0x7	PD7_SELECT 000:Input                            001:Output 010:RGMII_TXD3/MII_TXD3/RMII_NULL                    011:Reserved 100:Reserved                    101:Reserved 110:Reserved                    111:IO Disable
27	/	/	Reserved
26:24	R/W	0x7	PD6_SELECT 000:Input                            001:Output 010:RGMII_NULL/MII_RXERR/RMII_RXER                    011:Reserved 100:Reserved                    101:Reserved 110:Reserved                    111:IO Disable
23	/	/	/
22:20	R/W	0x7	PD5_SELECT 000:Input                            001:Output 010:RGMII_RXCTL/MII_RXDV/RMII_NULL                    011:Reserved 100:Reserved                    101:Reserved 110:Reserved                    111:IO Disable
19	/	/	/
18:16	R/W	0x7	PD4_SELECT 000:Input                            001:Output 010:RGMII_RXCK/MII_RXCK/RMII_NULL                    011:Reserved 100:Reserved                    101:Reserved 110:Reserved                    111:IO Disable
15	/	/	/
14:12	R/W	0x7	PD3_SELECT 000:Input                            001:Output 010:RGMII_RXD0/MII_RXD0/RMII_RXD0                    011:Reserved 100:Reserved                    101:Reserved



			110:Reserved	111:IO Disable
11	/	/	/	
10:8	R/W	0x7	PD2_SELECT 000:Input                      001:Output 010:RGMII_RXD1/MII_RXD1/RMII_RXD1                      011:Reserved 100:Reserved                      101:Reserved 110:Reserved                      111:IO Disable	
7	/	/	/	
6:4	R/W	0x7	PD1_SELECT 000:Input                      001:Output 010:RGMII_RXD2/MII_RXD2/RMII_NULL                      011:DI_RX 100:Reserved                      101:Reserved 110:Reserved                      111:IO Disable	
3	/	/	/	
2:0	R/W	0x7	PD0_SELECT 000:Input                      001:Output 010:RGMII_RXD3/ MII_RXD3/ RMII_NULL                      011:DI_TX 100:Reserved                      101:Reserved 110:Reserved                      111:IO Disable	

**4.22.2.20. PD Configure Register 1 (Default Value: 0x77777777)**

Offset: 0x70			Register Name: PD_CFG1_REG
Bit	R/W	Default/Hex	Description
31	/	/	/
30:28	R/W	0x7	PD15_SELECT 000:Input                      001:Output 010:RGMII_CLKIN/MII_COL/RMII_NULL                      011:Reserved 100:Reserved                      101:Reserved 110:Reserved                      111:IO Disable
27	/	/	/
26:24	R/W	0x7	PD14_SELECT 000:Input                      001:Output 010:RGMII_NULL/MII_TXERR/RMII_NULL                      011:Reserved 100:Reserved                      101:Reserved 110:Reserved                      111:IO Disable
23	/	/	/
22:20	R/W	0x7	PD13_SELECT 000:Input                      001:Output 010:RGMII_TXCTL/MII_TXEN/RMII_TXEN                      011:Reserved 100:Reserved                      101:Reserved 110:Reserved                      111:IO Disable
19	/	/	/
18:16	R/W	0x7	PD12_SELECT

			000:Input 010:RGMII_TXCK/MII_TXCK/RMII_TXCK 100:Reserved 110:Reserved	001:Output 011:Reserved 101:Reserved 111:IO Disable
15	/	/	/	/
14:12	R/W	0x7	PD11_SELECT 000:Input 010:RGMII_NULL/MII_CR5/RMII_NULL 100:Reserved 110:Reserved	001:Output 011:Reserved 101:Reserved 111:IO Disable
11	/	/	/	/
10:8	R/W	0x7	PD10_SELECT 000:Input 010:RGMII_TXD0/MII_TXD0/RMII_TXD0 100:Reserved 110:Reserved	001:Output 011:Reserved 101:Reserved 111:IO Disable
7	/	/	/	/
6:4	R/W	0x7	PD9_SELECT 000:Input 010:RGMII_TXD1/MII_TXD1/RMII_TXD1 100:Reserved 110:Reserved	001:Output 011:Reserved 101:Reserved 111:IO Disable
3	/	/	/	/
2:0	R/W	0x7	PD8_SELECT 000:Input 010:RGMII_TXD2/MII_TXD2/RMII_NULL 100:Reserved 110:Reserved	001:Output 011:Reserved 101:Reserved 111:IO Disable

**4.22.2.21. PD Configure Register 2 (Default Value: 0x00000077)**

Offset: 0x74			Register Name: PD_CFG2_REG	
Bit	R/W	Default/Hex	Description	
31:7	/	/	/	
6:4	R/W	0x7	PD17_SELECT 000:Input 010:MDIO 100:Reserved 110:Reserved	001:Output 011:Reserved 101:Reserved 111:IO Disable
3	/	/	/	/
2:0	R/W	0x7	PD16_SELECT 000:Input 010:MDC 100:Reserved	001:Output 011:Reserved 101:Reserved

		110:Reserved	111:IO Disable
--	--	--------------	----------------

**4.22.2.22. PD Configure Register 3 (Default Value: 0x00000000)**

Offset: 0x78			Register Name: <b>PD_CFG3_REG</b>
Bit	R/W	Default/Hex	Description
31:0	/	/	/

**4.22.2.23. PD Data Register (Default Value: 0x00000000)**

Offset: 0x7C			Register Name: <b>PD_DATA_REG</b>
Bit	R/W	Default/Hex	Description
31:18	/	/	/
17:0	R/W	0x0	PD_DAT If the port is configured as input, the corresponding bit is the pin state. If the port is configured as output, the pin state is the same as the corresponding bit. The read bit value is the value setup by software. If the port is configured as functional pin, the undefined value will be read.

**4.22.2.24. PD Multi-Driving Register 0 (Default Value: 0x55555555)**

Offset: 0x80			Register Name: <b>PD_DRV0_REG</b>
Bit	R/W	Default/Hex	Description
[2i+1:2i] (i=0~15)	R/W	0x1	PD_DRV PD[n] Multi-Driving SELECT (n = 0~15) 00: Level 0                      01: Level 1 10: Level 2                      11: Level 3

**4.22.2.25. PD Multi-Driving Register 1 (Default Value: 0x00000005)**

Offset: 0x84			Register Name: <b>PD_DRV1_REG</b>
Bit	R/W	Default/Hex	Description
31:4	/	/	/
[2i+1:2i] (i=0~1)	R/W	0x1	PD_DRV PD[n] Multi-Driving Select (n = 16~17) 00: Level 0                      01: Level 1 10: Level 2                      11: Level 3

**4.22.2.26. PD PULL Register 0 (Default Value: 0x00000000)**

Offset: 0x88			Register Name: <b>PD_PULL0_REG</b>
Bit	R/W	Default/Hex	Description
[2i+1:2i] (i=0~15)	R/W	0x0	PD_PULL PD[n] Pull-up/down Select (n = 0~15) 00: Pull-up/down disable    01: Pull-up 10: Pull-down                    11: Reserved

**4.22.2.27. PD PULL Register 1 (Default Value: 0x00000000)**

Offset: 0x8C			Register Name: <b>PD_PULL1_REG</b>
Bit	R/W	Default/Hex	Description
31:4	/	/	Reserved
[2i+1:2i] (i=0~1)	R/W	0x0	PD_PULL PD[n] Pull-up/down Select (n = 16~17) 00: Pull-up/down disable    01: Pull-up 10: Pull-down                    11: Reserved

**4.22.2.28. PE Configure Register 0 (Default Value: 0x77777777)**

Offset: 0x90			Register Name: <b>PE_CFG0_REG</b>
Bit	R/W	Default/Hex	Description
31	/	/	/
30:28	R/W	0x7	PE7_SELECT 000:Input                    001:Output 010:CSI_D3                011:TS_D3 100: Reserved            101:Reserved 110:Reserved            111:IO Disable
27	/	/	/
26:24	R/W	0x7	PE6_SELECT 000:Input                    001:Output 010:CSI_D2                011:TS_D2 100: Reserved            101:Reserved 110:Reserved            111:IO Disable
23	/	/	/
22:20	R/W	0x7	PE5_SELECT 000:Input                    001:Output 010: CSI_D1                011:TS_D1 100: Reserved            101:Reserved 110:Reserved            111:IO Disable
19	/	/	/

18:16	R/W	0x7	PE4_SELECT 000:Input 010: CSI_D0 100: Reserved 110:Reserved	001:Output 011:TS_D0 101:Reserved 111:IO Disable
15	/	/	/	/
14:12	R/W	0x7	PE3_SELECT 000:Input 010:CSI_VSYNC 100: Reserved 110:Reserved	001:Output 011:TS_DVLD 101:Reserved 111:IO Disable
11	/	/	/	/
10:8	R/W	0x7	PE2_SELECT 000:Input 010:CSI_HSYNC 100:Reserved 110:Reserved	001:Output 011:TS_SYNC 101:Reserved 111:IO Disable
7	/	/	/	/
6:4	R/W	0x7	PE1_SELECT 000:Input 010:CSI_MCLK 100:Reserved 110:Reserved	001:Output 011:TS_ERR 101:Reserved 111:IO Disable
3	/	/	/	/
2:0	R/W	0x7	PE0_SELECT 000:Input 010:CSI_PCLK 100:Reserved 110:Reserved	001:Output 011:TS_CLK 101:Reserved 111:IO Disable

**4.22.2.29. PE Configure Register 1 (Default Value: 0x77777777)**

Offset: 0x94			Register Name: <b>PE_CFG1_REG</b>	
Bit	R/W	Default/Hex	Description	
31	/	/	/	
30:28	R/W	0x7	PE15_SELECT 000:Input 010: Reserved 100: Reserved 110:Reserved	001:Output 011: Reserved 101:Reserved 111:IO Disable
27	/	/	/	/
26:24	R/W	0x7	PE14_SELECT 000:Input 010: Reserved	001:Output 011: Reserved

			100: Reserved 110:Reserved	101:Reserved 111:IO Disable
23	/	/	/	
22:20	R/W	0x7	PE13_SELECT 000:Input 010: CSI_SDA 100: Reserved 110:Reserved	001:Output 011: TWI2_SDA 101:Reserved 111:IO Disable
19	/	/	/	
18:16	R/W	0x7	PE12_SELECT 000:Input 010: CSI_SCK 100: Reserved 110:Reserved	001:Output 011: TWI2_SCK 101:Reserved 111:IO Disable
15	/	/	/	
14:12	R/W	0x7	PE11_SELECT 000:Input 010:CSI_D7 100: Reserved 110:Reserved	001:Output 011: TS_D7 101:Reserved 111:IO Disable
11	/	/	/	
10:8	R/W	0x7	PE10_SELECT 000:Input 010:CSI_D6 100: Reserved 110:Reserved	001:Output 011: TS_D6 101:Reserved 111:IO Disable
7	/	/	/	
6:4	R/W	0x7	PE9_SELECT 000:Input 010:CSI_D5 100: Reserved 110:Reserved	001:Output 011: TS_D5 101:Reserved 111:IO Disable
3	/	/	/	
2:0	R/W	0x7	PE8_SELECT 000:Input 010:CSI_D4 100: Reserved 110:Reserved	001:Output 011: TS_D4 101:Reserved 111:IO Disable

#### 4.22.2.30. PE Configure Register 2 (Default Value: 0x00000000)

Offset: 0x98			Register Name: <b>PE_CFG2_REG</b>
Bit	R/W	Default/Hex	Description
31:0	/	/	/

**4.22.2.31. PE Configure Register 3 (Default Value: 0x00000000)**

Offset: 0x9C			Register Name: <b>PE_CFG3_REG</b>
Bit	R/W	Default/Hex	Description
31:0	/	/	/

**4.22.2.32. PE Data Register (Default Value: 0x00000000)**

Offset: 0xA0			Register Name: <b>PE_DATA_REG</b>
Bit	R/W	Default/Hex	Description
31:16	/	/	/
15:0	R/W	0x0	PE_DAT If the port is configured as input, the corresponding bit is the pin state. If the port is configured as output, the pin state is the same as the corresponding bit. The read bit value is the value setup by software. If the port is configured as functional pin, the undefined value will be read.

**4.22.2.33. PE Multi-Driving Register 0 (Default Value: 0x55555555)**

Offset: 0xA4			Register Name: <b>PE_DRV0_REG</b>
Bit	R/W	Default/Hex	Description
[2i+1:2i] (i=0~15)	R/W	0x1	PE_DRV PE[n] Multi-Driving SELECT (n = 0~15) 00: Level 0                      01: Level 1 10: Level 2                     11: Level 3

**4.22.2.34. PE Multi-Driving Register 1 (Default Value: 0x00000000)**

Offset: 0xA8			Register Name: <b>PE_DRV1_REG</b>
Bit	R/W	Default/Hex	Description
31:0	/	/	/

**4.22.2.35. PE PULL Register 0 (Default Value: 0x00000000)**

Offset: 0xAC			Register Name: <b>PE_PULL0_REG</b>
Bit	R/W	Default/Hex	Description
[2i+1:2i] (i=0~15)	R/W	0x0	PE_PULL PE[n] Pull-up/down Select (n = 0~15)

			00: Pull-up/down disable 10: Pull-down	01: Pull-up 11: Reserved
--	--	--	---	-----------------------------

**4.22.2.36. PE PULL Register 1 (Default Value: 0x00000000)**

Offset: 0xB0			Register Name: <b>PE_PULL1_REG</b>
Bit	R/W	Default/Hex	Description
31:0	/	/	/

**4.22.2.37. PF Configure Register 0 (Default Value: 0x07373733)**

Offset: 0xB4			Register Name: <b>PF_CFG0_REG</b>
Bit	R/W	Default/Hex	Description
31:27	/	/	/
26:24	R/W	0x7	PF6_SELECT 000:Input                      001:Output 010: Reserved                011:Reserved 100:Reserved                101:Reserved 110:Reserved                111:IO Disable
23			
22:20	R/W	0x3	PF5_SELECT 000:Input                      001:Output 010:SDC0_D2                011:JTAG_CK 100:Reserved                101:Reserved 110:Reserved                111:IO Disable
19	/	/	/
18:16	R/W	0x7	PF4_SELECT 000:Input                      001:Output 010:SDC0_D3                011:UART0_RX 100:Reserved                101:Reserved 110:Reserved                111:IO Disable
15	/	/	/
14:12	R/W	0x3	PF3_SELECT 000:Input                      001:Output 010:SDC0_CMD              011:JTAG_DO 100:Reserved                101:Reserved 110:Reserved                111:IO Disable
11	/	/	/
10:8	R/W	0x7	PF2_SELECT 000:Input                      001:Output 010:SDC0_CLK              011:UART0_TX 100:Reserved                101:Reserved



			110:Reserved	111:IO Disable
7	/	/	/	
6:4	R/W	0x3	PF1_SELECT 000:Input 010:SDCO_D0 100:Reserved 110:Reserved	001:Output 011:JTAG_DI 101:Reserved 111:IO Disable
3	/	/	/	
2:0	R/W	0x3	PF0_SELECT 000:Input 010:SDCO_D1 100:Reserved 110:Reserved	001:Output 011:JTAG_MS 101:Reserved 111:IO Disable

**4.22.2.38. PF Configure Register 1 (Default Value: 0x00000000)**

Offset: 0xB8			Register Name: <b>PF_CFG1_REG</b>
Bit	R/W	Default/Hex	Description
31:0	/	/	/

**4.22.2.39. PF Configure Register 2 (Default Value: 0x00000000)**

Offset: 0xBC			Register Name: <b>PF_CFG2_REG</b>
Bit	R/W	Default/Hex	Description
31:0	/	/	/

**4.22.2.40. PF Configure Register 3 (Default Value: 0x00000000)**

Offset: 0xC0			Register Name: <b>PF_CFG3_REG</b>
Bit	R/W	Default/Hex	Description
31:0	/	/	/

**4.22.2.41. PF Data Register (Default Value: 0x00000000)**

Offset: 0xC4			Register Name: <b>PF_DATA_REG</b>
Bit	R/W	Default/Hex	Description
31:7	/	/	/
6:0	R/W	0x0	PF_DAT If the port is configured as input, the corresponding bit is the pin state. If

			the port is configured as output, the pin state is the same as the corresponding bit. The read bit value is the value setup by software. If the port is configured as functional pin, the undefined value will be read.
--	--	--	---

**4.22.2.42. PF Multi-Driving Register 0 (Default Value: 0x00001555)**

Offset: 0xC8			Register Name: <b>PF_DRV0_REG</b>
Bit	R/W	Default/Hex	Description
31:14	/	/	/
[2i+1:2i] (i=0~6)	R/W	0x1	PF_DRV PF[n] Multi-Driving SELECT (n = 0~6) 00: Level 0                      01: Level 1 10: Level 2                      11: Level 3

**4.22.2.43. PF Multi-Driving Register 1 (Default Value: 0x00000000)**

Offset: 0xCC			Register Name: <b>PF_DRV1_REG</b>
Bit	R/W	Default/Hex	Description
31:0	/	/	/

**4.22.2.44. PF PULL Register 0 (Default Value: 0x00000000)**

Offset: 0xD0			Register Name: <b>PF_PULL0_REG</b>
Bit	R/W	Default/Hex	Description
31:14	/	/	/
[2i+1:2i] (i=0~6)	R/W	0x0	PF_PULL PF[n] Pull-up/down Select (n = 0~6) 00: Pull-up/down disable    01: Pull-up 10: Pull-down                    11: Reserved

**4.22.2.45. PF PULL Register 1 (Default Value: 0x00000000)**

Offset: 0xD4			Register Name: <b>PF_PULL1_REG</b>
Bit	R/W	Default/Hex	Description
31:0	/	/	/

**4.22.2.46. PG Configure Register 0 (Default Value: 0x77777777)**

Offset: 0xD8			Register Name: <b>PG_CFG0_REG</b>
Bit	R/W	Default/Hex	Description
31	/	/	/
30:28	R/W	0x7	PG7_SELECT 000:Input                    001:Output 010:UART1_RX                011: Reserved 100:Reserved                 101:Reserved 110:PG_EINT7                111:IO Disable
27	/	/	/
26:24	R/W	0x7	PG6_SELECT 000:Input                    001:Output 010:UART1_TX                011: Reserved 100:Reserved                 101:Reserved 110:PG_EINT6                111:IO Disable
23	/	/	/
22:20	R/W	0x7	PG5_SELECT 000:Input                    001:Output 010:SDC1_D3                 011:Reserved 100:Reserved                 101:Reserved 110:PG_EINT5                111:IO Disable
19	/	/	/
18:16	R/W	0x7	PG4_SELECT 000:Input                    001:Output 010:SDC1_D2                 011:Reserved 100:Reserved                 101:Reserved 110:PG_EINT4                111:IO Disable
15	/	/	/
14:12	R/W	0x7	PG3_SELECT 000:Input                    001:Output 010:SDC1_D1                 011:Reserved 100:Reserved                 101:Reserved 110:PG_EINT3                111:IO Disable
11	/	/	/
10:8	R/W	0x7	PG2_SELECT 000:Input                    001:Output 010:SDC1_D0                 011:Reserved 100:Reserved                 101:Reserved 110:PG_EINT2                111:IO Disable
7	/	/	/
6:4	R/W	0x7	PG1_SELECT 000:Input                    001:Output 010:SDC1_CMD                011:Reserved

			100:Reserved 110:PG_EINT1	101:Reserved 111:IO Disable
3	/	/	/	
2:0	R/W	0x7	PG0_SELECT 000:Input 010:SDC1_CLK 100:Reserved 110:PG_EINT0	001:Output 011:Reserved 101:Reserved 111:IO Disable

**4.22.2.47. PG Configure Register 1 (Default Value: 0x00777777)**

Offset: 0xDC			Register Name: <b>PG_CFG1_REG</b>	
Bit	R/W	Default/Hex	Description	
31:23	/	/	/	
22:20	R/W	0x7	PG13_SELECT 000:Input 010: PCM1_DIN 100:Reserved 110:PG_EINT13	001:Output 011: Reserved 101:Reserved 111:IO Disable
19	/	/	/	
18:16	R/W	0x7	PG12_SELECT 000:Input 010: PCM1_DOUT 100:Reserved 110:PG_EINT12	001:Output 011: Reserved 101:Reserved 111:IO Disable
15	/	/	/	
14:12	R/W	0x7	PG11_SELECT 000:Input 010: PCM1_CLK 100:Reserved 110:PG_EINT11	001:Output 011: Reserved 101:Reserved 111:IO Disable
11	/	/	/	
10:8	R/W	0x7	PG10_SELECT 000:Input 010: PCM1_CLK 100:Reserved 110:PG_EINT10	001:Output 011: Reserved 101:Reserved 111:IO Disable
7	/	/	/	
6:4	R/W	0x7	PG9_SELECT 000:Input 010:UART1_CTS 100:Reserved 110:PG_EINT9	001:Output 011: Reserved 101:Reserved 111:IO Disable
3	/	/	/	

2:0	R/W	0x7	PG8_SELECT 000:Input 010:UART1_RTS 100:Reserved 110:PG_EINT8	001:Output 011: Reserved 101:Reserved 111:IO Disable
-----	-----	-----	--	---

**4.22.2.48. PG Configure Register 2 (Default Value: 0x00000000)**

Offset: 0xE0			Register Name: <b>PG_CFG2_REG</b>
Bit	R/W	Default/Hex	Description
31:0	/	/	/

**4.22.2.49. PG Configure Register 3 (Default Value: 0x00000000)**

Offset: 0xE4			Register Name: <b>PG_CFG3_REG</b>
Bit	R/W	Default/Hex	Description
31:0	/	/	/

**4.22.2.50. PG Data Register (Default Value: 0x00000000)**

Offset: 0xE8			Register Name: <b>PG_DATA_REG</b>
Bit	R/W	Default/Hex	Description
31:14	/	/	/
13:0	R/W	0x0	PG_DAT If the port is configured as input, the corresponding bit is the pin state. If the port is configured as output, the pin state is the same as the corresponding bit. The read bit value is the value setup by software. If the port is configured as functional pin, the undefined value will be read.

**4.22.2.51. PG Multi-Driving Register 0 (Default Value: 0x05555555)**

Offset: 0xEC			Register Name: <b>PG_DRV0_REG</b>
Bit	R/W	Default/Hex	Description
31:28	/	/	/
[2i+1:2i] (i=0~13)	R/W	0x1	PF_DRV PF[n] Multi-Driving SELECT (n = 0~13) 00: Level 0 01: Level 1 10: Level 2 11: Level 3

**4.22.2.52. PG Multi-Driving Register 1 (Default Value: 0x00000000)**

Offset: 0xF0			Register Name: <b>PG_DRV1_REG</b>
Bit	R/W	Default/Hex	Description
31:0	/	/	/

**4.22.2.53. PG PULL Register 0 (Default Value: 0x00000000)**

Offset: 0xF4			Register Name: <b>PG_PULL0_REG</b>
Bit	R/W	Default/Hex	Description
31:28	/	/	/
[2i+1:2i] (i=0~13)	R/W	0x0	<b>PF_PULL</b> PF[n] Pull-up/down Select (n = 0~13) 00: Pull-up/down disable    01: Pull-up 10: Pull-down                    11: Reserved

**4.22.2.54. PG PULL Register 1 (Default Value: 0x00000000)**

Offset: 0xF8			Register Name: <b>PG_PULL1_REG</b>
Bit	R/W	Default/Hex	Description
31:0	/	/	/

**4.22.2.55. PA External Interrupt Configure Register 0 (Default Value: 0x00000000)**

Offset: 0x200			Register Name: <b>PA_EINT_CFG0_REG</b>
Bit	R/W	Default/Hex	Description
[4i+3:4i] (i=0~7)	R/W	0	<b>EINT_CFG</b> External INTn Mode (n = 0~7) 0x0: Positive Edge 0x1: Negative Edge 0x2: High Level 0x3: Low Level 0x4: Double Edge (Positive/ Negative) Others: Reserved

**4.22.2.56. PA External Interrupt Configure Register 1 (Default Value: 0x00000000)**

Offset: 0x204			Register Name: <b>PA_EINT_CFG1_REG</b>
Bit	R/W	Default/Hex	Description

[4i+3:4i] (i=0~7)	R/W	0	EINT_CFG External INTn Mode (n = 8~15) 0x0: Positive Edge 0x1: Negative Edge 0x2: High Level 0x3: Low Level 0x4: Double Edge (Positive/ Negative) Others: Reserved
----------------------	-----	---	---

**4.22.2.57. PA External Interrupt Configure Register 2 (Default Value: 0x00000000)**

Offset: 0x208			Register Name: PA_EINT_CFG2_REG
Bit	R/W	Default/Hex	Description
[4i+3:4i] (i=0~7)	R/W	0	EINT_CFG External INTn Mode (n = 16~21) 0x0: Positive Edge 0x1: Negative Edge 0x2: High Level 0x3: Low Level 0x4: Double Edge (Positive/ Negative) Others: Reserved

**4.22.2.58. PA External Interrupt Configure Register 3 (Default Value: 0x00000000)**

Offset: 0x20C			Register Name: PA_EINT_CFG3_REG
Bit	R/W	Default/Hex	Description
31:0	/	/	/

**4.22.2.59. PA External Interrupt Control Register (Default Value: 0x00000000)**

Offset: 0x210			Register Name: PA_EINT_CTL_REG
Bit	R/W	Default/Hex	Description
31:24	/	/	/
[n] (n=0~23)	R/W	0	EINT_CTL External INTn Enable (n = 0~21) 0: Disable 1: Enable

**4.22.2.60. PA External Interrupt Status Register (Default Value: 0x00000000)**

Offset: 0x214			Register Name: <b>PA_EINT_STATUS_REG</b>
Bit	R/W	Default/Hex	Description
31:24	/	/	/
[n] (n=0~23)	R/W	0	EINT_STATUS External INTn Pending Bit (n = 0~21) 0: No IRQ pending 1: IRQ pending Write '1' to clear

**4.22.2.61. PA External Interrupt Debounce Register (Default Value: 0x00000000)**

Offset: 0x218			Register Name: <b>PA_EINT_DEB_REG</b>
Bit	R/W	Default/Hex	Description
31:7	/	/	/
6:4	R/W	0	DEB_CLK_PRE_SCALE Debounce Clock Pre-scale n The selected clock source is prescaled by 2^n.
3:1	/	/	/
0	R/W	0	PIO_INT_CLK_SELECT PIO Interrupt Clock Select 0: LOSC 32Khz 1: HOSC 24Mhz

**4.22.2.62. PG External Interrupt Configure Register 0 (Default Value: 0x00000000)**

Offset: 0x220			Register Name: <b>PG_EINT_CFG0_REG</b>
Bit	R/W	Default/Hex	Description
31:12	/	/	/
[4i+3:4i] (i=0~7)	R/W	0	EINT_CFG External INTn Mode (n = 0~7) 0x0: Positive Edge 0x1: Negative Edge 0x2: High Level 0x3: Low Level 0x4: Double Edge (Positive/ Negative) Others: Reserved



**4.22.2.63. PG External Interrupt Configure Register 1 (Default Value: 0x00000000)**

Offset: 0x224			Register Name: <b>PG_EINT_CFG1_REG</b>
Bit	R/W	Default/Hex	Description
31:24	/	/	/
[4i+3:4i] (i=0~5)	R/W	0	EINT_CFG External INTn Mode (n = 8~13) 0x0: Positive Edge 0x1: Negative Edge 0x2: High Level 0x3: Low Level 0x4: Double Edge (Positive/ Negative) Others: Reserved

**4.22.2.64. PG External Interrupt Configure Register 2 (Default Value: 0x00000000)**

Offset: 0x228			Register Name: <b>PG_EINT_CFG2_REG</b>
Bit	R/W	Default/Hex	Description
31:0	/	/	/

**4.22.2.65. PG External Interrupt Configure Register 3 (Default Value: 0x00000000)**

Offset: 0x22C			Register Name: <b>PG_EINT_CFG3_REG</b>
Bit	R/W	Default/Hex	Description
31:0	/	/	/

**4.22.2.66. PG External Interrupt Control Register (Default Value: 0x00000000)**

Offset: 0x230			Register Name: <b>PG_EINT_CTL_REG</b>
Bit	R/W	Default/Hex	Description
31:14	/	/	/
[n] (n=0~13)	R/W	0	EINT_CTL External INTn Enable (n = 0~13) 0: Disable 1: Enable

**4.22.2.67. PG External Interrupt Status Register (Default Value: 0x00000000)**

Offset: 0x234			Register Name: <b>PG_EINT_STATUS_REG</b>
Bit	R/W	Default/Hex	Description

31:14	/	/	/
[n] (n=0~13)	R/W	0	<b>EINT_STATUS</b> External INTn Pending Bit (n = 0~13) 0: No IRQ pending 1: IRQ pending Write '1' to clear

**4.22.2.68. PG External Interrupt Debounce Register (Default Value: 0x00000000)**

Offset: 0x238			Register Name: <b>PG_EINT_DEB_REG</b>
Bit	R/W	Default/Hex	Description
31:7	/	/	/
6:4	R/W	0	<b>DEB_CLK_PRE_SCALE</b> Debounce Clock Pre-scale n The selected clock source is prescaled by 2^n.
3:1	/	/	/
0	R/W	0	<b>PIO_INT_CLK_SELECT</b> PIO Interrupt Clock Select 0: LOSC 32Khz 1: HOSC 24Mhz

Confidential

## 4.23. Port Controller(CPUs-PORT)

The chip has 1 port for multi-functional input/out pins. They are shown below:

- Port L(PL):12 input/output port

For various system configurations, these ports can be easily configured by software. All these ports can be configured as GPIO if multiplexed functions not used. The external PIO interrupt sources are supported and interrupt mode can be configured by software.

### 4.23.1. Port Controller Register List

Module Name	Base Address
PIO	0x01F02C00

Register Name	Offset	Description
PL_CFG0	0*0x24+0x00	Port L Configure Register 0
PL_CFG1	0*0x24+0x04	Port L Configure Register 1
PL_CFG2	0*0x24+0x08	Port L Configure Register 2
PL_CFG3	0*0x24+0x0C	Port L Configure Register 3
PL_DAT	0*0x24+0x10	Port L Data Register
PL_DRV0	0*0x24+0x14	Port L Multi-Driving Register 0
PL_DRV1	0*0x24+0x18	Port L Multi-Driving Register 1
PL_PUL0	0*0x24+0x1C	Port L Pull Register 0
PL_PUL1	0*0x24+0x20	Port L Pull Register 1
PL_INT_CFG0	0x200+0*0x20+0x00	PIO Interrupt Configure Register 0
PL_INT_CFG1	0x200+0*0x20+0x04	PIO Interrupt Configure Register 1
PL_INT_CFG2	0x200+0*0x20+0x08	PIO Interrupt Configure Register 2
PL_INT_CFG3	0x200+0*0x20+0x0C	PIO Interrupt Configure Register 3
PL_INT_CTL	0x200+0*0x20+0x10	PIO Interrupt Control Register
PL_INT_STA	0x200+0*0x20+0x14	PIO Interrupt Status Register
PL_INT_DEB	0x200+0*0x20+0x18	PIO Interrupt Debounce Register

### 4.23.2. Port Controller Register Description

#### 4.23.2.1. PL Configure Register 0 (Default Value: 0x77777777)

Offset: 0x00			Register Name: <b>PL_CFG0_REG</b>
Bit	R/W	Default/Hex	Description
31	/	/	/

30:28	R/W	0x7	PL7_SELECT 000:Input 010:S_JTAG_DI 100:Reserved 110:S_PL_EINT7	001:Output 011:Reserved 101:Reserved 111:IO Disable
27	/	/	/	/
26:24	R/W	0x7	PL6_SELECT 000:Input 010:S_JTAG_DO 100:Reserved 110:S_PL_EINT6	001:Output 011:Reserved 101:Reserved 111:IO Disable
23	/	/	/	/
22:20	R/W	0x7	PL5_SELECT 000:Input 010:S_JTAG_CK 100:Reserved 110:S_PL_EINT5	001:Output 011:Reserved 101:Reserved 111:IO Disable
19	/	/	/	/
18:16	R/W	0x7	PL4_SELECT 000:Input 010:S_JTAG_MS 100:Reserved 110:S_PL_EINT4	001:Output 011:Reserved 101:Reserved 111:IO Disable
15	/	/	/	/
14:12	R/W	0x7	PL3_SELECT 000:Input 010:S_UART_RX 100:Reserved 110:S_PL_EINT3	001:Output 011:Reserved 101:Reserved 111:IO Disable
11	/	/	/	/
10:8	R/W	0x7	PL2_SELECT 000:Input 010:S_UART_TX 100:Reserved 110:S_PL_EINT2	001:Output 011:Reserved 101:Reserved 111:IO Disable
7	/	/	/	/
6:4	R/W	0x7	PL1_SELECT 000:Input 010:S_TWI_SDA 100:Reserved 110:S_PL_EINT1	001:Output 011:Reserved 101:Reserved 111:IO Disable
3	/	/	/	/
2:0	R/W	0x7	PL0_SELECT 000:Input 010:S_TWI_SCK	001:Output 011:Reserved

			100:Reserved 110:S_PL_EINT0	101:Reserved 111:IO Disable
--	--	--	--------------------------------	--------------------------------

**4.23.2.2. PL Configure Register 1 (Default Value: 0x00007777)**

Offset: 0x04			Register Name: PL_CFG1_REG
Bit	R/W	Default/Hex	Description
31:15	/	/	/
14:12	R/W	0x7	PL11_SELECT 000:Input                      001:Output 010:S_CIR_RX                      011:Reserved 100:Reserved                      101:Reserved 110:S_PL_EINT11                      111:IO Disable
11	/	/	/
10:8	R/W	0x7	PL10_SELECT 000:Input                      001:Output 010:S_PWM                      011:Reserved 100:Reserved                      101:Reserved 110:S_PL_EINT10                      111:IO Disable
7	/	/	/
6:4	R/W	0x7	PL9_SELECT 000:Input                      001:Output 010:Reserved                      011:Reserved 100:Reserved                      101:Reserved 110:S_PL_EINT9                      111:IO Disable
3	/	/	/
2:0	R/W	0x7	PL8_SELECT 000:Input                      001:Output 010:Reserved                      011:Reserved 100:Reserved                      101:Reserved 110:S_PL_EINT8                      111:IO Disable

**4.23.2.3. PL Configure Register 2 (Default Value: 0x00000000)**

Offset: 0x08			Register Name: PL_CFG2_REG
Bit	R/W	Default/Hex	Description
31:0	/	/	/

**4.23.2.4. PL Configure Register 3 (Default Value: 0x00000000)**

Offset: 0x0C			Register Name: PL_CFG3_REG
Bit	R/W	Default/Hex	Description

31:0	/	/	/
------	---	---	---

**4.23.2.5. PL Data Register (Default Value: 0x00000000)**

Offset: 0x10			Register Name: <b>PL_DATA_REG</b>
Bit	R/W	Default/Hex	Description
31:12	/	/	/
11:0	R/W	0	<b>PL_DAT</b> If the port is configured as input, the corresponding bit is the pin state. If the port is configured as output, the pin state is the same as the corresponding bit. The read bit value is the value setup by software. If the port is configured as functional pin, the undefined value will be read.

**4.23.2.6. PL Multi-Driving Register 0 (Default Value: 0x00555555)**

Offset: 0x14			Register Name: <b>PL_DRV0</b>
Bit	R/W	Default/Hex	Description
31:24	/	/	/
$[2i+1:2i]$ $(i=0\sim11)$	R/W	0x1	<b>PL_DRV</b> PL[n] Multi-Driving Select (n = 0~11) 00: Level 0                      01: Level 1 10: Level 2                     11: Level 3

**4.23.2.7. PL Multi-Driving Register 1 (Default Value: 0x00000000)**

Offset: 0x18			Register Name: <b>PL_DRV1</b>
Bit	R/W	Default/Hex	Description
31:0	/	/	/

**4.23.2.8. PL PULL Register 0 (Default Value: 0x00000005)**

Offset: 0x1C			Register Name: <b>PL_PULL0</b>
Bit	R/W	Default/Hex	Description
31:24	/	/	/
$[2i+1:2i]$ $(i=0\sim11)$	R/W	0x5	<b>PL_PULL</b> PL[n] Pull-up/down Select (n = 0~11) 00: Pull-up/down disable    01: Pull-up 10: Pull-down                    11: Reserved

**4.23.2.9. PL PULL Register 1 (Default Value: 0x00000000)**

Offset: 0x20			Register Name: <b>PL_PULL1</b>
Bit	R/W	Default/Hex	Description
31:0	/	/	/

**4.23.2.10. PL External Interrupt Configure Register 0 (Default Value: 0x00000000)**

Offset: 0x200			Register Name: <b>PL_EINT_CFG0</b>
Bit	R/W	Default/Hex	Description
[4i+3:4i] (i=0~7)	R/W	0	EINT_CFG External INTn Mode (n = 0~7) 0x0: Positive Edge 0x1: Negative Edge 0x2: High Level 0x3: Low Level 0x4: Double Edge (Positive/ Negative) Others: Reserved

**4.23.2.11. PL External Interrupt Configure Register 1 (Default Value: 0x00000000)**

Offset: 0x204			Register Name: <b>PL_EINT_CFG1</b>
Bit	R/W	Default/Hex	Description
31:20	/	/	/
[4i+3:4i] (i=0~4)	R/W	0	EINT_CFG External INTn Mode (n = 8~11) 0x0: Positive Edge 0x1: Negative Edge 0x2: High Level 0x3: Low Level 0x4: Double Edge (Positive/ Negative) Others: Reserved

**4.23.2.12. PL External Interrupt Configure Register 2 (Default Value: 0x00000000)**

Offset: 0x208			Register Name: <b>PL_EINT_CFG2</b>
Bit	R/W	Default/Hex	Description
31:0	/	/	/

**4.23.2.13. PL External Interrupt Configure Register 3 (Default Value: 0x00000000)**

Offset: 0x20C			Register Name: <b>PL_EINT_CFG3</b>
Bit	R/W	Default/Hex	Description
31:0	/	/	/

**4.23.2.14. PL External Interrupt Control Register (Default Value: 0x00000000)**

Offset: 0x210			Register Name: <b>PL_EINT_CTL</b>
Bit	R/W	Default/Hex	Description
31:12	/	/	/
[n] (n=0~11)	R/W	0	EINT_CTL External INTn Enable (n = 0~11) 0: Disable 1: Enable

**4.23.2.15. PL External Interrupt Status Register (Default Value: 0x00000000)**

Offset: 0x214			Register Name: <b>PL_EINT_STATUS</b>
Bit	R/W	Default/Hex	Description
31:12	/	/	/
[n] (n=0~11)	R/W	0	EINT_STATUS External INTn Pending Bit (n = 0~11) 0: No IRQ pending 1: IRQ pending Write '1' to clear

**4.23.2.16. PL External Interrupt Debounce Register (Default Value: 0x00000000)**

Offset: 0x218			Register Name: <b>PL_EINT_DEB</b>
Bit	R/W	Default/Hex	Description
31:7	/	/	/
6:4	R/W	0	DEB_CLK_PRE_SCALE Debounce Clock Pre-scale n The selected clock source is prescaled by 2^n.
3:1	/	/	/
0	R/W	0	PIO_INT_CLK_SELECT PIO Interrupt Clock Select 0: LOSC 32KHz 1: HOSC 24MHz



# Chapter 5 Memory

This section describes the H3 memory from three aspects:

- SDRAM
- NAND Flash
- SD/MMC

## 5.1. SDRAM

### 5.1.1. Overview

The SDRAM Controller (DRAMC) provides a simple, flexible, burst-optimized interface to all industry-standard SDRAM. It supports up to a 16G bits memory address space.

The DRAMC automatically handles memory management, initialization, and refresh operations. It gives the host CPU a simple command interface, hiding details of the required address, page, and burst handling procedures. All memory parameters are runtime-configurable, including timing, memory setting, SDRAM type, and Extended-Mode-Register settings. To simplify chip system integration, DDR controller works in half rate mode.

The DRAMC includes the following features:

- Support 32-bits one channel
- Support 2 Chip Select
- Support DDR2/DDR3/DDR3L/LPDDR2/LPDDR3 SDRAM
- Support Different Memory Device's Power Voltage of 1.2V 1.35V 1.5V and 1.8V
- Support clock frequency up to 667 MHz(DDR3-1333)
- Support Memory Capacity up to 16G bits (2G Bytes)
- Support 16 address lines and three bank address lines per channel
- Automatically generates initialization and refresh sequences
- Runtime-configurable parameters setting for application flexibility
- Priority of transferring through multiple ports is programmable
- Random read or write operation is supported

## 5.2. NAND Flash

### 5.2.1. Overview

The NDFC is the NAND Flash Controller which supports all NAND flash memory available in the market. New type flash can be supported by software re-configuration.

The On-the-fly error correction code (ECC) is built-in NDFC for enhancing reliability. BCH is implemented and it can detect and correct up to 64 bits error per 512 or 1024 bytes data. The on chip ECC and parity checking circuitry of NDFC frees CPU for other tasks. The ECC function can be disabled by software.

The data can be transferred by DMA or by CPU memory-mapped IO method. The NDFC provides automatic timing control for reading or writing external Flash. The NDFC maintains the proper relativity for CLE, CE# and ALE control signal lines. Three modes are supported for serial read access. The conventional serial access is mode 0 and mode 1 is for EDO type and mode 2 for extension EDO type. NDFC can monitor the status of R/B# signal line.

Block management and wear leveling management are implemented in software.

The NAND Flash Controller (NDFC) includes the following features:

- Supports all SLC/MLC/TLC flash and EF-NAND memory available in the market
- Software configure seed for randomize engine
- Software configure method for adaptability to a variety of system and memory types
- Supports 8-bit Data Bus Width
- Supports 1024, 2048, 4096, 8192, 16384 bytes size per page
- Supports Conventional and EDO serial access method for serial reading Flash
- On-the-fly BCH error correction code which correcting up to 64 bits per 512 or 1024 bytes
- Corrected Error bits number information report
- ECC automatic disable function for all 0xff data
- NDFC status information is reported by its' registers and interrupt is supported
- One Command FIFO
- External DMA is supported for transferring data
- Two 256x32-bit RAM for Pipeline Procession
- Support SDR, ONFI DDR and Toggle DDR NAND
- Support self-debug for NDFC debug

### 5.2.2. Block Diagram

The NAND Flash Controller (NDFC) system block diagram is shown below:

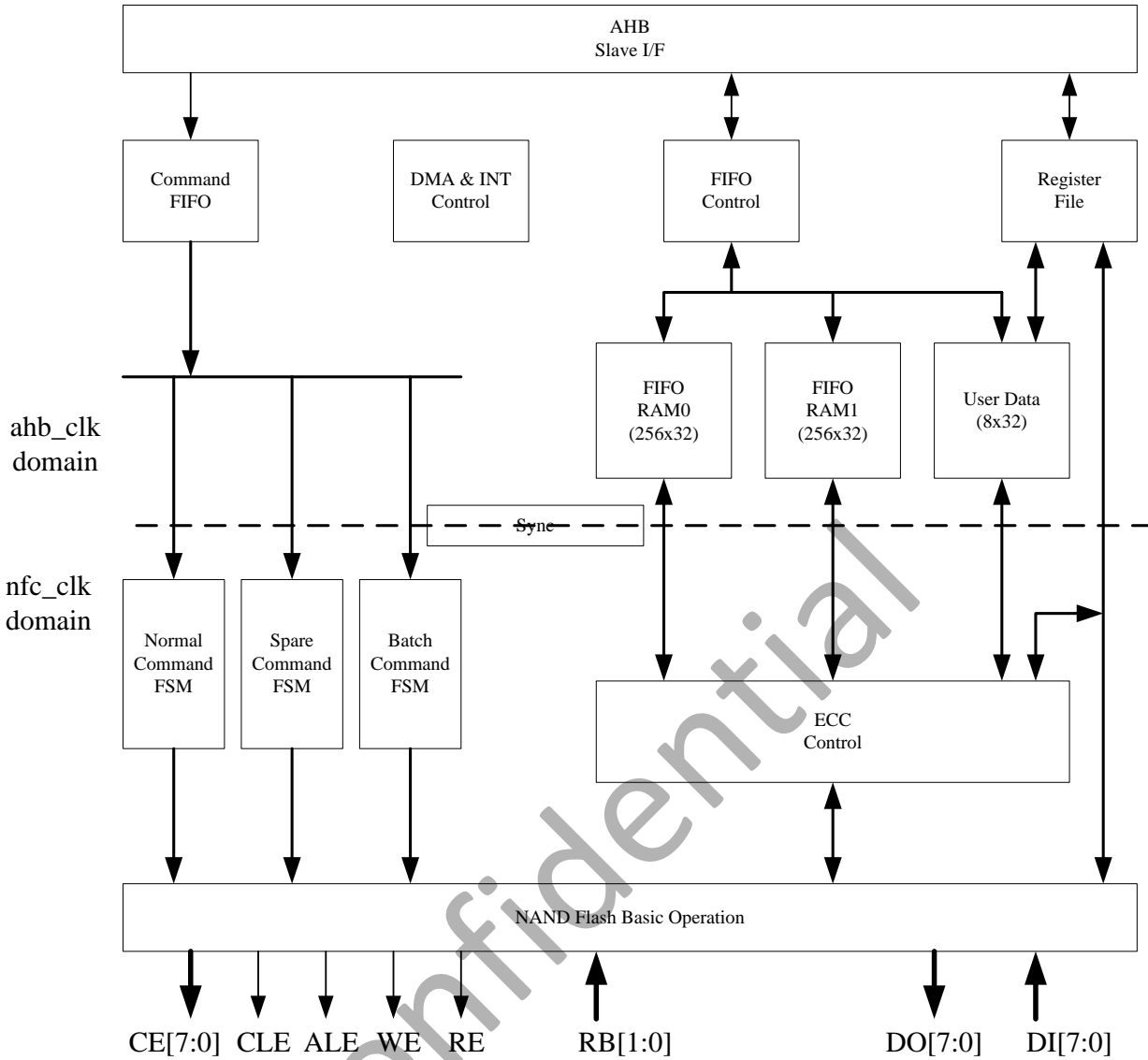

Figure 5-1. NDFC Block Diagram

### 5.2.3. NDFC Timing Diagram

Typically, there are two kinds of serial access method. One method is conventional method which fetching data at the rise edge of NDFC\_RE# signal line. Another one is EDO type which fetching data at the next fall edge of NDFC\_RE# signal line.

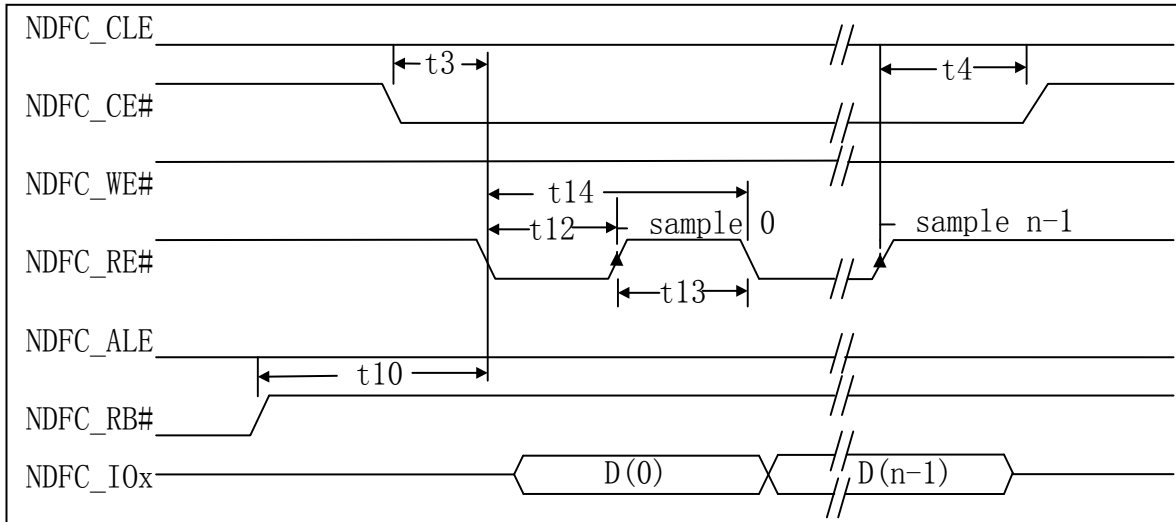

Figure 5-2. Conventional Serial Access Cycle Diagram (SAM0)

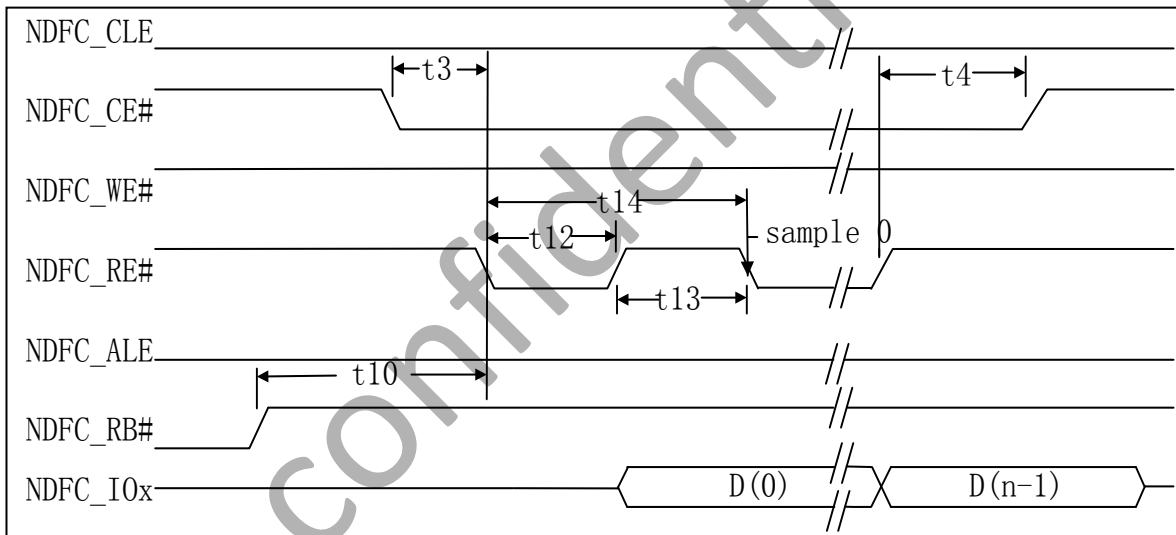

Figure 5-3. EDO type Serial Access after Read Cycle (SAM1)

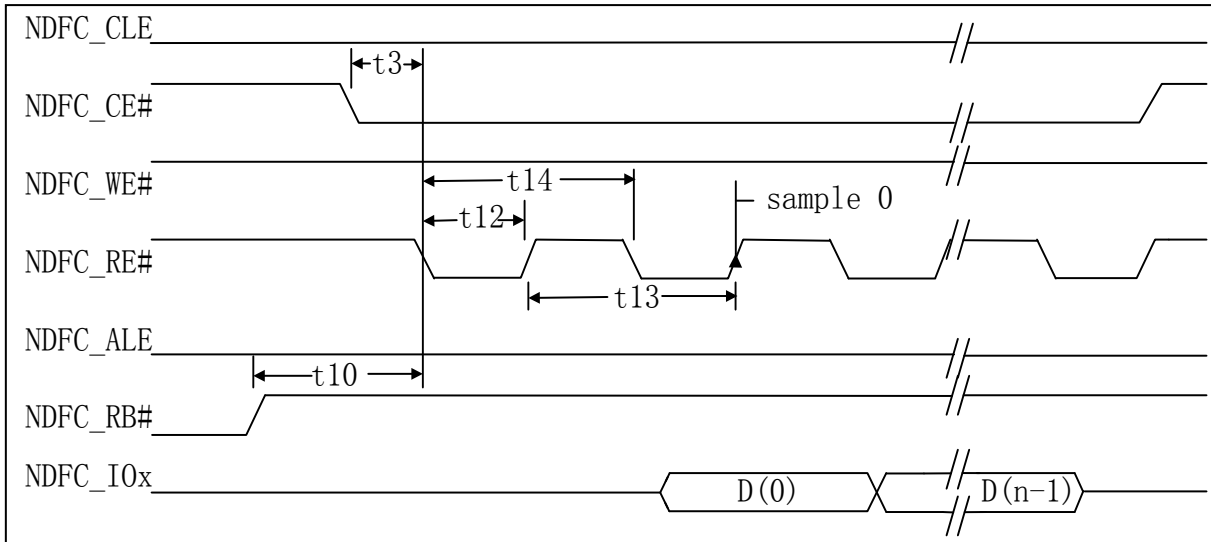

Figure 5-4. Extending EDO type Serial Access Mode (SAM2)

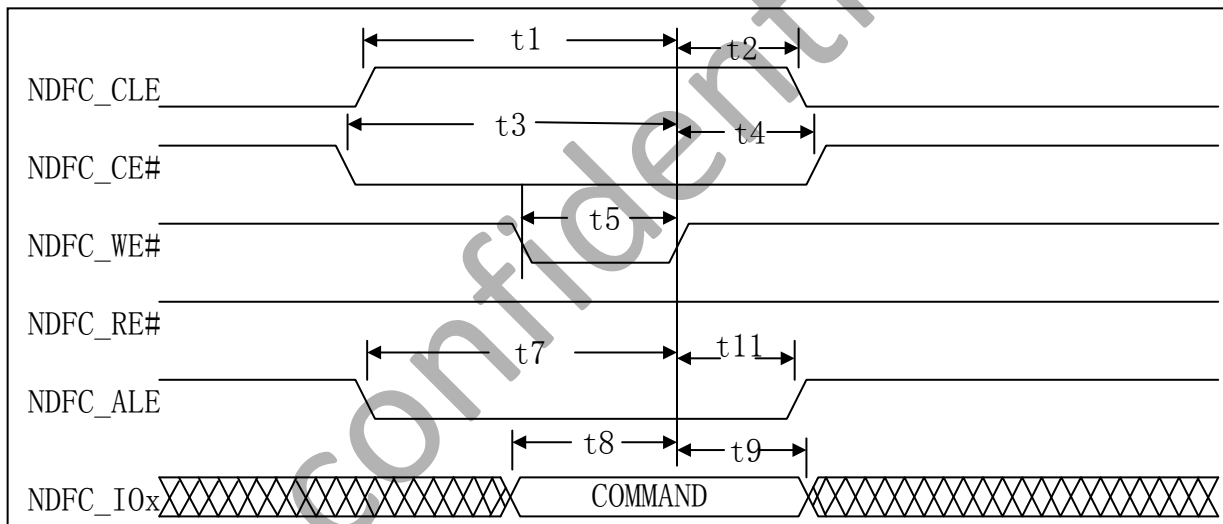

Figure 5-5. Command Latch Cycle

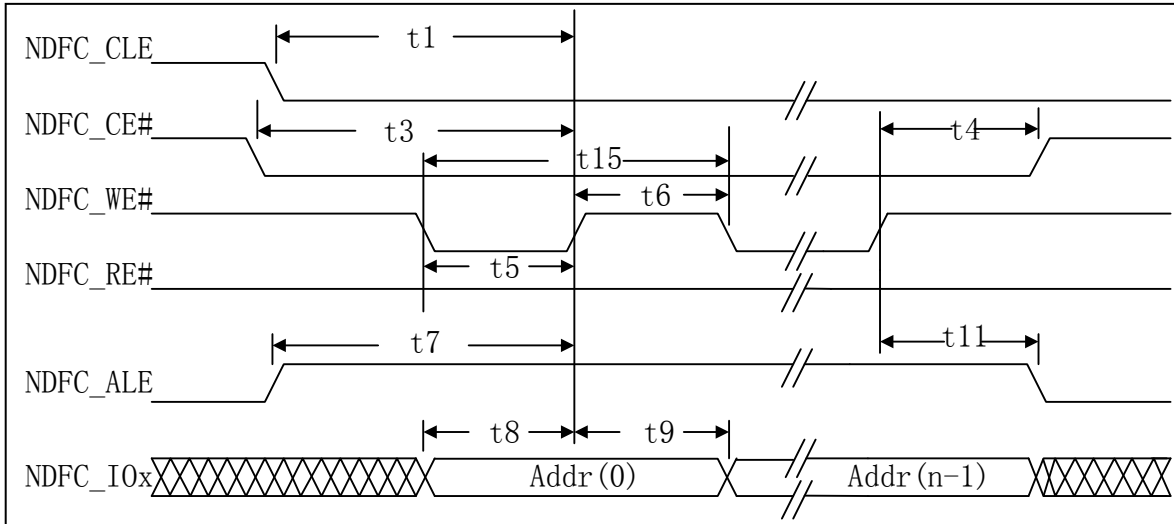

Figure 5-6. Address Latch Cycle

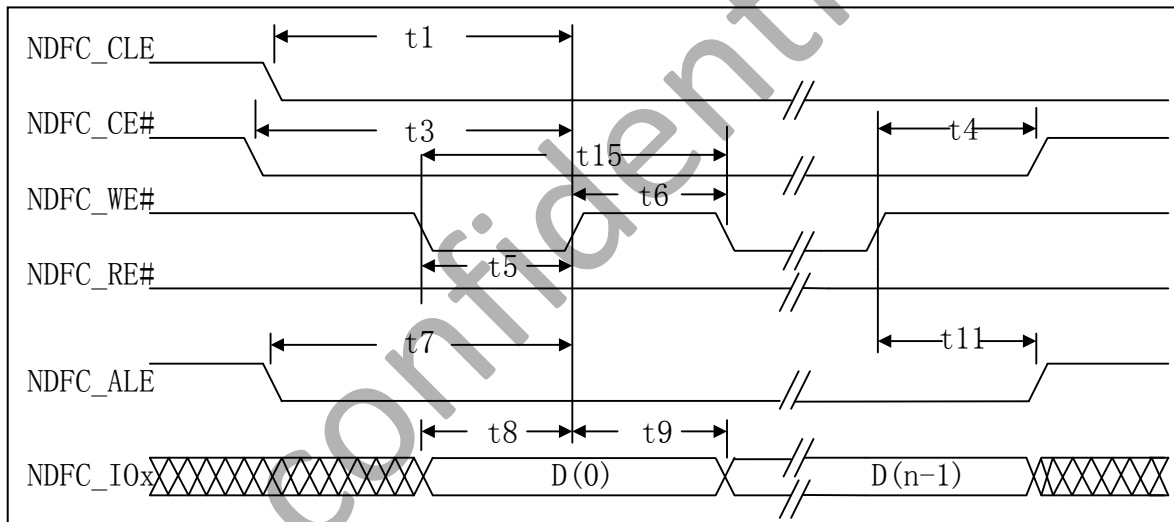

Figure 5-7. Write Data to Flash Cycle

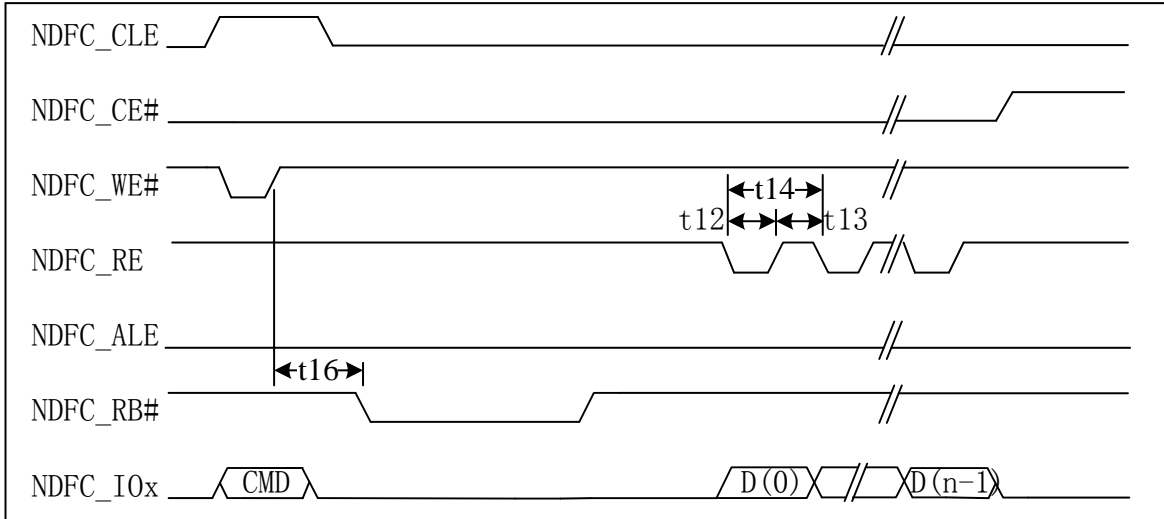

Figure 5-8. Waiting R/B# ready Diagram

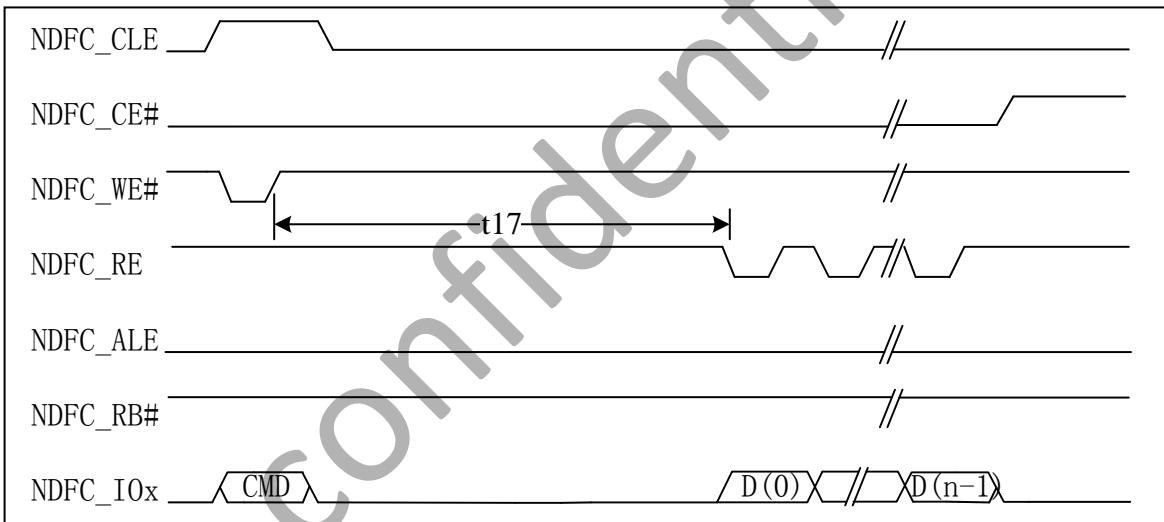

Figure 5-9. WE# high to RE# low Timing Diagram

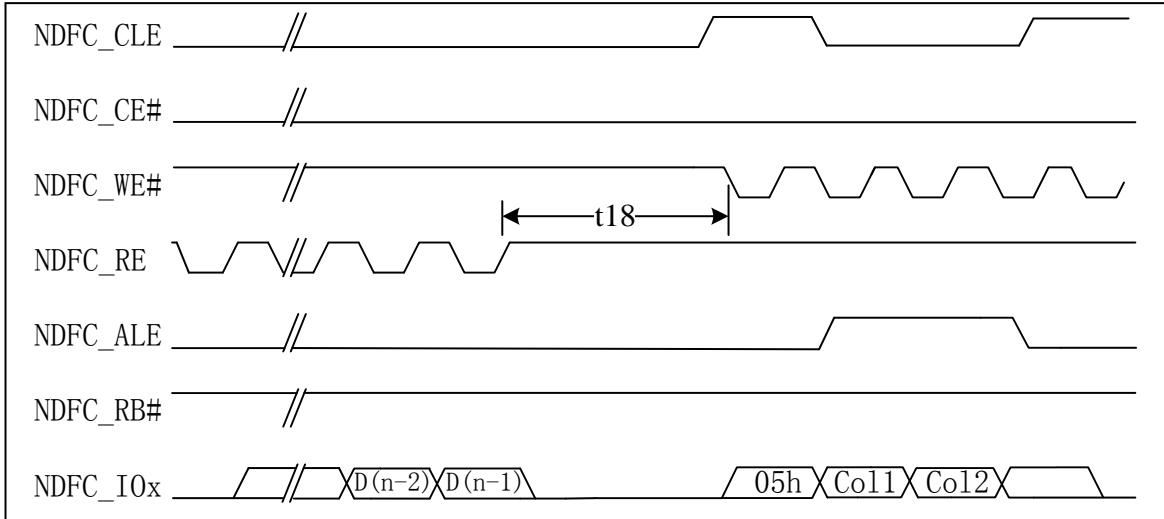

Figure 5-10. RE# high to WE# low Timing Diagram

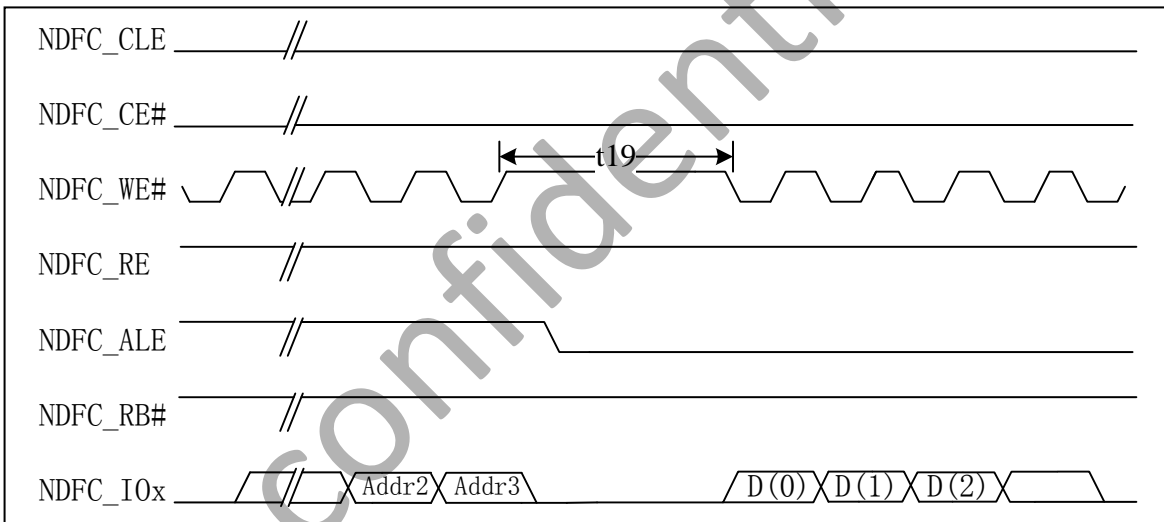

Figure 5-11. Address to Data Loading Timing Diagram

**Timing cycle list:**



ID	Parameter	Timing	Notes
t1	NDFC_CLE setup time	2T	
t2	NDFC_CLE hold time	2T	
t3	NDFC_CE setup time	2T	
t4	NDFC_CE hold time	2T	
t5	NDFC_WE# pulse width	T	
t6	NDFC_WE# hold time	T	
t7	NDFC_ALE setup time	2T	
t8	Data setup time	T	
t9	Data hold time	T	
t10	Ready to NDFC_RE# low	3T	
t11	NDFC_ALE hold time	2T	
t12	NDFC_RE# pulse width	T	
t13	NDFC_RE# hold time	T	
t14	Read cycle time	2T	
t15	Write cycle time	2T	
t16	NDFC_WE# high to R/B# busy	T_WB	Specified by timing configure register (NDFC_TIMING_CFG)
t17	NDFC_WE# high to NDFC_RE# low	T_WHR	Specified by timing configure register (NDFC_TIMING_CFG)
t18	NDFC_RE# high to NDFC_WE# low	T_RHW	Specified by timing configure register (NDFC_TIMING_CFG)
t19	Address to Data Loading time	T_ADL	Specified by timing configure register (NDFC_TIMING_CFG)

**Notes:** T is the clock period duration of NDFC\_CLK (x2).

5.2.4. NDFC Operation Guide

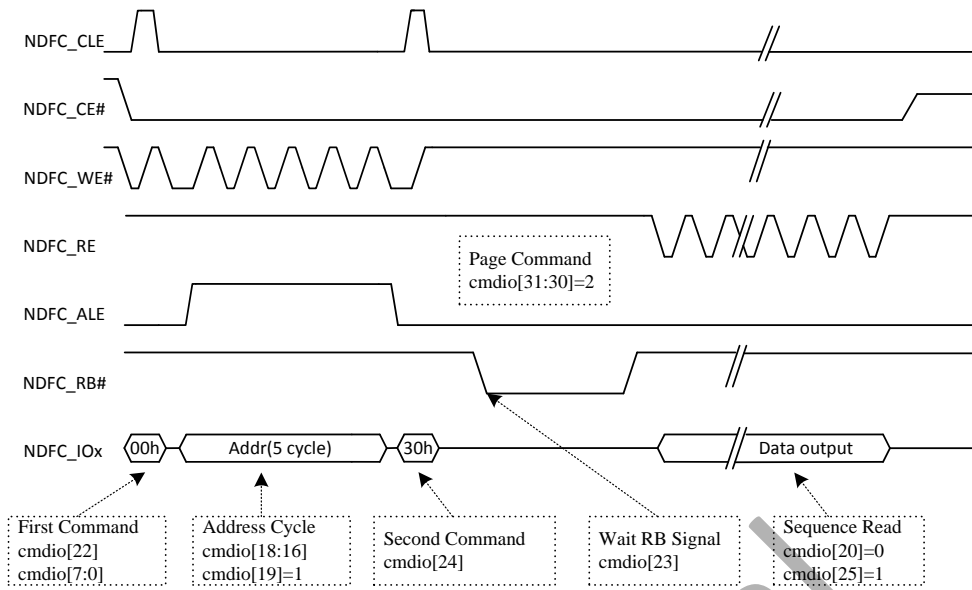

Figure 5-12. Page Read Command Diagram

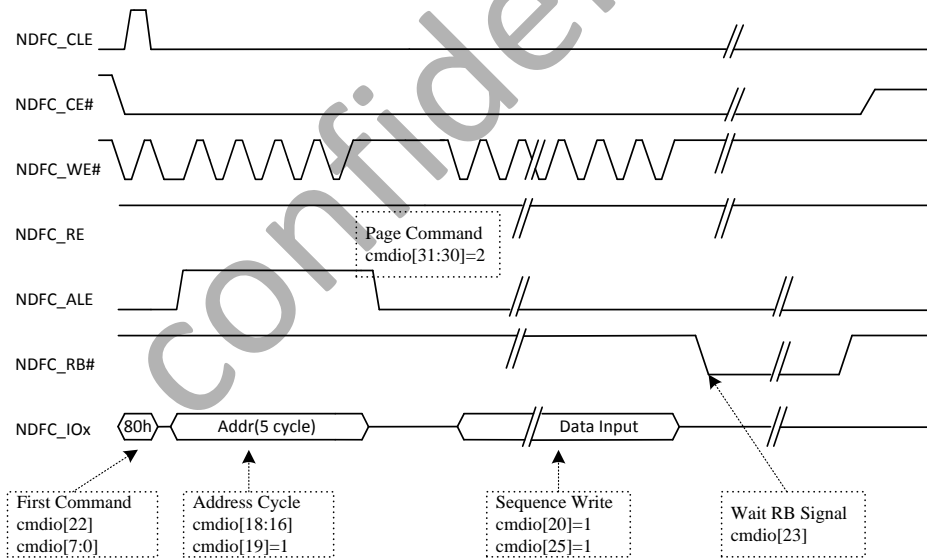

Figure 5-13. Page Program Diagram



NDFC_TIMING_CFG	0x10	NDFC Timing Configure Register
NDFC_ADDR_LOW	0x14	NDFC Low Word Address Register
NDFC_ADDR_HIGH	0x18	NDFC High Word Address Register
NDFC_BLOCK_NUM	0x1C	NDFC Data Block Number Register
NDFC_CNT	0x20	NDFC Data Counter for data transfer Register
NDFC_CMD	0x24	Set up NDFC commands Register
NDFC_RCMD_SET	0x28	Read Command Set Register for vendor's NAND memory
NDFC_WCMD_SET	0x2C	Write Command Set Register for vendor's NAND memory
NDFC_ECC_CTL	0x34	ECC Configure and Control Register
NDFC_ECC_ST	0x38	ECC Status and Operation information Register
NDFC_EFR	0x3C	Enhanced Feature Register
NDFC_ERR_CNT0	0x40	Corrected Error Bit Counter Register 0
NDFC_ERR_CNT1	0x44	Corrected Error Bit Counter Register 1
NDFC_USER_DATAn	0x50+4*n	User Data Field Register n (n from 0 to 15)
NDFC_EFNAND_STA	0x90	EFNAND Status Register
NDFC_SPARE_AREA	0xA0	Spare Area Configure Register
NDFC_PAT_ID	0xA4	Pattern ID Register
NDFC_RDATA_STA_CTL	0xA8	Read Data Status Control Register
NDFC_RDATA_STA_0	0xAC	Read Data Status Register 0
NDFC_RDATA_STA_1	0xB0	Read Data Status Register 1
NDFC_MDMA_ADDR	0xC0	MBUS DMA Address Register
NDFC_MDMA_CNT	0xC4	MBUS DMA Data Counter Register
NDFC_IO_DATA	0x300	Data Input/ Output Port Address Register
RAM0_BASE	0x400	1024 Bytes RAM0 base
RAM1_BASE	0x800	1024 Bytes RAM1 base

### 5.2.6. NDFC Register Description

#### 5.2.6.1. NDFC Control Register(Default Value: 0x00000000)

Offset: 0x00			Register Name: NDFC_CTL
Bit	R/W	Default/Hex	Description
31:28	/	/	/
27:24	R/W	0	NDFC_CE_SEL Chip Select for 8 NAND Flash Chips 0 -7: NDFC Chip Select Signal 0-7 is selected 8-15: NDFC CS[7:0] not selected. GPIO pins can be used for CS. NDFC can support up to 16 CS.
23:22	/	/	/
21	R/W	0	NDFC_DDR_RM

			DDR Repeat data mode 0: Lower byte 1: Higher byte
20	R/W	0	NDFC_DDR_REN DDR Repeat Enable 0: Disable 1: Enable
19:18	R/W	0	NF_TYPE NAND Flash Type 0x0: Normal SDR NAND 0x1: Reserved 0x2: ONFI DDR NAND 0x3: Toggle DDR NAND
17	R/W	0	NDFC_CLE_POL NDFC Command Latch Enable (CLE) Signal Polarity Select 0: High active 1: Low active
16	R/W	0	NDFC_ALE_POL NDFC Address Latch Enable (ALE) Signal Polarity Select 0: High active 1: Low active
15	R/W	0	NDFC_DMA_TYPE 0: Dedicated DMA 1: Normal DMA
14	R/W	0	NDFC_RAM_METHOD Access internal RAM method 0: Access internal RAM by AHB bus 1: Access internal RAM by DMA bus
13:12	/	/	/
11:8	R/W	0x0	NDFC_PAGE_SIZE 0x0: 1024 bytes 0x1: 2048 bytes 0x2: 4096 bytes 0x3: 8192 bytes 0x4: 16384 bytes Notes: The page size is for main field data.
7	/	/	/
6	R/W	0	NDFC_CE_ACT Chip Select Signal CE# Control During NAND operation 0: De-active Chip Select Signal NDFC_CE# during data loading, serial access and other no operation stage for power consumption. NDFC automatic control Chip Select Signals. 1: Chip select signal NDFC_CE# is always active after NDFC is enabled
5	/	/	/
4:3	R/W	0	NDFC_RB_SEL

			NDFC external R/B Signal select The value 0-3 selects the external R/B signal. The same R/B signal can be used for multiple chip select flash.
2	R/W	0	NDFC_BUS_WIDTH 0: 8-bit bus 1: 16-bit bus
1	R/W	0	NDFC_RESET NDFC Reset Write 1 to reset NDFC and clear to 0 after reset
0	R/W	0	NDFC_EN NDFC Enable Control 0: Disable NDFC 1: Enable NDFC

### 5.2.6.2. NDFC Status Register(Default Value: 0x00000000)

Offset: 0x04			Register Name: <b>NDFC_ST</b>
Bit	R/W	Default/Hex	Description
31:14	/	/	/
13	R	/	NDFC_RDATA_STA_0 0: The number of bit 1 during current read operation is greater threshold value. 1: The number of bit 1 during current read operation is less than or equal to threshold value. This field only is valid when NDFC_RDATA_STA_EN is 1. The threshold value is configured in NDFC_RDATA_STA_TH.
12	R	/	NDFC_RDATA_STA_1 0: The number of bit 0 during current read operation is greater threshold value. 1: The number of bit 0 during current read operation is less than or equal to than threshold value. This field only is valid when NDFC_RDATA_STA_EN is 1. The threshold value is configured in NDFC_RDATA_STA_TH.
11	R	/	NDFC_RB_STATE3 NAND Flash R/B 3 Line State 0: NAND Flash in BUSY State 1: NAND Flash in READY State
10	R	/	NDFC_RB_STATE2 NAND Flash R/B 2 Line State 0: NAND Flash in BUSY State 1: NAND Flash in READY State
9	R	/	NDFC_RB_STATE1 NAND Flash R/B 1 Line State 0: NAND Flash in BUSY State

			1: NAND Flash in READY State
8	R	/	NDFC_RB_STATE0 NAND Flash R/B 0 Line State 0: NAND Flash in BUSY State 1: NAND Flash in READY State
7:5	/	/	/
4	R	0	NDFC_STA 0: NDFC FSM in IDLE state 1: NDFC FSM in BUSY state When NDFC_STA is 0, NDFC can accept new command and process command.
3	R	0	NDFC_CMD_FIFO_STATUS 0: Command FIFO not full and can receive new command 1: Full and waiting NDFC to process commands in FIFO Since there is only one 32-bit FIFO for command. When NDFC latches one command, command FIFO is free and can accept another new command.
2	R/W	0	NDFC_DMA_INT_FLAG When it is 1, it means that a pending DMA is completed. It will be clear after writing 1 to this bit or it will be automatically clear before FSM processing an new command.
1	R/W	0	NDFC_CMD_INT_FLAG When it is 1, it means that NDFC has finished one Normal Command Mode or one Batch Command Work Mode. It will be clear after writing 1 to this bit or it will be automatically clear before FSM processing an new command.
0	R/W	0	NDFC_RB_B2R When it is 1, it means that NDFC_R/B# signal is transferred from BUSY state to READY state. It will be clear after writing 1 to this bit.

### 5.2.6.3. NDFC Interrupt and DMA Enable Register(Default Value: 0x00000000)

Offset: 0x08			Register Name: <b>NDFC_INT</b>
Bit	R/W	Default/Hex	Description
31:3	/	/	/
2	R/W	0	NDFC_DMA_INT_ENABLE Enable or disable interrupt when a pending DMA is completed.
1	R/W	0	NDFC_CMD_INT_ENABLE Enable or disable interrupt when NDFC has finished the procession of a single command in Normal Command Work Mode or one Batch Command Work Mode. 0: Disable 1: Enable
0	R/W	0	NDFC_B2R_INT_ENABLE Enable or disable interrupt when NDFC_RB# signal is transferring from BUSY state to READY state

		0: Disable 1: Enable
--	--	-------------------------

**5.2.6.4. NDFC Timing Control Register(Default Value: 0x00000000)**

Offset: 0x0C			Register Name: <b>NDFC_TIMING_CTL</b>
Bit	R/W	Default/Hex	Description
31:12	/	/	/
11:8	R/W	0x0	NDFC_READ_PIPE In SDR mode: 0: Normal 1: EDO 2: E-EDO Other : Reserved In DDR mode: 1~15 is valid.(These bits configure the number of clock when data is valid after RE#'s falling edge)
7:6	/	/	/
5:0	R/W	0x0	NDFC_DC_CTL NDFC Delay Chain Control. (These bits are only valid in DDR data interface, and configure the relative phase between DQS and DQ[0...7] )

**5.2.6.5. NDFC Timing Configure Register(Default Value: 0x00000095)**

Offset: 0x10			Register Name: <b>NDFC_TIMING_CFG</b>
Bit	R/W	Default/Hex	Description
31:20	/	/	/
19:18	R/W	0	T_WC Write Cycle Time 0: 1*2T 1: 2*2T 2: 3*2T 3: 4*2T
17:16	R/W	0	T_CCS Change Column Setup Time 0: 16*2T 1: 24*2T 2: 32*2T 3: 64*2T
15:14	R/W	0	T_CLHZ CLE High to Output Hi-z 0: 2*2T



			1: 8*2T 2: 16*2T 3: 31*2T
13:12	R/W	0	T_CS CE Setup Time 0: 2*2T 1: 8*2T 2: 16*2T 3: 31*2T
11			T_CDQSS DQS Setup Time for data input start 0: 8*2T 1: 24*2T
10:8	R/W	0	T_CAD Command, Address, Data Delay 000: 4*2T 001: 8*2T 010: 12*2T 011: 16*2T 100: 24*2T 101: 32*2T 110/111: 64*2T
7:6	R/W	0x2	T_RHW RE# high to WE# low cycle number 00: 4*2T 01: 8*2T 10: 12*2T 11: 20*2T
5:4	R/W	0x1	T_WHR WE# high to RE# low cycle number 00: 8*2T 01: 16*2T 10: 24*2T 11: 32*2T
3:2	R/W	0x1	T_ADL Address to Data Loading cycle number 00: 0*2T 01: 8*2T 10: 16*2T 11: 24*2T
1:0	R/W	0x1	T_WB WE# high to busy cycle number 00:14*2T 01:22*2T 10: 30*2T

			11:38*2T
--	--	--	----------

**5.2.6.6. NDFC Address Low Word Register(Default Value: 0x00000000)**

Offset: 0x14			Register Name: <b>NDFC_ADDR_LOW</b>
Bit	R/W	Default/Hex	Description
31:24	R/W	0	ADDR_DATA4 NAND Flash 4th Cycle Address Data
23:16	R/W	0	ADDR_DATA3 NAND Flash 3rd Cycle Address Data
15:8	R/W	0	ADDR_DATA2 NAND Flash 2nd Cycle Address Data
7:0	R/W	0	ADDR_DATA1 NAND Flash 1st Cycle Address Data

**5.2.6.7. NDFC Address High Word Register(Default Value: 0x00000000)**

Offset: 0x18			Register Name: <b>NDFC_ADDR_HIGH</b>
Bit	R/W	Default/Hex	Description
31:24	R/W	0	ADDR_DATA8 NAND Flash 8th Cycle Address Data
23:16	R/W	0	ADDR_DATA7 NAND Flash 7th Cycle Address Data
15:8	R/W	0	ADDR_DATA6 NAND Flash 6th Cycle Address Data
7:0	R/W	0	ADDR_DATA5 NAND Flash 5th Cycle Address Data

**5.2.6.8. NDFC Data Block Number Register(Default Value: 0x00000000)**

Offset: 0x1C			Register Name: <b>NDFC_DATA_BLOCK_NUM</b>
Bit	R/W	Default/Hex	Description
31:6	/	/	/
4:0	R/W	0	NDFC_DATA_BLOCK_NUM DATA BLOCK Number It is used for batch command procession. 0: no data 1: 1 data blocks 2: 2 data blocks ... 16: 16 data blocks

			Others: Reserved Notes: 1 data block = 512 or 1024 bytes main field data
--	--	--	---

**5.2.6.9. NDFC Data Counter Register(Default Value: 0x00000000)**

Offset: 0x20			Register Name: <b>NDFC_CNT</b>
Bit	R/W	Default/Hex	Description
31:10	/	/	/
9:0	R/W	0	NDFC_DATA_CNT Transfer Data Byte Counter The length can be set from 1 byte to 1024 bytes. However, 1024 bytes is set when it is zero.

**5.2.6.10. NDFC Command IO Register(Default Value: 0x00000000)**

Offset: 0x24			Register Name: <b>NDFC_CMD</b>
Bit	R/W	Default/Hex	Description
31:30	R/W	0	NDFC_CMD_TYPE 00: Common Command for normal operation 01: Special Command for Flash Spare Field Operation 10: Page Command for batch process operation 11: Reserved
29	R/W	0	NDFC_SEND_FOURTH_CMD 0: Don't send third set command 1: Send it on the external memory's bus Notes: It is used for EF-NAND page read.
28	R/W	0	NDFC_SEND_THIRD_CMD 0: Don't send third set command 1: Send it on the external memory's bus Notes: It is used for EF-NAND page read.
27	R/W	0	NDFC_ROW_ADDR_AUTO Row Address Auto Increase for Page Command 0: Normal operation 1: Row address increasing automatically
26	R/W	0	NDFC_DATA_METHOD Data swap method when the internal RAM and system memory It is only active for Common Command and Special Command. 0: No action 1: DMA transfer automatically It only is active when NDFC_RAM_METHOD is 1. If this bit is set to 1, NDFC should setup DRQ to fetching data before output to Flash or NDFC should setup DRQ to sending out to system memory after

			fetching data from Flash. If this bit is set to 0, NDFC output the data in internal RAM or do nothing after fetching data from Flash.
25	R/W	0	<b>NDFC_SEQ</b> User data & BCH check word position. It only is active for Page Command, don't care about this bit for other two commands 0: Interleave Method (on page spare area) 1: Sequence Method (following data block)
24	R/W	0	<b>NDFC_SEND_SECOND_CMD</b> 0: Don't send second set command 1: Send it on the external memory's bus
23	R/W	0	<b>NDFC_WAIT_FLAG</b> 0: NDFC can transfer data regardless of the internal NDFC_RB wire 1: NDFC can transfer data when the internal NDFC_RB wire is READY; otherwise it can't when the internal NDFC_RB wire is BUSY.
22	R/W	0	<b>NDFC_SEND_FIRST_CMD</b> 0: Don't send first set command 1: Send it on the external memory's bus
21	R/W	0	<b>NDFC_DATA_TRANS</b> 0: No data transfer on external memory bus 1: Data transfer and direction is decided by the field NDFC_ACCESS_DIR
20	R/W	0	<b>NDFC_ACCESS_DIR</b> 0: Read NAND Flash 1: Write NAND Flash
19	R/W	0	<b>NDFC_SEND_ADR</b> 0: Don't send ADDRESS 1: Send N cycles ADDRESS, the number N is specified by NDFC_ADR_NUM field
18:16	R/W	0	<b>NDFC_ADR_NUM</b> Address Cycles' Number 000: 1 cycle address field 001: 2 cycles address field 010: 3 cycles address field 011: 4 cycles address field 100: 5 cycles address field 101: 6 cycles address field 110: 7 cycles address field 111: 8 cycles address field
15:8	R/W	0	<b>NDFC_CMD_HIGH_BYTE</b> NDFC Command high byte data If 8-bit command is supported, the high byte should be zero for 16-bit bus width NAND Flash. For 8-bit bus width NAND Flash, high byte command is discarded.
7:0	R/W	0	<b>NDFC_CMD_LOW_BYTE</b> NDFC Command low byte data

			This command will be sent to external Flash by NDFC.
--	--	--	--

**5.2.6.11. NDFC Command Set Register 0(Default Value: 0x00E00530)**

Offset: 0x28			Register Name: <b>NDFC_CMD_SET0</b>
Bit	R/W	Default/Hex	Description
31:24	/	/	/
23:16	R/W	0xE0	NDFC_RANDOM_READ_CMD1 Used for Batch Read Operation
15:8	R/W	0x05	NDFC_RANDOM_READ_CMD0 Used for Batch Read Operation
7:0	R/W	0x30	NDFC_READ_CMD Used for Batch Read Operation

**5.2.6.12. NDFC Command Set Register 1(Default Value: 0x70008510)**

Offset: 0x2C			Register Name: <b>NDFC_CMD_SET1</b>
Bit	R/W	Default/Hex	Description
31:16	R/W	0x70	NDFC_READ_CMD0 Used for EF-NAND Page Read operation
23:16	R/W	0x00	NDFC_READ_CMD1 Used for EF-NAND Page Read operation
15:8	R/W	0x85	NDFC_RANDOM_WRITE_CMD Used for Batch Write Operation
7:0	R/W	0x10	NDFC_PROGRAM_CMD Used for Batch Write Operation

**5.2.6.13. NDFC IO Data Register(Default Value: 0x00000000)**

Offset: 0x30			Register Name: <b>NDFC_IO_DATA</b>
Bit	R/W	Default/Hex	Description
31:0	R/W	0	NDFC_IO_DATA Read/ Write data into internal RAM Access unit is 32-bit.

**5.2.6.14. NDFC ECC Control Register(Default Value: 0x4a800008)**

Offset: 0x34			Register Name: <b>NDFC_ECC_CTL</b>
Bit	R/W	Default/Hex	Description

31	/	/	/
30:16	R/W	0x4a80	<p>NDFC_RANDOM_SEED</p> <p>The seed value for randomize engine. It is only active when NDFC_RANDOM_EN is set to '1'.</p>
15:12	R/W	0	<p>NDFC_ECC_MODE</p> <p>0x0: BCH-16 for one ECC Data Block            0x1: BCH-24 for one ECC Data Block            0x2 : BCH-28 for one ECC Data Block            0x3 : BCH-32 for one ECC Data Block            0x4 : BCH-40 for one ECC Data Block            0x5 : BCH-48 for one ECC Data Block            0x6 : BCH-56 for one ECC Data Block            0x7 : BCH-60 for one ECC Data Block            0x8 : BCH-64 for one ECC Data Block            Others: Reserved</p>
11	R/W	0	<p>NDFC_RANDOM_SIZE</p> <p>0: ECC block size            1: Page size</p>
10	R/W	0	<p>NDFC_RANDOM_DIRECTION</p> <p>0: LSB first            1: MSB first</p>
9	R/W	0	<p>NDFC_RANDOM_EN</p> <p>0: Disable Data Randomize            1: Enable Data Randomize</p>
8:6	/	/	/
5	R/W	0	<p>NDFC_ECC_BLOCK_SIZE</p> <p>0: 1024 bytes of one ECC data block            1: 512 bytes of one ECC data block</p>
4	R/W	0	<p>NDFC_ECC_EXCEPTION</p> <p>0: Normal ECC            1: For ECC, there is an exception. If all data is 0xff or 0x00 for the block. When reading this page, ECC assumes that it is right. For this case, no error information is reported.            Notes: It only is active when ECC is ON</p>
3	R/W	1	<p>NDFC_ECC_PIPELINE</p> <p>Pipeline function enable or disable for batch command            0: Error Correction function no pipeline with next block operation            1: Error Correction pipeline</p>
2:1	/	/	/
0	R/W	0	<p>NDFC_ECC_EN</p> <p>0: ECC is OFF            1: ECC is ON</p>

**5.2.6.15. NDFC ECC Status Register(Default Value: 0x00000000)**

Offset: 0x38			Register Name: <b>NDFC_ECC_ST</b>
Bit	R/W	Default/Hex	Description
31:16	R	0	<b>NDFC_PAT_FOUND</b> Special pattern (all 0x00 or all x0ff) Found Flag for 16 Data Blocks 0: No Found 1: Special pattern is found When this field is '1', this means that the special data is found for reading external NAND flash. The register of NDFC_PAT_ID would indicates which pattern is found.
15:0	R	0	<b>NDFC_ECC_ERR</b> Error information bit of 16 Data Blocks 0: ECC can correct these error bits or there is no error bit 1: Error bits number beyond of ECC correction capability and can't correct them Notes: The LSB of this register is corresponding the 1st ECC data block. 1 ECC Data Block = 512 or 1024 bytes.

**5.2.6.16. NDFC Enhanced Feature Register(Default Value: 0x00000000)**

Offset: 0x3C			Register Name: <b>NDFC_EFR</b>
Bit	R/W	Default/Hex	Description
31:9	R/W	0	/
8	R/W	0	<b>NDFC_WP_CTRL</b> NAND Flash Write Protect Control Bit 0: Write Protect is active 1: Write Protect is not active Notes: When this bit is '0', WP signal line is low level and external NAND flash is on protected state.
7	/	/	/
6:0	R/W	0	<b>NDFC_ECC_DEBUG</b> For the purpose of debugging ECC engine, special bits error are inserted before writing external Flash Memory. 0: No error is inserted (ECC Normal Operation) n: N bits error are inserted

**5.2.6.17. NDFC Error Counter Register 0(Default Value: 0x0000\_0000)**

Offset: 0x40			Register Name: <b>NDFC_ERR_CNT0</b>
Bit	R/W	Default/Hex	Description
[8i+7:8i]	R	0	ECC_COR_NUM

(i=0~3)			<p>ECC Corrected Bits Number for ECC Data Block[n] (n from 0 to 3)</p> <p>0: No corrected bits</p> <p>1: 1 corrected bit</p> <p>2: 2 corrected bits</p> <p>...</p> <p>64: 64 corrected bits</p> <p>Others: Reserved</p> <p>Notes: 1 ECC Data Block = 512 or 1024 bytes</p>
---------	--	--	--

**5.2.6.18. NDFC Error Counter Register 1(Default Value: 0x00000000)**

Offset: 0x44			Register Name: <b>NDFC_ERR_CNT1</b>
Bit	R/W	Default/Hex	Description
[8i+7:8i]			<p>ECC_COR_NUM</p> <p>ECC Corrected Bits Number for ECC Data Block[n] (n from 4 to 7)</p> <p>0: No corrected bits</p> <p>1: 1 corrected bit</p> <p>2: 2 corrected bits</p> <p>...</p> <p>64: 64 corrected bits</p> <p>Others: Reserved</p>
(i=0~3)	R	0	Notes: 1 ECC Data Block = 512 or 1024 bytes

**5.2.6.19. NDFC Error Counter Register 2(Default Value: 0x00000000)**

Offset: 0x48			Register Name: <b>NDFC_ERR_CNT2</b>
Bit	R/W	Default/Hex	Description
[8i+7:8i]			<p>ECC_COR_NUM</p> <p>ECC Corrected Bits Number for ECC Data Block[n] (n from 8 to 11)</p> <p>0: No corrected bits</p> <p>1: 1 corrected bit</p> <p>2: 2 corrected bits</p> <p>...</p> <p>64: 64 corrected bits</p> <p>Others: Reserved</p>
(i=0~3)	R	0	Notes: 1 ECC Data Block = 512 or 1024 bytes

**5.2.6.20. NDFC Error Counter Register 3(Default Value: 0x00000000)**

Offset: 0x4C			Register Name: <b>NDFC_ERR_CNT3</b>
Bit	R/W	Default/Hex	Description



[8i+7:8i]	R	0	<p>ECC_COR_NUM</p> <p>ECC Corrected Bits Number for ECC Data Block[n] (n from 12 to 15)</p> <p>0: No corrected bits</p> <p>1: 1 corrected bit</p> <p>2: 2 corrected bits</p> <p>...</p> <p>64: 64 corrected bits</p> <p>Others: Reserved</p> <p>Notes: 1 ECC Data Block = 512 or 1024 bytes</p>
(i=0~3)			

**5.2.6.21. NDFC User Data Register [n]( Default Value: 0xffffffff)**

Offset: 0x50 + 0x4*n			Register Name: <b>NDFC_USER_DATA<sub>n</sub></b>
Bit	R/W	Default/Hex	Description
31:0	R/W	0xffffffff	<p>USER_DATA</p> <p>User Data for ECC Data Block[n] (n from 0 to 15)</p> <p>Notes: 1 ECC Data Block = 512 or 1024 bytes</p>

**Notes:** n from 0 to 15

**5.2.6.22. NDFC EFNAND STATUS Register(Default Value: 0x00000000)**

Offset: 0x90			Register Name: <b>NDFC_EFNAND_STATUS</b>
Bit	R/W	Default/Hex	Description
31:8	/	/	/
7:0	R	0x0	<p>EF_NAND_STATUS</p> <p>The Status Value for EF-NAND Page Read operation</p>

**5.2.6.23. NDFC Spare Area Register(Default Value: 0x00000400)**

Offset: 0xA0			Register Name: <b>NDFC_SPARE_AREA</b>
Bit	R/W	Default/Hex	Description
31:16	/	/	/
15:0	R/W	0x400	<p>NDFC_SPARE_ADR</p> <p>This value indicates the spare area first byte address for NDFC interleave page operation.</p>

**5.2.6.24. NDFC Pattern ID Register(Default Value: 0x00000000)**

Offset: 0xA4			Register Name: <b>NDFC_PAT_ID</b>
--------------	--	--	-----------------------------------

Bit	R/W	Default/Hex	Description
[2i+1:2i] (i=0~15)	R	0	PAT_ID Special Pattern ID for 16 ECC data block 0: All 0x00 is found 1: All 0xFF is found Others: Reserved

**5.2.6.25. NDFC Read Data Status Control Register(Default Value: 0x01000000)**

Offset: 0xA8			Register Name: NDFC_RDATA_STA_CTL
Bit	R/W	Default/Hex	Description
31:25	/	/	/
24	R/W	1	NDFC_RDATA_STA_EN 0: Disable to count the number of bit 1 and bit 0 during current read operation; 1: Enable to count the number of bit 1 and bit 0 during current read operation; The number of bit 1 and bit 0 during current read operation can be used to check whether a page is blank or bad.
23:18	/	/	/
17:0	R/W	0	NDFC_RDATA_STA_TH The threshold value to generate data status. If the number of bit 1 during current read operation is less than or equal to threshold value, the bit 13 of NDFC_ST register will be set. If the number of bit 0 during current read operation is less than or equal to threshold value, the bit 12 of NDFC_ST register will be set.

**5.2.6.26. NDFC Read Data Status Register 0(Default Value: 0x00000000)**

Offset: 0xAC			Register Name: NDFC_RDATA_STA_0
Bit	R/W	Default/Hex	Description
31:0	R	0	BIT_CNT_1 The number of input bit 1 during current command. It will be cleared automatically when next command is executed.

**5.2.6.27. NDFC Read Data Status Register 1(Default Value: 0x00000000)**

Offset: 0xB0			Register Name: NDFC_RDATA_STA_1
Bit	R/W	Default/Hex	Description
31:0	R	0	BIT_CNT_0 The number of input bit 0 during current command. It will be cleared

			automatically when next command is executed.
--	--	--	--

**5.2.6.28. NDFC MBUS DMA Address Register(Default Value: 0x00000000)**

Offset: 0xC0			Register Name: <b>NDFC_MDMA_ADDR</b>
Bit	R/W	Default/Hex	Description
31:0	R/W	0	MDMA_ADDR MBUS DMA address

**5.2.6.29. NDFC MBUS DMA Byte Counter Register(Default Value: 0x00000000)**

Offset: 0xC4			Register Name: <b>NDFC_MDMA_CNT</b>
Bit	R/W	Default/Hex	Description
14:0	R/W	0	MDMA_CNT MBUS DMA data counter

Confidential

## 5.3. SD/MMC

### 5.3.1. Overview

The SD/MMC controller can be configured either as a Secure Digital Multimedia Card controller, which simultaneously supports Secure Digital memory (SD Memory), Secure Digital I/O (SDIO), Multimedia Cards (MMC), eMMC Card and Consumer Electronics Advanced Transport Architecture (CE-ATA).

The SD/MMC controller includes the following features:

- Supports Secure Digital memory protocol commands (up to SD2.0)
- Supports Secure Digital I/O protocol commands
- Supports Multimedia Card protocol commands (up to eMMC4.41)
- Supports CE-ATA digital protocol commands
- Supports eMMC boot operation and alternative boot operation
- Supports Command Completion signal and interrupt to host processor and Command Completion Signal disable feature
- Supports one SD (Version 1.0 to 3.0) or MMC (Version 3.3 to eMMC4.41) or CE-ATA device
- Supports hardware CRC generation and error detection
- Supports programmable baud rate
- Supports host pull-up control
- Supports SDIO interrupts in 1-bit and 4-bit modes
- Supports SDIO suspend and resume operation
- Supports SDIO read wait
- Supports block size of 1 to 65535 bytes
- Supports descriptor-based internal DMA controller
- Internal 128 bytes FIFO for data transfer

### 5.3.2. Block Diagram

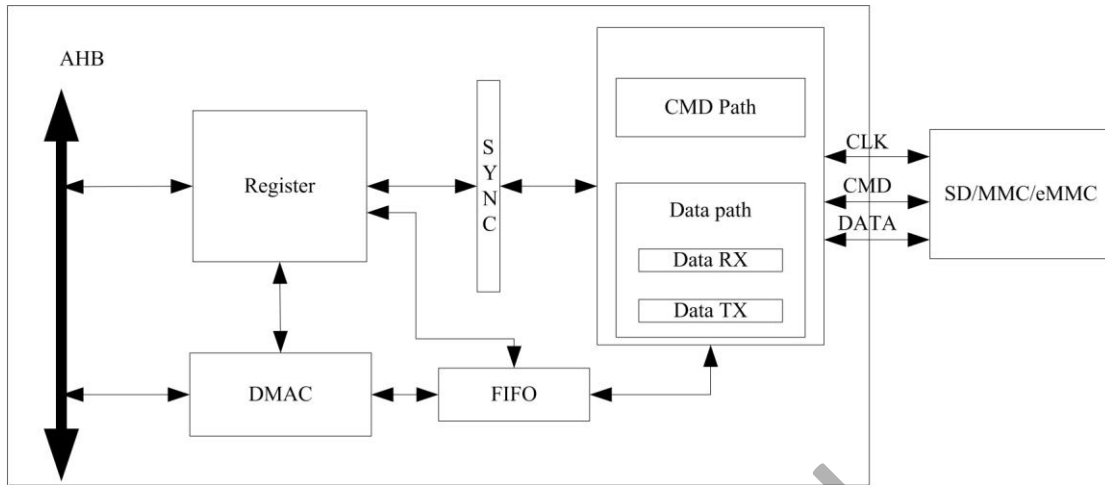

Figure 5-16. SD/MMC Controller Block Diagram

### 5.3.3. SD/MMC Controller Timing Diagram

Please refer to relative specifications:

- Physical Layer Specification Ver3.00 Final,2009.04.16
- SDIO Specification Ver3.00
- Consumer Electronics Advanced Transport Architecture (CE-ATA – version 1.1)
- Multimedia Cards (MMC – version 4.2)
- JEDEC Standard – JESD84-44, EMBEDDED MULTI-MEDIA CARD (e•MMC)

### 5.3.4. SD/MMC Controller Special Requirement

#### 5.3.4.1. SD/MMC Pin List

Port Name	Width	Direction	Description
SD_CCLK	1	OUT	Clock output for SD/SDIO/MMC card
SD_CCMD	1	IN/OUT	CMD line
SD_CDATA	4/8	IN/OUT	Data line

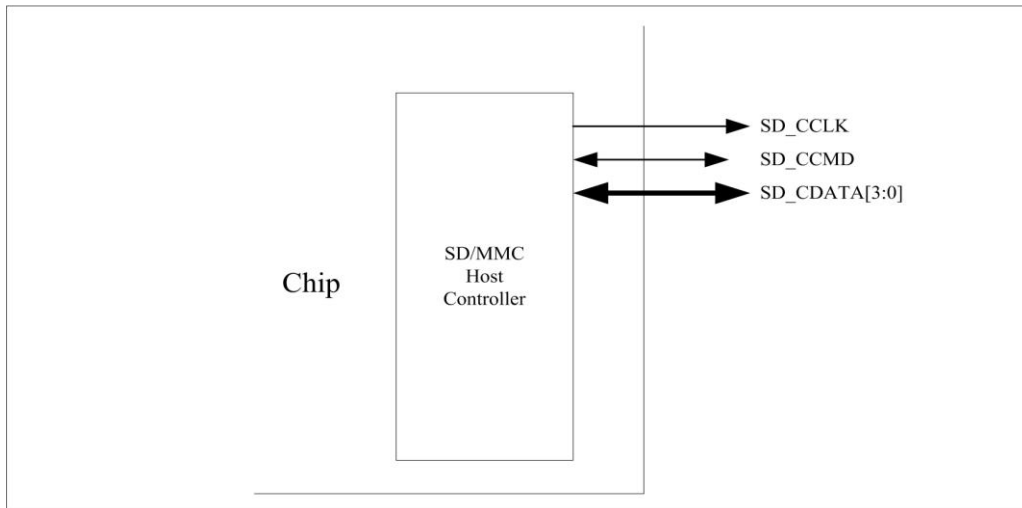

Figure 5-17. SD/MMC Pin Diagram

### 5.3.5. Internal DMA Controller Description

SD/MMC controller has an internal DMA controller (IDMAC) to transfer data between host memory and SDMMC port. With a descriptor, IDMAC can efficiently move data from source to destination by automatically loading next DMA transfer arguments, which need less CPU intervention. Before transfer data in IDMAC, host driver should construct a descriptor list, configure arguments of every DMA transfer, then launch the descriptor and start the DMA. IDMAC has an interrupt controller, when enabled, it can interrupt the HOST CPU in situations such as data transmission completed or some errors happened.

#### 5.3.5.1. IDMAC Descriptor Structure

The IDMAC uses a descriptor with a chain structure, and each descriptor points to a unique buffer and the next descriptor.

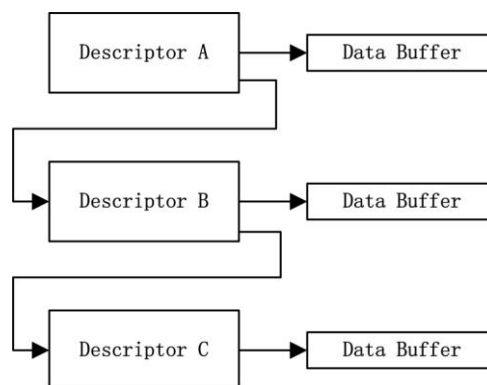

This figure illustrates the internal formats of a descriptor. The descriptor addresses must be aligned to the bus width used for 32-bit buses. Each descriptor contains 16 bytes of control and status information.

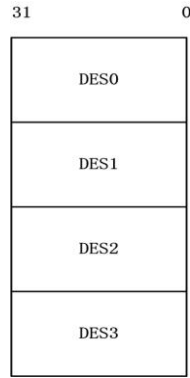

DES0 is a notation used to denote the [31:0] bits, DES1 to denote [63:32] bits, DES2 to denote [95:64]bits, and DES3 to denote [127:96]bits in a descriptor.

**5.3.5.2. DES0 definition**

Bits	Name	Descriptor
31	HOLD	DES_OWN_FLAG When set, this bit indicates that the descriptor is owned by the IDMAC. When this bit is reset, it indicates that the descriptor is owned by the host. This bit is cleared when transfer is over.
30	ERROR	ERR_FLAG When some error happened in transfer, this bit will be set.
29:6	/	/
5	/	Not used
4	Chain Flag	CHAIM_MOD When set, this bit indicates that the second address in descriptor is the next descriptor address. Must be set 1.
3	First DES Flag	FIRST_FLAG When set, this bit indicates that this descriptor contains the first buffer of data. Must be set to 1 in first DES.
2	Last DES Flag	LAST_FLAG When set, this bit indicates that the buffers pointed to by this descriptor are the last data buffer
1	Disable Interrupt on completion	CUR_TXRX_OVER_INT_DIS When set, this bit will prevent the setting of the TX/RX interrupt bit of the IDMAC status register for data that ends in the buffer pointed to by this descriptor
0	/	/

**5.3.5.3. DES1 definition**

Bits	Name	Descriptor
31:16	/	/
15:0	Buffer size	<b>BUFF_SIZE</b> These bits indicate the data buffer byte size, which must be a multiple of 4 bytes. If this field is 0, the DMA ignores this buffer and proceeds to the next descriptor.

**5.3.5.4. DES2 definition**

Bits	Name	Descriptor
31:0	Buffer address pointer	<b>BUFF_ADDR</b> These bits indicate the physical address of data buffer. The IDMAC ignores DES2[1:0], corresponding to the bus width of 32.

**5.3.5.5. DES3 definition**

Bits	Name	Descriptor
31:0	Next descriptor address	<b>NEXT_DESP_ADDR</b> These bits indicate the pointer to the physical memory where the next descriptor is present.

**5.3.6. SD/MMC Register List**

Module Name	Base Address
SD/MMC0	0x01C0F000
SD/MMC1	0x01C10000
SD/MMC2	0x01C11000

Register Name	Offset	Description
SD_GCTL	0x00	Control register
SD_CKCR	0x04	Clock Control register
SD_TMOR	0x08	Time out register
SD_BWDR	0x0C	Bus Width register
SD_BKSR	0x10	Block size register
SD_BYCR	0x14	Byte count register
SD_CMDR	0x18	Command register
SD_CAGR	0x1c	Command argument register
SD_RESP0	0x20	Response 0 register



SD_RESP1	0x24	Response 1 register
SD_RESP2	0x28	Response 2 register
SD_RESP3	0x2C	Response 3 register
SD_IMKR	0x30	Interrupt mask register
SD_MISR	0x34	Masked interrupt status register
SD_RISR	0x38	Raw interrupt status register
SD_STAR	0x3C	Status register
SD_FWLR	0x40	FIFO Water Level register
SD_FUNS	0x44	FIFO Function Select register
SD_A12A	0x58	Auto command 12 argument
SD_NTSR	0x5c	SD NewTiming Set Register
SD_SDBG	0x60	SD NewTiming Set Debug Register
SD_HWRST	0x78	Hardware Reset Register
SD_DMAC	0x80	BUS Mode Control
SD_DLBA	0x84	Descriptor List Base Address
SD_IDST	0x88	DMAC Status
SD_IDIE	0x8c	DMAC Interrupt Enable
SD_THLDC	0x100	Card Threshold Control register
SD_DSBD	0x10c	eMMC4.41 DDR Start Bit Detection Control
SD_RES_CRC	0x110	CRC status from card/eMMC in write operation
SD_DATA7_CRC	0x114	CRC Data7 from card/eMMC
SD_DATA6_CRC	0x118	CRC Data7 from card/eMMC
SD_DATA5_CRC	0x11c	CRC Data7 from card/eMMC
SD_DATA4_CRC	0x120	CRC Data7 from card/eMMC
SD_DATA3_CRC	0x124	CRC Data7 from card/eMMC
SD_DATA2_CRC	0x128	CRC Data7 from card/eMMC
SD_DATA1_CRC	0x12c	CRC Data7 from card/eMMC
SD_DATA0_CRC	0x130	CRC Data7 from card/eMMC
SD_CRC_STA	0x134	Response CRC from card/eMMC
SD_FIFO	0x200	Read/Write FIFO

### 5.3.7. SD/MMC Register Description

#### 5.3.7.1. SD Global Control Register(Default Value: 0x0000300)

Offset: 0x0000			Register Name: <b>SD_CTRL</b>
Bit	R/W	Default/Hex	Description
31	R/W	0	FIFO_AC_MOD FIFO Access Mode 1-AHB bus 0-DMA bus
30:11	-	-	/

10	R/W	0	DDR_MOD_SEL DDR Mode Select 0 – SDR mode 1 – DDR mode
9	-	-	reserved
8	R/W	1	CD_DBC_ENB Card Detect (Data[3] status) De-bounce Enable 0 - disable de-bounce 1 – enable de-bounce
7:6	-	-	/
5	R/W	0	DMA_ENB DMA Global Enable 0 – Disable DMA to transfer data, using AHB bus 1 – Enable DMA to transfer data
4	R/W	0	INT_ENB Global Interrupt Enable 0 – Disable interrupts 1 – Enable interrupts
3	-	-	/
2	R/W	0	DMA_RST DMA Reset
1	R/W	0	FIFO_RST FIFO Reset 0 – No change 1 – Reset FIFO <i>This bit is auto-cleared after completion of reset operation.</i>
0	R/W	0	SOFT_RST Software Reset 0 – No change 1 – Reset SD/MMC controller <i>This bit is auto-cleared after completion of reset operation.</i>

**5.3.7.2. SD Clock Control Register(Default Value: 0x00000000)**

Offset: 0x0004			Register Name: <b>SD_CLKDIV</b>
Bit	R/W	Default/Hex	Description
31	R/W	0	MASK_DATA0 0 - Do not mask data0 when updata clock ; 1 - Mask data0 when updata clock; Default : 0;
30:18	/	/	/
17	R/W	0	CCLK_CTRL Card Clock Output Control 0 – Card clock always on

			1 – Turn off card clock when FSM in IDLE state
16	R/W	0	CCLK_ENB Card Clock Enable 0 – Card Clock off 1 – Card Clock on
15:8	/	/	/
7:0	R/W	0	CCLK_DIV Card clock divider n – Source clock is divided by 2*n.(n=0~255)

**5.3.7.3. SD Timeout Register (Default Value: 0xFFFFF40)**

Offset: 0x0008			Register Name: <b>SD_TMOUT</b>
Bit	R/W	Default/Hex	Description
31:8	R/W	0xfffff	DTO_LMT Data Timeout Limit
7:0	R/W	0x40	RTO_LMT Response Timeout Limit

**5.3.7.4. SD Bus Width Register (Default Value: 0x0000000)**

Offset: 0x000c			Register Name: <b>SD_CTYPE</b>
Bit	R/W	Default/Hex	Description
31:2	/	/	/
1:0	R/W	0	CARD_WID Card width 2'b00 – 1-bit width 2'b01 – 4-bit width 2'b1x – 8-bit width

**5.3.7.5. SD Block Size Register (Default Value: 0x00000200)**

Offset: 0x0010			Register Name: <b>SD_BLKSIZE</b>
Bit	R/W	Default/Hex	Description
31:16	/	/	/
15:0	R/W	0x200	BLK_SZ Block size

**5.3.7.6. SD Block Count Register (Default Value: 0x0000200)**

Offset: 0x0014			Register Name: <b>SD_BYTCNT</b>
Bit	R/W	Default/Hex	Description
31:0	R/W	0x200	<b>BYTE_CNT</b> Byte counter Number of bytes to be transferred; should be integer multiple of Block Size for block transfers.

**5.3.7.7. SD Command Register (Default Value: 0x00000000)**

Offset: 0x0018			Register Name: <b>SD_CMD</b>
Bit	R/W	Default/Hex	Description
31	R/W	0	<b>CMD_LOAD</b> Start Command. This bit is auto cleared when current command is sent. If there is no any response error happened, a command complete interrupt bit (CMD_OVER) will be set in interrupt register. You should not write any other command before this bit is cleared, or a command busy interrupt bit (CMD_BUSY) will be set in interrupt register.
30	/	/	/
29	R/W	0	<b>Use Hold Register</b> 0 - CMD and DATA sent to card bypassing HOLD Register 1 - CMD and DATA sent to card through the HOLD Register
28	R/W	0	<b>VOL_SW</b> Voltage Switch 0 – normal command 1 – Voltage switch command, set for CMD11 only
27	R/W	0	<b>BOOT_ABT</b> Boot Abort Setting this bit will terminate the boot operation.
26	R/W	0	<b>EXP_BOOT_ACK</b> Expect Boot Acknowledge. When Software sets this bit along in mandatory boot operation, controller expects a boot acknowledge start pattern of 0-1-0 from the selected card.
25:24	R/W	0	<b>BOOT_MOD</b> Boot Mode 2'b00 – normal command 2'b01 - Mandatory Boot operation 2'b10 - Alternate Boot operation 2'b11 - reserved
23	R/W	0	<b>CCS_EXP</b> ccs_expected

			<p>0 – Interrupts are not enabled in CE-ATA device (nIEN = 1 in ATA control register), or command does not expect CCS from device</p> <p>1 – Interrupts are enabled in CE-ATA device (nIEN = 0), and RW_BLK command expects command completion signal from CE-ATA device</p> <p>If the command expects Command Completion Signal (CCS) from the CE-ATA device, the software should set this control bit. SD/MMC sets Data Transfer Over bit in RINTSTS register and generates interrupt to host if Data Transfer Over interrupt is not masked.</p>
22	R/W	0	<p>RD_CEATA_DEV read_ceata_device</p> <p>0 – Host is not performing read access (RW_REG or RW_BLK) towards CE-ATA device</p> <p>1 – Host is performing read access (RW_REG or RW_BLK) towards CE-ATA device</p> <p>Software should set this bit to indicate that CE-ATA device is being accessed for read transfer. This bit is used to disable read data timeout indication while performing CE-ATA read transfers. Maximum value of I/O transmission delay can be no less than 10 seconds. SD/MMC should not indicate read data timeout while waiting for data from CE-ATA device.</p>
21	R/W	0	<p>PRG_CLK Change Clock</p> <p>0 – Normal command</p> <p>1 – Change Card Clock; when this bit is set, controller will change clock domain and clock output. No command will be sent.</p>
20:16	-	-	/
15	R/W	0	<p>SEND_INIT_SEQ Send Initialization</p> <p>0 – normal command sending</p> <p>1 – Send initialization sequence before sending this command.</p>
14	R/W	0	<p>STOP_ABT_CMD Stop Abort Command</p> <p>0 – normal command sending</p> <p>1 – send Stop or abort command to stop current data transfer in progress.(CMD12, CMD52 for writing “I/O Abort” in SDIO CCCR)</p>
13	R/W	0	<p>WAIT_PRE_OVER Wait Data Transfer Over</p> <p>0 – Send command at once, do not care of data transferring</p> <p>1 – Wait for data transfer completion before sending current command</p>
12	R/W	0	<p>STOP_CMD_FLAG Send Stop CMD Automatically (CMD12)</p> <p>0 – Do not send stop command at end of data transfer</p> <p>1 – Send stop command automatically at end of data transfer</p>
11	R/W	0	<p>TRANS_MODE Transfer Mode</p> <p>0 – Block data transfer command</p>

			1 – Stream data transfer command
10	R/W	0	TRANS_DIR Transfer Direction 0 – Read operation 1 – Write operation
9	R/W	0	DATA_TRANS Data Transfer 0 – without data transfer 1 – with data transfer
8	R/W	0	CHK_RESP_CRC Check Response CRC 0 – Do not check response CRC 1 – Check response CRC
7	R/W	0	LONG_RESP Response Type 0 –Short Response (48 bits) 1 –Long Response (136 bits)
6	R/W	0	RESP_RCV Response Receive 0 – Command without Response 1 – Command with Response
5:0	R/W	0	CMD_IDX CMD Index Command index value

### 5.3.7.8. SD Command Argument Register (Default Value: 0x00000000)

Offset: 0x001c			Register Name: <b>SD_CMDARG</b>
Bit	R/W	Default/Hex	Description
31:0	R/W	0	CMD_ARG Command argument

### 5.3.7.9. SD Response 0 Register (Default Value: 0x00000000)

Offset: 0x0020			Register Name: <b>SD_RESPO</b>
Bit	R/W	Default/Hex	Description
31:0	R	0	CMD_RESPO response 0 Bit[31:0] of response

**5.3.7.10. SD Response 1 Register (Default Value: 0x00000000)**

Offset: 0x0024			Register Name: <b>SD_RESP1</b>
Bit	R/W	Default/Hex	Description
31:0	R	0	CMD_RESP1 response 1 Bit[63:31] of response

**5.3.7.11. SD Response 2 Register (Default Value: 0x00000000)**

Offset: 0x0028			Register Name: <b>SD_RESP2</b>
Bit	R/W	Default/Hex	Description
31:0	R	0	CMD_RESP2 response 2 Bit[95:64] of response

**5.3.7.12. SD Response 3 Register (Default Value: 0x00000000)**

Offset: 0x002C			Register Name: <b>SD_RESP3</b>
Bit	R/W	Default/Hex	Description
31:0	R	0	CMD_RESP3 response 3 Bit[127:96] of response

**5.3.7.13. SD Interrupt Mask Register (Default Value: 0x00000000)**

Offset: 0x0030			Register Name: <b>SD_INTMASK</b>
Bit	R/W	Default/Hex	Description
31:0	R/W	0	INT_MASK 0 – interrupt masked 1 – interrupt enabled  Bit field defined as following: bit 31– card removed bit 30 – card inserted bit 17~29 - reserved bit 16 – SDIO interrupt bit 15 – Data End-bit error bit 14 – Auto Stop Command done bit 13 – Data Start Error

			bit 12 – Command Busy and illegal write bit 11 – FIFO under run/overflow bit 10 – Data starvation timeout /V1.8 Switch Done bit 9 – Data timeout/Boot data start bit 8 – Response timeout/Boot ACK received bit 7 – Data CRC error bit 6 – Response CRC error bit 5 – Data Receive Request bit 4 –Data Transmit Request bit 3 – Data Transfer Complete bit 2 – Command Complete bit 1 – Response Error (no response or response CRC error) bit 0 – Reserved
--	--	--	---

**5.3.7.14. SD Masked Interrupt Status Register (Default Value: 0x00000000)**

Offset: 0x0034			Register Name: <b>SD_MINTSTS</b>
Bit	R/W	Default/Hex	Description
31:0	R	0	MSKD_ISTA Interrupt status. Enabled only if corresponding bit in mask register is set.  Bit field defined as following: bit 31 – card removed bit 30 – card inserted bit 17~29 - reserved bit 16 – SDIO interrupt bit 15 – Data End-bit error bit 14 – Auto command done bit 13 – Data Start Error bit 12 – Command Busy and illegal write bit 11 – FIFO under run/overflow bit 10 – Data starvation timeout (HTO)/V1.8 Switch Done bit 9 – Data timeout/Boot data start bit 8 – Response timeout/Boot ACK received bit 7 – Data CRC error bit 6 – Response CRC error bit 5 – Data Receive Request bit 4 –Data Transmit Request bit 3 – Data Transfer Complete bit 2 – Command Complete bit 1 – Response Error (no response or response CRC error) bit 0 – Reserved



**5.3.7.15. SD Raw Interrupt Status Register (Default Value: 0x00000000)**

Offset: 0x0038			Register Name: <b>SD_RINTSTS</b>
Bit	R/W	Default/Hex	Description
31:0	R/W	0	<p>RAW_ISTA Raw Interrupt Status. <i>This is write-1-to-clear bits.</i></p> <p>Bit field defined as following:  bit 31 – card removed  bit 30 – card inserted  bit 17~29 - reserved  bit 16 – SDIO interrupt  bit 15 – Data End-bit error  bit 14 – Auto command done  bit 13 – Data Start Error  bit 12 – Command Busy and illegal write  bit 11 – FIFO under run/overflow  bit 10 – Data starvation timeout (HTO)/V1.8 Switch Done  bit 9 – Data timeout/Boot data start  bit 8 – Response timeout/Boot ACK received  bit 7 – Data CRC error  bit 6 – Response CRC error  bit 5 – Data Receive Request  bit 4 –Data Transmit Request  bit 3 – Data Transfer Complete  bit 2 – Command Complete  bit 1 – Response Error (no response or response CRC error)  bit 0 – Reserved</p>

**5.3.7.16. SD Status Register (Default Value: 0x00000006)**

Offset: 0x003C			Register Name: <b>SD_STATUS</b>
Bit	R/W	Default/Hex	Description
31	R	0	<p>DMA_REQ dma_req DMA request signal state</p>
30:22	/	/	/
21:17	R	0	<p>FIFO_LEVEL FIFO Level Number of filled locations in FIFO</p>
16:11	R	0	<p>RESP_IDX Response Index</p>

			Index of previous response, including any auto-stop sent by controller
10	R	0	FSM_BUSY Data FSM Busy Data transmit or receive state-machine is busy
9	R	0	CARD_BUSY Card data busy Inverted version of DATA[0] 0 – card data not busy 1 – card data busy
8	R	0	CARD_PRESENT Data[3] status level of DATA[3]; checks whether card is present 0 – card not present 1 – card present
7:4	R	0	FSM_STA Command FSM states: 0 – Idle 1 – Send init sequence 2 – Tx cmd start bit 3 – Tx cmd tx bit 4 – Tx cmd index + arg 5 – Tx cmd crc7 6 – Tx cmd end bit 7 – Rx resp start bit 8 – Rx resp IRQ response 9 – Rx resp tx bit 10 – Rx resp cmd idx 11 – Rx resp data 12 – Rx resp crc7 13 – Rx resp end bit 14 – Cmd path wait NCC 15 – Wait; CMD-to-response turnaround
3	R	0	FIFO_FULL FIFO full 1 – FIFO full 0 – FIFO not full
2	R	1	FIFO_EMPTY FIFO Empty 1 - FIFO Empty 0 - FIFO not Empty
1	R	1	FIFO_TX_LEVEL FIFO TX Water Level flag 0 – FIFO didn't reach transmit trigger level 1 - FIFO reached transmit trigger level
0	R	0	FIFO_RX_LEVEL

			FIFO TX Water Level flag 0 – FIFO didn't reach receive trigger level 1 - FIFO reached receive trigger level
--	--	--	---

**5.3.7.17. SD FIFO Water Level Register (Default Value: 0x000F0000)**

Offset: 0x0040			Register Name: <b>SD_FIFOTH</b>
Bit	R/W	Default/Hex	Description
31	/	/	/
30:28	R/W	0	BSIZE_OF_TRANS Burst size of multiple transaction 000 – 1 transfers 001 – 4 010 – 8 011 – 16 100 – 32 101 – 64 110 – 128 111 – 256 Should be programmed same as DMA controller multiple transaction size. The units for transfers are the DWORD. A single transfer would be signaled based on this value. Value should be sub-multiple of (RX_TL + 1) and (FIFO_DEPTH - TX_TL) Recommended: MSize = 8, TX_TL = 16, RX_TL = 15
27:21	R	0	/
20:16	R/W	0xF	RX_TL Rx Trigger Level 0x0~0x1e – RX Trigger Level is 0~30 0x1f – reserved FIFO threshold when FIFO request host to receive data from FIFO. When FIFO data level is greater than this value, DMA is request is raised if DMA enabled, or RX interrupt bit is set if interrupt enabled. At the end of packet, if the last transfer is less than this level, the value is ignored and relative request will be raised as usual. Recommended: 15 (means greater than 15)
15:5	R	0	/
4:0	R/W	0	TX_TL TX Trigger Level 0x1~0xf – TX Trigger Level is 1~31 0x0 – no trigger FIFO threshold when FIFO requests host to transmit data to FIFO. When FIFO data level is less than or equal to this value, DMA TX request is raised if DMA enabled, or TX request interrupt bit is set if interrupt enabled. At the end of

			packet, if the last transfer is less than this level, the value is ignored and relative request will be raised as usual. Recommended: 16 (means less than or equal to 16)
--	--	--	--

**5.3.7.18. SD Function Select Register (Default Value: 0x00000000)**

Offset: 0x0044			Register Name: <b>SD_CTRL</b>
Bit	R/W	Default/Hex	Description
31:16	R/W	0	CEATA_EN CEATA Support ON/OFF 0x00000000 – CEATA support on. All hidden CEATA relative bits are accessible normally and these 16 bits return value of 0x1 when be read. Other value – CEATA support off. All hidden CEATA relative bits cannot be access and these 16 bits return value of 0 when be read.
15:11	-	0	/
10	R/W	0	CEATA_ISTA ceata device interrupt status 0 – Interrupts not enabled in CE-ATA device (nIEN = 1 in ATA control register) 1 – Interrupts are enabled in CE-ATA device (nIEN = 0 in ATA control register) Software should appropriately write to this bit after power-on reset or any other reset to CE-ATA device. After reset, usually CE-ATA device interrupt is disabled (nIEN = 1). If the host enables CE-ATA device interrupt, then software should set this bit.
9	R/W	0	SEND_AUTO_STOP_CCSD send auto stop ccsd 0 – Clear bit if SD/MMC does not reset the bit. 1 – Send internally generated STOP after sending CCSD to CEATA device. When set, SD/MMC automatically sends internally generated STOP command (CMD12) to CE-ATA device. After sending internally-generated STOP command, Auto Command Done (ACD) bit in RINTSTS is set and generates interrupt to host if Auto Command Done interrupt is not masked. After sending the CCSD, SD/MMC automatically clears send_auto_stop_ccsd bit.
8	R/W	0	SEND_CCSD send ccsd 0 – Clear bit if SD/MMC does not reset the bit. 1 – Send Command Completion Signal Disable (CCSD) to CE-ATA device When set, SD/MMC sends CCSD to CE-ATA device. Software sets this bit only if current command is expecting CCS (that is, RW_BLK) and interrupts are enabled in CE-ATA device. Once the CCSD pattern is sent to device, SD/MMC automatically clears send_ccsd bit. It also sets Command Done (CD) bit in RINTSTS register and generates interrupt to host if Command Done interrupt is not masked.
7:3	-	-	/

2	R/W	0	<p>ABT_RDATA Abort Read Data 0 – Ignored 1 –After suspend command is issued during read-transfer, software polls card to find when suspend happened. Once suspend occurs, software sets bit to reset data state-machine, which is waiting for next block of data. Used in SDIO card suspends sequence. <i>This bit is auto-cleared once controller reset to idle state.</i></p>
1	R/W	0	<p>READ_WAIT Read Wait 0 – Clear SDIO read wait 1 – Assert SDIO read wait</p>
0	R/W	0	<p>HOST_SEND_MMC_IRQRESQ Host Send MMC IRQ Response 0 – Ignored 1 – Send auto IRQ response When host is waiting MMC card interrupt response, setting this bit will make controller cancel wait state and return to idle state, at which time, controller will receive IRQ response sent by itself. <i>This bit is auto-cleared after response is sent.</i></p>

**5.3.7.19. SD Auto Command 12 Register (Default Value: 0x0000ffff)**

Offset: 0x0058			Register Name: <b>SD_A12A</b>
Bit	R/W	Default/Hex	Description
31:16	-	-	/
0:15	R/W	0xffff	SD_A12A. SD_A12A set the argument of command 12 automatically send by controller

**5.3.7.20. SD NewTiming Set Register (Default Value: 0x00000001,only used in SDC1/2)**

Offset: 0x005C			Register Name: <b>SD_NTSR_REG</b>
Bit	R/W	Default/Hex	Description
31	R/W	0	<p>MODE_SELEC 0 - Old mode of Sample/Output Timing ; 1 - New mode of Sample/Output Timing; Default : 0;</p>
30:6	R/W	0x00	<p>SAMPLE_TIMING_PHASE(RX) 00 - Sample timing phase offset 90。 ; 01 - Sample timing phase offset 180。 ; 10 - Sample timing phase offset 270。 ; 11 - Ignore;</p>

			Default : 00;
3:2	/	/	/
1:0	R/W	0x01	OUTPUT_TIMING_PHASE(TX) 00 - Output timing phase offset 90。 ; 01 - Output timing phase offset 180。 ; 10 - Output timing phase offset 270。 ; 11 - Ignore; Default : 01;

**5.3.7.21. SD Hardware Reset Register (Default Value: 0x00000001)**

Offset: 0x0078			Register Name: <b>SD_HWRST</b>
Bit	R/W	Default/Hex	Description
31:1	/	/	/
0	R/W	1	HW_RESET. 1 – Active mode 0 – Reset These bits cause the cards to enter pre-idle state, which requires them to be re-initialized.

**5.3.7.22. SD DMAC Control Register (Default Value: 0x00000000)**

Offset: 0x0080			Register Name: <b>SD_BUS_MODE</b>
Bit	R/W	Default/Hex	Description
31	W	0	DES_LOAD_CTRL When DMAC fetches a descriptor, if the valid bit of a descriptor is not set, DMAC FSM will go to the suspend state. Setting this bit will make DMAC re-fetch descriptor again and do the transfer normally.
10:8	R	0	PRG_BURST_LEN Programmable Burst Length. These bits indicate the maximum number of beats to be performed in one IDMAC transaction. The IDMAC will always attempt to burst as specified in PBL each time it starts a Burst transfer on the host bus. The permissible values are 1, 4, 8, 16, 32, 64, 128 and 256. This value is the mirror of MSIZE of FIFOTH register. In order to change this value, write the required value to FIFOTH register. This is an encode value as follows. 000 – 1 transfers 001 – 4 transfers 010 – 8 transfers 011 – 16 transfers 100 – 32 transfers

			101 – 64 transfers 110 – 128 transfers 111 – 256 transfers Transfer unit is either 16, 32, or 64 bits, based on HDATA_WIDTH. PBL is a read-only value.
7	R/W	0	IDMAC_ENB IDMAC Enable. When set, the IDMAC is enabled. DE is read/write.
6:2	R/W	0	DES_SKIP_LEN Descriptor Skip Length. Specifies the number of Word to skip between two unchained descriptors. This is applicable only for dual buffer structure. Default is set to 4 DWORD.
1	R/W	0	FIX_BUST_CTRL Fixed Burst. Controls whether the AHB Master interface performs fixed burst transfers or not. When set, the AHB will use only SINGLE, INCR4, INCR8 during start of normal burst transfers. When reset, the AHB will use SINGLE and INCR burst transfer operations.
0	R/W	0	IDMAC_RST DMA Reset. When set, the DMA Controller resets all its internal registers. SWR is read/write. It is automatically cleared after 1 clock cycle.

**5.3.7.23. SD Descriptor List Base Address Register (Default Value: 0x00000000)**

Offset: 0x0084			Register Name: <b>SD_DLBA</b>
Bit	R/W	Default/Hex	Description
31:0	R/W	0	DES_BASE_ADDR Start of Descriptor List. Contains the base address of the First Descriptor. The LSB bits [1:0] are ignored and taken as all-zero by the IDMAC internally. Hence these LSB bits are read-only.

**5.3.7.24. SD DMAC Status Register (Default Value: 0x0000\_0000)**

Offset: 0x0088			Register Name: <b>SD_DSR</b>
Bit	R/W	Default/Hex	Description
31:17	/	/	/
16:13	R	0	DMAC_FSM_STA DMAC FSM present state. 0 – DMA_IDLE

			1 – DMA_SUSPEND 2 – DESC_RD 3 – DESC_CHK 4 – DMA_RD_REQ_WAIT 5 – DMA_WR_REQ_WAIT 6 – DMA_RD 7 – DMA_WR 8 – DESC_CLOSE This bit is read-only.
12:10	R	0	DMAC_ERR_STA Error Bits. Indicates the type of error that caused a Bus Error. Valid only with Fatal Bus Error bit (IDSTS[2]) set. This field does not generate an interrupt. 3'b001 – Host Abort received during transmission 3'b010 – Host Abort received during reception Others: Reserved EB is read-only.
9	R/W	0	ABN_INT_SUM Abnormal Interrupt Summary. Logical OR of the following: IDSTS[2] – Fatal Bus Interrupt IDSTS[4] – DU bit Interrupt IDSTS[5] – Card Error Summary Interrupt Only unmasked bits affect this bit. This is a sticky bit and must be cleared each time a corresponding bit that causes AIS to be set is cleared. Writing a 1 clears this bit.
8	R/W	0	NOR_INT_SUM Normal Interrupt Summary. Logical OR of the following: IDSTS[0] – Transmit Interrupt IDSTS[1] – Receive Interrupt Only unmasked bits affect this bit. This is a sticky bit and must be cleared each time a corresponding bit that causes NIS to be set is cleared. Writing a 1 clears this bit.
7:6	/	/	/
5	R/W	0	ERR_FLAG_SUM Card Error Summary. Indicates the status of the transaction to/from the card; also present in RINTSTS. Indicates the logical OR of the following bits: EBE – End Bit Error RTO – Response Timeout/Boot Ack Timeout RCRC – Response CRC SBE – Start Bit Error DRTO – Data Read Timeout/BDS timeout DCRC – Data CRC for Receive RE – Response Error



			<i>Writing 1 clears this bit.</i>
4	R/W	0	DES_UNAVL_INT Descriptor Unavailable Interrupt. This bit is set when the descriptor is unavailable due to OWN bit = 0 (DES0[31]=0). Writing a 1 clears this bit.
3	/	/	/
2	R/W	0	FATAL_BERR_INT Fatal Bus Error Interrupt. Indicates that a Bus Error occurred (IDSTS[12:10]). When this bit is set, the DMA disables all its bus accesses. Writing a 1 clears this bit.
1	R/W	0	RX_INT Receive Interrupt. Indicates the completion of data reception for a descriptor. Writing a 1 clears this bit.
0	R/W	0	TX_INT Transmit Interrupt. Indicates that data transmission is finished for a descriptor. Writing a '1' clears this bit.

**5.3.7.25. SD DMAC Interrupt Enable Register (Default Value: 0x00000000)**

Offset: 0x008C			Register Name: <b>SD_IDIE_REG</b>
Bit	R/W	Default/Hex	Description
31:10	/	/	/
9	R/W	0	ABN_INT_ENB Abnormal Interrupt Summary Enable. When set, an abnormal interrupt is enabled. This bit enables the following bits: IDINTEN[2] – Fatal Bus Error Interrupt IDINTEN[4] – DU Interrupt IDINTEN[5] – Card Error Summary Interrupt
8	R/W	0	NOR_INT_ENB Normal Interrupt Summary Enable. When set, a normal interrupt is enabled. When reset, a normal interrupt is disabled. This bit enables the following bits: IDINTEN[0] – Transmit Interrupt IDINTEN[1] – Receive Interrupt
7:6	/	/	/
5	R/W	0	ERR_SUM_INT_ENB Card Error summary Interrupt Enable. When set, it enables the Card Interrupt summary.
4	R/W	0	DES_UNAVL_INT_ENB Descriptor Unavailable Interrupt. When set along with Abnormal Interrupt Summary Enable, the DU interrupt

			is enabled.
3	/	/	/
2	R/W	0	FERR_INT_ENB Fatal Bus Error Enable. When set with Abnormal Interrupt Summary Enable, the Fatal Bus Error Interrupt is enabled. When reset, Fatal Bus Error Enable Interrupt is disabled.
1	R/W	0	RX_INT_ENB Receive Interrupt Enable. When set with Normal Interrupt Summary Enable, Receive Interrupt is enabled. When reset, Receive Interrupt is disabled.
0	R/W	0	TX_INT_ENB Transmit Interrupt Enable. When set with Normal Interrupt Summary Enable, Transmit Interrupt is enabled. When reset, Transmit Interrupt is disabled.

**5.3.7.26. Card Threshold Control Register (Default Value: 0x00000000)**

Offset: 0x0100			Register Name: <b>SD_THLD_REG</b>
Bit	R/W	Default/Hex	Description
31:28	/	/	/
27:16	R/W	0	CARD_RD_THLD Card Read Threshold Size
15:1	/	/	/
0	R/W	0	CARD_RD_THLD_ENB Card Read Threshold Enable 0 – Card Read Threshold Disable 1 - Card Read Threshold Enable Host controller initiates Read Transfer only if CARD_RD_THLD amount of space is available in receive FIFO

**5.3.7.27. eMMC4.41 DDR Start Bit Detection Control Register (Default Value: 0x00000000)**

Offset: 0x010C			Register Name: <b>EMMC_DDR_SBIT_DET_REG</b>
Bit	R/W	Default/Hex	Description
31:1	/	/	/
0	R/W	0	HALF_START_BIT Control for start bit detection mechanism inside mstorage based on duration of start bit. For eMMC 4.41, start bit can be: 0 - Full cycle 1 - Less than one full cycle

			Set HALF_START_BIT=1 for eMMC 4.41 and above; set to 0 for SD applications.
--	--	--	---

**5.3.7.28. SD Response CRC Register (Default Value: 0x00000000)**

Offset: 0x0110			Register Name: <b>RESP_CRC_REG</b>
Bit	R/W	Default/Hex	Description
31:7	/	/	/
6:0	R	0	RESP_CRC Response CRC Response CRC from card/eMMC.

**5.3.7.29. SD Data7 CRC Register (Default Value: 0x00000000)**

Offset: 0x0114			Register Name: <b>DATA7_CRC_REG</b>
Bit	R/W	Default/Hex	Description
31:0	R	0	DATA7_CRC Data[7] CRC CRC in data[7] from card/eMMC. In DDR mode, the higher 16 bits indicate the CRC of even data, and the lower 16 bits indicate the CRC of odd data. In SDR mode, the higher of 16 bits indicate the CRC of all data.

**5.3.7.30. SD Data6 CRC Register (Default Value: 0x00000000)**

Offset: 0x0118			Register Name: <b>DATA6_CRC_REG</b>
Bit	R/W	Default/Hex	Description
31:0	R	0	DATA6_CRC Data[6] CRC CRC in data[6] from card/eMMC. In DDR mode, the higher 16 bits indicate the CRC of even data, and the lower 16 bits indicate the CRC of odd data. In SDR mode, the higher of 16 bits indicate the CRC of all data.

**5.3.7.31. SD Data5 CRC Register (Default Value: 0x00000000)**

Offset: 0x011c			Register Name: <b>DATA5_CRC_REG</b>
Bit	R/W	Default/Hex	Description
31:0	R	0	DATA5_CRC Data[5] CRC CRC in data[5] from card/eMMC. In DDR mode, the higher 16 bits indicate the

			CRC of even data,and the lower 16bits indicate the CRC of odd data.In SDR mode,the higher of 16 bits indicate the CRC of all data.
--	--	--	--

**5.3.7.32. SD Data4 CRC Register (Default Value: 0x00000000)**

Offset: 0x0120			Register Name: <b>DATA4_CRC_REG</b>
Bit	R/W	Default/Hex	Description
31:0	R	0	DATA4_CRC Data[4] CRC CRC in data[4] from card/eMMC.In DDR mode,the higher 16 bits indicate the CRC of even data,and the lower 16bits indicate the CRC of odd data.In SDR mode,the higher of 16 bits indicate the CRC of all data.

**5.3.7.33. SD Data3 CRC Register (Default Value: 0x00000000)**

Offset: 0x0124			Register Name: <b>DATA3_CRC_REG</b>
Bit	R/W	Default/Hex	Description
31:0	R	0	DATA3_CRC Data[3] CRC CRC in data[3] from card/eMMC. In 8bit DDR mode,the higher 16 bits indicate the CRC of even data,and the lower 16bits indicate the CRC of odd data. In 4 bit DDR mode,the higher of 16 bits indicate the CRC of odd data, ,and the lower 16bits indicate the CRC of even data. In SDR mode,the higher of 16 bits indicate the CRC of all data.

**5.3.7.34. SD Data2 CRC Register (Default Value: 0x00000000)**

Offset: 0x0128			Register Name: <b>DATA2_CRC_REG</b>
Bit	R/W	Default/Hex	Description
31:0	R	0	DATA2_CRC Data[2] CRC CRC in data[2] from card/eMMC. In 8bit DDR mode,the higher 16 bits indicate the CRC of even data,and the lower 16bits indicate the CRC of odd data. In 4 bit DDR mode,the higher of 16 bits indicate the CRC of odd data, ,and the lower 16bits indicate the CRC of even data. In SDR mode,the higher of 16 bits indicate the CRC of all data.

**5.3.7.35. SD Data1 CRC Register (Default Value: 0x00000000)**

Offset: 0x012c			Register Name: <b>DATA1_CRC_REG</b>
Bit	R/W	Default/Hex	Description
31:0	R	0	<p>DATA1_CRC Data[1] CRC CRC in data[1] from card/eMMC.</p> <p>In 8bit DDR mode,the higher 16 bits indicate the CRC of even data,and the lower 16bits indicate the CRC of odd data.</p> <p>In 4 bit DDR mode,the higher of 16 bits indicate the CRC of odd data, ,and the lower 16bits indicate the CRC of even data.</p> <p>In SDR mode,the higher of 16 bits indicate the CRC of all data.</p>

**5.3.7.36. SD Data0 CRC Register (Default Value: 0x00000000)**

Offset: 0x0130			Register Name: <b>DATA0_CRC_REG</b>
Bit	R/W	Default/Hex	Description
31:0	R	0	<p>DATA0_CRC Data[0] CRC CRC in data[0] from card/eMMC.</p> <p>In 8bit DDR mode,the higher 16 bits indicate the CRC of even data,and the lower 16bits indicate the CRC of odd data.</p> <p>In 4 bit DDR mode,the higher of 16 bits indicate the CRC of odd data, ,and the lower 16bits indicate the CRC of even data.</p> <p>In SDR mode,the higher of 16 bits indicate the CRC of all data.</p>

**5.3.7.37. SD CRC Status Register (Default Value: 0x00000000)**

Offset: 0x0134			Register Name: <b>CRC_STA_REG</b>
Bit	R/W	Default/Hex	Description
31:3	/	/	/
2:0	R	0	<p>CRC_STA CRC Status CRC status from card/eMMC in write operation Positive CRC status token:3'b010 Negative CRC status token:3'b101</p>

**5.3.7.38. SD FIFO Register (Default Value: 0x00000000)**

Offset: 0x0200			Register Name: <b>SD_FIFO_REG</b>
----------------	--	--	-----------------------------------

Bit	R/W	Default/Hex	Description
31:0	R/W	0	TX/RX_FIFO Data FIFO

Confidential

# Chapter 6 Image

This section describes the image input of H3:

- CSI

## 6.1. CSI

### 6.1.1. Overview

The CSI includes the following feature:

#### CSI

- Support 8bit yuv422 CMOS sensor interface
- Support CCIR656 protocol for NTSC and PAL
- Maximum still capture resolution to 5M
- Maximum video capture resolution to 1080@30fps

#### CCI

- Compatible with i2c transmission in 7 bit slave ID + 1 bit R/W
- Automatic transmission
- 0/8/16/32 bit register address supported
- 8/16/32 bit data supported
- 64bytes-FIFO input CCI data supported
- Synchronized with CSI signal and delay trigger supported
- Repeated transmission with sync signal supported

### 6.1.2. Functionalities Description

#### 6.1.2.1. Block Diagram

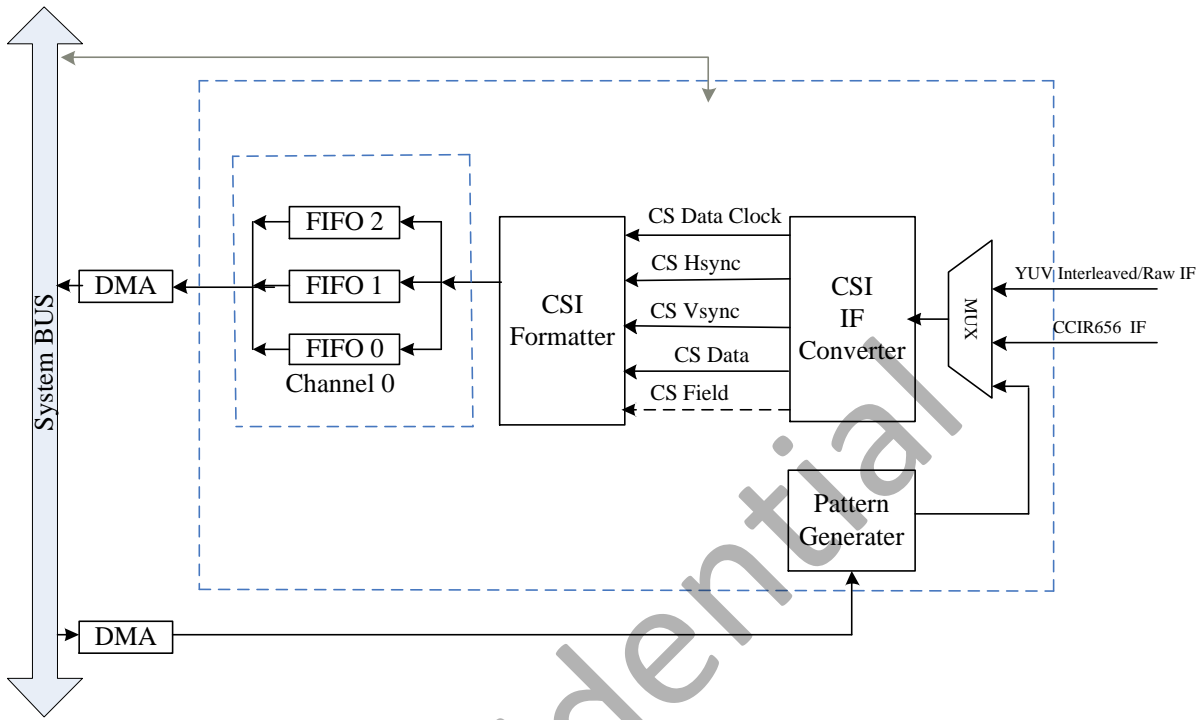

Figure 6-1. CSI Block Diagram

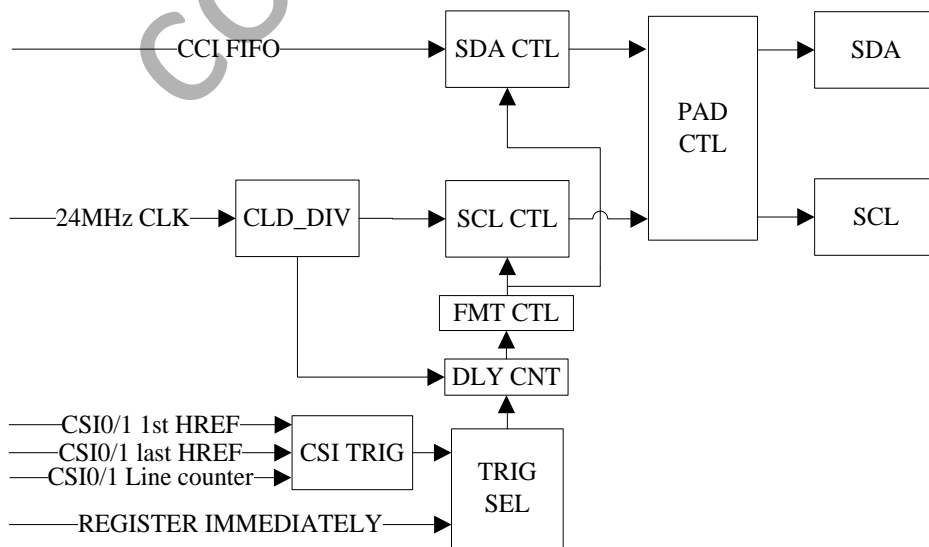

Figure 6-2. CCI Block Diagram



**6.1.2.2. CSI FIFO Distribution**

Interface	YUYV422 Interleaved/Raw			BT656 Interface	
Input format	YUV422		Raw	YUV422	
Output format	Planar	UV combined/ MB	Raw/RGB/PRGB	Planar	UV combined/MB
CH0_FIFO0	Y pixel data	Y pixel data	All pixels data	Y	Y
CH0_FIFO1	Cb (U) pixel data	Cb (U) Cr (V) pixel data	-	Cb (U)	CbCr (UV)
CH0_FIFO2	Cr (V) pixel data	-	-	Cr (V)	

**6.1.2.3. CSI Timing**

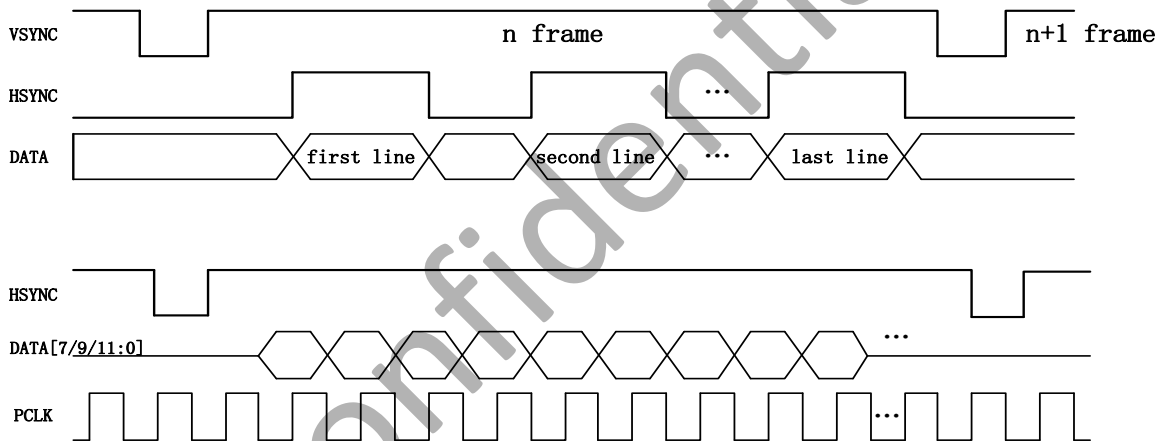

Figure 6-3. 8/10/12-bit CMOS Sensor Interface Timing  
(clock rising edge sample.vsync valid = positive,hsync valid = positive)

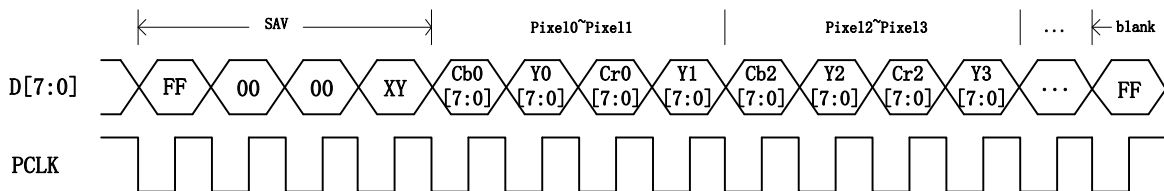

Figure 6-4. 8-bit YCbCr4:2:2 with embedded syncs(BT656) Timing

### 6.1.2.4. Bit Definition

#### CCIR656 Header Data Bit Definition:

Data Bit	First Word(0xFF)	Second Word(0x00)	Third Word(0x00)	Fourth Word
CS D[9] (MSB)	1	0	0	1
CS D[8]	1	0	0	F
CS D[7]	1	0	0	V
CS D[6]	1	0	0	H
CS D[5]	1	0	0	P3
CS D[4]	1	0	0	P2
CS D[3]	1	0	0	P1
CS D[2]	1	0	0	P0
CS D[1]	x	x	x	x
CS D[0]	x	x	x	x

**Note:** For compatibility with 8-bit interface, CS D[1] and CS D[0] are not defined.

Decode	F	V	H	P3	P2	P1	P0
Field 1 start of active video (SAV)	0	0	0	0	0	0	0
Field 1 end of active video (EAV)	0	0	1	1	1	0	1
Field 1 SAV (digital blanking)	0	1	0	1	0	1	1
Field 1 EAV (digital blanking)	0	1	1	0	1	1	0
Field 2 SAV	1	0	0	0	1	1	1
Field 2 EAV	1	0	1	1	0	1	0
Field 2 SAV (digital blanking)	1	1	0	1	1	0	0
Field 2 EAV (digital blanking)	1	1	1	0	0	0	1

### 6.1.3. Register list

Module Name	Base Address
CSIO	0x01CB0000

Register Name	Offset	Register name
CSIO_EN_REG	0X0000	CSI Enable register
CSIO_IF_CFG_REG	0X0004	CSI Interface Configuration Register
CSIO_CAP_REG	0X0008	CSI Capture Register
CSIO_SYNC_CNT_REG	0X000C	CSI Synchronization Counter Register
CSIO_FIFO_THRS_REG	0X0010	CSI FIFO Threshold Register
CSIO_PTN_LEN_REG	0X0030	CSI Pattern Generation Length register
CSIO_PTN_ADDR_REG	0X0034	CSI Pattern Generation Address register
CSIO_VER_REG	0X003C	CSI Version Register
CSIO_C0_CFG_REG	0X0044	CSI Channel_0 configuration register

CSIO_CO_SCALE_REG	0X004C	CSI Channel_0 scale register
CSIO_CO_F0_BUFA_REG	0X0050	CSI Channel_0 FIFO 0 output buffer-A address register
CSIO_CO_F1_BUFA_REG	0X0058	CSI Channel_0 FIFO 1 output buffer-A address register
CSIO_CO_F2_BUFA_REG	0X0060	CSI Channel_0 FIFO 2 output buffer-A address register
CSIO_CO_CAP_STA_REG	0X006C	CSI Channel_0 status register
CSIO_CO_INT_EN_REG	0X0070	CSI Channel_0 interrupt enable register
CSIO_CO_INT_STA_REG	0X0074	CSI Channel_0 interrupt status register
CSIO_CO_HSIZE_REG	0X0080	CSI Channel_0 horizontal size register
CSIO_CO_VSIZE_REG	0X0084	CSI Channel_0 vertical size register
CSIO_CO_BUF_LEN_REG	0X0088	CSI Channel_0 line buffer length register
CSIO_CO_FLIP_SIZE_REG	0X008C	CSI Channel_0 flip size register
CSIO_CO_FRM_CLK_CNT_REG	0X0090	CSI Channel_0 frame clock counter register
CSIO_CO_ACC_ITNL_CLK_CNT_REG	0X0094	CSI Channel_0 accumulated and internal clock counter register
CSIO_CO_FIFO_STAT_REG	0X0098	CSI Channel_0 FIFO Statistic Register
CSIO_CO_PCLK_STAT_REG	0X009C	CSI Channel_0 PCLK Statistic Register
CCI_CTRL	0x3000	CCI control register
CCI_CFG	0x3004	CCI transmission config register
CCI_FMT	0x3008	CCI packet format register
CCI_BUS_CTRL	0x300C	CCI bus control register
CCI_INT_CTRL	0x3014	CCI interrupt control register
CCI_LC_TRIG	0x3018	CCI line counter trigger register
CCI_FIFO_ACC	0x3100	CCI FIFO access register
CCI_RSV_REG	0x3200	CCI reserved register

### 6.1.4. Register Description

#### 6.1.4.1. CSI Enable Register (Default Value: 0x00000000)

Offset: 0x0000			Register Name: CSIO_EN_REG
Bit	R/W	Default/Hex	Description
31	/	/	/
30	R/W	0x0	VER_EN CSI Version Register Read Enable: 0: Disable 1: Enable
29:24	/	/	/
23:16	R/W	0x00	PTN_CYCLE Pattern generating cycle counter. The pattern in dram will be generated in cycles of PTN_CYCLE+1.
15:9	/	/	/
8	R/W	0x0	SRAM_PWDN 0: SRAM in normal

			1: SRAM in power down
7:5	/	/	/
4	R/W	0x0	PTN_START CSI Pattern Generating Start 0: Finish other: Start Software write this bit to "1" to start pattern generating from DRAM. When finished, the hardware will clear this bit to "0" automatically. Generating cycles depends on PTN_CYCLE.
3	R/W	0	CLK_CNT_SPL Sampling time for clk counter per frame 0: Sampling clock counter every frame done 1: Sampling clock counter every vsync
2	R/W	0	CLK_CNT_EN clk count per frame enable
1	R/W	0	PTN_GEN_EN Pattern Generation Enable
0	R/W	0	CSI_EN Enable 0: Reset and disable the CSI module 1: Enable the CSI module

#### 6.1.4.2. CSI Interface Configuration Register (Default Value: 0x00000000)

Offset: 0x0004			Register Name: CSIO_IF_CFG_REG
Bit	R/W	Default/Hex	Description
31:22	/	/	/
21	R/W	0	SRC_TYPE Source type 0: Progressed 1: Interlaced
20	R/W	0	FPS_DS Fps down sample 0: no down sample 1: 1/2 fps, only receives the first frame every 2 frames
19	R/W	0	FIELD For YUV HV timing, Field polarity 0: negative(field=0 indicate odd, field=1 indicate even ) 1: positive(field=1 indicate odd, field=0 indicate even ) For BT656 timing, Field sequence 0: Normal sequence (field 0 first) 1: Inverse sequence (field 1 first)
18	R/W	1	VREF_POL Vref polarity

			0: negative 1: positive This register is not apply to CCIR656 interface.
17	R/W	0	HERF_POL Href polarity 0: negative 1: positive This register is not apply to CCIR656 interface.
16	R/W	1	CLK_POL Data clock type 0: active in rising edge 1: active in falling edge
15:12	/	/	/
11:10	R/W	0	SEQ_8PLUS2 When select IF_DATA_WIDTH to be 8+2bit, odd/even pixel byte at CSI-D[11:4] will be rearranged to D[11:2]+2'b0 at the actual csi data bus according to these sequences: 00: 6'bx+D[9:8], D[7:0] 01: D[9:2], 6'bx+D[1:0] 10: D[7:0], D[9:8]+6'bx 11: D[7:0], 6'bx+D[9:8]
9:8	R/W	0	IF_DATA_WIDTH 00: 8 bit data bus 01: 10 bit data bus 10: 12 bit data bus 11: 8+2bit data bus
7:5	/	/	/
4:0	R/W	0	CSI_IF YUV: 00000: YUYV422 Interleaved or RAW (All data in one data bus) CCIR656: 00100: YUYV422 Interleaved or RAW (All data in one data bus) Others: Reserved

**6.1.4.3. CSI Capture Register (Default Value: 0x00000000)**

Offset: 0x0008			Register Name: <b>CSIO_CAP_REG</b>
Bit	R/W	Default/Hex	Description
31:6	/	/	/
5:2	R/W	0x0	CH0_CAP_MASK Vsync number masked before capture.
1	R/W	0x0	CH0_VCAP_ON Video capture control: Capture the video image data stream on channel 0. 0: Disable video capture

			<p>If video capture is in progress, the CSI stops capturing image data at the end of the current frame, and all of the current frame data is wrote to output FIFO.</p> <p>1: Enable video capture</p> <p>The CSI starts capturing image data at the start of the next frame.</p>
0	R/W	0x0	<p>CH0_SCAP_ON</p> <p>Still capture control: Capture a single still image frame on channel 0.</p> <p>0: Disable still capture.</p> <p>1: Enable still capture</p> <p>The CSI module starts capturing image data at the start of the next frame.</p> <p>The CSI module captures only one frame of image data. This bit is self clearing and always reads as a 0.</p>

#### 6.1.4.4. CSI Synchronization Counter Register (Default Value: 0x00000000)

Offset: 0x000C			Register Name: <b>CSIO_SYNC_CNT_REG</b>
Bit	R/W	Default/Hex	Description
31:24	/	/	/
23:0	R	0	<p>SYNC_CNT</p> <p>The counter value between vsync of CSIO channel 0 and vsync of CSI1 channel 0 , using 24MHz.</p>

#### 6.1.4.5. CSI FIFO Threshold Register (Default Value: 0x040f0400)

Offset: 0x0010			Register Name: <b>CSIO_FIFO_THRS_REG</b>
Bit	R/W	Default/Hex	Description
31:29	/	/	/
28:26	R/W	0x1	<p>FIFO_NEARLY_FULL_TH</p> <p>The threshold of FIFO being nearly full. Indicates that the ISP should stop writing. Only valid when ISP is enabled.</p> <p>0~7:</p> <p>The smaller the value, the flag of FIFO being nearly full is easier to reach.</p>
25:24	R/W	0x0	<p>PTN_GEN_CLK_DIV</p> <p>Packet generator clock divider</p>
23:16	R/W	0x0f	<p>PTN_GEN_DLY</p> <p>Clocks delayed before pattern generating start.</p>
15:12	/	/	/
11:00	R/W	0x400	<p>FIFO_THRS</p> <p>When CSIO FIFO occupied memory exceed the threshold, dram frequency can not change.</p>

**6.1.4.6. CSI Pattern Generation Length Register (Default Value: 0x00000000)**

Offset: 0x0030			Register Name: <b>CSIO_PTN_LEN_REG</b>
Bit	R/W	Default/Hex	Description
31:0	R/W	0x0	PTN_LEN The pattern length in byte when generating pattern.

**6.1.4.7. CSI Pattern Generation Address Register (Default Value: 0x00000000)**

Offset: 0x0034			Register Name: <b>CSIO_PTN_ADDR_REG</b>
Bit	R/W	Default/Hex	Description
31:0	R/W	0x0	PTN_ADDR The pattern DRAM address when generating pattern.

**6.1.4.8. CSI Version Register (Default Value: 0x00000000)**

Offset: 0x003C			Register Name: <b>CSIO_VER_REG</b>
Bit	R/W	Default/Hex	Description
31:0	R	0x0	VER Version of hardware circuit. Only can be read when version register read enable is on.

**6.1.4.9. CSI Channel\_0 configuration Register (Default Value: 0x00300200)**

Offset: 0x0044			Register Name: <b>CSIO_CO_CFG_REG</b>
Bit	R/W	Default/Hex	Description
31:24	R/W	0	PAD_VAL Padding value when OUTPUT_FMT is prgb888 0x00~0xff
23:20	R/W	3	INPUT_FMT Input data format 0000: RAW stream 0001: reserved 0010: reserved 0011: YUV422 0100: YUV420 Others: reserved
19:16	R/W	0	OUTPUT_FMT Output data format When the input format is set RAW stream

			<p>0000: field-raw-8  0001: field-raw-10  0010: field-raw-12  0011: reserved  0100: field-rgb565  0101: field-rgb888  0110: field-prgb888  1000: frame-raw-8  1001: frame-raw-10  1010: frame-raw-12  1011: reserved  1100: frame-rgb565  1101: frame-rgb888  1110: frame-prgb888</p> <p>When the input format is set YUV422  0000: field planar YCbCr 422  0001: field planar YCbCr 420  0010: frame planar YCbCr 420  0011: frame planar YCbCr 422  0100: field planar YCbCr 422 UV combined  0101: field planar YCbCr 420 UV combined  0110: frame planar YCbCr 420 UV combined  0111: frame planar YCbCr 422 UV combined  1000: field MB YCbCr 422  1001: field MB YCbCr 420  1010: frame MB YCbCr 420  1011: frame MB YCbCr 422  1100: field planar YCbCr 422 10bit UV combined  1101: field planar YCbCr 420 10bit UV combined  1110: Reserved  1111: Reserved</p> <p>When the input format is set YUV420  0000: Reserved  0001: field planar YCbCr 420  0010: frame planar YCbCr 420  0011: Reserved  0100: Reserved  0101: field planar YCbCr 420 UV combined  0110: frame planar YCbCr 420 UV combined  0111: Reserved  1000: Reserved  1001: field MB YCbCr 420  1010: frame MB YCbCr 420</p>
--	--	--	---



			1011: Reserved 1100: Reserved 1101: field planar YCbCr 420 10bit UV combined 1110: Reserved 1111: Reserved  Others: reserved
15:14	/	/	/
13	R/W	0	<b>VFLIP_EN</b> Vertical flip enable When enabled, the received data will be arranged in vertical flip. 0:Disable 1:Enable
12	R/W	0	<b>HFLIP_EN</b> Horizontal flip enable When enabled, the received data will be arranged in horizontal flip. 0:Disable 1:Enable
11:10	R/W	0	<b>FIELD_SEL</b> Field selection. 00: capturing with field 1. 01: capturing with field 2. 10: capturing with either field. 11: reserved
09:08	R/W	2	<b>INPUT_SEQ</b> Input data sequence, only valid for YUV422 and YUV420 input format. All data interleaved in one channel: 00: YUYV 01: YVYU 10: UYVY 11: VYUY Y and UV in separated channel: x0: UV x1: VU
07:02	/	/	/
01:00	R/W	0	<b>MIN_SDR_WR_SIZE</b> Minimum size of SDRAM block write 0: 256 bytes (if hflip is enable, always select 256 bytes) 1: 512 bytes 2: 1k bytes 3: 2k bytes

**6.1.4.10. CSI Channel\_0 scale Register (Default Value: 0x00000000)**

Offset: 0x004C			Register Name: <b>CSIO_CO_SCALE_REG</b>
Bit	R/W	Default/Hex	Description
31:01	/	/	/
00	R/W	0	QUART_EN When this bit is set to 1, input image will be decimated to quarter size. All input format are supported.

**6.1.4.11. CSI Channel\_0 FIFO 0 output buffer-A address Register (Default Value: 0x00000000)**

Offset: 0x0050			Register Name: <b>CSIO_CO_F0_BUFA_REG</b>
Bit	R/W	Default/Hex	Description
31:00	R/W	0	COF0_BUFA FIFO 0 output buffer-A address

**6.1.4.12. CSI Channel\_0 FIFO 1 output buffer-A address Register (Default Value: 0x00000000)**

Offset: 0x0058			Register Name: <b>CSIO_CO_F1_BUFA_REG</b>
Bit	R/W	Default/Hex	Description
31:00	R/W	0	COF1_BUFA FIFO 1 output buffer-A address

**6.1.4.13. CSI Channel\_0 FIFO 2 output buffer-A address Register (Default Value: 0x00000000)**

Offset: 0x0060			Register Name: <b>CSIO_CO_F2_BUFA_REG</b>
Bit	R/W	Default/Hex	Description
31:00	R/W	0	COF2_BUFA FIFO 2 output buffer-A address

**6.1.4.14. CSI Channel\_0 status Register (Default Value: 0x00000000)**

Offset: 0x006C			Register Name: <b>CSIO_CO_CAP_STA_REG</b>
Bit	R/W	Default/Hex	Description
31:03	/	/	/
02	R	0	FIELD_STA The status of the received field 0: Field 0 1: Field 1

01	R	0	<p>VCAP_STA</p> <p>Video capture in progress</p> <p>Indicates the CSI is capturing video image data (multiple frames). The bit is set at the start of the first frame after enabling video capture. When software disables video capture, it clears itself after the last pixel of the current frame is captured.</p>
00	R	0	<p>SCAP_STA</p> <p>Still capture in progress</p> <p>Indicates the CSI is capturing still image data (single frame). The bit is set at the start of the first frame after enabling still frame capture. It clears itself after the last pixel of the first frame is captured.</p> <p>For CCIR656 interface, if the output format is frame planar YCbCr 420 mode, the frame end means the field2 end, the other frame end means filed end.</p>

**6.1.4.15. CSI Channel\_0 interrupt enable Register (Default Value: 0x00000000)**

Offset: 0x0070			Register Name: CSIO_CO_INT_EN_REG
Bit	R/W	Default/Hex	Description
31:08	/	/	/
07	R/W	0	<p>VS_INT_EN</p> <p>vsync flag</p> <p>The bit is set when vsync come. And at this time load the buffer address for the coming frame. So after this irq come, change the buffer address could only effect next frame</p>
06	R/W	0	<p>HB_OF_INT_EN</p> <p>Hblank FIFO overflow</p> <p>The bit is set when 3 FIFOs still overflow after the hblank.</p>
05	R/W	0	<p>MUL_ERR_INT_EN</p> <p>Multi-channel writing error</p> <p>Indicates error has been detected for writing data to a wrong channel.</p>
04	R/W	0	<p>FIFO2_OF_INT_EN</p> <p>FIFO 2 overflow</p> <p>The bit is set when the FIFO 2 become overflow.</p>
03	R/W	0	<p>FIFO1_OF_INT_EN</p> <p>FIFO 1 overflow</p> <p>The bit is set when the FIFO 1 become overflow.</p>
02	R/W	0	<p>FIFO0_OF_INT_EN</p> <p>FIFO 0 overflow</p> <p>The bit is set when the FIFO 0 become overflow.</p>
01	R/W	0	<p>FD_INT_EN</p> <p>Frame done</p> <p>Indicates the CSI has finished capturing an image frame. Applies to video capture mode. The bit is set after each completed frame capturing data is wrote to buffer as long as video capture remains enabled.</p>

00	R/W	0	<p>CD_INT_EN</p> <p>Capture done</p> <p>Indicates the CSI has completed capturing the image data.</p> <p>For still capture, the bit is set when one frame data has been wrote to buffer.</p> <p>For video capture, the bit is set when the last frame has been wrote to buffer after video capture has been disabled.</p> <p>For CCIR656 interface, if the output format is frame planar YCbCr 420 mode, the frame end means the field2 end, the other frame end means field end.</p>
----	-----	---	---

**6.1.4.16. CSI Channel\_0 interrupt status Register (Default Value: 0x00000000)**

Offset: 0x0074			Register Name: <b>CSIO_CO_INT_STA_REG</b>
Bit	R/W	Default/Hex	Description
31:08	/	/	/
07	R/W	0	VS_PD vsync flag
06	R/W	0	HB_OF_PD Hblank FIFO overflow
05	R/W	0	MUL_ERR_PD Multi-channel writing error
04	R/W	0	FIFO2_OF_PD FIFO 2 overflow
03	R/W	0	FIFO1_OF_PD FIFO 1 overflow
02	R/W	0	FIFO0_OF_PD FIFO 0 overflow
01	R/W	0	FD_PD Frame done
00	R/W	0	CD_PD Capture done

**6.1.4.17. CSI Channel\_0 horizontal size Register (Default Value: 0x05000000)**

Offset: 0x0080			Register Name: <b>CSIO_CO_INT_STA_REG</b>
Bit	R/W	Default/Hex	Description
31:29	/	/	/
28:16	R/W	500	HOR_LEN Horizontal pixel unit length. Valid pixel of a line.
15:13	/	/	/
12:00	R/W	0	HOR_START Horizontal pixel unit start. Pixel is valid from this pixel.

**6.1.4.18. CSI Channel\_0 vertical size Register (Default Value: 0x01E00000)**

Offset: 0x0084			Register Name: <b>CSIO_CO_VSIZE_REG</b>
Bit	R/W	Default/Hex	Description
31:29	/	/	/
28:16	R/W	1E0	VER_LEN Vertical line length. Valid line number of a frame.
15:13	/	/	/
12:00	R/W	0	VER_START Vertical line start. data is valid from this line.

**6.1.4.19. CSI Channel\_0 buffer length Register (Default Value: 0x01400280)**

Offset: 0x0088			Register Name: <b>CSIO_CO_BUF_LEN_REG</b>
Bit	R/W	Default/Hex	Description
31:30	/	/	/
29:16	R/W	140	BUF_LEN_C Buffer length of chroma C in a line. Unit is byte.
15:14	/	/	/
13:00	R/W	280	BUF_LEN Buffer length of luminance Y in a line. Unit is byte.

**6.1.4.20. CSI Channel\_0 flip size Register (Default Value: 0x01E00280)**

Offset: 0x008C			Register Name: <b>CSIO_CO_FLIP_SIZE_REG</b>
Bit	R/W	Default/Hex	Description
31:29	/	/	/
28:16	R/W	1E0	VER_LEN Vertical line number when in vflip mode.
15:13	/	/	/
12:00	R/W	280	VALID_LEN Valid components of a line when in flip mode.

**6.1.4.21. CSI Channel\_0 frame clock counter Register (Default Value: 0x00000000)**

Offset: 0x0090			Register Name: <b>CSIO_CO_FRM_CLK_CNT_REG</b>
Bit	R/W	Default/Hex	Description
31:24	/	/	/

23:00	R	0	<b>FRM_CLK_CNT</b> Counter value between every frame. For instant hardware frame rate statics. The internal counter is added by one every 24MHz clock cycle. When frame done or vsync comes, the internal counter value is sampled to FRM_CLK_CNT, and cleared to 0.
-------	---	---	--

**6.1.4.22. CSI Channel\_0 accumulated and internal clock counter Register (Default Value: 0x00000000)**

Offset: 0x0094			Register Name: <b>CSIO_CO_ACC_ITNL_CLK_CNT_REG</b>
Bit	R/W	Default/Hex	Description
31:24	R	0	<b>ACC_CLK_CNT</b> The accumulated value of FRM_CLK_CNT for software frame rate statics. Every interrupt of frame done, the software check this accumulated value and clear it to 0. If the ACC_CLK_CNT is larger than 1, the software has lost frame. When frame done or vsync comes, ACC_CLK_CNT = ACC_CLK_CNT + 1, and cleared to 0 when writing 0 to this register.
23:00	R	0	<b>ITNL_CLK_CNT</b> The instant value of internal frame clock counter. When frame done interrupt comes, the software can query this counter for judging whether it is the time for updating the double buffer address registers.

**6.1.4.23. CSI Channel\_0 FIFO Statistic Register (Default Value: 0x00000000)**

Offset: 0x0098			Register Name: <b>CSIO_CO_FIFO_STAT_REG</b>
Bit	R/W	Default/Hex	Description
31:12	/	/	/
11:00	R	0	<b>FIFO_FRM_MAX</b> Indicates the maximum depth of FIFO being occupied for whole frame. Update at every vsync or framedone.

**6.1.4.24. CSI Channel\_0 PCLK Statistic Register (Default Value: 0x00007FFF)**

Offset: 0x009C			Register Name: <b>CSIO_CO_PCLK_STAT_REG</b>
Bit	R/W	Default/Hex	Description
31	/	/	/
30:16	R	0	<b>PCLK_CNT_LINE_MAX</b> Indicates maximum pixel clock counter value for each line. Update at every vsync or framedone.

15	/	/	/
14:00	R	0x7fff	PCLK_CNT_LINE_MIN Indicates minimum pixel clock counter value for each line. Update at every vsync or framedone.

#### 6.1.4.25. CCI Control Register (Default Value: 0x00000000)

Offset: 0x3000			Register Name: CCI_CTRL_REG
Bit	R/W	Default/Hex	Description
31	R/W	0	SINGLE_TRAN 0: Transmission idle 1: Start single transmission Automatically cleared to '0' when finished. Abort current transmission immediately if changing from '1' to '0'. If slave not respond for the expected status over the time defined by TIMEOUT, current transmission will stop. PACKET_CNT will return the sequence number when transmission fail. All format setting and data will be loaded from registers and FIFO when transmission start.
30	R/W	0	REPEAT_TRAN 0: transmission idle 1: repeated transmission When this bit is set to 1, transmission repeats when trigger signal (such as VSYNC/ VCAP done ) repeats. If changing this bit from '1' to '0' during transmission, the current transmission will be guaranteed then stop.
29	R/W	0	RESTART_MODE 0: RESTART 1: STOP+START Define the CCI action after sending register address.
28	R/W	0	READ_TRAN_MODE 0: send slave_id+W 1: do not send slave_id+W <b>Note:Setting this bit to 1 if reading from a slave which register width is equal to 0.</b>
27:24	R	0	TRAN_RESULT 000: OK 001: FAIL Other: Reserved
23:16	R	/	CCI_STA 0x00: bus error 0x08: START condition transmitted 0x10: Repeated START condition transmitted 0x18: Address + Write bit transmitted, ACK received 0x20: Address + Write bit transmitted, ACK not received

			0x28: Data byte transmitted in master mode, ACK received 0x30: Data byte transmitted in master mode, ACK not received 0x38: Arbitration lost in address or data byte 0x40: Address + Read bit transmitted, ACK received 0x48: Address + Read bit transmitted, ACK not received 0x50: Data byte received in master mode, ACK received 0x58: Data byte received in master mode, ACK not received 0x01: Timeout when sending 9th SCL clk Other: Reserved
15:2	/	/	/
1	R/W	0	SOFT_RESET 0: normal 1: reset
0	R/W	0	CCI_EN 0: Module disable 1: Module enable

#### 6.1.4.26. CCI Transmission Configuration Register (Default Value: 0x10000000)

Offset: 0x3004			Register Name: CCI_CFG_REG
Bit	R/W	Default/Hex	Description
31:24	R/W	0x10	TIMEOUT_N When sending the 9th clock, assert fail signal when slave device did not response after N*FSCL cycles. And software must do a reset to CCI module and send a stop condition to slave.
23:16	R/W	0x00	INTERVAL Define the interval between each packet in 40*FSCL cycles. 0~255
15	R/W	0	PACKET_MODE Select where to load slave id / data width 0: Compact mode 1: Complete mode In compact mode, slave id/register width / data width will be loaded from CCI_FMT register, only address and data read from memory. In complete mode, they will be loaded from packet memory.
14:7	/	/	/
6:4	R/W	0	TRIG_MODE Transmit mode: 000: Immediately, no trigger 001: Reserved 010: CSI0 int trigger 011: CSI1 int trigger
3:0	R/W	0	CSI_TRIG CSI Int trig signal select: 0000: First HREF start



			0001: Last HREF done 0010: Line counter trigger other: Reserved
--	--	--	---

#### 6.1.4.27. CCI Packet Format Register (Default Value: 0x00110001)

Offset: 0x3008			Register Name: CCI_FMT_REG
Bit	R/W	Default/Hex	Description
31:25	R/W	0	SLV_ID 7bit address
24	R/W	0	CMD 0: write 1: read
23:20	R/W	1	ADDR_BYTE How many bytes be sent as address 0~15
19:16	R/W	1	DATA_BYTE How many bytes be sent/received as data 1~15 Normally use ADDR_DATA with 0_2, 1_1, 1_2, 2_1, 2_2 access mode. If DATA bytes is 0, transmission will not start. In complete mode, the ADDR_BYTE and DATA_BYTE is defined in a byte's high/low 4bit.
15:0	R/W	1	PACKET_CNT FIFO data be transmitted as PACKET_CNT packets in current format. Total bytes not exceed 32bytes.

#### 6.1.4.28. CCI Bus Control Register (Default Value: 0x00002500)

Offset: 0x300C			Register Name: CCI_BUS_REG
Bit	R/W	Default/Hex	Description
31:16	R/W	0	DLY_CYC 0~65535 FSCL cycles between each transmission
15	R/W	0	DLY_TRIG 0: disable 1: execute transmission after internal counter delay when triggered
14:12	R/W	0x2	CLK_N CCI bus sampling clock $F_0=24\text{MHz}/2^{\text{CLK\_N}}$
11:8	R/W	0x5	CLK_M CCI output SCL frequency is $\text{FSCL}=F_1/10=(F_0/(\text{CLK\_M}+1))/10$
7	R	/	SCL_STA SCL current status
6	R	/	SDA_STA

			SDA current status
5	R/W	0	SCL_PEN SCL PAD enable
4	R/W	0	SDA_PEN SDA PAD enable
3	R/W	0	SCL_MOV SCL manual output value
2	R/W	0	SDA_MOV SDA manual output value
1	R/W	0	SCL_MOE SCL manual output en
0	R/W	0	SDA_MOE SDA manual output en

#### 6.1.4.29. CCI Interrupt Control Register (Default Value: 0x00000000)

Offset: 0x3014			Register Name: <b>CCI_INT_CTRL_REG</b>
Bit	R/W	Default/Hex	Description
31:18	/	/	/
17	R/W	0	S_TRAN_ERR_INT_EN
16	R/W	0	S_TRAN_COM_INT_EN
15:2	/	/	/
1	R/W	0	S_TRAN_ERR_PD
0	R/W	0	S_TRAN_COM_PD

#### 6.1.4.30. CCI Line Counter Trigger Control Register (Default Value: 0x00000000)

Offset: 0x3018			Register Name: <b>CCI_LC_REG</b>
Bit	R/W	Default/Hex	Description
31:13	/	/	/
12:0	R/W	0	LN_CNT 0~8191: line counter send trigger when 1st~8192th line is received.

#### 6.1.4.31. CCI FIFO Access Register (Default Value: 0x00000000)

Offset: 0x3100~0x313f			Register Name: <b>CCI_FIFO_ACC_REG</b>
Bit	R/W	Default/Hex	Description
31:0	R/W	0	DATA_FIFO From 0x100 to 0x13f, CCI data fifo is 64bytes, used in fifo input mode. CCI transmission read/write data from/to fifo in byte.

# Chapter 7 Display

This chapter describes the H3 display system from following perspectives:

- DE2.0
- TCON

The following figure shows the block diagram of display system:

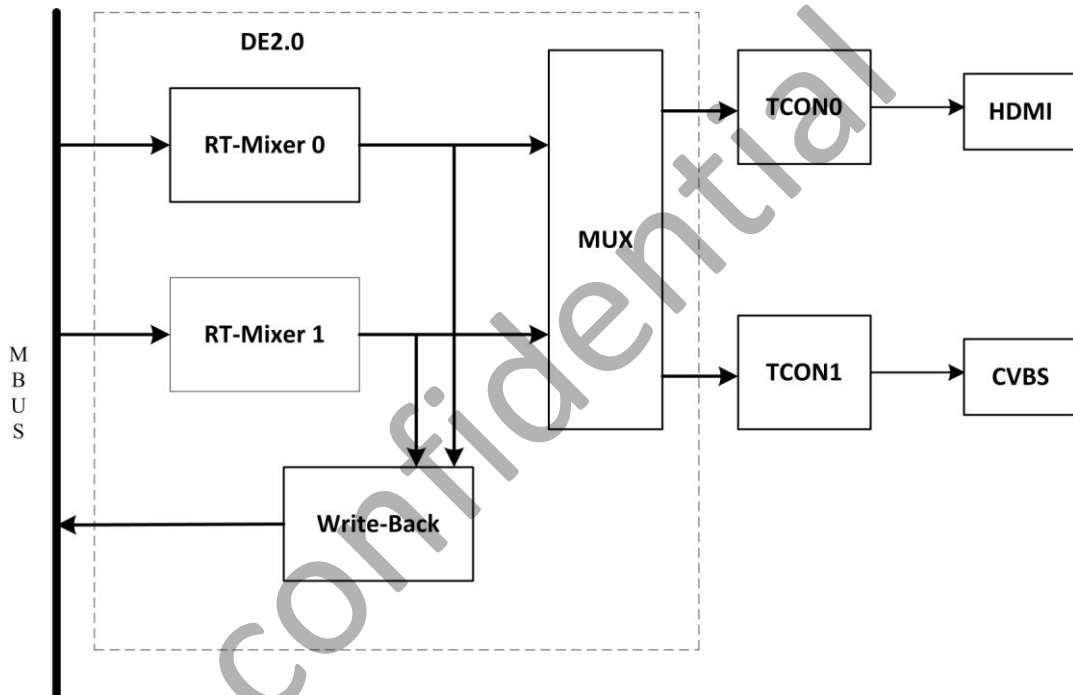

Figure 7-1. Display System Block Diagram

## 7.1. DE2.0

### 7.1.1. Overview

- Output size up to 4096x4096
- Support four alpha blending channel for main display, two channel for aux display
- Support four overlay layers in each channel, and has a independent scaler
- Support potter-duff compatible blending operation
- Support input format YUV422/YUV420/YUV411/ARGB8888/XRGB8888/RGB888/ARGB4444/ARGB1555 and RGB565
- Support Frame Packing/Top-and-Bottom/Side-by-side Full/Side-by-Side Half 3D format data
- Support SmartColor 2.0 for excellent display experience
  - Adaptive edge sharpening
  - Adaptive color enhancement
  - Adaptive contrast enhancement and fresh tone rectify
- Support writeback for high efficient dual display

Confidential

## 7.2. TCON

### 7.2.1. Overview

The LCD0 module is used for HDMI, and LCD1 module is used for TV.

- Support HDMI interface, up to 1080P
- Support TV interface, up to 480P/576P
- 2 interrupts for programmer single TCON output

### 7.2.2. Block Diagram

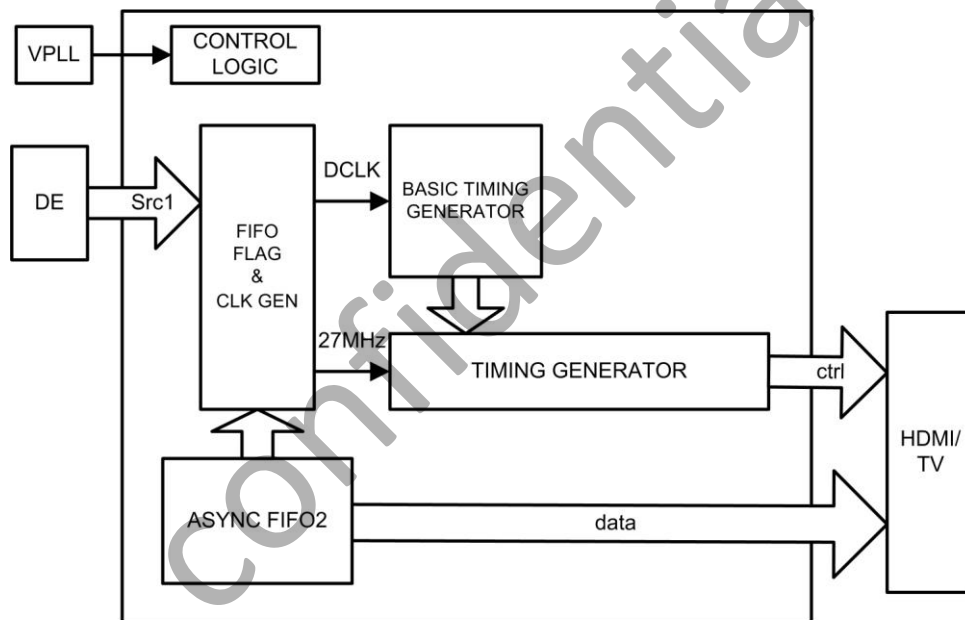

Figure 7-2. TCON Block Diagram

### 7.2.3. Functionalities Description

#### 7.2.3.1. RGB gamma correction

Function: This module correct the RGB input data of DE0 .

A 256\*8\*3 Byte register file is used to store the gamma table. The following is the layout:

Offset	Value
0x400, 0x401, 0x402	{ B0[7:0], G0[7:0], R0[7:0] }
0x404,	{ B1[7:0], G1[7:0], R1[7:0] }

.....	.....
0x4FC	{ B255[7:0], G255[7:0], R255[7:0] }

### 7.2.3.2. CEU module

Function: This module enhance color data from DE0 .

$$R' = Rr * R + Rg * G + Rb * B + Rc$$

$$G' = Gr * R + Gg * G + Gb * B + Gc$$

$$B' = Br * R + Bg * G + Bb * B + Bc$$

Note:

Rr, Rg, Rb, ,Gr, Gg, Gb, Br, Bg, Bb s13 (-16,16)

Rc, Gc, Bc s19 (-16384, 16384)

R, G, B u8 [0-255]

R' have the range of [Rmin ,Rmax]

G' have the range of [Rmin ,Rmax]

B' have the range of [Rmin ,Rmax]

### 7.2.4. LCD0 Module Register List

Module Name	Base Address
TCON0	0x01C0C000

Register Name	Offset	Description
TCON_GCTL_REG	0x000	TCON global control register
TCON_GINT0_REG	0x004	TCON global interrupt register0
TCON_GINT1_REG	0x008	TCON global interrupt register1
TCON1_CTL_REG	0x090	TCON1 control register
TCON1_BASIC0_REG	0x094	TCON1 basic timing register0
TCON1_BASIC1_REG	0x098	TCON1 basic timing register1
TCON1_BASIC2_REG	0x09C	TCON1 basic timing register2
TCON1_BASIC3_REG	0x0A0	TCON1 basic timing register3
TCON1_BASIC4_REG	0x0A4	TCON1 basic timing register4
TCON1_BASIC5_REG	0x0A8	TCON1 basic timing register5
TCON1_PS_SYNC_REG	0x0B0	TCON1 sync register
TCON1_IO_POL_REG	0x0F0	TCON1 IO polarity register
TCON1_IO_TRI_REG	0x0F4	TCON1 IO control register
TCON_ECC_FIFO_REG	0x0F8	TCON ECC FIFO register
TCON_CEU_CTL_REG	0x100	TCON CEU control register
TCON_CEU_COEF_MUL_REG	0x110+N*0x04	TCON CEU coefficient register0 (N=0,1,2,4,5,6,8,9,10)
TCON_CEU_COEF_ADD_REG	0x11C+N*0x10	TCON CEU coefficient register1 (N=0,1,2)

TCON_CEU_COEF_RANG_REG	0x140+N*0x04	TCON CEU coefficient register2 (N=0,1,2)
TCON_SAFE_PERIOD_REG	0x1F0	TCON safe period register
TCON1_FILL_CTL_REG	0x300	TCON1 fill data control register
TCON1_FILL_BEGIN_REG	0x304+N*0x0C	TCON1 fill data begin register (N=0,1,2)
TCON1_FILL_END_REG	0x308+N*0x0C	TCON1 fill data end register (N=0,1,2)
TCON1_FILL_DATA0_REG	0x30C+N*0x0C	TCON1 fill data value register (N=0,1,2)
TCON1_GAMMA_TABLE_REG	0x400-0x7FF	
TCON_ECC_FIFO_BIST_REG	0xFFC	

### 7.2.5. LCD0 Module Register Description

#### 7.2.5.1. TCON Global Control Register (Default Value: 0x00000000)

Offset: 0x0000			Register Name: <b>TCON_GCTL_REG</b>
Bit	R/W	Default/Hex	Description
31	R/W	0	TCON_En 0: disable 1: enable When it's disabled, the module will be reset to idle state.
30	R/W	0	TCON_Gamma_En 0: disable 1: enable
29:0	/	/	/

#### 7.2.5.2. TCON Global Interrupt Register0 (Default Value: 0x00000000)

Offset: 0x0004			Register Name: <b>TCON_GINT0_REG</b>
Bit	R/W	Default/Hex	Description
31	/	/	/
30	R/W	0	TCON1_Vb_Int_En 0: disable 1: enable
29	/	/	/
28	R/W	0	TCON1_Line_Int_En 0: disable 1: enable
27:15	/	/	/

14	R/W	0	TCON1_Vb_Int_Flag Asserted during vertical no-display period every frame. Write 0 to clear it.
13	/	/	/
12	R/W	0	TCON1_Line_Int_Flag trigger when SY1 match the current TCON1 scan line Write 0 to clear it.
11:0	/	0	/

#### 7.2.5.3. TCON Global Interrupt Register1 (Default Value: 0x00000000)

Offset: 0x0008			Register Name: <b>TCON_GINT1_REG</b>
Bit	R/W	Default/Hex	Description
31:12	/	/	/
11:0	R/W	0	TCON1_Line_Int_Num scan line for TCON1 line trigger(including inactive lines) Setting it for the specified line for trigger1. Note: SY1 is writable only when LINE_TRG1 disable.

#### 7.2.5.4. TCON1 Control Register (Default Value: 0x00000000)

Offset: 0x090			Register Name: <b>TCON1_CTL_REG</b>
Bit	R/W	Default/Hex	Description
31	R/W	0	TCON1_En 0: disable 1: enable
30:9	/	/	/
8:4	R/W	0	Start_Delay This is for DE1 and DE2
3:2	/	/	/
1	R/W	0	TCON1_Src_Sel 0: reserved 1: BLUE data(FIFO2 disable, RGB=0000FF)
0	/	/	/

#### 7.2.5.5. TCON1 Basic Timing Register0 (Default Value: 0x00000000)

Offset: 0x094			Register Name: <b>TCON1_BASIC0_REG</b>
Bit	R/W	Default/Hex	Description
31:28	/	/	/
27:16	R/W	0	TCON1_XI



			source width is X+1
15:12	/	/	/
11:0	R/W	0	TCON1_YI source height is Y+1

**7.2.5.6. TCON1 Basic Timing Register1 (Default Value: 0x00000000)**

Offset: 0x098			Register Name: <b>TCON1_BASIC1_REG</b>
Bit	R/W	Default/Hex	Description
31:28	/	/	/
27:16	R/W	0	LS_XO width is LS_XO+1
15:12	/	/	/
11:0	R/W	0	LS_YO width is LS_YO+1 <b>NOTE:</b> This version LS_YO = TCON1_YI

**7.2.5.7. TCON1 Basic Timing Register2 (Default Value: 0x00000000)**

Offset: 0x09C			Register Name: <b>TCON1_BASIC2_REG</b>
Bit	R/W	Default/Hex	Description
31:28	/	/	/
27:16	R/W	0	TCON1_XO width is TCON1_XO+1
15:12	/	/	/
11:0	R/W	0	TCON1_YO height is TCON1_YO+1

**7.2.5.8. TCON1 Basic Timing Register3 (Default Value: 0x00000000)**

Offset: 0x0A0			Register Name: <b>TCON1_BASIC3_REG</b>
Bit	R/W	Default/Hex	Description
31:29	/	/	/
28:16	R/W	0	HT horizontal total time $Thcycle = (HT+1) * Thdclk$
15:12	/	/	/
11:0	R/W	0	HBP horizontal back porch $Thbp = (HBP +1) * Thdclk$

**7.2.5.9. TCON1 Basic Timing Register4 (Default Value: 0x00000000)**

Offset: 0x0A4			Register Name: TCON1_BASIC4_REG
Bit	R/W	Default/Hex	Description
31:29	/	/	/
28:16	R/W	0	VT horizontal total time (in HD line) $T_{vt} = VT/2 * Th$
15:12	/	/	/
11:0	R/W	0	VBP horizontal back porch (in HD line) $T_{vbp} = (VBP + 1) * Th$

**7.2.5.10. TCON1 Basic Timing Register5 (Default Value: 0x00000000)**

Offset: 0x0A8			Register Name: TCON1_BASIC5_REG
Bit	R/W	Default/Hex	Description
31:26	/	/	/
25:16	R/W	0	HSPW horizontal Sync Pulse Width (in dclk) $T_{hspw} = (HSPW+1) * T_{dclk}$ Note: $HT > (HSPW+1)$
15:10	/	/	/
9:0	R/W	0	VSPW vertical Sync Pulse Width (in lines) $T_{vspw} = (VSPW+1) * Th$ Note: $VT/2 > (VSPW+1)$

**7.2.5.11. TCON CEU Control Register (Default Value: 0x00000000)**

Offset: 0x100			Register Name: TCON_CEU_CTL_REG
Bit	R/W	Default/Hex	Description
31	R/W	0	CEU_en 0: bypass 1: enable
30:0	/	/	/

**7.2.5.12. TCON CEU Coefficient Mul Register (Default Value: 0x00000000)**

Offset: 0x110+N*0x04			Register Name: TCON_CEU_COEF_REG
----------------------	--	--	----------------------------------

(N=0,1,2,4,5,6,8,9,10)			
Bit	R/W	Default/Hex	Description
31:13	/	/	/
12:0	R/W	0	CEU_Coef_Mul_Value signed 13bit value, range of (-16,16) N=0: Rr N=1: Rg N=2: Rb N=4: Gr N=5: Gg N=6: Gb N=8: Br N=9: Bg N=10: Bb

**7.2.5.13. TCON CEU Coefficient Add Register (Default Value: 0x00000000)**

Offset: 0x11C+N*0x10 (N=0,1,2)			Register Name: TCON_CEU_COEF_ADD_REG
Bit	R/W	Default/Hex	Description
31:19	/	/	/
18:0	R/W	0	CEU_Coef_Add_Value signed 19bit value, range of (-16384, 16384) N=0: Rc N=1: Gc N=2: Bc

**7.2.5.14. TCON CEU Coefficient Range Register (Default Value: 0x00000000)**

Offset: 0x140+N*0x04 (N=0,1,2)			Register Name: TCON_CEU_COEF_RANGE_REG
Bit	R/W	Default/Hex	Description
31:24	/	/	/
23:16	R/W	0	CEU_Coef_Range_Min unsigned 8bit value, range of [0,255]
15:8	/	/	/
7:0	R/W	0	CEU_Coef_Range_Max unsigned 8bit value, range of [0,255]

**7.2.5.15. TCON1 Fill Control Register (Default Value: 0x00000000)**

Offset: 0x300			Register Name: <b>TCON1_FILL_CTL_REG</b>
Bit	R/W	Default/Hex	Description
31	R/W	0	TCON1_Fill_En 0: bypass 1: enable
30:0	/	/	/

**7.2.5.16. TCON1 Fill Begin Register (Default Value: 0x00000000)**

Offset: 0x304+N*0x0C (N=0,1,2)			Register Name: <b>TCON1_FILL_BEGIN_REG</b>
Bit	R/W	Default/Hex	Description
31:24	/	/	/
23:0	R/W	0	Fill_Begin

**7.2.5.17. TCON1 Fill End Register (Default Value: 0x00000000)**

Offset: 0x308+N*0x0C (N=0,1,2)			Register Name: <b>TCON1_FILL_END_REG</b>
Bit	R/W	Default/Hex	Description
31:24	/	/	/
23:0	R/W	0	Fill_End

**7.2.5.18. TCON1 Fill Data Register (Default Value: 0x00000000)**

Offset: 0x30C+N*0x0C (N=0,1,2)			Register Name: <b>TCON1_FILL_DATA_REG</b>
Bit	R/W	Default/Hex	Description
31:24	/	/	/
23:0	R/W	0	Fill_Value

**7.2.6. LCD1 Module Register List**

Module Name	Base Address
TCON1	0x01C0D000

Register Name	Offset	Description
---------------	--------	-------------

TCON_GCTL_REG	0x000	TCON global control register
TCON_GINT0_REG	0x004	TCON global interrupt register0
TCON_GINT1_REG	0x008	TCON global interrupt register1
TCON1_CTL_REG	0x090	TCON1 control register
TCON1_BASIC0_REG	0x094	TCON1 basic timing register0
TCON1_BASIC1_REG	0x098	TCON1 basic timing register1
TCON1_BASIC2_REG	0x09C	TCON1 basic timing register2
TCON1_BASIC3_REG	0x0A0	TCON1 basic timing register3
TCON1_BASIC4_REG	0x0A4	TCON1 basic timing register4
TCON1_BASIC5_REG	0x0A8	TCON1 basic timing register5
TCON1_PS_SYNC_REG	0x0B0	TCON1 sync register
TCON1_IO_POL_REG	0x0F0	TCON1 IO polarity register
TCON1_IO_TRI_REG	0x0F4	TCON1 IO control register
TCON_ECC_FIFO_REG	0x0F8	TCON ECC FIFO register
TCON_CEU_CTL_REG	0x100	TCON CEU control register
TCON_CEU_COEF_MUL_REG	0x110+N*0x04	TCON CEU coefficient register0 (N=0,1,2,4,5,6,8,9,10)
TCON_CEU_COEF_ADD_REG	0x11C+N*0x10	TCON CEU coefficient register1 (N=0,1,2)
TCON_CEU_COEF_RANG_REG	0x140+N*0x04	TCON CEU coefficient register2 (N=0,1,2)
TCON_SAFE_PERIOD_REG	0x1F0	TCON safe period register
TCON1_FILL_CTL_REG	0x300	TCON1 fill data control register
TCON1_FILL_BEGIN_REG	0x304+N*0x0C	TCON1 fill data begin register (N=0,1,2)
TCON1_FILL_END_REG	0x308+N*0x0C	TCON1 fill data end register (N=0,1,2)
TCON1_FILL_DATA0_REG	0x30C+N*0x0C	TCON1 fill data value register (N=0,1,2)
TCON1_GAMMA_TABLE_REG	0x400-0x7FF	
TCON_ECC_FIFO_BIST_REG	0xFFC	

## 7.2.7. LCD1 Module Register Description

### 7.2.7.1. TCON Global Control Register (Default Value: 0x00000000)

Offset: 0x0000			Register Name: <b>TCON_GCTL_REG</b>
Bit	R/W	Default/Hex	Description
31	R/W	0	TCON_En 0: disable 1: enable When it's disabled, the module will be reset to idle state.

30	R/W	0	TCON_Gamma_En 0: disable 1: enable
29:0	/	/	/

**7.2.7.2. TCON Global Interrupt Register0 (Default Value: 0x00000000)**

Offset: 0x0004			Register Name: <b>TCON_GINT0_REG</b>
Bit	R/W	Default/Hex	Description
31	/	/	/
30	R/W	0	TCON1_Vb_Int_En 0: disable 1: enable
29	/	/	/
28	R/W	0	TCON1_Line_Int_En 0: disable 1: enable
27:15	/	/	/
14	R/W	0	TCON1_Vb_Int_Flag Asserted during vertical no-display period every frame. Write 0 to clear it.
13	/	/	/
12	R/W	0	TCON1_Line_Int_Flag trigger when SY1 match the current TCON1 scan line Write 0 to clear it.
11:0	/	0	/

**7.2.7.3. TCON Global Interrupt Register1 (Default Value: 0x00000000)**

Offset: 0x0008			Register Name: <b>TCON_GINT1_REG</b>
Bit	R/W	Default/Hex	Description
31:12	/	/	/
11:0	R/W	0	TCON1_Line_Int_Num scan line for TCON1 line trigger(including inactive lines) Setting it for the specified line for trigger 1. Note: SY1 is writable only when LINE_TRG1 disable.

**7.2.7.4. TCON1 Control Register (Default Value: 0x00000000)**

Offset: 0x0090			Register Name: <b>TCON1_CTL_REG</b>
Bit	R/W	Default/Hex	Description

31	R/W	0	TCON1_En 0: disable 1: enable
30:9	/	/	/
8:4	R/W	0	Start_Delay This is for DE1 and DE2
3:2	/	/	/
1	R/W	0	TCON1_Src_Sel 00: DE 0 01: BLUE data(FIFO2 disable,RGB = 0000FF)
0	/	/	/

**7.2.7.5. TCON1 Basic Timing Register0 (Default Value: 0x00000000)**

Offset: 0x0094			Register Name: <b>TCON1_BASIC0_REG</b>
Bit	R/W	Default/Hex	Description
31:28	/	/	/
27:16	R/W	0	TCON1_XI source width is X+1
15:12	/	/	/
11:0	R/W	0	TCON1_YI source height is Y+1

**7.2.7.6. TCON1 Basic Timing Register1 (Default Value: 0x00000000)**

Offset: 0x0098			Register Name: <b>TCON1_BASIC1_REG</b>
Bit	R/W	Default/Hex	Description
31:28	/	/	/
27:16	R/W	0	LS_XO width is LS_XO+1
15:12	/	/	/
11:0	R/W	0	LS_YO width is LS_YO+1 NOTE: this version LS_YO = TCON1_YI

**7.2.7.7. TCON1 Basic Timing Register2 (Default Value: 0x00000000)**

Offset: 0x009C			Register Name: <b>TCON1_BASIC2_REG</b>
Bit	R/W	Default/Hex	Description
31:28	/	/	/
27:16	R/W	0	TCON1_XO

			width is TCON1_XO+1
15:12	/	/	/
11:0	R/W	0	TCON1_YO height is TCON1_YO+1

**7.2.7.8. TCON1 Basic Timing Register3 (Default Value: 0x00000000)**

Offset: 0x00A0			Register Name: <b>TCON1_BASIC3_REG</b>
Bit	R/W	Default/Hex	Description
31:29	/	/	/
28:16	R/W	0	HT horizontal total time $T_{hcycle} = (HT+1) * Thdclk$
15:12	/	/	/
11:0	R/W	0	HBP horizontal back porch $T_{hbp} = (HBP +1) * Thdclk$

**7.2.7.9. TCON1 Basic Timing Register (Default Value: 0x00000000)**

Offset: 0x00A4			Register Name: <b>TCON1_BASIC4_REG</b>
Bit	R/W	Default/Hex	Description
31:29	/	/	/
28:16	R/W	0	VT horizontal total time (in HD line) $T_{vt} = VT/2 * Th$
15:12	/	/	/
11:0	R/W	0	VBP horizontal back porch (in HD line) $T_{vbp} = (VBP +1) * Th$

**7.2.7.10. TCON1 Basic Timing Register5 (Default Value: 0x00000000)**

Offset: 0x00A8			Register Name: <b>TCON1_BASIC5_REG</b>
Bit	R/W	Default/Hex	Description
31:29	/	/	/
25:16	R/W	0	HSPW horizontal Sync Pulse Width (in dclk) $T_{hspw} = (HSPW+1) * Tdclk$ Note: $HT > (HSPW+1)$
15:10	/	/	/



9:0	R/W	0	VSPW vertical Sync Pulse Width (in lines) $Tv_{spw} = (VSPW+1) * Th$ Note: $VT/2 > (VSPW+1)$
-----	-----	---	---

**7.2.7.11. TCON CEU Control Register (Default Value: 0x00000000)**

Offset: 0x0100			Register Name: <b>TCON_CEU_CTL_REG</b>
Bit	R/W	Default/Hex	Description
31	R/W	0	CEU_en 0: bypass 1: enable
30:0	/	/	/

**7.2.7.12. TCON CEU Coefficient Mul Register (Default Value: 0x00000000)**

Offset: 0x0110+N*0x04 (N=0,1,2,4,5,6,8,9,10)			Register Name: <b>TCON_CEU_COEF_MUL_REG</b>
Bit	R/W	Default/Hex	Description
31:13	/	/	/
12:0	R/W	0	CEU_Coef_Mul_Value signed 13bit value, range of (-16,16) N=0: Rr N=1: Rg N=2: Rb N=4: Gr N=5: Gg N=6: Gb N=8: Br N=9: Bg N=10: Bb

**7.2.7.13. TCON CEU Coefficient Add Register (Default Value: 0x00000000)**

Offset: 0x011C+N*0x10 (N=0,1,2)			Register Name: <b>TCON_CEU_COEF_ADD_REG</b>
Bit	R/W	Default/Hex	Description
31:19	/	/	/
18:0	R/W	0	CEU_Coef_Add_Value signed 19bit value, range of (-16384, 16384) N=0: Rc

			N=1: Gc N=2: Bc
--	--	--	--------------------

**7.2.7.14. TCON CEU Coefficient Mul Register (Default Value: 0x00000000)**

Offset: 0x0140+N*0x4 (N=0,1,2)			Register Name: <b>TCON_CEU_COEF_RANG_REG</b>
Bit	R/W	Default/Hex	Description
31:24	/	/	/
23:16	R/W	0	CEU_Coef_Range_Min unsigned 8bit value, range of [0,255]
15:8	/	/	/
7:0	R/W	0	CEU_Coef_Range_Max unsigned 8bit value, range of [0,255]

**7.2.7.15. TCON1 Fill Control Register (Default Value: 0x00000000)**

Offset: 0x0300			Register Name: <b>TCON1_FILL_CTL_REG</b>
Bit	R/W	Default/Hex	Description
31	R/W	0	TCON1_Fill_En 0: bypass 1: enable
30:0	/	/	/

**7.2.7.16. TCON1 Fill Begin Register (Default Value: 0x00000000)**

Offset: 0x0304+N*0x0C(N=0,1,2)			Register Name: <b>TCON1_FILL_BEGIN_REG</b>
Bit	R/W	Default/Hex	Description
31:24	/	/	/
23:0	R/W	0	Fill_Begin

**7.2.7.17. TCON1 Fill End Register (Default Value: 0x00000000)**

Offset: 0x0308+N*0x0C(N=0,1,2)			Register Name: <b>TCON1_FILL_END_REG</b>
Bit	R/W	Default/Hex	Description
31:24	/	/	/
23:0	R/W	0	Fill_End

**7.2.7.18. TCON1 Fill Data Register (Default Value: 0x00000000)**

Offset: 0x030C+N*0x0C(N=0,1,2)			Register Name: TCON1_FILL_DATA_REG
Bit	R/W	Default/Hex	Description
31:24	/	/	/
23:0	R/W	0	Fill_Value

Confidential

## Chapter 8 Interfaces

This chapter describes the H3 interfaces, including:

- TWI
- SPI
- UART
- CIR receiver
- USB
- I2S/PCM
- OWA
- SCR
- Ethernet MAC
- TSC

Confidential

## 8.1. TWI

### 8.1.1. Overview

This TWI Controller is designed to be used as an interface between CPU host and the serial TWI bus. It can support all the standard TWI transfer, including Slave and Master. The communication to the TWI bus is carried out on a byte-wise basis using interrupt or polled handshaking. This TWI Controller can be operated in standard mode (100K bps) or fast-mode, supporting data rate up to 400K bps. Multiple Masters and 10-bit addressing Mode are supported for this specified application. General Call Addressing is also supported in Slave mode.

The TWI Controller includes the following features:

- Software-programmable for Slave or Master
- Support Repeated START signal
- Multi-master systems supported
- Allow 10-bit addressing with TWI bus
- Performs arbitration and clock synchronization
- Own address and General Call address detection
- Interrupt on address detection
- Support speeds up to 400Kbits/s ('fast mode')
- Allow operation from a wide range of input clock frequencies

### 8.1.2. Timing Diagram

Data transferred are always in a unit of 8-bit (byte), followed by an acknowledge bit. The number of bytes that can be transmitted per transfer is unrestricted. Data is transferred in serial with the MSB first. Between each byte of data transfer, a receiver device will hold the clock line SCL low to force the transmitter into a wait state while waiting the response from microprocessor.

Data transfer with acknowledge is obligatory. The clock line is driven by the master all the time, including the acknowledge-related clock cycle, except for the SCL holding between each bytes. After sending each byte, the transmitter releases the SDA line to allow the receiver to pull down the SDA line and send an acknowledge signal (or leave it high to send a "not acknowledge") to the transmitter.

When a slave receiver doesn't acknowledge the slave address (unable to receive because of no resource available), the data line must be left high by the slave so that the master can then generate a STOP condition to abort the transfer. Slave receiver can also indicate not to want to send more data during a transfer by leave the acknowledge signal high. And the master should generate the STOP condition to abort the transfer.

Below diagram provides an illustration the relation of SDA signal line and SCL signal line on the TWI serial bus.

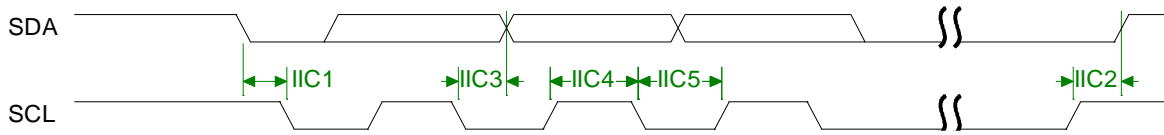

Figure 8-1. TWI Timing Diagram

### 8.1.3. TWI Controller Special Requirement

#### 8.1.3.1. TWI Pin List

Port Name	Width	Direction	Description
TWI_SCL	1	IN/OUT	TWI Clock line
TWI_SDA	1	IN/OUT	TWI Serial Data line

#### 8.1.3.2. TWI Controller Operation

There are four operation modes on the TWI bus which dictates the communications method. They are Master Transmit, Master Receive, Slave Transmit and Slave Receive. In general, CPU host controls TWI by writing commands and data to its registers. The TWI interrupts the CPU host for the attention each time a byte transfer is done or a START/STOP conditions is detected. The CPU host can also poll the status register for current status if the interrupt mechanism is not disabled by the CPU host.

When the CPU host wants to start a bus transfer, it initiates a bus START to enter the master mode by setting IM\_STA bit in the 2WIRE\_CNTR register to high (before it must be low). The TWI will assert INT line and INT\_FLAG to indicate a completion for the START condition and each consequent byte transfer. At each interrupt, the micro-processor needs to check the 2WIRE\_STAT register for current status. A transfer has to be concluded with STOP condition by setting M\_STP bit high.

In Slave Mode, the TWI also constantly samples the bus and look for its own slave address during addressing cycles. Once a match is found, it is addressed and interrupt the CPU host with the corresponding status. Upon request, the CPU host should read the status, read/write 2WIRE\_DATA data register, and set the 2WIRE\_CNTR control register. After each byte transfer, a slave device always halt the operation of remote master by holding the next low pulse on SCL line until the microprocessor responds to the status of previous byte transfer or START condition.

### 8.1.4. TWI Controller Register List

Module Name	Base Address
-------------	--------------

R_TWI	0x01F02400
TWI0	0x01C2AC00
TWI1	0x01C2B000
TWI2	0x01C2B400

Register Name	Offset	Description
TWI_ADDR	0x0000	TWI Slave address
TWI_XADDR	0x0004	TWI Extended slave address
TWI_DATA	0x0008	TWI Data byte
TWI_CNTR	0x000C	TWI Control register
TWI_STAT	0x0010	TWI Status register
TWI_CCR	0x0014	TWI Clock control register
TWI_SRST	0x0018	TWI Software reset
TWI_EFR	0x001C	TWI Enhance Feature register
TWI_LCR	0x0020	TWI Line Control register

### 8.1.5. TWI Controller Register Description

#### 8.1.5.1. TWI Slave Address Register(Default Value: 0x00000000)

Offset: 0x00			Register Name: <b>TWI_ADDR</b>
Bit	R/W	Default/Hex	Description
31:8	/	/	/
7:1	R/W	0	SLA Slave address <ul style="list-style-type: none"> <li>• 7-bit addressing SLA6, SLA5, SLA4, SLA3, SLA2, SLA1, SLA0</li> <li>• 10-bit addressing 1, 1, 1, 1, 0, SLAX[9:8]</li> </ul>
0	R/W	0	GCE General call address enable 0: Disable 1: Enable

**Notes:**

For 7-bit addressing:

SLA6 – SLA0 is the 7-bit address of the TWI when in slave mode. When the TWI receives this address after a START condition, it will generate an interrupt and enter slave mode. (SLA6 corresponds to the first bit received from the TWI bus.) If GCE is set to '1', the TWI will also recognize the general call address (00h).

For 10-bit addressing:

When the address received starts with 11110b, the TWI recognizes this as the first part of a 10-bit address and if the

next two bits match ADDR[2:1] (i.e. SLAX9 and SLAX8 of the device’s extended address), it sends an ACK. (The device does not generate an interrupt at this point.) If the next byte of the address matches the XADDR register (SLAX7 – SLAX0), the TWI generates an interrupt and goes into slave mode.

**8.1.5.2. TWI Extend Address Register(Default Value: 0x00000000)**

Offset: 0x04			Register Name: <b>TWI_XADDR</b>
Bit	R/W	Default/Hex	Description
31:8	/	/	/
7:0	R/W	0	SLAX Extend Slave Address SLAX[7:0]

**8.1.5.3. TWI Data Register(Default Value: 0x00000000)**

Offset: 0x08			Register Name: <b>TWI_DATA</b>
Bit	R/W	Default/Hex	Description
31:8	/	/	/
7:0	R/W	0	TWI_DATA Data byte for transmitting or received

**8.1.5.4. TWI Control Register(Default Value: 0x00000000)**

Offset: 0x0C			Register Name: <b>TWI_CNTR</b>
Bit	R/W	Default/Hex	Description
31:8	/	/	/
7	R/W	0	INT_EN Interrupt Enable 1'b0: The interrupt line always low 1'b1: The interrupt line will go high when INT_FLAG is set.
6	R/W	0	BUS_EN TWI Bus Enable 1'b0: The TWI bus inputs ISDA/ISCL are ignored and the TWI Controller will not respond to any address on the bus 1'b1: The TWI will respond to calls to its slave address – and to the general call address if the GCE bit in the ADDR register is set. Notes: In master operation mode, this bit should be set to '1'
5	R/W	0	M_STA Master Mode Start When M_STA is set to '1', TWI Controller enters master mode and will



			<p>transmit a START condition on the bus when the bus is free. If the M_STA bit is set to '1' when the TWI Controller is already in master mode and one or more bytes have been transmitted, then a repeated START condition will be sent. If the M_STA bit is set to '1' when the TWI is being accessed in slave mode, the TWI will complete the data transfer in slave mode then enter master mode when the bus has been released.</p> <p>The M_STA bit is cleared automatically after a START condition has been sent: writing a '0' to this bit has no effect.</p>
4	R/W	0	<p><b>M_STP</b> Master Mode Stop</p> <p>If M_STP is set to '1' in master mode, a STOP condition is transmitted on the TWI bus. If the M_STP bit is set to '1' in slave mode, the TWI will behave as if a STOP condition has been received, but no STOP condition will be transmitted on the TWI bus. If both M_STA and M_STP bits are set, the TWI will first transmit the STOP condition (if in master mode) then transmit the START condition.</p> <p>The M_STP bit is cleared automatically: writing a '0' to this bit has no effect.</p>
3	R/W	0	<p><b>INT_FLAG</b> Interrupt Flag</p> <p>INT_FLAG is automatically set to '1' when any of 28 (out of the possible 29) states is entered (see 'STAT Register' below). The only state that does not set INT_FLAG is state F8h. If the INT_EN bit is set, the interrupt line goes high when IFLG is set to '1'. If the TWI is operating in slave mode, data transfer is suspended when INT_FLAG is set and the low period of the TWI bus clock line (SCL) is stretched until '1' is written to INT_FLAG. The TWI clock line is then released and the interrupt line goes low.</p>
2	R/W	0	<p><b>A_ACK</b> Assert Acknowledge</p> <p>When A_ACK is set to '1', an Acknowledge (low level on SDA) will be sent during the acknowledge clock pulse on the TWI bus if:</p> <ol style="list-style-type: none"> <li>1. Either the whole of a matching 7-bit slave address or the first or the second byte of a matching 10-bit slave address has been received.</li> <li>2. The general call address has been received and the GCE bit in the ADDR register is set to '1'.</li> <li>3. A data byte has been received in master or slave mode.</li> </ol> <p>When A_ACK is '0', a Not Acknowledge (high level on SDA) will be sent when a data byte is received in master or slave mode.</p> <p>If A_ACK is cleared to '0' in slave transmitter mode, the byte in the DATA register is assumed to be the 'last byte'. After this byte has been transmitted, the TWI will enter state C8h then return to the idle state (status code F8h) when INT_FLAG is cleared.</p> <p>The TWI will not respond as a slave unless A_ACK is set.</p>
1:0	R/W	0	/

**8.1.5.5. TWI Status Register(Default Value: 0x000000F8)**

Offset: 0x10			Register Name: <b>TWI_STAT</b>
Bit	R/W	Default/Hex	Description
31:8	/	/	/
			STA Status Information Byte <b>Code Status</b> 0x00: Bus error 0x08: START condition transmitted 0x10: Repeated START condition transmitted 0x18: Address + Write bit transmitted, ACK received 0x20: Address + Write bit transmitted, ACK not received 0x28: Data byte transmitted in master mode, ACK received 0x30: Data byte transmitted in master mode, ACK not received 0x38: Arbitration lost in address or data byte 0x40: Address + Read bit transmitted, ACK received 0x48: Address + Read bit transmitted, ACK not received 0x50: Data byte received in master mode, ACK transmitted 0x58: Data byte received in master mode, not ACK transmitted 0x60: Slave address + Write bit received, ACK transmitted 0x68: Arbitration lost in address as master, slave address + Write bit received, ACK transmitted 0x70: General Call address received, ACK transmitted 0x78: Arbitration lost in address as master, General Call address received, ACK transmitted 0x80: Data byte received after slave address received, ACK transmitted 0x88: Data byte received after slave address received, not ACK transmitted 0x90: Data byte received after General Call received, ACK transmitted 0x98: Data byte received after General Call received, not ACK transmitted 0xA0: STOP or repeated START condition received in slave mode 0xA8: Slave address + Read bit received, ACK transmitted 0xB0: Arbitration lost in address as master, slave address + Read bit received, ACK transmitted 0xB8: Data byte transmitted in slave mode, ACK received 0xC0: Data byte transmitted in slave mode, ACK not received 0xC8: Last byte transmitted in slave mode, ACK received 0xD0: Second Address byte + Write bit transmitted, ACK received 0xD8: Second Address byte + Write bit transmitted, ACK not received 0xF8: No relevant status information, INT_FLAG=0 Others: Reserved
7:0	R	0xF8	

**8.1.5.6. TWI Clock Register(Default Value: 0x00000000)**

Offset: 0x14			Register Name: <b>TWI_CCR</b>
Bit	R/W	Default/Hex	Description
31:7	/	/	/
6:3	R/W	0	CLK_M
2:0	R/W	0	CLK_N The TWI bus is sampled by the TWI at the frequency defined by F0: $F_{\text{samp}} = F_0 = F_{\text{in}} / 2^{\text{CLK\_N}}$ The TWI OSCL output frequency, in master mode, is $F_1 / 10$ : $F_1 = F_0 / (\text{CLK\_M} + 1)$ $F_{\text{oscl}} = F_1 / 10 = F_{\text{in}} / (2^{\text{CLK\_N}} * (\text{CLK\_M} + 1) * 10)$ For Example: Fin = 48Mhz (APB clock input) For 400kHz full speed 2Wire, CLK_N = 2, CLK_M=2 $F_0 = 48\text{M} / 2^2 = 12\text{Mhz}$ , $F_1 = F_0 / (10 * (2+1)) = 0.4\text{Mhz}$ For 100Khz standard speed 2Wire, CLK_N=2, CLK_M=11 $F_0 = 48\text{M} / 2^2 = 12\text{Mhz}$ , $F_1 = F_0 / (10 * (11+1)) = 0.1\text{Mhz}$

**8.1.5.7. TWI Soft Reset Register(Default Value: 0x00000000)**

Offset: 0x18			Register Name: <b>TWI_SRST</b>
Bit	R/W	Default/Hex	Description
31:1	/	/	/
0	R/W	0	SOFT_RST Soft Reset Write '1' to this bit to reset the TWI and clear to '0' when completing Soft Reset operation.

**8.1.5.8. TWI Enhance Feature Register(Default Value: 0x00000000)**

Offset: 0x1C			Register Name: <b>TWI_EFR</b>
Bit	R/W	Default/Hex	Description
31:2	/	/	/
0:1	R/W	0	DBN Data Byte number follow Read Command Control 0— No Data Byte to be written after read command 1— Only 1 byte data to be written after read command 2— 2 bytes data can be written after read command 3— 3 bytes data can be written after read command

**8.1.5.9. TWI Line Control Register(Default Value: 0x0000\_003A)**

Offset: 0x20			Register Name: <b>TWI_LCR</b>
Bit	R/W	Default/Hex	Description
31:6	/	/	/
5	R	1	SCL_STATE Current state of TWI_SCL 0 – low 1 - high
4	R	1	SDA_STATE Current state of TWI_SDA 0 – low 1 - high
3	R/W	1	SCL_CTL TWI_SCL line state control bit When line control mode is enabled (bit[2] set), value of this bit decide the output level of TWI_SCL 0 – output low level 1 – output high level
2	R/W	0	SCL_CTL_EN TWI_SCL line state control enable When this bit is set, the state of TWI_SCL is control by the value of bit[3]. 0-disable TWI_SCL line control mode 1-enable TWI_SCL line control mode
1	R/W	1	SDA_CTL TWI_SDA line state control bit When line control mode is enabled (bit[0] set), value of this bit decide the output level of TWI_SDA 0 – output low level 1 – output high level
0	R/W	0	SDA_CTL_EN TWI_SDA line state control enable When this bit is set, the state of TWI_SDA is control by the value of bit[1]. 0-disable TWI_SDA line control mode 1-enable TWI_SDA line control mode

**8.1.5.10. TWI DVFS Register(Default Value: 0x00000000)**

Offset: 0x24			Register Name: <b>TWI_DVFSR</b>
Bit	R/W	Default/Hex	Description
31:3	/	/	/
2	R/W	0	MS_PRIORITY CPU and DVFS BUSY set priority select

			0: CPU has higher priority 1: DVFS has higher priority
1	R/W	0	CPU_BUSY_SET CPU Busy set
0	R/W	0	DVFC_BUSY_SET DVFS Busy set

**Notes:**This register is only implemented in TWIO.

Confidential

## 8.2. SPI

### 8.2.1. Overview

The SPI is the Serial Peripheral Interface which allows rapid data communication with fewer software interrupts. It can interface with up to four slave external devices or one single external master. The SPI module contains one 64x8 receiver buffer (RXFIFO) and one 64x8 transmit buffer (TXFIFO). It can work at two modes: Master mode and Slave mode.

The SPI includes the following features:

- Full-duplex synchronous serial interface
- Master/Slave configurable
- Programmable clock granularity
- Four chip selects to support multiple peripherals
- 8-bit wide by 64-entry FIFO for both transmit and receive data
- Polarity and phase of the Chip Select (SPI\_SS) and SPI Clock (SPI\_SCLK) are configurable
- Interrupt or DMA supported
- Support single and dual read mode

### 8.2.2. SPI Timing Diagram

The serial peripheral interface master uses the SPI\_SCLK signal to transfer data in and out of the shift register. Data is clocked using any one of four programmable clock phase and polarity combinations.

During Phase 0, Polarity 0 and Phase 1, Polarity 1 operations, output data changes on the falling clock edge and input data is shifted in on the rising edge.

During Phase 1, Polarity 0 and Phase 0, Polarity 1 operations, output data changes on the rising edges of the clock and is shifted in on falling edges.

The POL defines the signal polarity when SPI\_SCLK is in idle state. The SPI\_SCLK is high level when POL is '1' and it is low level when POL is '0'. The PHA decides whether the leading edge of SPI\_SCLK is used for setup or sample data. The leading edge is used for setup data when PHA is '1' and for sample data when PHA is '0'. The four kind of modes are listed below:

SPI Mode	POL	PHA	Leading Edge	Trailing Edge
0	0	0	Rising, Sample	Falling, Setup
1	0	1	Rising, Setup	Falling, Sample
2	1	0	Falling, Sample	Rising, Setup
3	1	1	Falling, Setup	Rising, Sample

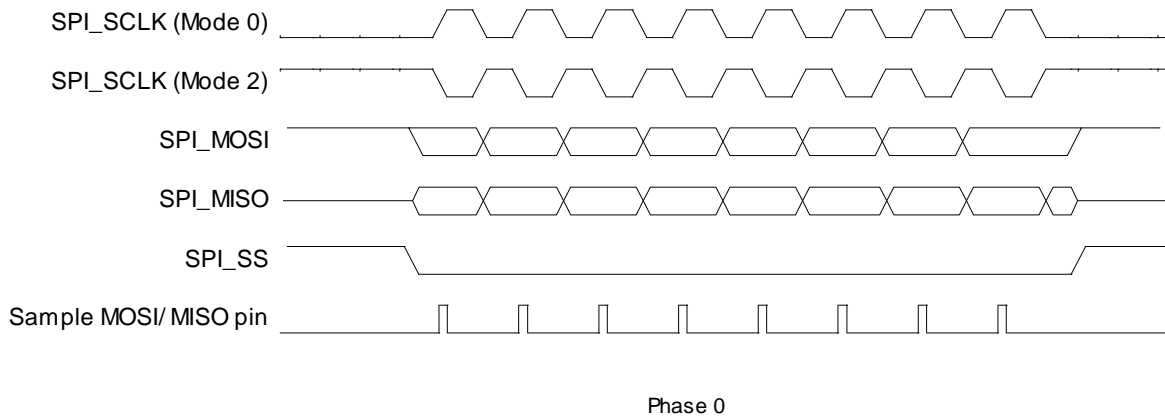

Figure 8-2. SPI Phase 0 Timing Diagram

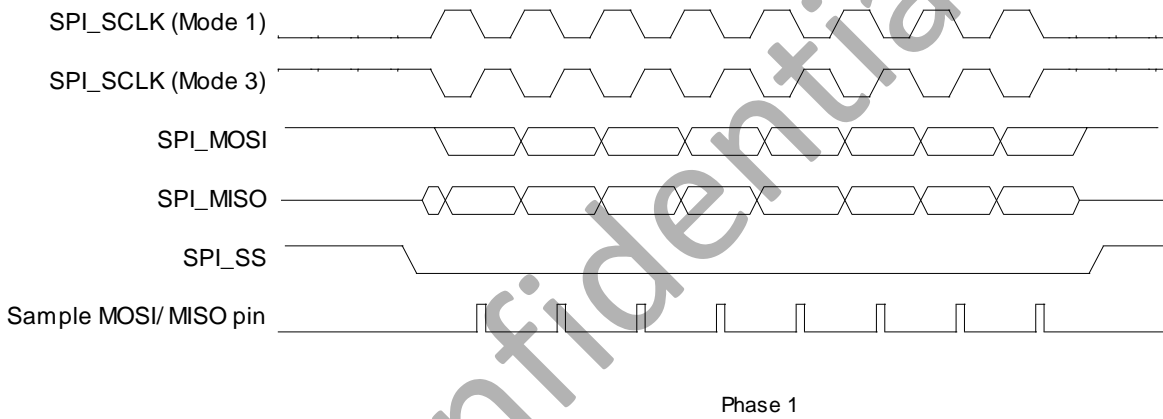

Figure 8-3. SPI Phase 1 Timing Diagram

### 8.2.3. SPI Pin List

The direction of SPI pin is different in two work modes: Master Mode and Slave Mode.

Port Name	Width	Direction(M)	Direction(S)	Description
SPI_SCLK	1	OUT	IN	SPI Clock
SPI_MOSI	1	OUT	IN	SPI Master Output Slave Input Data Signal
SPI_MISO	1	IN	OUT	SPI Master Input Slave Output Data Signal
SPI_SS[3:0]	4	OUT	IN	SPI Chip Select Signal

### 8.2.4. SPI Register List

Module Name	Base Address
-------------	--------------

SPI0	0x01C68000
SPI1	0x01C69000

Register Name	Offset	Description
SPI_GCR	0x04	SPI Global Control Register
SPI_TCR	0x08	SPI Transfer Control register
/	0x0c	reserved
SPI_IER	0x10	SPI Interrupt Control register
SPI_ISR	0x14	SPI Interrupt Status register
SPI_FCR	0x18	SPI FIFO Control register
SPI_FSR	0x1C	SPI FIFO Status register
SPI_WCR	0x20	SPI Wait Clock Counter register
SPI_CCR	0x24	SPI Clock Rate Control register
/	0x28	reserved
/	0x2c	reserved
SPI_MBC	0x30	SPI Burst Counter register
SPI_MTC	0x34	SPI Transmit Counter Register
SPI_BCC	0x38	SPI Burst Control register
SPI_TXD	0x200	SPI TX Data register
SPI_RXD	0x300	SPI RX Data register

## 8.2.5. SPI Register Description

### 8.2.5.1. SPI Global Control Register(Default Value: 0x00000080)

Offset: 0x04			Register Name: SPI_CTL
Bit	R/W	Default/Hex	Description
31	R/W	0	SRST Soft reset Write '1' to this bit will clear the SPI controller, and auto clear to '0' when reset operation completes Write '0' has no effect.
30:8	/	/	/
7	R/W	1	TP_EN Transmit Pause Enable In master mode, it is used to control transmit state machine to stop smart burst sending when RX FIFO is full. 1 – stop transmit data when RXFIFO full 0 – normal operation, ignore RXFIFO status Note: Can't be written when XCH=1
6:2	/	/	/
1	R/W	0	MODE



			SPI Function Mode Select 0: Slave Mode 1: Master Mode Note: Can't be written when XCH=1
0	R/W	0	EN SPI Module Enable Control 0: Disable 1: Enable

**8.2.5.2. SPI Transfer Control Register(Default Value: 0x00000087)**

Offset: 0x08			Register Name: SPI_INTCTL
Bit	R/W	Default/Hex	Description
31	R/W	0x0	XCH Exchange Burst In master mode it is used to start SPI burst 0: Idle 1: Initiates exchange. Write "1" to this bit will start the SPI burst, and will auto clear after finishing the bursts transfer specified by BC. Write "1" to SRST will also clear this bit. Write '0' to this bit has no effect. Note: Can't be written when XCH=1.
30:14	/	/	/
13	R/W	0x0	SDM Master Sample Data Mode 0 - Delay Sample Mode 1 - Normal Sample Mode In Normal Sample Mode, SPI master samples the data at the correct edge for each SPI mode; In Delay Sample Mode, SPI master samples data at the edge that is half cycle delayed by the correct edge defined in respective SPI mode.
12	R/W	0x0	FBS First Transmit Bit Select 0: MSB first 1: LSB first Note: Can't be written when XCH=1.
11	R/W	0x0	SDC Master Sample Data Control Set this bit to '1' to make the internal read sample point with a delay of half cycle of SPI_CLK. It is used in high speed read operation to reduce the error caused by the time delay of SPI_CLK propagating between master and slave. 0 – normal operation, do not delay internal read sample point 1 – delay internal read sample point Note: Can't be written when XCH=1.

10	R/W	0x0	<p>RPSM Rapids mode select Select Rapids mode for high speed write. 0: normal write mode 1: rapids write mode Note: Can't be written when XCH=1.</p>
9	R/W	0x0	<p>DDB Dummy Burst Type 0: The bit value of dummy SPI burst is zero 1: The bit value of dummy SPI burst is one Note: Can't be written when XCH=1.</p>
8	R/W	0x0	<p>DHB Discard Hash Burst In master mode it controls whether discarding unused SPI bursts 0: Receiving all SPI bursts in BC period 1: Discard unused SPI bursts, only fetching the SPI bursts during dummy burst period. The bursts number is specified by TC. Note: Can't be written when XCH=1.</p>
7	R/W	0x1	<p>SS_LEVEL When control SS signal manually (SPI_CTRL_REG.SS_CTRL==1), set this bit to '1' or '0' to control the level of SS signal. 0: set SS to low 1: set SS to high Note: Can't be written when XCH=1.</p>
6	R/W	0x0	<p>SS_OWNER SS Output Owner Select Usually, controller sends SS signal automatically with data together. When this bit is set to 1, software must manually write SPI_CTL_REG.SS_LEVEL to 1 or 0 to control the level of SS signal. 0: SPI controller 1: Software Note: Can't be written when XCH=1.</p>
5:4	R/W	0x0	<p>SS_SEL SPI Chip Select Select one of four external SPI Master/Slave Devices 00: SPI_SS0 will be asserted 01: SPI_SS1 will be asserted 10: SPI_SS2 will be asserted 11: SPI_SS3 will be asserted Note: Can't be written when XCH=1.</p>
3	R/W	0x0	<p>SSCTL In master mode, this bit selects the output wave form for the SPI_SSx signal. Only valid when SS_OWNER = 0. 0: SPI_SSx remains asserted between SPI bursts 1: Negate SPI_SSx between SPI bursts</p>

			Note: Can't be written when XCH=1.
2	R/W	0x1	SPOL SPI Chip Select Signal Polarity Control 0: Active high polarity (0 = Idle) 1: Active low polarity (1 = Idle) Note: Can't be written when XCH=1.
1	R/W	0x1	CPOL SPI Clock Polarity Control 0: Active high polarity (0 = Idle) 1: Active low polarity (1 = Idle) Note: Can't be written when XCH=1.
0	R/W	0x1	CPHA SPI Clock/Data Phase Control 0: Phase 0 (Leading edge for sample data) 1: Phase 1 (Leading edge for setup data) Note: Can't be written when XCH=1.

**8.2.5.3. SPI Interrupt Control Register(Default Value: 0x00000000)**

Offset: 0x10			Register Name: SPI_IER
Bit	R/W	Default/Hex	Description
31:14	R	0x0	Reserved.
13	R/W	0x0	SS_INT_EN SSI Interrupt Enable Chip Select Signal (SSx) from valid state to invalid state 0: Disable 1: Enable
12	R/W	0x0	TC_INT_EN Transfer Completed Interrupt Enable 0: Disable 1: Enable
11	R/W	0x0	TF_UDR_INT_EN TXFIFO under run Interrupt Enable 0: Disable 1: Enable
10	R/W	0x0	TF_OVF_INT_EN TX FIFO Overflow Interrupt Enable 0: Disable 1: Enable
9	R/W	0x0	RF_UDR_INT_EN RXFIFO under run Interrupt Enable 0: Disable 1: Enable
8	R/W	0x0	RF_OVF_INT_EN

			RX FIFO Overflow Interrupt Enable 0: Disable 1: Enable
7	R	0x0	Reserved.
6	R/W	0x0	TF_FUL_INT_EN TX FIFO Full Interrupt Enable 0: Disable 1: Enable
5	R/W	0x0	TX_EMP_INT_EN TX FIFO Empty Interrupt Enable 0: Disable 1: Enable
4	R/W	0x0	TX_ERQ_INT_EN TX FIFO Empty Request Interrupt Enable 0: Disable 1: Enable
3	R	0x0	Reserved
2	R/W	0x0	RF_FUL_INT_EN RX FIFO Full Interrupt Enable 0: Disable 1: Enable
1	R/W	0x0	RX_EMP_INT_EN RX FIFO Empty Interrupt Enable 0: Disable 1: Enable
0	R/W	0x0	RF_RDY_INT_EN RX FIFO Ready Request Interrupt Enable 0: Disable 1: Enable

#### 8.2.5.4. SPI Interrupt Status Register(Default Value: 0x00000022)

Offset: 0x14			Register Name: <b>SPI_INT_STA</b>
Bit	R/W	Default/Hex	Description
31:14	/	0x0	/
13	R/W	0	SSI SS Invalid Interrupt When SSI is 1, it indicates that SS has changed from valid state to invalid state. Writing 1 to this bit clears it.
12	R/W	0	TC Transfer Completed In master mode, it indicates that all bursts specified by BC has been exchanged. In other condition, When set, this bit indicates that all the data in TXFIFO has been loaded in the Shift register, and the Shift register has

			shifted out all the bits. Writing 1 to this bit clears it. 0: Busy 1: Transfer Completed
11	R/W	0	TF_UDF TXFIFO Underrun This bit is set when if the TXFIFO is underrun. Writing 1 to this bit clears it. 0: TXFIFO is not underrun 1: TXFIFO is underrun
10	R/W	0	TF_OVF TXFIFO Overflow This bit is set when if the TXFIFO is overflow. Writing 1 to this bit clears it. 0: TXFIFO is not overflow 1: TXFIFO is overflowed
9	R/W	0	RX_UDF RXFIFO Underrun When set, this bit indicates that RXFIFO has underrun. Writing 1 to this bit clears it.
8	R/W	0	RX_OVF RXFIFO Overflow When set, this bit indicates that RXFIFO has overflowed. Writing 1 to this bit clears it. 0: RXFIFO is available. 1: RXFIFO has overflowed.
7	/	/	/
6	R/W	0	TX_FULL TXFIFO Full This bit is set when if the TXFIFO is full . Writing 1 to this bit clears it. 0: TXFIFO is not Full 1: TXFIFO is Full
5	R/W	1	TX_EMP TXFIFO Empty This bit is set if the TXFIFO is empty. Writing 1 to this bit clears it. 0: TXFIFO contains one or more words. 1: TXFIFO is empty
4	R/W	0	TX_READY TXFIFO Ready 0: TX_WL > TX_TRIG_LEVEL 1: TX_WL <= TX_TRIG_LEVEL This bit is set any time if TX_WL <= TX_TRIG_LEVEL. Writing "1" to this bit clears it. Where TX_WL is the water level of RXFIFO
3	/	/	reserved
2	R/W	0	RX_FULL RXFIFO Full This bit is set when the RXFIFO is full . Writing 1 to this bit clears it. 0: Not Full

			1: Full
1	R/W	1	RX_EMP RXFIFO Empty This bit is set when the RXFIFO is empty . Writing 1 to this bit clears it. 0: Not empty 1: empty
0	R/W	0	RX_RDY RXFIFO Ready 0: RX_WL < RX_TRIG_LEVEL 1: RX_WL >= RX_TRIG_LEVEL This bit is set any time if RX_WL >= RX_TRIG_LEVEL. Writing "1" to this bit clears it. Where RX_WL is the water level of RXFIFO.

### 8.2.5.5. SPI FIFO Control Register(Default Value: 0x00400001)

Offset: 0x18			Register Name: SPI_FCR
Bit	R/W	Default/Hex	Description
31	R/W	0	TX_FIFO_RST TX FIFO Reset Write '1' to this bit will reset the control portion of the TX FIFO and auto clear to '0' when completing reset operation, write to '0' has no effect.
30	R/W	0	TF_TEST_ENB TX Test Mode Enable 0: disable 1: enable Note: In normal mode, TX FIFO can only be read by SPI controller, write '1' to this bit will switch TX FIFO read and write function to AHB bus. This bit is used to test the TX FIFO, don't set in normal operation and don't set RF_TEST and TF_TEST at the same time.
29:26	/	/	/
25	/	/	/
24	R/W	0x0	TF_DRQ_EN TX FIFO DMA Request Enable 0: Disable 1: Enable
23:16	R/W	0x40	TX_TRIG_LEVEL TX FIFO Empty Request Trigger Level
15	R/W	0x0	RF_RST RXFIFO Reset Write '1' to this bit will reset the control portion of the receiver FIFO, and auto clear to '0' when completing reset operation, write '0' to this bit has no effect.
14	R/W	0x0	RF_TEST

			RX Test Mode Enable 0: Disable 1: Enable Note: In normal mode, RX FIFO can only be written by SPI controller, write '1' to this bit will switch RX FIFO read and write function to AHB bus. This bit is used to test the RX FIFO, don't set in normal operation and don't set RF_TEST and TF_TEST at the same time.
13:10	R	0x0	Reserved
9	R/W	0x0	RX_DMA_MODE SPI RX DMA Mode Control 0: Normal DMA mode 1: Dedicate DMA mode
8	R/W	0x0	RF_DRQ_EN RX FIFO DMA Request Enable 0: Disable 1: Enable
7:0	R/W	0x1	RX_TRIG_LEVEL RX FIFO Ready Request Trigger Level

#### 8.2.5.6. SPI FIFO Status Register(Default Value: 0x00000000)

Offset: 0x1C			Register Name: SPI_FSR
Bit	R/W	Default/Hex	Description
31	R	0x0	TB_WR TX FIFO Write Buffer Write Enable
30:28	R	0x0	TB_CNT TX FIFO Write Buffer Counter These bits indicate the number of words in TX FIFO Write Buffer
27:24	R	0x0	Reserved
23:16	R	0x0	TF_CNT TX FIFO Counter These bits indicate the number of words in TX FIFO 0: 0 byte in TX FIFO 1: 1 byte in TX FIFO ... 64: 64 bytes in TX FIFO
15	R	0x0	RB_WR RX FIFO Read Buffer Write Enable
14:12	R	0x0	RB_CNT RX FIFO Read Buffer Counter These bits indicate the number of words in RX FIFO Read Buffer
11:8	R	0x0	Reserved
7:0	R	0x0	RF_CNT RX FIFO Counter

			<p>These bits indicate the number of words in RX FIFO</p> <p>0: 0 byte in RX FIFO</p> <p>1: 1 byte in RX FIFO</p> <p>...</p> <p>64:64 bytes in RX FIFO</p>
--	--	--	--

### 8.2.5.7. SPI Wait Clock Register(Default Value: 0x00000000)

Offset: 0x20			Register Name: <b>SPI_WAIT</b>
Bit	R/W	Default/Hex	Description
31:20	/	/	/
19:16	R/W	0x0	<p>SWC</p> <p>Dual mode direction switch wait clock counter (for master mode only).</p> <p>0: No wait states inserted</p> <p>n: n SPI_SCLK wait states inserted</p> <p>Note: These bits control the number of wait states to be inserted before start dual data transfer in dual SPI mode. The SPI module counts SPI_SCLK by SWC for delaying next word data transfer.</p> <p>Note: Can't be written when XCH=1.</p>
15:0	R/W	0	<p>WCC</p> <p>Wait Clock Counter (In Master mode)</p> <p>These bits control the number of wait states to be inserted in data transfers. The SPI module counts SPI_SCLK by WCC for delaying next word data transfer.</p> <p>0: No wait states inserted</p> <p>N: N SPI_SCLK wait states inserted</p>

### 8.2.5.8. SPI Clock Control Register(Default Value: 0x00000002)

Offset: 0x24			Register Name: <b>SPI_CCTL</b>
Bit	R/W	Default/Hex	Description
31:13	/	/	/
12	R/W	0	<p>DRS</p> <p>Divide Rate Select (Master Mode Only)</p> <p>0: Select Clock Divide Rate 1</p> <p>1: Select Clock Divide Rate 2</p>
11:8	R/W	0	<p>CDR1</p> <p>Clock Divide Rate 1 (Master Mode Only)</p> <p>The SPI_SCLK is determined according to the following equation: SPI_CLK = Source_CLK / 2^n.</p>
7:0	R/W	0x2	<p>CDR2</p> <p>Clock Divide Rate 2 (Master Mode Only)</p>



			The SPI_SCLK is determined according to the following equation: $SPI\_CLK = Source\_CLK / (2 * (n + 1))$ .
--	--	--	--

**8.2.5.9. SPI Master Burst Counter Register(Default Value: 0x00000000)**

Offset: 0x30			Register Name: <b>SPI_BC</b>
Bit	R/W	Default/Hex	Description
31:24	/	/	/
23:0	R/W	0	MBC Master Burst Counter In master mode, this field specifies the total burst number when SMC is 1. 0: 0 burst 1: 1 burst ... N: N bursts

**8.2.5.10. SPI Master Transmit Counter Register(Default Value: 0x00000000)**

Offset: 0x34			Register Name: <b>SPI_TC</b>
Bit	R/W	Default/Hex	Description
31:24	/	/	/
23:0	R/W	0	MWTC Master Write Transmit Counter In master mode, this field specifies the burst number that should be sent to TXFIFO before automatically sending dummy burst when SMC is 1. For saving bus bandwidth, the dummy burst (all zero bits or all one bits) is sent by SPI Controller automatically. 0: 0 burst 1: 1 burst ... N: N bursts

**8.2.5.11. SPI Master Burst Control Counter Register(Default Value: 0x00000000)**

Offset: 0x38			Register Name: <b>SPI_BCC</b>
Bit	R/W	Default/Hex	Description
31:29	R	0x0	Reserved
28	R/W	0x0	DRM Master Dual Mode RX Enable 0: RX use single-bit mode 1: RX use dual mode

			Note: Can't be written when XCH=1.
27:24	R/W	0x0	<p>DBC Master Dummy Burst Counter</p> <p>In master mode, this field specifies the burst number that should be sent before receive in dual SPI mode. The data is don't care by the device.</p> <p>0: 0 burst 1: 1 burst ... N: N bursts</p> <p>Note: Can't be written when XCH=1.</p>
23:0	R/W	0x0	<p>STC Master Single Mode Transmit Counter</p> <p>In master mode, this field specifies the burst number that should be sent in single mode before automatically sending dummy burst. This is the first transmit counter in all bursts.</p> <p>0: 0 burst 1: 1 burst ... N: N bursts</p> <p>Note: Can't be written when XCH=1.</p>

**8.2.5.12. SPI TX Data Register(Default Value: 0x00000000)**

Offset: 0x200			Register Name: <b>SPI_TXD</b>
Bit	R/W	Default/Hex	Description
31:0	W/R	0x0	<p>TDATA Transmit Data</p> <p>This register can be accessed in byte, half-word or word unit by AHB. In byte accessing method, if there are rooms in RXFIFO, one burst data is written to RXFIFO and the depth is increased by 1. In half-word accessing method, two SPI burst data are written and the TXFIFO depth is increase by 2. In word accessing method, four SPI burst data are written and the TXFIFO depth is increased by 4.</p> <p>Note: This address is writing-only if TF_TEST is '0', and if TF_TEST is set to '1', this address is readable and writable to test the TX FIFO through the AHB bus.</p>

**8.2.5.13. SPI RX Data Register(Default Value: 0x00000000)**

Offset: 0x300			Register Name: <b>SPI_RXD</b>
Bit	R/W	Default/Hex	Description
31:0	R	0	<p>RDATA Receive Data</p>

			<p>This register can be accessed in byte, half-word or word unit by AHB. In byte accessing method, if there are data in RXFIFO, the top word is returned and the RXFIFO depth is decreased by 1. In half-word accessing method, two SPI bursts are returned and the RXFIFO depth is decrease by 2. In word accessing method, the four SPI bursts are returned and the RXFIFO depth is decreased by 4.</p> <p>Note: This address is read-only if RF_TEST is '0', and if RF_TEST is set to '1', this address is readable and writable to test the RX FIFO through the AHB bus.</p>
--	--	--	--

Confidential

## 8.3. UART

### 8.3.1. Overview

The UART is used for serial communication with a peripheral, modem (data carrier equipment, DCE) or data set. Data is written from a master (CPU) over the APB bus to the UART and it is converted to serial form and transmitted to the destination device. Serial data is also received by the UART and stored for the master (CPU) to read back.

The UART contains registers to control the character length, baud rate, parity generation/checking, and interrupt generation. Although there is only one interrupt output signal from the UART, there are several prioritized interrupt types that can be responsible for its assertion. Each of the interrupt types can be separately enabled/disabled with the control registers.

The UART has 16450 and 16550 modes of operation, which are compatible with a range of standard software drivers. In 16550 mode, transmit and receive operations are both buffered by FIFOs. In 16450 mode, these FIFOs are disabled.

The UART supports data lengths from five to eight bits, an optional parity bit and 1, 1 ½ or 2 stop bits, and is fully programmable by an AMBA APB CPU interface. A 16-bit programmable baud rate generator and an 8-bit scratch register are included, together with separate transmit and receive FIFOs. Eight modem control lines and a diagnostic loop-back mode are provided.

Interrupts can be generated for a range of TX Buffer/FIFO, RX Buffer/FIFO, Modem Status and Line Status conditions.

The UART includes the following features:

- Compatible with industry-standard 16550 UARTs
- 64-Bytes Transmit and receive data FIFOs
- DMA controller interface
- Software/ Hardware Flow Control
- Programmable Transmit Holding Register Empty interrupt
- Interrupt support for FIFOs, Status Change
- Support IrDA 1.0 SIR

### 8.3.2. UART Timing Diagram

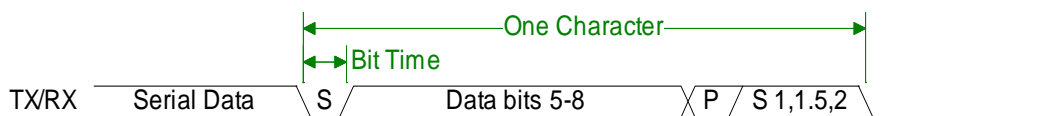

Figure 8-4. UART Serial Data Format

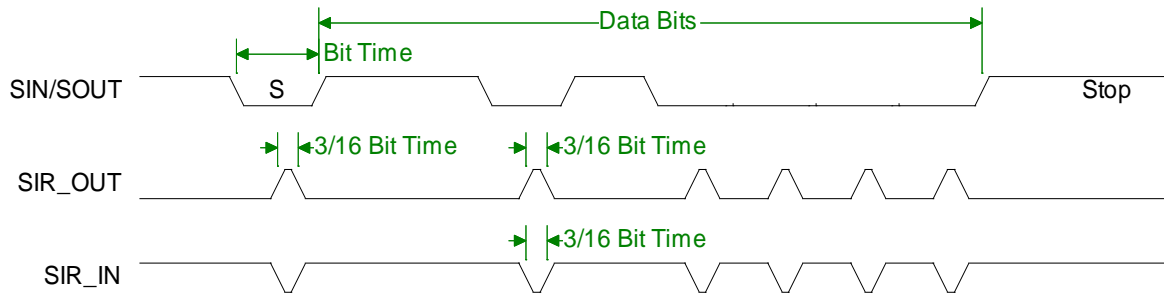

Figure 8-5. Serial IrDA Data Format

### 8.3.3. UART Pin List

Port Name	Width	Direction	Description
UART0_TX	1	OUT	UART Serial Bit output
UART0_RX	1	IN	UART Serial Bit input
UART1_TX	1	OUT	UART Serial Bit output
UART1_RX	1	IN	UART Serial Bit input
UART1_RTS	1	OUT	UART Request To Send This active low output signal informs Modem that the UART is ready to send data
UART1_CTS	1	IN	UART Clear To End This active low signal is an input showing when Modem is ready to accept data
UART2_TX	1	OUT	UART Serial Bit output
UART2_RX	1	IN	UART Serial Bit input
UART2_RTS	1	OUT	UART Request To Send This active low output signal informs Modem that the UART is ready to send data
UART2_CTS	1	IN	UART Clear To End This active low signal is an input showing when Modem is ready to accept data
UART3_TX	1	OUT	UART Serial Bit output
UART3_RX	1	IN	UART Serial Bit input
UART3_RTS	1	OUT	UART Request To Send This active low output signal informs Modem that the UART is ready to send data
UART3_CTS	1	IN	UART Clear To End This active low signal is an input showing when Modem is ready to accept data
S_UART_TX	1	OUT	UART Serial Bit output
S_UART_RX	1	IN	UART Serial Bit input

### 8.3.4. UART Controller Register List

There are 5 UART controllers. All UART controllers can be configured as Serial IrDA.

Module Name	Base Address
UART0	0x01C28000
UART1	0x01C28400
UART2	0x01C28800
UART3	0x01C28C00
R-UART	0x01F02800

Register Name	Offset	Description
UART_RBR	0x00	UART Receive Buffer Register
UART_THR	0x00	UART Transmit Holding Register
UART_DLL	0x00	UART Divisor Latch Low Register
UART_DLH	0x04	UART Divisor Latch High Register
UART_IER	0x04	UART Interrupt Enable Register
UART_IIR	0x08	UART Interrupt Identity Register
UART_FCR	0x08	UART FIFO Control Register
UART_LCR	0x0C	UART Line Control Register
UART_MCR	0x10	UART Modem Control Register
UART_LSR	0x14	UART Line Status Register
UART_MSR	0x18	UART Modem Status Register
UART_SCH	0x1C	UART Scratch Register
UART_USR	0x7C	UART Status Register
UART_TFL	0x80	UART Transmit FIFO Level
UART_RFL	0x84	UART_RFL
UART_HALT	0xA4	UART Halt TX Register

### 8.3.5. UART Register Description

#### 8.3.5.1. UART Receiver Buffer Register(Default Value: 0x00000000)

Offset: 0x0000			Register Name: <b>UART_RBR</b>
Bit	R/W	Default/Hex	Description
31:8	/	/	/
7:0	R	0	RBR Receiver Buffer Register Data byte received on the serial input port . The data in this register is valid only if the Data Ready (DR) bit in the Line Status Register (LCR) is set.

			<p>If in FIFO mode and FIFOs are enabled (FCR[0] set to one), this register accesses the head of the receive FIFO. If the receive FIFO is full and this register is not read before the next data character arrives, then the data already in the FIFO is preserved, but any incoming data are lost and an overrun error occurs.</p>
--	--	--	--

### 8.3.5.2. UART Transmit Holding Register(Default Value: 0x00000000)

Offset: 0x0000			Register Name: <b>UART_THR</b>
Bit	R/W	Default/Hex	Description
31:8	/	/	/
7:0	W	0	<p>THR Transmit Holding Register Data to be transmitted on the serial output port . Data should only be written to the THR when the THR Empty (THRE) bit (LSR[5]) is set. If in FIFO mode and FIFOs are enabled (FCR[0] = 1) and THRE is set, 16 number of characters of data may be written to the THR before the FIFO is full. Any attempt to write data when the FIFO is full results in the write data being lost.</p>

### 8.3.5.3. UART Divisor Latch Low Register(Default Value: 0x00000000)

Offset: 0x0000			Register Name: <b>UART_DLL</b>
Bit	R/W	Default/Hex	Description
31:8	/	/	/
7:0	R/W	0	<p>DLL Divisor Latch Low Lower 8 bits of a 16-bit, read/write, Divisor Latch register that contains the baud rate divisor for the UART. This register may only be accessed when the DLAB bit (LCR[7]) is set and the UART is not busy (USR[0] is zero). The output baud rate is equal to the serial clock (sclk) frequency divided by sixteen times the value of the baud rate divisor, as follows: baud rate = (serial clock freq) / (16 * divisor). Note that with the Divisor Latch Registers (DLL and DLH) set to zero, the baud clock is disabled and no serial communications occur. Also, once the DLL is set, at least 8 clock cycles of the slowest UART clock should be allowed to pass before transmitting or receiving data.</p>

**8.3.5.4. UART Divisor Latch High Register(Default Value: 0x00000000)**

Offset: 0x0004			Register Name: <b>UART_DLH</b>
Bit	R/W	Default/Hex	Description
31:8	/	/	/
7:0	R/W	0	<p>DLH Divisor Latch High</p> <p>Upper 8 bits of a 16-bit, read/write, Divisor Latch register that contains the baud rate divisor for the UART. This register may only be accessed when the DLAB bit (LCR[7]) is set and the UART is not busy (USR[0] is zero).</p> <p>The output baud rate is equal to the serial clock (sclk) frequency divided by sixteen times the value of the baud rate divisor, as follows: baud rate = (serial clock freq) / (16 * divisor).</p> <p>Note that with the Divisor Latch Registers (DLL and DLH) set to zero, the baud clock is disabled and no serial communications occur. Also, once the DLH is set, at least 8 clock cycles of the slowest UART clock should be allowed to pass before transmitting or receiving data.</p>

**8.3.5.5. UART Interrupt Enable Register(Default Value: 0x0000\_0000)**

Offset: 0x0004			Register Name: <b>UART_IER</b>
Bit	R/W	Default/Hex	Description
31:8	/	/	/
7	R/W		<p>PTIME Programmable THRE Interrupt Mode Enable</p> <p>This is used to enable/disable the generation of THRE Interrupt.</p> <p>0: Disable 1: Enable</p>
6:4	/	/	/
3	R/W	0	<p>EDSSI Enable Modem Status Interrupt</p> <p>This is used to enable/disable the generation of Modem Status Interrupt. This is the fourth highest priority interrupt.</p> <p>0: Disable 1: Enable</p>
2	R/W	0	<p>ELSI Enable Receiver Line Status Interrupt</p> <p>This is used to enable/disable the generation of Receiver Line Status Interrupt. This is the highest priority interrupt.</p> <p>0: Disable 1: Enable</p>
1	R/W	0	ETBEI



			<p>Enable Transmit Holding Register Empty Interrupt</p> <p>This is used to enable/disable the generation of Transmitter Holding Register Empty Interrupt. This is the third highest priority interrupt.</p> <p>0: Disable 1: Enable</p>
0	R/W	0	<p>ERBFI</p> <p>Enable Received Data Available Interrupt</p> <p>This is used to enable/disable the generation of Received Data Available Interrupt and the Character Timeout Interrupt (if in FIFO mode and FIFOs enabled). These are the second highest priority interrupts.</p> <p>0: Disable 1: Enable</p>

### 8.3.5.6. UART Interrupt Identity Register(Default Value: 0x00000000)

Offset: 0x0008			Register Name: <b>UART_IIR</b>
Bit	R/W	Default/Hex	Description
31:8	/	/	/
7:6	R	0	<p>FEFLAG</p> <p>FIFOs Enable Flag</p> <p>This is used to indicate whether the FIFOs are enabled or disabled.</p> <p>00: Disable 11: Enable</p>
5:4	/	/	/
3:0	R	0x1	<p>IID</p> <p>Interrupt ID</p> <p>This indicates the highest priority pending interrupt which can be one of the following types:</p> <p>0000: modem status 0001: no interrupt pending 0010: THR empty 0100: received data available 0110: receiver line status 0111: busy detect 1100: character timeout</p> <p>Bit 3 indicates an interrupt can only occur when the FIFOs are enabled and used to distinguish a Character Timeout condition interrupt.</p>

Interrupt ID	Priority Level	Interrupt Type	Interrupt Source	Interrupt Reset
0001	-	None	None	-
0110	Highest	Receiver line status	Overrun/parity/ framing errors or break interrupt	Reading the line status register

0100	Second	Received data available	Receiver data available (non-FIFO mode or FIFOs disabled) or RCVR FIFO trigger level reached (FIFO mode and FIFOs enabled)	Reading the receiver buffer register (non-FIFO mode or FIFOs disabled) or the FIFO drops below the trigger level (FIFO mode and FIFOs enabled)
1100	Second	Character timeout indication	No characters in or out of the RCVR FIFO during the last 4 character times and there is at least 1 character in it during This time	Reading the receiver buffer register
0010	Third	Transmit holding register empty	Transmitter holding register empty (Program THRE Mode disabled) or XMIT FIFO at or below threshold (Program THRE Mode enabled)	Reading the IIR register (if source of interrupt); or, writing into THR (FIFOs or THRE Mode not selected or disabled) or XMIT FIFO above threshold (FIFOs and THRE Mode selected and enabled).
0000	Fourth	Modem status	Clear to send or data set ready or ring indicator or data carrier detect. Note that if auto flow control mode is enabled, a change in CTS (that is, DCTS set) does not cause an interrupt.	Reading the Modem status Register
0111	Fifth	Busy detect indication	UART_16550_COMPATIBLE = NO and master has tried to write to the Line Control Register while the UART is busy (USR[0] is set to one).	Reading the UART status register

### 8.3.5.7. UART FIFO Control Register(Default Value: 0x00000000)

Offset: 0x0008			Register Name: <b>UART_FCR</b>
Bit	R/W	Default/Hex	Description
31:8	/	/	/
7:6	W	0	RT RCVR Trigger This is used to select the trigger level in the receiver FIFO at which the Received Data Available Interrupt is generated. In auto flow control mode it is used to determine when the rts_n signal is de-asserted. It also determines when the dma_rx_req_n signal is asserted in certain modes of operation. 00: 1 character in the FIFO 01: FIFO ¼ full 10: FIFO ½ full 11: FIFO-2 less than full
5:4	W	0	TFT

			<p>TX Empty Trigger</p> <p>Writes have no effect when THRE_MODE_USER = Disabled. This is used to select the empty threshold level at which the THRE Interrupts are generated when the mode is active. It also determines when the dma_tx_req_n signal is asserted when in certain modes of operation.</p> <p>00: FIFO empty 01: 2 characters in the FIFO 10: FIFO ¼ full 11: FIFO ½ full</p>
3	W	0	<p>DMAM</p> <p>DMA Mode</p> <p>0: Mode 0 1: Mode 1</p>
2	W	0	<p>XFIFOR</p> <p>XMIT FIFO Reset</p> <p>This resets the control portion of the transmit FIFO and treats the FIFO as empty. This also de-asserts the DMA TX request. It is 'self-clearing'. It is not necessary to clear this bit.</p>
1	W	0	<p>RFIFOR</p> <p>RCVR FIFO Reset</p> <p>This resets the control portion of the receive FIFO and treats the FIFO as empty. This also de-asserts the DMA RX request. It is 'self-clearing'. It is not necessary to clear this bit.</p>
0	W	0	<p>FIFOE</p> <p>Enable FIFOs</p> <p>This enables/disables the transmit (XMIT) and receive (RCVR) FIFOs. Whenever the value of this bit is changed both the XMIT and RCVR controller portion of FIFOs is reset.</p>

### 8.3.5.8. UART Line Control Register(Default Value: 0x00000000)

Offset: 0x000C			Register Name: <b>UART_LCR</b>
Bit	R/W	Default/Hex	Description
31:8	/	/	/
7	R/W	0	<p>DLAB</p> <p>Divisor Latch Access Bit</p> <p>It is writeable only when UART is not busy (USR[0] is zero) and always readable. This bit is used to enable reading and writing of the Divisor Latch register (DLL and DLH) to set the baud rate of the UART. This bit must be cleared after initial baud rate setup in order to access other registers.</p> <p>0: Select RX Buffer Register (RBR) / TX Holding Register(THR) and Interrupt Enable Register (IER) 1: Select Divisor Latch LS Register (DLL) and Divisor Latch MS Register (DLM)</p>
6	R/W	0	BC

			<p><b>Break Control Bit</b></p> <p>This is used to cause a break condition to be transmitted to the receiving device. If set to one the serial output is forced to the spacing (logic 0) state. When not in Loopback Mode, as determined by MCR[4], the sout line is forced low until the Break bit is cleared. If SIR_MODE = Enabled and active (MCR[6] set to one) the sir_out_n line is continuously pulsed. When in Loopback Mode, the break condition is internally looped back to the receiver and the sir_out_n line is forced low.</p>
5:4	R/W	0	<p><b>EPS</b></p> <p><b>Even Parity Select</b></p> <p>It is writeable only when UART is not busy (USR[0] is zero) and always writable readable. This is used to select between even and odd parity, when parity is enabled (PEN set to one). Setting the LCR[5] is to reverse the LCR[4].</p> <p>00: Odd Parity 01: Even Parity 1X: Reverse LCR[4]</p>
3	R/W	0	<p><b>PEN</b></p> <p><b>Parity Enable</b></p> <p>It is writeable only when UART is not busy (USR[0] is zero) and always readable. This bit is used to enable and disable parity generation and detection in transmitted and received serial character respectively.</p> <p>0: parity disabled 1: parity enabled</p>
2	R/W	0	<p><b>STOP</b></p> <p><b>Number of stop bits</b></p> <p>It is writeable only when UART is not busy (USR[0] is zero) and always readable. This is used to select the number of stop bits per character that the peripheral transmits and receives. If set to zero, one stop bit is transmitted in the serial data. If set to one and the data bits are set to 5 (LCR[1:0] set to zero) one and a half stop bits is transmitted. Otherwise, two stop bits are transmitted. Note that regardless of the number of stop bits selected, the receiver checks only the first stop bit.</p> <p>0: 1 stop bit 1: 1.5 stop bits when DLS (LCR[1:0]) is zero, else 2 stop bit</p>
1:0	R/W	0	<p><b>DLS</b></p> <p><b>Data Length Select</b></p> <p>It is writeable only when UART is not busy (USR[0] is zero) and always readable. This is used to select the number of data bits per character that the peripheral transmits and receives. The number of bit that may be selected areas follows:</p> <p>00: 5 bits 01: 6 bits 10: 7 bits 11: 8 bits</p>

**8.3.5.9. UART Modem Control Register(Default Value: 0x00000000)**

Offset: 0x0010			Register Name: <b>UART_MCR</b>
Bit	R/W	Default/Hex	Description
31:6	/	/	/
5	R/W	0	<p><b>AFCE</b> Auto Flow Control Enable</p> <p>When FIFOs are enabled and the Auto Flow Control Enable (AFCE) bit is set, Auto Flow Control features are enabled.</p> <p>0: Auto Flow Control Mode disabled 1: Auto Flow Control Mode enabled</p>
4	R/W	0	<p><b>LOOP</b> Loop Back Mode</p> <p>0: Normal Mode 1: Loop Back Mode</p> <p>This is used to put the UART into a diagnostic mode for test purposes. If operating in UART mode (SIR_MODE != Enabled or not active, MCR[6] set to zero), data on the sout line is held high, while serial data output is looped back to the sin line, internally. In this mode all the interrupts are fully functional. Also, in loopback mode, the modem control inputs (dsr_n, cts_n, ri_n, dcd_n) are disconnected and the modem control outputs (dtr_n, rts_n, out1_n, out2_n) are looped back to the inputs, internally. If operating in infrared mode (SIR_MODE == Enabled AND active, MCR[6] set to one), data on the sir_out_n line is held low, while serial data output is inverted and looped back to the sir_in line.</p>
3:2	/	/	/
1	R/W	0	<p><b>RTS</b> Request to Send</p> <p>This is used to directly control the Request to Send (rts_n) output. The Request To Send (rts_n) output is used to inform the modem or data set that the UART is ready to exchange data. When Auto RTS Flow Control is not enabled (MCR[5] set to zero), the rts_n signal is set low by programming MCR[1] (RTS) to a high. In Auto Flow Control, AFCE_MODE == Enabled and active (MCR[5] set to one) and FIFOs enable (FCR[0] set to one), the rts_n output is controlled in the same way, but is also gated with the receiver FIFO threshold trigger (rts_n is inactive high when above the threshold). The rts_n signal is de-asserted when MCR[1] is set low.</p> <p>0: rts_n de-asserted (logic 1) 1: rts_n asserted (logic 0)</p> <p>Note that in Loopback mode (MCR[4] set to one), the rts_n output is held inactive high while the value of this location is internally looped back to an input.</p>
0	R/W	0	<p><b>DTR</b> Data Terminal Ready</p> <p>This is used to directly control the Data Terminal Ready (dtr_n) output. The</p>

			<p>value written to this location is inverted and driven out on dtr_n.</p> <p>0: dtr_n de-asserted (logic 1)</p> <p>1: dtr_n asserted (logic 0)</p> <p>The Data Terminal Ready output is used to inform the modem or data set that the UART is ready to establish communications.</p> <p>Note that in Loopback mode (MCR[4] set to one), the dtr_n output is held inactive high while the value of this location is internally looped back to an input.</p>
--	--	--	---

### 8.3.5.10. UART Line Status Register(Default Value: 0x0000060)

Offset: 0x0014			Register Name: <b>UART_LSR</b>
Bit	R/W	Default/Hex	Description
31:8	/	/	/
7	R	0	<p><b>FIFOERR</b> RX Data Error in FIFO</p> <p>When FIFOs are disabled, this bit is always 0. When FIFOs are enabled, this bit is set to 1 when there is at least one PE, FE, or BI in the RX FIFO. It is cleared by a read from the LSR register provided there are no subsequent errors in the FIFO.</p>
6	R	1	<p><b>TEMT</b> Transmitter Empty</p> <p>If the FIFOs are disabled, this bit is set to "1" whenever the TX Holding Register and the TX Shift Register are empty. If the FIFOs are enabled, this bit is set whenever the TX FIFO and the TX Shift Register are empty. In both cases, this bit is cleared when a byte is written to the TX data channel.</p>
5	R	1	<p><b>THRE</b> TX Holding Register Empty</p> <p>If the FIFOs are disabled, this bit is set to "1" whenever the TX Holding Register is empty and ready to accept new data and it is cleared when the CPU writes to the TX Holding Register.</p> <p>If the FIFOs are enabled, this bit is set to "1" whenever the TX FIFO is empty and it is cleared when at least one byte is written to the TX FIFO.</p>
4	R	0	<p><b>BI</b> Break Interrupt</p> <p>This is used to indicate the detection of a break sequence on the serial input data.</p> <p>It is set whenever the serial input, sin, is held in a logic '0' state for longer than the sum of start time + data bits + parity + stop bits.</p> <p>In the FIFO mode, the character associated with the break condition is carried through the FIFO and is revealed when the character is at the top of the FIFO. Reading the LSR clears the BI bit. In the non-FIFO mode, the BI indication occurs immediately and persists until the LSR is read.</p>

3	R	0	<p>FE Framing Error</p> <p>This is used to indicate the occurrence of a framing error in the receiver. A framing error occurs when the receiver does not detect a valid STOP bit in the received data.</p> <p>In the FIFO mode, since the framing error is associated with a character received, it is revealed when the character with the framing error is at the top of the FIFO. When a framing error occurs, the UART tries to resynchronize. It does this by assuming that the error was due to the start bit of the next character and then continues receiving the other bit i.e. data, and/or parity and stop. It should be noted that the Framing Error (FE) bit (LSR[3]) is set if a break interrupt has occurred, as indicated by Break Interrupt (BI) bit (LSR[4]).</p> <p>0: no framing error 1: framing error</p> <p>Reading the LSR clears the FE bit.</p>
2	R	0	<p>PE Parity Error</p> <p>This is used to indicate the occurrence of a parity error in the receiver if the Parity Enable (PEN) bit (LCR[3]) is set. In the FIFO mode, since the parity error is associated with a character received, it is revealed when the character with the parity error arrives at the top of the FIFO. It should be noted that the Parity Error (PE) bit (LSR[2]) is set if a break interrupt has occurred, as indicated by Break Interrupt (BI) bit (LSR[4]).</p> <p>0: no parity error 1: parity error</p> <p>Reading the LSR clears the PE bit.</p>
1	R	0	<p>OE Overrun Error</p> <p>This occurs if a new data character was received before the previous data was read. In the non-FIFO mode, the OE bit is set when a new character arrives in the receiver before the previous character was read from the RBR. When this happens, the data in the RBR is overwritten. In the FIFO mode, an overrun error occurs when the FIFO is full and a new character arrives at the receiver. The data in the FIFO is retained and the data in the receive shift register is lost.</p> <p>0: no overrun error 1: overrun error</p> <p>Reading the LSR clears the OE bit.</p>
0	R	0	<p>DR Data Ready</p> <p>This is used to indicate that the receiver contains at least one character in the RBR or the receiver FIFO.</p> <p>0: no data ready 1: data ready</p>

			This bit is cleared when the RBR is read in non-FIFO mode, or when the receiver FIFO is empty, in FIFO mode.
--	--	--	--

**8.3.5.11. UART Modem Status Register(Default Value: 0x00000000)**

Offset: 0x0018			Register Name: <b>UART_MSR</b>
Bit	R/W	Default/Hex	Description
31:8	/	/	/
7	R	0	<p>DCD Line State of Data Carrier Detect This is used to indicate the current state of the modem control line dcd_n. This bit is the complement of dcd_n. When the Data Carrier Detect input (dcd_n) is asserted it is an indication that the carrier has been detected by the modem or data set. 0: dcd_n input is de-asserted (logic 1) 1: dcd_n input is asserted (logic 0)</p>
6	R	0	<p>RI Line State of Ring Indicator This is used to indicate the current state of the modem control line ri_n. This bit is the complement of ri_n. When the Ring Indicator input (ri_n) is asserted it is an indication that a telephone ringing signal has been received by the modem or data set. 0: ri_n input is de-asserted (logic 1) 1: ri_n input is asserted (logic 0)</p>
5	R	0	<p>DSR Line State of Data Set Ready This is used to indicate the current state of the modem control line dsr_n. This bit is the complement of dsr_n. When the Data Set Ready input (dsr_n) is asserted it is an indication that the modem or data set is ready to establish communications with UART. 0: dsr_n input is de-asserted (logic 1) 1: dsr_n input is asserted (logic 0) In Loopback Mode (MCR[4] set to one), DSR is the same as MCR[0] (DTR).</p>
4	R	0	<p>CTS Line State of Clear To Send This is used to indicate the current state of the modem control line cts_n. This bit is the complement of cts_n. When the Clear to Send input (cts_n) is asserted it is an indication that the modem or data set is ready to exchange data with UART. 0: cts_n input is de-asserted (logic 1) 1: cts_n input is asserted (logic 0) In Loopback Mode (MCR[4] = 1), CTS is the same as MCR[1] (RTS).</p>
3	R	0	<p>DDCD Delta Data Carrier Detect</p>



			<p>This is used to indicate that the modem control line dcd_n has changed since the last time the MSR was read.</p> <p>0: no change on dcd_n since last read of MSR 1: change on dcd_n since last read of MSR</p> <p>Reading the MSR clears the DDCD bit.</p> <p>Note: If the DDCD bit is not set and the dcd_n signal is asserted (low) and a reset occurs (software or otherwise), then the DDCD bit is set when the reset is removed if the dcd_n signal remains asserted.</p>
2	R	0	<p>TERI Trailing Edge Ring Indicator</p> <p>This is used to indicate that a change on the input ri_n (from an active-low to an inactive-high state) has occurred since the last time the MSR was read.</p> <p>0: no change on ri_n since last read of MSR 1: change on ri_n since last read of MSR</p> <p>Reading the MSR clears the TERI bit.</p>
1	R	0	<p>DDSR Delta Data Set Ready</p> <p>This is used to indicate that the modem control line dsr_n has changed since the last time the MSR was read.</p> <p>0: no change on dsr_n since last read of MSR 1: change on dsr_n since last read of MSR</p> <p>Reading the MSR clears the DDSR bit. In Loopback Mode (MCR[4] = 1), DDSR reflects changes on MCR[0] (DTR).</p> <p>Note: If the DDSR bit is not set and the dsr_n signal is asserted (low) and a reset occurs (software or otherwise), then the DDSR bit is set when the reset is removed if the dsr_n signal remains asserted.</p>
0	R	0	<p>DCTS Delta Clear to Send</p> <p>This is used to indicate that the modem control line cts_n has changed since the last time the MSR was read.</p> <p>0: no change on ctsdsr_n since last read of MSR 1: change on ctsdsr_n since last read of MSR</p> <p>Reading the MSR clears the DCTS bit. In Loopback Mode (MCR[4] = 1), DCTS reflects changes on MCR[1] (RTS).</p> <p>Note: If the DCTS bit is not set and the cts_n signal is asserted (low) and a reset occurs (software or otherwise), then the DCTS bit is set when the reset is removed if the cts_n signal remains asserted.</p>

### 8.3.5.12. UART Scratch Register(Default Value: 0x00000000)

Offset: 0x001C			Register Name: <b>UART_SCH</b>
Bit	R/W	Default/Hex	Description
31:8	/	/	/
7:0	R/W	0	SCRATCH_REG

			Scratch Register This register is for programmers to use as a temporary storage space. It has no defined purpose in the UART.
--	--	--	--

**8.3.5.13. UART Status Register(Default Value: 0x00000006)**

Offset: 0x007C			Register Name: <b>UART_USR</b>
Bit	R/W	Default/Hex	Description
31:5	/	/	/
4	R	0	<b>RFF</b> Receive FIFO Full This is used to indicate that the receive FIFO is completely full. 0: Receive FIFO not full 1: Receive FIFO Full This bit is cleared when the RX FIFO is no longer full.
3	R	0	<b>RFNE</b> Receive FIFO Not Empty This is used to indicate that the receive FIFO contains one or more entries. 0: Receive FIFO is empty 1: Receive FIFO is not empty This bit is cleared when the RX FIFO is empty.
2	R	1	<b>TFE</b> Transmit FIFO Empty This is used to indicate that the transmit FIFO is completely empty. 0: Transmit FIFO is not empty 1: Transmit FIFO is empty This bit is cleared when the TX FIFO is no longer empty.
1	R	1	<b>TFNF</b> Transmit FIFO Not Full This is used to indicate that the transmit FIFO is not full. 0: Transmit FIFO is full 1: Transmit FIFO is not full This bit is cleared when the TX FIFO is full.
0	R	0	<b>BUSY</b> UART Busy Bit 0: Idle or inactive 1: Busy

**8.3.5.14. UART Transmit FIFO Level Register(Default Value: 0x00000000)**

Offset: 0x0080			Register Name: <b>UART_TFL</b>
Bit	R/W	Default/Hex	Description

31:7	/	/	/
6:0	R	0	TFL Transmit FIFO Level This indicates the number of data entries in the transmit FIFO.

**8.3.5.15. UART Receive FIFO Level Register(Default Value: 0x00000000)**

Offset: 0x0084			Register Name: <b>UART_RFL</b>
Bit	R/W	Default/Hex	Description
31:7	/	/	/
6:0	R	0	RFL Receive FIFO Level This indicates the number of data entries in the receive FIFO.

**8.3.5.16. UART Halt TX Register(Default Value: 0x00000000)**

Offset: 0x00A4			Register Name: <b>UART_HALT</b>
Bit	R/W	Default/Hex	Description
31:4	/	/	/
5	R/W	0	SIR_RX_INVERT SIR Receiver Pulse Polarity Invert 0: Not invert receiver signal 1: Invert receiver signal
4	R/W	0	SIR_TX_INVERT SIR Transmit Pulse Polarity Invert 0: Not invert transmit pulse 1: Invert transmit pulse
3	/	/	/
2	R/W	0	CHANGE_UPDATE After the user using HALT[1] to change the baudrate or LCR configuration, write 1 to update the configuration and waiting this bit self clear to 0 to finish update process. Write 0 to this bit has no effect. 1: Update trigger, Self clear to 0 when finish update.
1	R/W	0	CHCFG_AT_BUSY This is an enable bit for the user to change LCR register configuration (except for the DLAB bit) and baudrate register (DLH and DLL) when the UART is busy (USB[0] is 1). 1: Enable change when busy
0	R/W	0	HALT_TX Halt TX This register is use to halt transmissions for testing, so that the transmit FIFO can be filled by the master when FIFOs are implemented and enabled.

			0 : Halt TX disabled 1 : Halt TX enabled Note: If FIFOs are not enabled, the setting of the halt TX register has no effect on operation.
--	--	--	--

Confidential

## 8.4. CIR Receiver

### 8.4.1. Overview

The CIR includes the following features:

- Full physical layer implementation
- Support CIR for remote control
- 64x8 bits FIFO for data buffer
- Programmable FIFO thresholds

For saving CPU resource, CIR receiver is implemented in hardware. The CIR receiver samples the input signal on the programmable frequency and records these samples into RX FIFO when one CIR signal is found on the air. The CIR receiver uses Run-Length Code (RLC) to encode pulse width. The encoded data is buffered in a 64 levels and 8-bit width RX FIFO; the MSB bit is used to record the polarity of the receiving CIR signal. The high level is represented as '1' and the low level is represented as '0'. The rest 7 bits are used for the length of RLC. The maximum length is 128. If the duration of one level (high or low level) is more than 128, another byte is used.

In the air, there is always some noise. One threshold can be set to filter the noise to reduce system loading and improve the system stability.

### 8.4.2. CIR Receiver Register List

Module Name	Base Address
CIR	0x01F02000

Register Name	Offset	Description
CIR_CTL	0x00	CIR Control Register
CIR_RXCTL	0x10	CIR Receiver Configure Register
CIR_RXFIFO	0x20	CIR Receiver FIFO Register
CIR_RXINT	0x2C	CIR Receiver Interrupt Control Register
CIR_RXSTA	0x30	CIR Receiver Status Register
CIR_CONFIG	0x34	CIR Configure Register

### 8.4.3. CIR Receiver Register Description

#### 8.4.3.1. CIR Receiver Control Register(Default Value: 0x00000000)

Offset: 0x0000			Register Name: <b>CIR_CTL</b>
Bit	R/W	Default/Hex	Description
31:9	/	/	/
8	R/W	0	CGPO General Program Output (GPO) Control in CIR mode for TX Pin 0: Low level 1: High level
7:6	/	/	/
5:4	R/W	0	CIR ENABLE 00~10: Reserved 11: CIR mode enable
3:2	/	/	/.
1	R/W	0	RXEN Receiver Block Enable 0: Disable 1: Enable
0	R/W	0	GEN Global Enable A disable on this bit overrides any other block or channel enables and flushes all FIFOs. 0: Disable 1: Enable

#### 8.4.3.2. CIR Receiver Configure Register(Default Value: 0x00000004)

Offset: 0x0010			Register Name: <b>CIR_RXCTL</b>
Bit	R/W	Default/Hex	Description
31:3	/	/	/
2	R/W	1	RPPI Receiver Pulse Polarity Invert 0: Not invert receiver signal 1: Invert receiver signal
1:0	/	/	/

#### 8.4.3.3. CIR Receiver FIFO Register(Default Value: 0x00000000)

Offset: 0x0020			Register Name: <b>CIR_RXFIFO</b>
----------------	--	--	----------------------------------

Bit	R/W	Default/Hex	Description
31:8	/	/	/
7:0	R	0	Receiver Byte FIFO

**8.4.3.4. CIR Receiver Interrupt Control Register(Default Value: 0x00000000)**

Offset: 0x002C			Register Name: <b>CIR_RXINT</b>
Bit	R/W	Default/Hex	Description
31:14	/	/	/
13:8	R/W	0	RAL RX FIFO Available Received Byte Level for interrupt and DMA request TRIGGER_LEVEL = RAL + 1
5	R/W	0	DRQ_EN RX FIFO DMA Enable 0: Disable 1: Enable When set to '1', the Receiver FIFO DRQ is asserted if reaching RAL. The DRQ is de-asserted when condition fails.
4	R/W	0	RAI_EN RX FIFO Available Interrupt Enable 0: Disable 1: Enable When set to '1', the Receiver FIFO IRQ is asserted if reaching RAL. The IRQ is de-asserted when condition fails.
3:2	/	/	/
1	R/W	0	RPEI_EN Receiver Packet End Interrupt Enable 0: Disable 1: Enable
0	R/W	0	ROI_EN Receiver FIFO Overrun Interrupt Enable 0: Disable 1: Enable

**8.4.3.5. CIR Receiver Status Register(Default Value: 0x00000000)**

Offset: 0x0030			Register Name: <b>CIR_RXSTA</b>
Bit	R/W	Default/Hex	Description
31:15	/	/	/
14:8	R	0	RAC RX FIFO Available Counter 0: No available data in RX FIFO

			1: 1 byte available data in RX FIFO 2: 2 byte available data in RX FIFO ... 64: 64 byte available data in RX FIFO
7	R	0x0	STAT Status of CIR 0x0 – Idle 0x1 – busy
6:5	/	/	/
4	R/W	0	RA RX FIFO Available 0: RX FIFO not available according its level 1: RX FIFO available according its level This bit is cleared by writing a '1'.
3:2	/	/	/
1	R/W	0	RPE Receiver Packet End Flag 0: STO was not detected. In CIR mode, one CIR symbol is receiving or not detected. 1: STO field or packet abort symbol (7'b0000,000 and 8'b0000,0000 for MIR and FIR) is detected. In CIR mode, one CIR symbol is received. This bit is cleared by writing a '1'.
0	R/W	0	ROI Receiver FIFO Overrun 0: Receiver FIFO not overrun 1: Receiver FIFO overrun This bit is cleared by writing a '1'.

#### 8.4.3.6. CIR Receiver Configure Register(Default Value: 0x00000000)

Offset: 0x0034			Register Name: <b>CIR_RCR</b>
Bit	R/W	Default/Hex	Description
31	/	/	/
30:25	/	/	/
24	R/W	0x0	SCS2 Bit2 of Sample Clock Select for CIR This bit is defined by SCS bits below.
23	R/W	0x0	ATHC Active Threshold Control for CIR 0x0 –ATHR in Unit of (Sample Clock) 0x1 –ATHR in Unit of (128*Sample Clocks)
22:16	R/W	0x0	ATHR Active Threshold for CIR These bits control the duration of CIR from Idle to Active State. The duration



			can be calculated by $((ATHR + 1) * (ATHC? \text{ Sample Clock: } 128 * \text{ Sample Clock}))$ .																																				
15:8	R/W	0x18	<p><b>ITHR</b> Idle Threshold for CIR</p> <p>The Receiver uses it to decide whether the CIR command has been received. If there is no CIR signal on the air, the receiver is staying in IDLE status. One active pulse will bring the receiver from IDLE status to Receiving status. After the CIR is end, the inputting signal will keep the specified level (high or low level) for a long time. The receiver can use this idle signal duration to decide that it has received the CIR command. The corresponding flag is asserted. If the corresponding interrupt is enable, the interrupt line is asserted to CPU. When the duration of signal keeps one status (high or low level) for the specified duration ( <math>(ITHR + 1) * 128 \text{ sample\_clk}</math> ), this means that the previous CIR command has been finished.</p>																																				
7:2	R/W	0xa	<p><b>NTHR</b> Noise Threshold for CIR</p> <p>When the duration of signal pulse (high or low level) is less than NTHR, the pulse is taken as noise and should be discarded by hardware.</p> <p>0: all samples are recorded into RX FIFO            1: If the signal is only one sample duration, it is taken as noise and discarded.            2: If the signal is less than (<math>\leq</math>) two sample duration, it is taken as noise and discarded.            ...            61: if the signal is less than (<math>\leq</math>) sixty-one sample duration, it is taken as noise and discarded.</p>																																				
1:0	R/W	0	<p><b>SCS</b> Sample Clock Select for CIR</p> <table border="1"> <thead> <tr> <th>SCS2</th> <th>SCS[1]</th> <th>SCS[0]</th> <th>Sample Clock</th> </tr> </thead> <tbody> <tr> <td>0</td> <td>0</td> <td>0</td> <td>ir_clk/64</td> </tr> <tr> <td>0</td> <td>0</td> <td>1</td> <td>ir_clk/128</td> </tr> <tr> <td>0</td> <td>1</td> <td>0</td> <td>ir_clk/256</td> </tr> <tr> <td>0</td> <td>1</td> <td>1</td> <td>ir_clk/512</td> </tr> <tr> <td>1</td> <td>0</td> <td>0</td> <td>ir_clk</td> </tr> <tr> <td>1</td> <td>0</td> <td>1</td> <td>Reserved</td> </tr> <tr> <td>1</td> <td>1</td> <td>0</td> <td>Reserved</td> </tr> <tr> <td>1</td> <td>1</td> <td>1</td> <td>Reserved</td> </tr> </tbody> </table>	SCS2	SCS[1]	SCS[0]	Sample Clock	0	0	0	ir_clk/64	0	0	1	ir_clk/128	0	1	0	ir_clk/256	0	1	1	ir_clk/512	1	0	0	ir_clk	1	0	1	Reserved	1	1	0	Reserved	1	1	1	Reserved
SCS2	SCS[1]	SCS[0]	Sample Clock																																				
0	0	0	ir_clk/64																																				
0	0	1	ir_clk/128																																				
0	1	0	ir_clk/256																																				
0	1	1	ir_clk/512																																				
1	0	0	ir_clk																																				
1	0	1	Reserved																																				
1	1	0	Reserved																																				
1	1	1	Reserved																																				

## 8.5. USB

### 8.5.1. USB OTG Controller

#### 8.5.1.1. Overview

The USB OTG is a Dual-Role Device controller, which supports both device and host functions which can also be configured as a Host-only or Device-only controller, fully compliant with the USB 2.0 Specification. It can support high-speed (HS, 480-Mbps), full-speed (FS, 12-Mbps), and low-speed (LS, 1.5-Mbps) transfers in Host mode. It can support high-speed (HS, 480-Mbps), and full-speed (FS, 12-Mbps) in Device mode. Standard USB transceiver can be used through its UTMI+PHY Level3 interface. The UTMI+PHY interface is bidirectional with 8-bit data bus. For saving CPU bandwidth, USB-OTG DMA interface can support external DMA controller to take care of the data transfer between the memory and USB-OTG FIFO. The USB-OTG core also supports USB power saving functions.

The USB2.0 OTG controller has following features:

- Complies with USB 2.0 Specification
- Support Device or Host operation at a time
- Support High-Speed (HS, 480-Mbps), Full-Speed (FS, 12-Mbps), and Low-Speed (LS, 1.5-Mbps) in host mode
- Complies with Enhanced Host Controller Interface (EHCI) Specification, Version 1.0, and the Open Host Controller Interface (OHCI) Specification, Version 1.0a for host mode
- Support High-Speed (HS, 480-Mbps), Full-Speed (FS, 12-Mbps) in device mode
- Supports bi-directional endpoint0 for Control transfer in device mode
- Supports up to 8 User-Configurable Endpoints for Bulk , Isochronous and Interrupt bi-directional transfers (Endpoint1, Endpoint2, Endpoint3, Endpoint4, Endpoint5) in device mode
- Supports up to (4KB+64B) FIFO for EPs (Excluding EP0) in device mode
- Supports the UTMI+ Level 3 interface . The 8-bit bidirectional data buses are used
- Supports point-to-point and point-to-multipoint transfer in both Host and Peripheral mode
- Power Optimization and Power Management capabilities

#### 8.5.1.2. Block Diagram

Figure 8-6 shows the block diagram of USB OTG Controller:

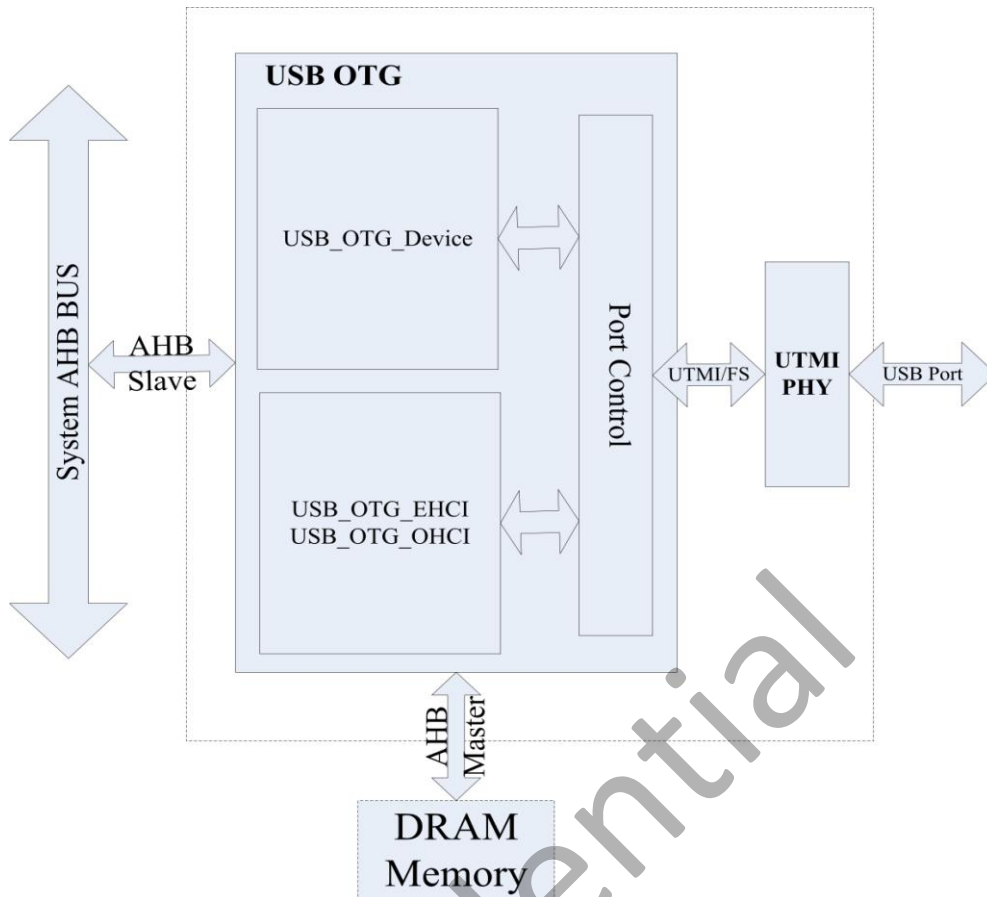

Figure 8-6. USB OTG Controller Block Diagram

## 8.5.2. USB Host Controller

### 8.5.2.1. Overview

USB Host Controller is fully compliant with the USB 2.0 specification, Enhanced Host Controller Interface (EHCI) Specification, Revision 1.0, and the Open Host Controller Interface (OHCI) Specification Release 1.0a. The controller supports high-speed, 480-Mbps transfers (40 times faster than USB 1.1 full-speed mode) using an EHCI Host Controller, as well as full and low speeds through one or more integrated OHCI Host Controllers.

The USB host controller includes the following features:

- Supports industry-standard AMBA High-Performance Bus (AHB) and it is fully compliant with the AMBA Specification, Revision 2.0.
- Supports 32-bit Little Endian AMBA AHB Slave Bus for Register Access.
- Supports 32-bit Little Endian AMBA AHB Master Bus for Memory Access.
- Including an internal DMA Controller for data transfer with memory.
- Complies with Enhanced Host Controller Interface (EHCI) Specification, Version 1.0, and the Open Host Controller Interface (OHCI) Specification, Version 1.0a.
- Supports High-Speed (HS, 480-Mbps), Full-Speed (FS, 12-Mbps), and Low-Speed (LS, 1.5-Mbps) Device.

- Supports the UTMI+ Level 3 interface . The 8-bit bidirectional data buses are used.
- Supports only 1 USB Root Port shared between EHCI and OHCI.

**8.5.2.2. Block Diagram**

Figure 8-7 shows the USB Host Controller system-level block diagram:

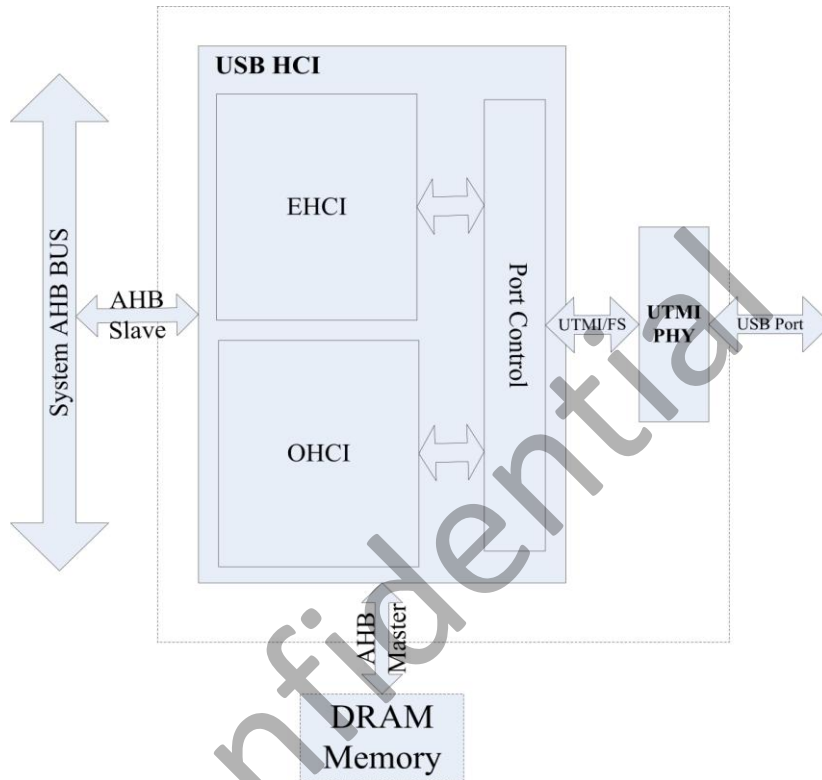

Figure 8-7. USB Host Controller Block Diagram

**8.5.2.3. USB Host Timing Diagram**

Please refer USB2.0 Specification, Enhanced Host Controller Interface (EHCI) Specification, Version 1.0, and the Open Host Controller Interface (OHCI) Specification, Version 1.0a.

**8.5.2.4. USB Host Register List**

Module Name	Base Address
USB_HCI1	0x01C1B000
USB_HCI2	0x01C1C000
USB_HCI3	0x01C1D000

Register Name	Offset	Description
<b>EHCI Capability Register</b>		
E_CAPLENGTH	0x000	EHCI Capability register Length Register
E_HCVERSION	0x002	EHCI Host Interface Version Number Register
E_HCSPARAMS	0x004	EHCI Host Control Structural Parameter Register
E_HCCPARAMS	0x008	EHCI Host Control Capability Parameter Register
E_HCSPPORTROUTE	0x00c	EHCI Companion Port Route Description
<b>EHCI Operational Register</b>		
E_USBCMD	0x010	EHCI USB Command Register
E_USBSTS	0x014	EHCI USB Status Register
E_USBINTR	0x018	EHCI USB Interrupt Enable Register
E_FRINDEX	0x01c	EHCI USB Frame Index Register
E_CTRLDSSEGMENT	0x020	EHCI 4G Segment Selector Register
E_PERIODICLISTBASE	0x024	EHCI Frame List Base Address Register
E_ASYNCLISTADDR	0x028	EHCI Next Asynchronous List Address Register
E_CONFIGFLAG	0x050	EHCI Configured Flag Register
E_PORTSC	0x054	EHCI Port Status/Control Register
<b>OHCI Control and Status Partition Register</b>		
O_HcRevision	0x400	OHCI Revision Register
O_HcControl	0x404	OHCI Control Register
O_HcCommandStatus	0x408	OHCI Command Status Register
O_HcInterruptStatus	0x40c	OHCI Interrupt Status Register
O_HcInterruptEnable	0x410	OHCI Interrupt Enable Register
O_HcInterruptDisable	0x414	OHCI Interrupt Disable Register
<b>OHCI Memory Pointer Partition Register</b>		
O_HcHCCA	0x418	OHCI HCCA Base
O_HcPeriodCurrentED	0x41c	OHCI Period Current ED Base
O_HcControlHeadED	0x420	OHCI Control Head ED Base
O_HcControlCurrentED	0x424	OHCI Control Current ED Base
O_HcBulkHeadED	0x428	OHCI Bulk Head ED Base
O_HcBulkCurrentED	0x42c	OHCI Bulk Current ED Base
O_HcDoneHead	0x430	OHCI Done Head Base
<b>OHCI Frame Counter Partition Register</b>		
O_HcFmInterval	0x434	OHCI Frame Interval Register
O_HcFmRemaining	0x438	OHCI Frame Remaining Register
O_HcFmNumber	0x43c	OHCI Frame Number Register
O_HcPeriodicStart	0x440	OHCI Periodic Start Register
O_HcLSThreshold	0x444	OHCI LS Threshold Register
<b>OHCI Root Hub Partition Register</b>		
O_HcRhDescriptorA	0x448	OHCI Root Hub Descriptor Register A
O_HcRhDescriptorB	0x44c	OHCI Root Hub Descriptor Register B
O_HcRhStatus	0x450	OHCI Root Hub Status Register
O_HcRhPortStatus	0x454	OHCI Root Hub Port Status Register

### 8.5.2.5. EHCI Register Description

#### 8.5.2.5.1. EHCI Identification Register(Default Value: Implementation Dependent)

Offset: 0x0000			Register Name: <b>CAPLENGTH</b>
Bit	R/W	Default/Hex	Description
7:0	R	0x10	<b>CAPLENGTH</b> The value in these bits indicates an offset to add to register base to find the beginning of the Operational Register Space.

#### 8.5.2.5.2. EHCI Host Interface Version Number Register(Default Value: 0x0100)

Offset: 0x0002			Register Name: <b>HCIVERSION</b>
Bit	R/W	Default/Hex	Description
15:0	R	0x0100	<b>HCIVERSION</b> This is a 16-bits register containing a BCD encoding of the EHCI revision number supported by this host controller. The most significant byte of this register represents a major revision and the least significant byte is the minor revision.

#### 8.5.2.5.3. EHCI Host Control Structural Parameter Register(Default Value: Implementation Dependent)

Offset: 0x0004			Register Name: <b>HCSPARAMS</b>
Bit	R/W	Default/Hex	Description
31:24	/	0	Reserved. These bits are reserved and should be set to zero.
23:20	R	0	<b>Debug Port Number</b> This register identifies which of the host controller ports is the debug port. The value is the port number (one based) of the debug port. This field will always be '0'.
19:16	/	0	Reserved. These bits are reserved and should be set to zero.
15:12	R	0	<b>Number of Companion Controller (N_CC)</b> This field indicates the number of companion controllers associated with this USB2.0 host controller. A zero in this field indicates there are no companion host controllers. And a value larger than zero in this field indicates there are companion USB1.1 host controller(s). This field will always be '0'.
11:8	R	0	<b>Number of Port per Companion Controller(N_PCC)</b> This field indicates the number of ports supported per companion host controller host controller. It is used to indicate the port routing configuration

			to system software. This field will always fix with '0'.						
			<p>Port Routing Rules</p> <p>This field indicates the method used by this implementation for how all ports are mapped to companion controllers. The value of this field has the following interpretation:</p> <table border="1"> <thead> <tr> <th>Value</th> <th>Meaning</th> </tr> </thead> <tbody> <tr> <td>0</td> <td>The first N_PCC ports are routed to the lowest numbered function companion host controller, the next N_PCC port are routed to the next lowest function companion controller, and so on.</td> </tr> <tr> <td>1</td> <td>The port routing is explicitly enumerated by the first N_PORTS elements of the HCSP-PORTROUTE array.</td> </tr> </tbody> </table>	Value	Meaning	0	The first N_PCC ports are routed to the lowest numbered function companion host controller, the next N_PCC port are routed to the next lowest function companion controller, and so on.	1	The port routing is explicitly enumerated by the first N_PORTS elements of the HCSP-PORTROUTE array.
Value	Meaning								
0	The first N_PCC ports are routed to the lowest numbered function companion host controller, the next N_PCC port are routed to the next lowest function companion controller, and so on.								
1	The port routing is explicitly enumerated by the first N_PORTS elements of the HCSP-PORTROUTE array.								
7	R	0	This field will always be '0'.						
6:4	/	0	Reserved. These bits are reserved and should be set to zero.						
3:0	R	1	<p>N_PORTS</p> <p>This field specifies the number of physical downstream ports implemented on this host controller. The value of this field determines how many port registers are addressable in the Operational Register Space. Valid values are in the range of 0x1 to 0x0f.</p> <p>This field is always 1.</p>						

#### 8.5.2.5.4. EHCI Host Control Capability Parameter Register(Default Value: Implementation Dependent)

Offset: 0x0008			Register Name: <b>HCCPARAMS</b>
Bit	R/W	Default/Hex	Description
31:16	/	0	Reserved These bits are reserved and should be set to zero.
15:18	R	0	<p>EHCI Extended Capabilities Pointer (EECP)</p> <p>This optional field indicates the existence of a capabilities list. A value of 00b indicates no extended capabilities are implemented. A non-zero value in this register indicates the offset in PCI configuration space of the first EHCI extended capability. The pointer value must be 40h or greater if implemented to maintain consistency of the PCI header defined for this class of device.</p> <p>The value of this field is always '00b'.</p>
7:4	R		<p>Isochronous Scheduling Threshold</p> <p>This field indicates, relative to the current position of the executing host controller, where software can reliably update the isochronous schedule. When bit[7] is zero, the value of the least significant 3 bits indicates the number of micro-frames a host controller can hold a set of isochronous data structures(one or more) before flushing the state. When bit[7] is a one, then host software assumes the host controller may cache an isochronous data</p>

			structure for an entire frame.
3	R	0	Reserved These bits are reserved and should be set to zero.
2	R		Asynchronous Schedule Park Capability If this bit is set to a one, then the host controller supports the park feature for high-speed queue heads in the Asynchronous Schedule. The feature can be disabled or enabled and set to a specific level by using the Asynchronous Schedule Park Mode Enable and Asynchronous Schedule Park Mode Count fields in the USBCMD register.
1	R		Programmable Frame List Flag If this bit is set to a zero, then system software must use a frame list length of 1024 elements with this host controller. The USBCMD register Frame List Size field is a read-only register and should be set to zero. If set to 1, then system software can specify and use the frame list in the USBCMD register Frame List Size field to configure the host controller. The frame list must always be aligned on a 4K page boundary. This requirement ensures that the frame list is always physically contiguous.
0	R	0	Reserved These bits are reserved for future use and should return a value of zero when read.

#### 8.5.2.5.5. EHCI Companion Port Route Description (Default Value: UNDEFINED)

Offset: 0x000C			Register Name: <b>HCSP-PORTROUTE</b>
Bit	R/W	Default/Hex	Description
31:0	R		<p>HCSP-PORTROUTE</p> <p>This optional field is valid only if Port Routing Rules field in HCSPARAMS register is set to a one.</p> <p>This field is used to allow a host controller implementation to explicitly describe to which companion host controller each implemented port is mapped. This field is a 15-element nibble array (each 4 bit is one array element). Each array location corresponds one-to-one with a physical port provided by the host controller (e.g. PORTROUTE [0] corresponds to the first PORTSC port, PORTROUTE [1] to the second PORTSC port, etc.). The value of each element indicates to which of the companion host controllers this port is routed. Only the first N_PORTS elements have valid information. A value of zero indicates that the port is routed to the lowest numbered function companion host controller. A value of one indicates that the port is routed to the next lowest numbered function companion host controller, and so on.</p>



**8.5.2.5.6. EHCI USB Command Register (Default Value: 0x00080000, 0x00080B00 if Asynchronous Schedule Park**
**Capability is a one)**

Offset: 0x0010			Register Name: <b>USBCMD</b>																		
Bit	R/W	Default/Hex	Description																		
31:24	/	0	Reserved These bits are reserved and should be set to zero.																		
23:16	R/W	0x08	<p>Interrupt Threshold Control The value in this field is used by system software to select the maximum rate at which the host controller will issue interrupts. The only valid values are defined below:</p> <table border="1"> <thead> <tr> <th>Value</th> <th>Minimum Interrupt Interval</th> </tr> </thead> <tbody> <tr> <td>0x00</td> <td>Reserved</td> </tr> <tr> <td>0x01</td> <td>1 micro-frame</td> </tr> <tr> <td>0x02</td> <td>2 micro-frame</td> </tr> <tr> <td>0x04</td> <td>4 micro-frame</td> </tr> <tr> <td>0x08</td> <td>8 micro-frame(default, equates to 1 ms)</td> </tr> <tr> <td>0x10</td> <td>16 micro-frame(2ms)</td> </tr> <tr> <td>0x20</td> <td>32 micro-frame(4ms)</td> </tr> <tr> <td>0x40</td> <td>64 micro-frame(8ms)</td> </tr> </tbody> </table> <p>Any other value in this register yields undefined results. The default value in this field is 0x08 . Software modifications to this bit while HC Halted bit is equal to zero results in undefined behavior.</p>	Value	Minimum Interrupt Interval	0x00	Reserved	0x01	1 micro-frame	0x02	2 micro-frame	0x04	4 micro-frame	0x08	8 micro-frame(default, equates to 1 ms)	0x10	16 micro-frame(2ms)	0x20	32 micro-frame(4ms)	0x40	64 micro-frame(8ms)
Value	Minimum Interrupt Interval																				
0x00	Reserved																				
0x01	1 micro-frame																				
0x02	2 micro-frame																				
0x04	4 micro-frame																				
0x08	8 micro-frame(default, equates to 1 ms)																				
0x10	16 micro-frame(2ms)																				
0x20	32 micro-frame(4ms)																				
0x40	64 micro-frame(8ms)																				
15:12	/	0	Reserved These bits are reserved and should be set to zero.																		
11	R/W or R	0	Asynchronous Schedule Park Mode Enable(OPTIONAL) If the Asynchronous Park Capability bit in the HCCPARAMS register is a one, then this bit defaults to a 1 and is R/W. Otherwise the bit must be a zero and is Read Only. Software uses this bit to enable or disable Park mode. When this bit is one, Park mode is enabled. When this bit is zero, Park mode is disabled.																		
10	/	0	Reserved These bits are reserved and should be set to zero.																		
9:8	R/W or R	0	Asynchronous Schedule Park Mode Count(OPTIONAL) Asynchronous Park Capability bit in the HCCPARAMS register is a one, Then this field defaults to 0x3 and is W/R. Otherwise it defaults to zero and is R. It contains a count of the number of successive transactions the host controller is allowed to execute from a high-speed queue head on the Asynchronous schedule before continuing traversal of the Asynchronous schedule. Valid value are 0x1 to 0x3. Software must not write a zero to this bit when Park Mode Enable is a one as it will result in undefined behavior.																		

7	R/W	0	<p>Light Host Controller Reset(OPTIONAL)</p> <p>This control bit is not required.</p> <p>If implemented, it allows the driver to reset the EHCI controller without affecting the state of the ports or relationship to the companion host controllers. For example, the PORSTC registers should not be reset to their default values and the CF bit setting should not go to zero (retaining port ownership relationships).</p> <p>A host software read of this bit as zero indicates the Light Host Controller Reset has completed and it is safe for software to re-initialize the host controller. A host software read of this bit as a one indicates the Light Host</p>						
6	R/W	0	<p>Interrupt on Async Advance Doorbell</p> <p>This bit is used as a doorbell by software to tell the host controller to issue an interrupt the next time it advances asynchronous schedule. Software must write a 1 to this bit to ring the doorbell.</p> <p>When the host controller has evicted all appropriate cached schedule state, it sets the Interrupt on Async Advance status bit in the USBSTS. If the Interrupt on Async Advance Enable bit in the USBINTR register is a one then the host controller will assert an interrupt at the next interrupt threshold. The host controller sets this bit to a zero after it has set the Interrupt on Async Advance status bit in the USBSTS register to a one.</p> <p>Software should not write a one to this bit when the asynchronous schedule is disabled. Doing so will yield undefined results.</p>						
5	R/W	0	<p>Asynchronous Schedule Enable</p> <p>This bit controls whether the host controller skips processing the Asynchronous Schedule. Values mean:</p> <table border="1"> <thead> <tr> <th>Bit Value</th> <th>Meaning</th> </tr> </thead> <tbody> <tr> <td>0</td> <td>Do not process the Asynchronous Schedule.</td> </tr> <tr> <td>1</td> <td>Use the ASYNLISTADDR register to access the Asynchronous Schedule.</td> </tr> </tbody> </table> <p>The default value of this field is '0b'.</p>	Bit Value	Meaning	0	Do not process the Asynchronous Schedule.	1	Use the ASYNLISTADDR register to access the Asynchronous Schedule.
Bit Value	Meaning								
0	Do not process the Asynchronous Schedule.								
1	Use the ASYNLISTADDR register to access the Asynchronous Schedule.								
4	R/W	0	<p>Periodic Schedule Enable</p> <p>This bit controls whether the host controller skips processing the Periodic Schedule. Values mean:</p> <table border="1"> <thead> <tr> <th>Bit Value</th> <th>Meaning</th> </tr> </thead> <tbody> <tr> <td>0</td> <td>Do not process the Periodic Schedule.</td> </tr> <tr> <td>1</td> <td>Use the PERIODICLISTBASE register to access the Periodic Schedule.</td> </tr> </tbody> </table> <p>The default value of this field is '0b'.</p>	Bit Value	Meaning	0	Do not process the Periodic Schedule.	1	Use the PERIODICLISTBASE register to access the Periodic Schedule.
Bit Value	Meaning								
0	Do not process the Periodic Schedule.								
1	Use the PERIODICLISTBASE register to access the Periodic Schedule.								
3:2	R/W or R	0	<p>Frame List Size</p> <p>This field is R/W only if Programmable Frame List Flag in the HCCPARAMS registers is set to a one. This field specifies the size of the Frame list. The size the frame list controls which bits in the Frame Index Register should be used for the Frame List Current index. Values mean:</p> <table border="1"> <thead> <tr> <th>Bits</th> <th>Meaning</th> </tr> </thead> <tbody> <tr> <td>00b</td> <td>1024 elements(4096bytes)Default</td> </tr> </tbody> </table>	Bits	Meaning	00b	1024 elements(4096bytes)Default		
Bits	Meaning								
00b	1024 elements(4096bytes)Default								

			<table border="1"> <tr> <td>01b</td> <td>512 elements(2048bytes)</td> </tr> <tr> <td>10b</td> <td>256 elements(1024bytes)For resource-constrained condition</td> </tr> <tr> <td>11b</td> <td>reserved</td> </tr> </table> <p>The default value is '00b'.</p>	01b	512 elements(2048bytes)	10b	256 elements(1024bytes)For resource-constrained condition	11b	reserved
01b	512 elements(2048bytes)								
10b	256 elements(1024bytes)For resource-constrained condition								
11b	reserved								
1	R/W	0	<p><b>Host Controller Reset</b></p> <p>This control bit is used by software to reset the host controller. The effects of this on Root Hub registers are similar to a Chip Hardware Reset. When software writes a one to this bit, the Host Controller resets its internal pipelines, timers, counters, state machines, etc. to their initial value. Any transaction currently in progress on USB is immediately terminated. A USB reset is not driven on downstream ports.</p> <p>All operational registers, including port registers and port state machines are set to their initial values. Port ownership reverts to the companion host controller(s). Software must reinitialize the host controller as described in Section 4.1 of the CHEI Specification in order to return the host controller to an operational state.</p> <p>This bit is set to zero by the Host Controller when the reset process is complete. Software cannot terminate the reset process early by writing a zero to this register.</p> <p>Software should not set this bit to a one when the HC Halted bit in the USBSTS register is a zero. Attempting to reset an actively running host controller will result in undefined behavior.</p>						
0	R/W	0	<p><b>Run/Stop</b></p> <p>When set to a 1, the Host Controller proceeds with execution of the schedule. When set to 0, the Host Controller completes the current and any actively pipelined transactions on the USB and then halts. The Host Controller must halt within 16 micro-frames after software clears this bit. The HC Halted bit indicates when the Host Controller has finished its pending pipelined transactions and has entered the stopped state. Software must not write a one to this field unless the Host Controller is in the Halt State.</p> <p>The default value is 0x0.</p>						

#### 8.5.2.5.7. EHCI USB Status Register (Default Value: 0x00001000)

Offset: 0x0014			Register Name: <b>USBSTS</b>
Bit	R/W	Default/Hex	Description
31:16	/	0	Reserved These bits are reserved and should be set to zero.
15	R	0	Asynchronous Schedule Status The bit reports the current real status of Asynchronous Schedule. If this bit is a zero then the status of the Asynchronous Schedule is disabled. If this bit is a one then the status of the Asynchronous Schedule is enabled. The Host

			Controller is not required to immediately disable or enable the Asynchronous Schedule when software transitions the Asynchronous Schedule Enable bit in the USBCMD register. When this bit and the Asynchronous Schedule Enable bit are the same value, the Asynchronous Schedule is either enabled (1) or disabled (0).
14	R	0	<p><b>Periodic Schedule Status</b></p> <p>The bit reports the current real status of the Periodic Schedule. If this bit is a zero then the status of the Periodic Schedule is disabled. If this bit is a one then the status of the Periodic Schedule is enabled. The Host Controller is not required to immediately disable or enable the Periodic Schedule when software transitions the Periodic Schedule Enable bit in the USBCMD register. When this bit and the Periodic Schedule Enable bit are the same value, the Periodic Schedule is either enabled (1) or disabled (0).</p>
13	R	0	<p><b>Reclamation</b></p> <p>This is a read-only status bit, which is used to detect an empty asynchronous schedule.</p>
12	R	1	<p><b>HC Halted</b></p> <p>This bit is a zero whenever the Run/Stop bit is a one. The Host Controller Sets this bit to one after it has stopped executing as a result of the Run/Stop bit being set to 0, either by software or by the Host Controller Hardware (e.g. internal error). The default value is '1'.</p>
11:6	/	0	<p><b>Reserved</b></p> <p>These bits are reserved and should be set to zero.</p>
5	R/WC	0	<p><b>Interrupt on Async Advance</b></p> <p>System software can force the host controller to issue an interrupt the next time the host controller advances the asynchronous schedule by writing a one to the Interrupt on Async Advance Doorbell bit in the USBCMD register. This status bit indicates the assertion of that interrupt source.</p>
4	R/WC	0	<p><b>Host System Error</b></p> <p>The Host Controller set this bit to 1 when a serious error occurs during a host system access involving the Host Controller module. When this error occurs, the Host Controller clears the Run/Stop bit in the Command register to prevent further execution of the scheduled TDs.</p>
3	R/WC	0	<p><b>Frame List Rollover</b></p> <p>The Host Controller sets this bit to a one when the Frame List Index rolls over from its maximum value to zero. The exact value at which the rollover occurs depends on the frame list size. For example, if the frame list size is 1024, the Frame Index Register rolls over every time FRINDEX [13] toggles. Similarly, if the size is 512, the Host Controller sets this bit to a one every time FRINDEX [12] toggles.</p>
2	R/WC	0	<p><b>Port Change Detect</b></p> <p>The Host Controller sets this bit to a one when any port for which the Port Owner bit is set to zero has a change bit transition from a zero to a one or a Force Port Resume bit transition from a zero to a one as a result of a J-K</p>

			transition detected on a suspended port. This bit will also be set as a result of the Connect Status Chang being set to a one after system software has relinquished ownership of a connected port by writing a one to a port's Port Owner bit.
1	R/WC	0	<p>USB Error Interrupt(USBERRINT)</p> <p>The Host Controller sets this bit to 1 when completion of USB transaction results in an error condition(e.g. error counter underflow).If the TD on which the error interrupt occurred also had its IOC bit set, both. This bit and USBINT bit are set.</p>
0	R/WC	0	<p>USB Interrupt(USBINT)</p> <p>The Host Controller sets this bit to a one on the completion of a USB transaction, which results in the retirement of a Transfer Descriptor that had its IOC bit set.</p> <p>The Host Controller also sets this bit to 1 when a short packet is detected (actual number of bytes received was less than the expected number of bytes)</p>

#### 8.5.2.5.8. EHCI USB Interrupt Enable Register (Default Value: 0x00000000)

Offset: 0x0018			Register Name: <b>USBINTR</b>
Bit	R/W	Default/Hex	Description
31:6	/	0	<p>Reserved</p> <p>These bits are reserved and should be zero.</p>
5	R/W	0	<p>Interrupt on Async Advance Enable</p> <p>When this bit is 1, and the Interrupt on Async Advance bit in the USBSTS register is 1, the host controller will issue an interrupt at the next interrupt threshold. The interrupt is acknowledged by software clearing the Interrupt on Async Advance bit.</p>
4	R/W	0	<p>Host System Error Enable</p> <p>When this bit is 1, and the Host System Error Status bit in the USBSTS register is 1, the host controller will issue an interrupt. The interrupt is acknowledged by software clearing the Host System Error bit.</p>
3	R/W	0	<p>Frame List Rollover Enable</p> <p>When this bit is 1, and the Frame List Rollover bit in the USBSTS register is 1, the host controller will issue an interrupt. The interrupt is acknowledged by software clearing the Frame List Rollover bit.</p>
2	R/W	0	<p>Port Change Interrupt Enable</p> <p>When this bit is 1, and the Port Chang Detect bit in the USBSTS register is 1, the host controller will issue an interrupt. The interrupt is acknowledged by software clearing the Port Chang Detect bit.</p>
1	R/W	0	<p>USB Error Interrupt Enable</p> <p>When this bit is 1, and the USBERRINT bit in the USBSTS register is 1,the host controller will issue an interrupt at the next interrupt threshold. The interrupt is acknowledged by software clearing the USBERRINT bit.</p>

0	R/W	0	<p>USB Interrupt Enable</p> <p>When this bit is 1, and the USBINT bit in the USBSTS register is 1, the host controller will issue an interrupt at the next interrupt threshold.</p> <p>The interrupt is acknowledged by software clearing the USBINT bit</p>
---	-----	---	--

#### 8.5.2.5.9. EHCI Frame Index Register (Default Value: 0x00000000)

Offset: 0x001C			Register Name: <b>FRINDEX</b>															
Bit	R/W	Default/Hex	Description															
31:14	/	0	<p>Reserved</p> <p>These bits are reserved and should be zero.</p>															
13:0	R/W	0	<p>Frame Index</p> <p>The value in this register increment at the end of each time frame (e.g. micro-frame). Bits[N:3] are used for the Frame List current index. It Means that each location of the frame list is accessed 8 times(frames or Micro-frames) before moving to the next index. The following illustrates Values of N based on the value of the Frame List Size field in the USBCMD register.</p> <table border="1" data-bbox="592 999 1417 1223"> <thead> <tr> <th>USBCMD[Frame List Size]</th> <th>Number Elements</th> <th>N</th> </tr> </thead> <tbody> <tr> <td>00b</td> <td>1024</td> <td>12</td> </tr> <tr> <td>01b</td> <td>512</td> <td>11</td> </tr> <tr> <td>10b</td> <td>256</td> <td>10</td> </tr> <tr> <td>11b</td> <td>Reserved</td> <td></td> </tr> </tbody> </table>	USBCMD[Frame List Size]	Number Elements	N	00b	1024	12	01b	512	11	10b	256	10	11b	Reserved	
			USBCMD[Frame List Size]	Number Elements	N													
			00b	1024	12													
			01b	512	11													
			10b	256	10													
11b	Reserved																	

Note: This register must be written as a DWord. Byte writes produce undefined results.

#### 8.5.2.5.10. EHCI Periodic Frame List Base Address Register (Default Value: Undefined)

Offset: 0x0024			Register Name: <b>PERIODICLISTBASE</b>
Bit	R/W	Default/Hex	Description
31:12	R/W		<p>Base Address</p> <p>These bits correspond to memory address signals [31:12], respectively.</p> <p>This register contains the beginning address of the Periodic Frame List in the system memory.</p> <p>System software loads this register prior to starting the schedule execution by the Host Controller. The memory structure referenced by this physical memory pointer is assumed to be 4-K byte aligned. The contents of this register are combined with the Frame Index Register (FRINDEX) to enable the Host Controller to step through the Periodic Frame List in sequence.</p>
11:0	/		<p>Reserved</p> <p>Must be written as 0x0 during runtime, the values of these bits are undefined.</p>

Note: Writes must be Dword Writes.

**8.5.2.5.11. EHCI Current Asynchronous List Address Register (Default Value: Undefined)**

Offset: 0x0028			Register Name: <b>ASYNCLISTADDR</b>
Bit	R/W	Default/Hex	Description
31:5	R/W		<p>Link Pointer (LP) This field contains the address of the next asynchronous queue head to be executed. These bits correspond to memory address signals [31:5], respectively.</p>
4:0	/	/	<p>Reserved These bits are reserved and their value has no effect on operation. Bits in this field cannot be modified by system software and will always return a zero when read.</p>

Note: Write must be DWord Writes.

**8.5.2.5.12. EHCI Configure Flag Register (Default Value: 0x00000000)**

Offset: 0x0050			Register Name: <b>CONFIGFLAG</b>						
Bit	R/W	Default/Hex	Description						
31:1	/	0	<p>Reserved These bits are reserved and should be set to zero.</p>						
0	R/W	0	<p>Configure Flag(CF) Host software sets this bit as the last action in its process of configuring the Host Controller. This bit controls the default port-routing control logic as follow:</p> <table border="1" style="width: 100%; border-collapse: collapse;"> <thead> <tr> <th style="width: 15%;">Value</th> <th>Meaning</th> </tr> </thead> <tbody> <tr> <td style="text-align: center;">0</td> <td>Port routing control logic default-routs each port to an implementation dependent classic host controller.</td> </tr> <tr> <td style="text-align: center;">1</td> <td>Port routing control logic default-routs all ports to this host controller.</td> </tr> </tbody> </table> <p>The default value of this field is '0'.</p>	Value	Meaning	0	Port routing control logic default-routs each port to an implementation dependent classic host controller.	1	Port routing control logic default-routs all ports to this host controller.
Value	Meaning								
0	Port routing control logic default-routs each port to an implementation dependent classic host controller.								
1	Port routing control logic default-routs all ports to this host controller.								

Note: This register is not use in the normal implementation.

**8.5.2.5.13. EHCI Port Status and Control Register (Default Value: 0x00002000(w/PPC set to one);0x00003000**

**(w/PPC set to a zero))**

Offset: 0x0054			Register Name: <b>PORTSC</b>
Bit	R/W	Default/Hex	Description

31:22	/	0	Reserved These bits are reserved for future use and should return a value of zero when read.																		
21	R/W	0	Wake on Disconnect Enable(WKDSCNNT_E) Writing this bit to a one enables the port to be sensitive to device disconnects as wake-up events. This field is zero if Port Power is zero. The default value in this field is '0'.																		
20	R/W	0	Wake on Connect Enable(WKCNNT_E) Writing this bit to a one enable the port to be sensitive to device connects as wake-up events. This field is zero if Port Power is zero. The default value in this field is '0'.																		
19:16	R/W	0	Port Test Control The value in this field specifies the test mode of the port. The encoding of the test mode bits are as follow: <table border="1" data-bbox="592 857 1423 1296"> <thead> <tr> <th>Bits</th> <th>Test Mode</th> </tr> </thead> <tbody> <tr> <td>0000b</td> <td>The port is NOT operating in a test mode.</td> </tr> <tr> <td>0001b</td> <td>Test J_STATE</td> </tr> <tr> <td>0010b</td> <td>Test K_STATE</td> </tr> <tr> <td>0011b</td> <td>Test SEO_NAK</td> </tr> <tr> <td>0100b</td> <td>Test Packet</td> </tr> <tr> <td>0101b</td> <td>Test FORCE_ENABLE</td> </tr> <tr> <td>0110b</td> <td>-</td> </tr> <tr> <td>1111b</td> <td>Reserved</td> </tr> </tbody> </table> The default value in this field is '0000b'.	Bits	Test Mode	0000b	The port is NOT operating in a test mode.	0001b	Test J_STATE	0010b	Test K_STATE	0011b	Test SEO_NAK	0100b	Test Packet	0101b	Test FORCE_ENABLE	0110b	-	1111b	Reserved
Bits	Test Mode																				
0000b	The port is NOT operating in a test mode.																				
0001b	Test J_STATE																				
0010b	Test K_STATE																				
0011b	Test SEO_NAK																				
0100b	Test Packet																				
0101b	Test FORCE_ENABLE																				
0110b	-																				
1111b	Reserved																				
15:14	R/W	0	Reserved These bits are reserved for future use and should return a value of zero when read.																		
13	R/W	1	Port Owner This bit unconditionally goes to a 0b when the Configured bit in the CONFIGFLAG register makes a 0b to 1b transition. This bit unconditionally goes to 1b whenever the Configured bit is zero. System software uses this field to release ownership of the port to selected host controller (in the event that the attached device is not a high-speed device).Software writes a one to this bit when the attached device is not a high-speed device. A one in this bit means that a companion host controller owns and controls the port. Default Value = 1b.																		
12	/	0	Reserved These bits are reserved for future use and should return a value of zero when read.																		
11:10	R	0	Line Status These bits reflect the current logical levels of the D+ (bit11) and D-(bit10)																		



			<p>signal lines. These bits are used for detection of low-speed USB devices prior to port reset and enable sequence. This read only field is valid only when the port enable bit is zero and the current connect status bit is set to a one. The encoding of the bits are:</p> <table border="1"> <thead> <tr> <th>Bit[11:10]</th> <th>USB State</th> <th>Interpretation</th> </tr> </thead> <tbody> <tr> <td>00b</td> <td>SE0</td> <td>Not Low-speed device, perform EHCI reset.</td> </tr> <tr> <td>10b</td> <td>J-state</td> <td>Not Low-speed device, perform EHCI reset.</td> </tr> <tr> <td>01b</td> <td>K-state</td> <td>Low-speed device, release ownership of port.</td> </tr> <tr> <td>11b</td> <td>Undefined</td> <td>Not Low-speed device, perform EHCI reset.</td> </tr> </tbody> </table> <p>This value of this field is undefined if Port Power is zero.</p>	Bit[11:10]	USB State	Interpretation	00b	SE0	Not Low-speed device, perform EHCI reset.	10b	J-state	Not Low-speed device, perform EHCI reset.	01b	K-state	Low-speed device, release ownership of port.	11b	Undefined	Not Low-speed device, perform EHCI reset.
Bit[11:10]	USB State	Interpretation																
00b	SE0	Not Low-speed device, perform EHCI reset.																
10b	J-state	Not Low-speed device, perform EHCI reset.																
01b	K-state	Low-speed device, release ownership of port.																
11b	Undefined	Not Low-speed device, perform EHCI reset.																
9	/	0	<p>Reserved</p> <p>This bit is reserved for future use, and should return a value of zero when read.</p>															
8	R/W	0	<p>Port Reset</p> <p>1=Port is in Reset. 0=Port is not in Reset. Default = 0.</p> <p>When software writes a one to this bit (from a zero), the bus reset sequence as defined in the USB Specification Revision 2.0 is started. Software writes a zero to this bit to terminate the bus reset sequence. Software must keep this bit at a one long enough to ensure the reset sequence, as specified in the USB Specification Revision 2.0, completes. Notes: when software writes this bit to a one , it must also write a zero to the Port Enable bit.</p> <p>Note that when software writes a zero to this bit there may be a delay before the bit status changes to a zero. The bit status will not read as a zero until after the reset has completed. If the port is in high-speed mode after reset is complete, the host controller will automatically enable this port (e.g. set the Port Enable bit to a one). A host controller must terminate the reset and stabilize the state of the port within 2 milliseconds of software transitioning this bit from a one to a zero. For example: if the port detects that the attached device is high-speed during reset, then the host controller must have the port in the enabled state with 2ms of software writing this bit to a zero.</p> <p>The HC Halted bit in the USBSTS register should be a zero before software attempts to use this bit. The host controller may hold Port Reset asserted to a one when the HC Halted bit is a one.</p> <p>This field is zero if Port Power is zero.</p>															
7	R/W	0	<p>Suspend</p> <p>Port Enabled Bit and Suspend bit of this register define the port states as follows:</p> <table border="1"> <thead> <tr> <th>Bits[Port Enables, Suspend]</th> <th>Port State</th> </tr> </thead> <tbody> <tr> <td>0x</td> <td>Disable</td> </tr> <tr> <td>10</td> <td>Enable</td> </tr> </tbody> </table>	Bits[Port Enables, Suspend]	Port State	0x	Disable	10	Enable									
Bits[Port Enables, Suspend]	Port State																	
0x	Disable																	
10	Enable																	

			<table border="1"> <tr> <td>11</td> <td>Suspend</td> </tr> </table> <p>When in suspend state, downstream propagation of data is blocked on this port, except for port reset. The blocking occurs at the end of the current transaction, if a transaction was in progress when this bit was written to 1. In the suspend state, the port is sensitive to resume detection. Not that the bit status does not change until the port is suspend and that there may be a delay in suspending a port if there is a transaction currently in progress on the USB.</p> <p>A write of zero to this bit is ignored by the host controller. The host controller will unconditionally set this bit to a zero when:</p> <ol style="list-style-type: none"> <li>① Software sets the Force Port Resume bit to a zero(from a one).</li> <li>② Software sets the Port Reset bit to a one(from a zero).</li> </ol> <p>If host software sets this bit to a one when the port is not enabled(i.e. Port enabled bit is a zero), the results are undefined.</p> <p>This field is zero if Port Power is zero.</p> <p>The default value in this field is '0'.</p>	11	Suspend
11	Suspend				
6	R/W	0	<p><b>Force Port Resume</b> 1 = Resume detected/driven on port. 0 = No resume (K-state) detected/driven on port. Default = 0.</p> <p>This functionality defined for manipulating this bit depends on the value of the Suspend bit. For example, if the port is not suspend and software transitions this bit to a one, then the effects on the bus are undefined. Software sets this bit to a 1 drive resume signaling. The Host Controller sets this bit to a 1 if a J-to-K transition is detected while the port is in the Suspend state. When this bit transitions to a one because a J-to-K transition is detected, the Port Change Detect bit in the USBSTS register is also set to a one. If software sets this bit to a one, the host controller must not set the Port Change Detect bit.</p> <p>Note that when the EHCI controller owns the port, the resume sequence follows the defined sequence documented in the USB Specification Revision 2.0. The resume signaling (Full-speed 'K') is driven on the port as long as this remains a one. Software must appropriately time the Resume and set this bit to a zero when the appropriate amount of time has elapsed. Writing a zero (from one) causes the port to return high-speed mode (forcing the bus below the port into a high-speed idle). This bit will remain a one until the port has switched to high-speed idle. The host controller must complete this transition within 2 milliseconds of software setting this bit to a zero.</p> <p>This field is zero if Port Power is zero.</p>		
5	R/WC	0	<p><b>Over-current Change</b> Default = 0. This bit gets set to a one when there is a change to Over-current Active. Software clears this bit by writing a one to this bit position.</p>		
4	R	0	<p><b>Over-current Active</b> 0 = This port does not have an over-current condition. 1 = This port currently has an over-current condition. This bit will automatically transition from a one to a zero when the over current condition is removed.</p>		

			The default value of this bit is '0'.
3	R/WC	0	<p>Port Enable/Disable Change Default = 0. 1 = Port enabled/disabled status has changed. 0 = No change. For the root hub, this bit gets set to a one only when a port is disabled due to the appropriate conditions existing at the EOF2 point (See Chapter 11 of the USB Specification for the definition of a Port Error). Software clears this bit by writing a 1 to it. This field is zero if Port Power is zero.</p>
2	R/W	0	<p>Port Enabled/Disabled 1=Enable, 0=Disable. Ports can only be enabled by the host controller as a part of the reset and enable. Software cannot enable a port by writing a one to this field. The host controller will only set this bit to a one when the reset sequence determines that the attached device is a high-speed device. Ports can be disabled by either a fault condition(disconnect event or other fault condition) or by host software. Note that the bit status does not change until the port state actually changes. There may be a delay in disabling or enabling a port due to other host controller and bus events. When the port is disabled, downstream propagation of data is blocked on this port except for reset. The default value of this field is '0'. This field is zero if Port Power is zero.</p>
1	R/WC	0	<p>Connect Status Change 1=Change in Current Connect Status, 0=No change, Default=0. Indicates a change has occurred in the port's Current Connect Status. The host controller sets this bit for all changes to the port device connect status, even if system software has not cleared an existing connect status change. For example, the insertion status changes twice before system software has cleared the changed condition, hub hardware will be "setting" an already-set bit. Software sets this bit to 0 by writing a 1 to it. This field is zero if Port Power is zero.</p>
0	R	0	<p>Current Connect Status Device is present on port when the value of this field is a one, and no device is present on port when the value of this field is a zero. This value reflects the current state of the port, and may not correspond directly to the event that caused the Connect Status Change(Bit 1) to be set. This field is zero if Port Power zero.</p>

Note: This register is only reset by hardware or in response to a host controller reset.

### 8.5.2.6. OHCI Register Description

**8.5.2.6.1. HcRevision Register(Default Value: 0x00000010)**

Offset: 0x400				Register Name: <b>HcRevision</b>
Bit	Read/Write		Default/Hex	Description
	HCD	HC		
31:8	/	/	0x00	Reserved
7:0	R	R	0x10	<p>Revision</p> <p>This read-only field contains the BCD representation of the version of the HCI specification that is implemented by this HC. For example, a value of 0x11 corresponds to version 1.1. All of the HC implementations that are compliant with this specification will have a value of 0x10.</p>

**8.5.2.6.2. HcControl Register(Default Value: 0x00000000)**

Offset: 0x404				Register Name: <b>HcRevision</b>						
Bit	Read/Write		Default/Hex	Description						
	HCD	HC								
31:11	/	/	0x00	Reserved						
10	R/W	R	0x0	<p>RemoteWakeupEnable</p> <p>This bit is used by HCD to enable or disable the remote wakeup feature upon the detection of upstream resume signaling. When this bit is set and the ResumeDetected bit in HcInterruptStatus is set, a remote wakeup is signaled to the host system. Setting this bit has no impact on the generation of hardware interrupt.</p>						
9	R/W	R/W	0x0	<p>RemoteWakeupConnected</p> <p>This bit indicates whether HC supports remote wakeup signaling. If remote wakeup is supported and used by the system, it is the responsibility of system firmware to set this bit during POST. HC clear the bit upon a hardware reset but does not alter it upon a software reset. Remote wakeup signaling of the host system is host-bus-specific and is not described in this specification.</p>						
8	R/W	R	0x0	<p>InterruptRouting</p> <p>This bit determines the routing of interrupts generated by events registered in HcInterruptStatus. If clear, all interrupt are routed to the normal host bus interrupt mechanism. If set interrupts are routed to the System Management Interrupt. HCD clears this bit upon a hardware reset, but it does not alter this bit upon a software reset. HCD uses this bit as a tag to indicate the ownership of HC.</p>						
7:6	R/W	R/W	0x0	<p>HostControllerFunctionalState for USB</p> <table border="1" style="width: 100%; border-collapse: collapse;"> <tr> <td style="width: 20px;">00b</td> <td>USBReset</td> </tr> <tr> <td>01b</td> <td>USBResume</td> </tr> <tr> <td>10b</td> <td>USBOperational</td> </tr> </table>	00b	USBReset	01b	USBResume	10b	USBOperational
00b	USBReset									
01b	USBResume									
10b	USBOperational									

				<table border="1"> <tr> <td>11b</td> <td>USBSuspend</td> </tr> </table> <p>A transition to USBOperational from another state causes SOF generation to begin 1 ms later. HCD may determine whether HC has begun sending SOFs by reading the StartoFrame field of HcInterruptStatus.</p> <p>This field may be changed by HC only when in the USBSUSPEND state. HC may move from the USBSUSPEND state to the USBRESUME state after detecting the resume signaling from a downstream port.</p> <p>HC enters USBSUSPEND after a software reset, whereas it enters USBRESET after a hardware reset. The latter also resets the Root Hub and asserts subsequent reset signaling to downstream ports.</p>	11b	USBSuspend
11b	USBSuspend					
5	R/W	R	0x0	<p><b>BulkListEnable</b></p> <p>This bit is set to enable the processing of the Bulk list in the next Frame. If cleared by HCD, processing of the Bulk list does not occur after the next SOF. HC checks this bit whenever it determines to process the list. When disabled, HCD may modify the list. If HcBulkCurrentED is pointing to an ED to be removed, HCD must advance the pointer by updating HcBulkCurrentED before re-enabling processing of the list.</p>		
4	R/W	R	0x0	<p><b>ControlListEnable</b></p> <p>This bit is set to enable the processing of the Control list in the next Frame. If cleared by HCD, processing of the Control list does not occur after the next SOF. HC must check this bit whenever it determines to process the list. When disabled, HCD may modify the list. If HcControlCurrentED is pointing to an ED to be removed, HCD must advance the pointer by updating HcControlCurrentED before re-enabling processing of the list.</p>		
3	R/W	R	0x0	<p><b>IsochronousEnable</b></p> <p>This bit is used by HCD to enable/disable processing of isochronous EDs. While processing the periodic list in a Frame, HC checks the status of this bit when it finds an Isochronous ED (F=1). If set (enabled), HC continues processing the EDs. If cleared (disabled), HC halts processing of the periodic list (which now contains only isochronous EDs) and begins processing the Bulk/Control lists.</p> <p>Setting this bit is guaranteed to take effect in the next Frame (not the current Frame).</p>		
2	R/W	R	0x0	<p><b>PeriodicListEnable</b></p> <p>This bit is set to enable the processing of periodic list in the next Frame. If cleared by HCD, processing of the periodic list does not occur after the next SOF. HC must check this bit before it starts processing the list.</p>		
1:0	R/W	R	0x0	<p><b>ControlBulkServiceRatio</b></p> <p>This specifies the service ratio between Control and Bulk EDs. Before processing any of the nonperiodic lists, HC must compare the ratio specified with its internal count on how many nonempty Control EDs have been processed, in determining whether to continue serving another Control ED or switching to Bulk EDs. The internal count will be retained when crossing the frame boundary. In case of reset, HCD is responsible for</p>		

				restoring this value.										
				<table border="1"> <thead> <tr> <th>CBSR</th> <th>No. of Control EDs Over Bulk EDs Served</th> </tr> </thead> <tbody> <tr> <td>0</td> <td>1:1</td> </tr> <tr> <td>1</td> <td>2:1</td> </tr> <tr> <td>2</td> <td>3:1</td> </tr> <tr> <td>3</td> <td>4:1</td> </tr> </tbody> </table>	CBSR	No. of Control EDs Over Bulk EDs Served	0	1:1	1	2:1	2	3:1	3	4:1
CBSR	No. of Control EDs Over Bulk EDs Served													
0	1:1													
1	2:1													
2	3:1													
3	4:1													
				The default value is 0x0.										

**8.5.2.6.3. HcCommandStatus Register(Default Value: 0x00000000)**

Offset: 0x408				Register Name: <b>HcCommandStatus</b>
Bit	Read/Write		Default/Hex	Description
	HCD	HC		
31:18	/	/	0x0	Reserved
17:16	R	R/W	0x0	<b>SchedulingOverrunCount</b> These bits are incremented on each scheduling overrun error. It is initialized to 00b and wraps around at 11b. This will be incremented when a scheduling overrun is detected even if SchedulingOverrun in HcInterruptStatus has already been set. This is used by HCD to monitor any persistent scheduling problem.
15:4	/	/	0x0	Reserved
3	R/W	R/W	0x0	<b>OwenshipChangeRequest</b> This bit is set by an OS HCD to request a change of control of the HC. When set HC will set the OwenshipChange field in HcInterruptStatus. After the changeover, this bit is cleared and remains so until the next request from OS HCD.
2	R/W	R/W	0x0	<b>BulkListFilled</b> This bit is used to indicate whether there are any TDs on the Bulk list. It is set by HCD whenever it adds a TD to an ED in the Bulk list. When HC begins to process the head of the Bulk list, it checks BLF. As long as BulkListFilled is 0, HC will not start processing the Bulk list. If BulkListFilled is 1, HC will start processing the Bulk list and will set BF to 0. If HC finds a TD on the list, then HC will set BulkListFilled to 1 causing the Bulk list processing to continue. If no TD is found on the Bulk list, and if HCD does not set BulkListFilled, then BulkListFilled will still be 0 when HC completes processing the Bulk list and Bulk list processing will stop.
1	R/W	R/W	0x0	<b>ControlListFilled</b> This bit is used to indicate whether there are any TDs on the Control list. It is set by HCD whenever it adds a TD to an ED in the Control list. When HC begins to process the head of the Control list, it checks CLF. As long as ControlListFilled is 0, HC will not start processing the Control list. If CF is 1, HC will start processing the Control list and will set ControlListFilled to 0. If HC finds a TD on the list, then HC will set ControlListFilled to 1

				causing the Control list processing to continue. If no TD is found on the Control list, and if the HCD does not set ControllistFilled, then ControllistFilled will still be 0 when HC completes processing the Control list and Control list processing will stop.
0	R/W	R/E	0x0	<p><b>HostControllerReset</b></p> <p>This bit is by HCD to initiate a software reset of HC. Regardless of the functional state of HC, it moves to the USBsuspend state in which most of the operational registers are reset except those stated otherwise; e.g, the InterruptRouting field of HcControl, and no Host bus accesses are allowed. This bit is cleared by HC upon the completion of the reset operation. The reset operation must be completed within 10 ms. This bit, when set, should not cause a reset to the Root Hub and no subsequent reset signaling should be asserted to its downstream ports.</p>

#### 8.5.2.6.4. HcInterruptStatus Register(Default Value: 0x00000000)

Offset: 0x40c				Register Name: <b>HcInterruptStatus</b>
Bit	Read/Write		Default/Hex	Description
	HCD	HC		
31:7	/	/	0x0	Reserved
6	R/W	R/W	0x0	<p><b>RootHubStatusChange</b></p> <p>This bit is set when the content of HcRhStatus or the content of any of HcRhPortStatus[NumberOfDownstreamPort] has changed.</p>
5	R/W	R/W	0x0	<p><b>FrameNumberOverflow</b></p> <p>This bit is set when the MSb of HcFmNumber (bit 15) changes value, from 0 to 1 or from 1 to 0, and after HccaFrameNumber has been updated.</p>
4	R/W	R/W	0x0	<p><b>UnrecoverableError</b></p> <p>This bit is set when HC detects a system error not related to USB. HC should not proceed with any processing nor signaling before the system error has been corrected. HCD clears this bit after HC has been reset.</p>
3	R/W	R/W	0x0	<p><b>ResumeDetected</b></p> <p>This bit is set when HC detects that a device on the USB is asserting resume signaling. It is the transition from no resume signaling to resume signaling causing this bit to be set. This bit is not set when HCD sets the USBRseume state.</p>
2	R/W	R/W	0x0	<p><b>StartofFrame</b></p> <p>This bit is set by HC at each start of frame and after the update of HccaFrameNumber. HC also generates a SOF token at the same time.</p>
1	R/W	R/W	0x0	<p><b>WritebackDoneHead</b></p> <p>This bit is set immediately after HC has written HcDoneHead to HccaDoneHead. Further updates of the HccaDoneHead will not occur until this bit has been cleared. HCD should only clear this bit after it has saved the content of HccaDoneHead.</p>
0	R/W	R/W	0x0	<b>SchedulingOverrun</b>

				This bit is set when the USB schedule for the current Frame overruns and after the update of HccaFrameNumber. A scheduling overrun will also cause the SchedulingOverrunCount of HcCommandStatus to be Incremented.
--	--	--	--	---

**8.5.2.6.5. HcInterruptEnable Register(Default Value: 0x00000000)**

Offset: 0x410				Register Name: <b>HcInterruptEnable Register</b>	
Bit	Read/Write		Default/Hex	Description	
	HCD	HC			
31	R/W	R	0x0	MasterInterruptEnable A '0' written to this field is ignored by HC. A '1' written to this field enables interrupt generation due to events specified in the other bits of this register. This is used by HCD as Master Interrupt Enable.	
30:7	/	/	0x0	Reserved	
6	R/W	R	0x0	RootHubStatusChange Interrupt Enable	
				0	Ignore;
				1	Enable interrupt generation due to Root Hub Status Change;
5	R/W	R	0x0	FrameNumberOverflow Interrupt Enable	
				0	Ignore;
				1	Enable interrupt generation due to Frame Number Over Flow;
4	R/W	R	0x0	UnrecoverableError Interrupt Enable	
				0	Ignore;
				1	Enable interrupt generation due to Unrecoverable Error;
3	R/W	R	0x0	ResumeDetected Interrupt Enable	
				0	Ignore;
				1	Enable interrupt generation due to Resume Detected;
2	R/W	R	0x0	StartofFrame Interrupt Enable	
				0	Ignore;
				1	Enable interrupt generation due to Start of Flame;
1	R/W	R	0x0	WritebackDoneHead Interrupt Enable	
				0	Ignore;
				1	Enable interrupt generation due to Write back Done Head;
0	R/W	R	0x0	SchedulingOverrun Interrupt Enable	
				0	Ignore;
				1	Enable interrupt generation due to Scheduling Overrun;

**8.5.2.6.6. HcInterruptDisable Register(Default Value: 0x00000000)**

Offset: 0x414	Register Name: <b>HcInterruptDisable Register</b>
---------------	---



Bit	Read/Write		Default/Hex	Description
	HCD	HC		
31	R/W	R	0x0	MasterInterruptEnable A written '0' to this field is ignored by HC. A '1' written to this field disables interrupt generation due events specified in the other bits of this register. This field is set after a hardware or software reset.
30:7	/	/	0x00	Reserved
6	R/W	R	0x0	RootHubStatusChange Interrupt Disable
				0   Ignore;
5	R/W	R	0x0	FrameNumberOverflow Interrupt Disable
				1   Disable interrupt generation due to Frame Number Over Flow;
4	R/W	R	0x0	UnrecoverableError Interrupt Disable
				1   Disable interrupt generation due to Unrecoverable Error;
3	R/W	R	0x0	ResumeDetected Interrupt Disable
				1   Disable interrupt generation due to Resume Detected;
2	R/W	R	0x0	StartofFrame Interrupt Disable
				1   Disable interrupt generation due to Start of Flame;
1	R/W	R	0x0	WritebackDoneHead Interrupt Disable
				1   Disable interrupt generation due to Write back Done Head;
0	R/w	R	0x0	SchedulingOverrun Interrupt Disable
				1   Disable interrupt generation due to Scheduling Overrun;

#### 8.5.2.6.7. HcHCCA Register(Default Value: 0x00000000)

Offset: 0x418				Register Name: <b>HcHCCA</b>
Bit	Read/Write		Default/Hex	Description
	HCD	HC		
31:8	R/W	R	0x0	HCCA[31:8] This is the base address of the Host Controller Communication Area. This area is used to hold the control structures and the Interrupt table that are accessed by both the Host Controller and the Host Controller Driver.
7:0	R	R	0x0	HCCA[7:0] The alignment restriction in HcHCCA register is evaluated by examining the number of zeros in the lower order bits. The minimum alignment is 256 bytes, therefore, bits 0 through 7 must always return 0 when read.

**8.5.2.6.8. HcPeriodCurrentED Register(Default Value: 0x00000000)**

Offset: 0x41c				Register Name: <b>HcPeriodCurrentED(PCED)</b>
Bit	Read/Write		Default/Hex	Description
	HCD	HC		
31:4	R	R/W	0x0	PCED[31:4] This is used by HC to point to the head of one of the Periodec list which will be processed in the current Frame. The content of this register is updated by HC after a periodic ED has been processed. HCD may read the content in determining which ED is currently being processed at the time of reading.
3:0	R	R	0x0	PCED[3:0] Because the general TD length is 16 bytes, the memory structure for the TD must be aligned to a 16-byte boundary. So the lower bits in the PCED, through bit 0 to bit 3 must be zero in this field.

**8.5.2.6.9. HcControlHeadED Register(Default Value: 0x00000000)**

Offset: 0x420				Register Name: <b>HcControlHeadED[CHED]</b>
Bit	Read/Write		Default/Hex	Description
	HCD	HC		
31:4	R/W	R	0x0	EHCD[31:4] The HcControlHeadED register contains the physical address of the first Endpoint Descriptor of the Control list. HC traverse the Control list starting with the HcControlHeadED pointer. The content is loaded from HCCA during the initialization of HC.
3:0	R	R	0x0	EHCD[3:0] Because the general TD length is 16 bytes, the memory structure for the TD must be aligned to a 16-byte boundary. So the lower bits in the PCED, through bit 0 to bit 3 must be zero in this field.

**8.5.2.6.10. HcControlCurrentED Register(Default Value: 0x00000000)**

Offset: 0x424				Register Name: <b>HcControlCurrentED[CCED]</b>
Bit	Read/Write		Default/Hex	Description
	HCD	HC		
31:4	R/W	R/W	0x0	CCED[31:4] The pointer is advanced to the next ED after serving the present one. HC will continue processing the list from where it left off in the last Frame. When it reaches the end of the Control list, HC checks the

				<p>ControlListFilled of in HcCommandStatus. If set, it copies the content of HcControlHeadED to HcControlCurrentED and clears the bit. If not set, it does nothing.</p> <p>HCD is allowed to modify this register only when the ControlListEnable of HcControl is cleared. When set, HCD only reads the instantaneous value of this register. Initially, this is set to zero to indicate the end of the Control list.</p>
3:0	R	R	0x0	<p>CCED[3:0]</p> <p>Because the general TD length is 16 bytes, the memory structure for the TD must be aligned to a 16-byte boundary. So the lower bits in the PCED, through bit 0 to bit 3 must be zero in this field.</p>

#### 8.5.2.6.11. HcBulkHeadED Register(Default Value: 0x00000000)

Offset: 0x428			Register Name: <b>HcBulkHeadED [BHED]</b>	
Bit	Read/Write		Default/Hex	Description
	HCD	HC		
31:4	R/W	R	0x0	<p>BHED[31:4]</p> <p>The HcBulkHeadED register contains the physical address of the first Endpoint Descriptor of the Bulk list. HC traverses the Bulk list starting with the HcBulkHeadED pointer. The content is loaded from HCCA during the initialization of HC.</p>
3:0	R	R	0x0	<p>BHED[3:0]</p> <p>Because the general TD length is 16 bytes, the memory structure for the TD must be aligned to a 16-byte boundary. So the lower bits in the PCED, through bit 0 to bit 3 must be zero in this field.</p>

#### 8.5.2.6.12. HcBulkCurrentED Register(Default Value: 0x00000000)

Offset: 0x42c			Register Name: <b>HcBulkCurrentED [BCED]</b>	
Bit	Read/Write		Default/Hex	Description
	HCD	HC		
31:4	R/W	R/W	0x0	<p>BulkCurrentED[31:4]</p> <p>This is advanced to the next ED after the HC has served the present one. HC continues processing the list from where it left off in the last Frame. When it reaches the end of the Bulk list, HC checks the ControlListFilled of HcControl. If set, it copies the content of HcBulkHeadED to HcBulkCurrentED and clears the bit. If it is not set, it does nothing. HCD is only allowed to modify this register when the BulkListEnable of HcControl is cleared. When set, the HCD only reads the instantaneous value of this register. This is initially set to zero to indicate the end of the Bulk list.</p>
3:0	R	R	0x0	<p>BulkCurrentED [3:0]</p>

				Because the general TD length is 16 bytes, the memory structure for the TD must be aligned to a 16-byte boundary. So the lower bits in the PCED, through bit 0 to bit 3 must be zero in this field.
--	--	--	--	---

**8.5.2.6.13. HcDoneHead Register(Default Value: 0x00000000)**

Offset: 0x430				Register Name: <b>HcDoneHead</b>
Bit	Read/Write		Default/Hex	Description
	HCD	HC		
31:4	R	R/W	0x0	HcDoneHead[31:4] When a TD is completed, HC writes the content of HcDoneHead to the NextTD field of the TD. HC then overwrites the content of HcDoneHead with the address of this TD. This is set to zero whenever HC writes the content of this register to HCCA. It also sets the WritebackDoneHead of HcInterruptStatus.
3:0	R	R	0x0	HcDoneHead[3:0] Because the general TD length is 16 bytes, the memory structure for the TD must be aligned to a 16-byte boundary. So the lower bits in the PCED, through bit 0 to bit 3 must be zero in this field.

**8.5.2.6.14. HcFmInterval Register(Default Value: 0x00002EDF)**

Offset: 0x434				Register Name: <b>HcFmInterval Register</b>
Bit	Read/Write		Default/Hex	Description
	HCD	HC		
31	R/W	R	0x0	FrameIntervalToggler HCD toggles this bit whenever it loads a new value to FrameInterval.
30:16	R/W	R	0x0	FLargestDataPacket This field specifies a value which is loaded into the Largest Data Packet Counter at the beginning of each frame. The counter value represents the largest amount of data in bits which can be sent or received by the HC in a single transaction at any given time without causing scheduling overrun. The field value is calculated by the HCD.
15:14	/	/	0x0	Reserved
13:0	R/W	R	0x2edf	FrameInterval This specifies the interval between two consecutive SOFs in bit times. The nominal value is set to be 11,999. HCD should store the current value of this field before resetting HC. By setting the HostControllerReset field of HcCommandStatus as this will cause the HC to reset this field to its nominal value. HCD may choose to restore the stored value upon the completion of the Reset sequence.

**8.5.2.6.15. HcFmRemaining Register(Default Value: 0x00000000)**

Offset: 0x438				Register Name: <b>HcFmRemaining</b>
Bit	Read/Write		Default/Hex	Description
	HCD	HC		
31	R	R/W	0x0	FrameRemaining Toggle This bit is loaded from the FrameIntervalToggle field of HcFmInterval whenever FrameRemaining reaches 0. This bit is used by HCD for the synchronization between FrameInterval and FrameRemaining.
30:14	/	/	0x0	Reserved
13:0	R	RW	0x0	FramRemaining This counter is decremented at each bit time. When it reaches zero, it is reset by loading the FrameInterval value specified in HcFmInterval at the next bit time boundary. When entering the USBOPERATIONAL state, HC re-loads the content with the FrameInterval of HcFmInterval and uses the updated value from the next SOF.

**8.5.2.6.16. HcFmNumber Register(Default Value: 0x00000000)**

Offset: 0x43c				Register Name: <b>HcFmNumber</b>
Bit	Read/Write		Default/Hex	Description
	HCD	HC		
31:16				Reserved
15:0	R	R/W	0x0	FrameNumber This is incremented when HcFmRemaining is re-loaded. It will be rolled over to 0x0 after 0x0ffff. When entering the USBOPERATIONAL state, this will be incremented automatically. The content will be written to HCCA after HC has incremented the FrameNumber at each frame boundary and sent a SOF but before HC reads the first ED in that Frame. After writing to HCCA, HC will set the StartofFrame in HcInterruptStatus.

**8.5.2.6.17. HcPeriodicStart Register(Default Value: 0x00000000)**

Offset: 0x440				Register Name: <b>HcPeriodicStatus</b>
Bit	Read/Write		Default/Hex	Description
	HCD	HC		
31:14				Reserved
13:0	R/W	R	0x0	PeriodicStart After a hardware reset, this field is cleared. This is then set by HCD during the HC initialization. The value is calculated roughly as 10% off from HcFmInterval. A typical value will be 0x2A3F (0x3e67). When

				HcFmRemaining reaches the value specified, processing of the periodic lists will have priority over Control/Bulk processing. HC will therefore start processing the Interrupt list after completing the current Control or Bulk transaction that is in progress.
--	--	--	--	--

**8.5.2.6.18. HcLSThreshold Register(Default Value: 0x00000628)**

Offset: 0x444				Register Name: <b>HcLSThreshold</b>
Bit	Read/Write		Default/Hex	Description
	HCD	HC		
31:12				Reserved
11:0	R/W	R	0x0628	LSThreshold This field contains a value which is compared to the FrameRemaining field prior to initiating a Low Speed transaction. The transaction is started only if FrameRemaining <sup>3</sup> this field. The value is calculated by HCD with the consideration of transmission and setup overhead.

**8.5.2.6.19. HcRhDescriptorA Register(Default Value: 0x02001201)**

Offset: 0x448				Register Name: <b>HcRhDescriptorA</b>
Bit	Read/Write		Default/Hex	Description
	HCD	HC		
31:24	R/W	R	0x2	PowerOnToPowerGoodTime[POTPGT] This byte specifies the duration HCD has to wait before accessing a powered-on port of the Root Hub. It is implementation-specific. The unit of time is 2 ms. The duration is calculated as POTPGT * 2ms.
23:13				Reserved
12	R/W	R	1	NoOverCurrentProtection This bit describes how the overcurrent status for the Root Hub ports are reported. When this bit is cleared, the OverCurrentProtectionMode field specifies global or per-port reporting.
				0   Over-current status is reported collectively for all downstream ports.
11	R/W	R	0	OverCurrentProtectionMode This bit describes how the overcurrent status for the Root Hub ports are reported. At reset, these fields should reflect the same mode as PowerSwitchingMode. This field is valid only if the NoOverCurrentProtection field is cleared.
				0   Over-current status is reported collectively for all downstream ports.
				1   Over-current status is reported on per-port basis.

10	R	R	0x0	<b>Device Type</b> This bit specifies that the Root Hub is not a compound device. The Root Hub is not permitted to be a compound device. This field should always read/write 0.				
9	R/W	R	1	<b>PowerSwitchingMode</b> This bit is used to specify how the power switching of the Root Hub ports is controlled. It is implementation-specific. This field is only valid if the NoPowerSwitching field is cleared. <table border="1" style="margin-left: 20px;"> <tr> <td>0</td> <td>All ports are powered at the same time.</td> </tr> <tr> <td>1</td> <td>Each port is powered individually. This mode allows port power to be controlled by either the global switch or per-port switching. If the PortPowerControlMask bit is set, the port responds only to port power commands (Set/ClearPortPower). If the port mask is cleared, then the port is controlled only by the global power switch (Set/ClearGlobalPower).</td> </tr> </table>	0	All ports are powered at the same time.	1	Each port is powered individually. This mode allows port power to be controlled by either the global switch or per-port switching. If the PortPowerControlMask bit is set, the port responds only to port power commands (Set/ClearPortPower). If the port mask is cleared, then the port is controlled only by the global power switch (Set/ClearGlobalPower).
0	All ports are powered at the same time.							
1	Each port is powered individually. This mode allows port power to be controlled by either the global switch or per-port switching. If the PortPowerControlMask bit is set, the port responds only to port power commands (Set/ClearPortPower). If the port mask is cleared, then the port is controlled only by the global power switch (Set/ClearGlobalPower).							
8	R/W	R	0	<b>NoPowerSwitching</b> These bits are used to specify whether power switching is supported or ports are always powered. It is implementation-specific. When this bit is cleared, the PowerSwitchingMode specifies global or per-port switching. <table border="1" style="margin-left: 20px;"> <tr> <td>0</td> <td>Ports are power switched.</td> </tr> <tr> <td>1</td> <td>Ports are always powered on when the HC is powered on.</td> </tr> </table>	0	Ports are power switched.	1	Ports are always powered on when the HC is powered on.
0	Ports are power switched.							
1	Ports are always powered on when the HC is powered on.							
7:0	R	R	0x01	<b>NumberDownstreamPorts</b> These bits specify the number of downstream ports supported by the Root Hub. It is implementation-specific. The minimum number of ports is 1. The maximum number of ports supported.				

**8.5.2.6.20. HcRhDescriptorB Register(Default Value: 0x00000000)**

Offset: 0x44c			Register Name: <b>HcRhDescriptorB Register</b>							
Bit	Read/Write		Default/Hex	Description						
	HCD	HC								
31:16	R/W	R	0x0	<b>PortPowerControlMask</b> Each bit indicates if a port is affected by a global power control command when PowerSwitchingMode is set. When set, the port's power state is only affected by per-port power control (Set/ClearPortPower). When cleared, the port is controlled by the global power switch (Set/ClearGlobalPower). If the device is configured to global switching mode (PowerSwitchingMode = 0 ), this field is not valid. <table border="1" style="margin-left: 20px;"> <tr> <td>Bit0</td> <td>Reserved</td> </tr> <tr> <td>Bit1</td> <td>Ganged-power mask on Port #1.</td> </tr> <tr> <td>Bit2</td> <td>Ganged-power mask on Port #2.</td> </tr> </table>	Bit0	Reserved	Bit1	Ganged-power mask on Port #1.	Bit2	Ganged-power mask on Port #2.
Bit0	Reserved									
Bit1	Ganged-power mask on Port #1.									
Bit2	Ganged-power mask on Port #2.									

				...											
				Bit15	Ganged-power mask on Port #15.										
15:0	R/W	R	0x0	<p>DeviceRemovable</p> <p>Each bit is dedicated to a port of the Root Hub. When cleared, the attached device is removable. When set, the attached device is not removable.</p> <table border="1"> <tr> <td>Bit0</td> <td>Reserved</td> </tr> <tr> <td>Bit1</td> <td>Device attached to Port #1.</td> </tr> <tr> <td>Bit2</td> <td>Device attached to Port #2.</td> </tr> <tr> <td>...</td> <td></td> </tr> <tr> <td>Bit15</td> <td>Device attached to Port #15.</td> </tr> </table>		Bit0	Reserved	Bit1	Device attached to Port #1.	Bit2	Device attached to Port #2.	...		Bit15	Device attached to Port #15.
Bit0	Reserved														
Bit1	Device attached to Port #1.														
Bit2	Device attached to Port #2.														
...															
Bit15	Device attached to Port #15.														

**8.5.2.6.21. HcRhStatus Register(Default Value: 0x00000000)**

Offset: 0x450				Register Name: <b>HcRhStatus Register</b>				
Bit	Read/Write		Default/Hex	Description				
	HCD	HC						
31	W	R	0	(write)ClearRemoteWakeupEnable Write a '1' clears DeviceRemoteWakeupEnable. Write a '0' has no effect.				
30:18	/	/	0x0	Reserved				
17	R/W	R	0	OverCurrentIndicatorChang This bit is set by hardware when a change has occurred to the OverCurrentIndicator field of this register. The HCD clears this bit by writing a '1'.Writing a '0' has no effect.				
16	R/W	R	0x0	(read)LocalPowerStartusChange The Root Hub does not support the local power status features, thus, this bit is always read as '0'. (write)SetGlobalPower In global power mode (PowerSwitchingMode=0), This bit is written to '1' to turn on power to all ports (clear PortPowerStatus). In per-port power mode, it sets PortPowerStatus only on ports whose PortPowerControlMask bit is not set. Writing a '0' has no effect.				
15	R/W	R	0x0	(read)DeviceRemoteWakeupEnable This bit enables a ConnectStatusChange bit as a resume event, causing a USBSUSPEND to USBRESUME state transition and setting the ResumeDetected interrupt. <table border="1"> <tr> <td>0</td> <td>ConnectStatusChange is not a remote wakeup event.</td> </tr> <tr> <td>1</td> <td>ConnectStatusChange is a remote wakeup event.</td> </tr> </table> (write)SetRemoteWakeupEnable Writing a '1' sets DeviceRemoveWakeupEnable. Writing a '0' has no effect.	0	ConnectStatusChange is not a remote wakeup event.	1	ConnectStatusChange is a remote wakeup event.
0	ConnectStatusChange is not a remote wakeup event.							
1	ConnectStatusChange is a remote wakeup event.							



14:2				Reserved
1	R	R/W	0x0	<p>OverCurrentIndicator</p> <p>This bit reports overcurrent conditions when the global reporting is implemented. When set, an overcurrent condition exists. When cleared, all power operations are normal.</p> <p>If per-port overcurrent protection is implemented this bit is always '0'</p>
0	R/W	R	0x0	<p>(Read)LocalPowerStatus</p> <p>When read, this bit returns the LocalPowerStatus of the Root Hub. The Root Hub does not support the local power status feature; thus, this bit is always read as '0'.</p> <p>(Write)ClearGlobalPower</p> <p>When write, this bit is operated as the ClearGlobalPower. In global power mode (PowerSwitchingMode=0), This bit is written to '1' to turn off power to all ports (clear PortPowerStatus). In per-port power mode, it clears PortPowerStatus only on ports whose PortPowerControlMask bit is not set. Writing a '0' has no effect.</p>

**8.5.2.6.22. HcRhPortStatus Register(Default Value: 0x00000100)**

Offset: 0x454				Register Name: <b>HcRhPortStatus</b>
Bit	Read/Write		Default/Hex	Description
	HCD	HC		
31:21	/	/	0x0	Reserved
20	R/W	R/W	0x0	<p>PortResetStatusChange</p> <p>This bit is set at the end of the 10-ms port reset signal. The HCD writes a '1' to clear this bit. Writing a '0' has no effect.</p>
				<table border="1"> <tr> <td>0</td> <td>port reset is not complete</td> </tr> <tr> <td>1</td> <td>port reset is complete</td> </tr> </table>
0	port reset is not complete			
1	port reset is complete			
19	R/W	R/W	0x0	<p>PortOverCurrentIndicatorChange</p> <p>This bit is valid only if overcurrent conditions are reported on a per-port basis. This bit is set when Root Hub changes the PortOverCurrentIndicator bit. The HCD writes a '1' to clear this bit. Writing a '0' has no effect.</p>
				<table border="1"> <tr> <td>0</td> <td>no change in PortOverCurrentIndicator</td> </tr> <tr> <td>1</td> <td>PortOverCurrentIndicator has changed</td> </tr> </table>
0	no change in PortOverCurrentIndicator			
1	PortOverCurrentIndicator has changed			
18	R/W	R/W	0x0	<p>PortSuspendStatusChange</p> <p>This bit is set when the full resume sequence has been completed. This sequence includes the 20-s resume pulse, LS EOP, and 3-ms resynchronization delay. The HCD writes a '1' to clear this bit. Writing a '0' has no effect. This bit is also cleared when ResetStatusChange is set.</p>
				<table border="1"> <tr> <td>0</td> <td>resume is not completed</td> </tr> <tr> <td>1</td> <td>resume completed</td> </tr> </table>
0	resume is not completed			
1	resume completed			
17	R/W	R/W	0x0	PortEnableStatusChange

				<p>This bit is set when hardware events cause the PortEnableStatus bit to be cleared. Changes from HCD writes do not set this bit. The HCD writes a '1' to clear this bit. Writing a '0' has no effect.</p> <table border="1"> <tr> <td>0</td> <td>no change in PortEnableStatus</td> </tr> <tr> <td>1</td> <td>change in PortEnableStatus</td> </tr> </table>	0	no change in PortEnableStatus	1	change in PortEnableStatus
0	no change in PortEnableStatus							
1	change in PortEnableStatus							
16	R/W	R/W	0x0	<p><b>ConnectStatusChange</b> This bit is set whenever a connect or disconnect event occurs. The HCD writes a '1' to clear this bit. Writing a '0' has no effect. If CurrentConnectStatus is cleared when a SetPortReset, SetPortEnable, or SetPortSuspend write occurs, this bit is set to force the driver to re-evaluate the connection status since these writes should not occur if the port is disconnected.</p> <table border="1"> <tr> <td>0</td> <td>no change in PortEnableStatus</td> </tr> <tr> <td>1</td> <td>change in PortEnableStatus</td> </tr> </table> <p>Note: If the DeviceRemovable[NDP] bit is set, this bit is set only after a Root Hub reset to inform the system that the device is attached.</p>	0	no change in PortEnableStatus	1	change in PortEnableStatus
0	no change in PortEnableStatus							
1	change in PortEnableStatus							
15:10	/	/	0x0	Reserved				
				<p><b>(read)LowSpeedDeviceAttached</b> This bit indicates the speed of the device attached to this port. When set, a Low Speed device is attached to this port. When clear, a Full Speed device is attached to this port. This field is valid only when the CurrentConnectStatus is set.</p> <table border="1"> <tr> <td>0</td> <td>full speed device attached</td> </tr> <tr> <td>1</td> <td>low speed device attached</td> </tr> </table>	0	full speed device attached	1	low speed device attached
0	full speed device attached							
1	low speed device attached							
9	R/W	R/W	-	<p><b>(write)ClearPortPower</b> The HCD clears the PortPowerStatus bit by writing a '1' to this bit. Writing a '0' has no effect.</p>				
8	R/W	R/W	0x1	<p><b>(read)PortPowerStatus</b> This bit reflects the port's power status, regardless of the type of power switching implemented. This bit is cleared if an overcurrent condition is detected. HCD sets this bit by writing SetPortPower or SetGlobalPower. HCD clears this bit by writing ClearPortPower or ClearGlobalPower. Which power control switches are enabled is determined by PowerSwitchingMode and PortPortControlMask[NumberDownstreamPort]. In global switching mode(PowerSwitchingMode=0), only Set/ClearGlobalPower controls this bit. In per-port power switching (PowerSwitchingMode=1), if the PortPowerControlMask[NDP] bit for the port is set, only Set/ClearPortPower commands are enabled. If the mask is not set, only Set/ClearGlobalPower commands are enabled. When port power is disabled, CurrentConnectStatus, PortEnableStatus, PortSuspendStatus, and PortResetStatus should be reset.</p>				

				<table border="1"> <tr> <td>0</td> <td>port power is off</td> </tr> <tr> <td>1</td> <td>port power is on</td> </tr> </table> <p>(write)SetPortPower The HCD writes a '1' to set the PortPowerStatus bit. Writing a '0' has no effect.</p> <p>Note: This bit is always reads '1b' if power switching is not supported.</p>	0	port power is off	1	port power is on
0	port power is off							
1	port power is on							
7:5	/	/	0x0	Reserved				
4	R/W	R/W	0x0	<p>(read)PortResetStatus When this bit is set by a write to SetPortReset, port reset signaling is asserted. When reset is completed, this bit is cleared when PortResetStatusChange is set. This bit cannot be set if CurrentConnectStatus is cleared.</p> <table border="1"> <tr> <td>0</td> <td>port reset signal is not active</td> </tr> <tr> <td>1</td> <td>port reset signal is active</td> </tr> </table> <p>(write)SetPortReset The HCD sets the port reset signaling by writing a '1' to this bit. Writing a '0' has no effect. If CurrentConnectStatus is cleared, this write does not set PortResetStatus, but instead sets ConnectStatusChange. This informs the driver that it attempted to reset a disconnected port.</p>	0	port reset signal is not active	1	port reset signal is active
0	port reset signal is not active							
1	port reset signal is active							
3	R/W	R/W	0x0	<p>(read)PortOverCurrentIndicator This bit is only valid when the Root Hub is configured in such a way that overcurrent conditions are reported on a per-port basis. If per-port overcurrent reporting is not supported, this bit is set to 0. If cleared, all power operations are normal for this port. If set, an overcurrent condition exists on this port. This bit always reflects the overcurrent input signal.</p> <table border="1"> <tr> <td>0</td> <td>no overcurrent condition.</td> </tr> <tr> <td>1</td> <td>overcurrent condition detected.</td> </tr> </table> <p>(write)ClearSuspendStatus The HCD writes a '1' to initiate a resume. Writing a '0' has no effect. A resume is initiated only if PortSuspendStatus is set.</p>	0	no overcurrent condition.	1	overcurrent condition detected.
0	no overcurrent condition.							
1	overcurrent condition detected.							
2	R/W	R/W	0x0	<p>(read)PortSuspendStatus This bit indicates the port is suspended or in the resume sequence. It is set by a SetSuspendState write and cleared when PortSuspendStatusChange is set at the end of the resume interval. This bit cannot be set if CurrentConnectStatus is cleared. This bit is also cleared when PortResetStatusChange is set at the end of the port reset or when the HC is placed in the USBRESUME state. If an upstream resume is in progress, it should propagate to the HC.</p> <table border="1"> <tr> <td>0</td> <td>port is not suspended</td> </tr> <tr> <td>1</td> <td>port is suspended</td> </tr> </table>	0	port is not suspended	1	port is suspended
0	port is not suspended							
1	port is suspended							

				<p>(write)SetPortSuspend</p> <p>The HCD sets the PortSuspendStatus bit by writing a '1' to this bit. Writing a '0' has no effect. If CurrentConnectStatus is cleared, this write does not set PortSuspendStatus; instead it sets ConnectStatusChange. This informs the driver that it attempted to suspend a disconnected port.</p>				
1	R/W	R/W	0x0	<p>(read)PortEnableStatus</p> <p>This bit indicates whether the port is enabled or disabled. The Root Hub may clear this bit when an overcurrent condition, disconnect event, switched-off power, or operational bus error such as babble is detected. This change also causes PortEnabledStatusChange to be set. HCD sets this bit by writing SetPortEnable and clears it by writing ClearPortEnable. This bit cannot be set when CurrentConnectStatus is cleared. This bit is also set, if not already, at the completion of a port reset when ResetStatusChange is set or port suspend when SuspendStatusChange is set.</p> <table border="1"> <tr> <td>0</td> <td>port is disabled</td> </tr> <tr> <td>1</td> <td>port is enabled</td> </tr> </table> <p>(write)SetPortEnable</p> <p>The HCD sets PortEnableStatus by writing a '1'. Writing a '0' has no effect. If CurrentConnectStatus is cleared, this write does not set PortEnableStatus, but instead sets ConnectStatusChange. This informs the driver that it attempted to enable a disconnected Port.</p>	0	port is disabled	1	port is enabled
0	port is disabled							
1	port is enabled							
0	R/W	R/W	0x0	<p>(read)CurrentConnectStatus</p> <p>This bit reflects the current state of the downstream port.</p> <table border="1"> <tr> <td>0</td> <td>No device connected</td> </tr> <tr> <td>1</td> <td>Device connected</td> </tr> </table> <p>(write)ClearPortEnable</p> <p>The HCD writes a '1' to clear the PortEnableStatus bit. Writing '0' has no effect. The CurrentConnectStatus is not affected by any write.</p> <p>Note: This bit is always read '1' when the attached device is nonremovable(DviceRemoveable[NumberDownstreamPort]).</p>	0	No device connected	1	Device connected
0	No device connected							
1	Device connected							

**8.5.2.7. HCI Interface Control and Status Register Description**

**8.5.2.7.1. HCI Interface Control Register(Default Value: 0x00000000)**

Offset: 0x800			Register Name: <b>HCI_ICR</b>
Bit	R/W	Default/Hex	Description
31:21	/	/	Reserved.
20	R/W	0	EHCI HS force Set 1 to this field force the ehci enter the high speed mode during bus reset. This field only valid when the bit 1 is set.

19:18	/	/	/
17	R/W	0	HSIC Connect detect 1 in this field enable the hsic phy to detect device connect pulse on the bus. This field only valid when the bit 1 is set.
16	R/W	0	HSIC Connect Interrupt Enable Enable the HSIC connect interrupt. This field only valid when the bit 1 is set.
15:13	/	/	/
12	/	/	/
11	R/W	0	AHB Master interface INCR16 enable 1: Use INCR16 when appropriate 0: do not use INCR16,use other enabled INCRX or unspecified length burst INCR
10	R/W	0	AHB Master interface INCR8 enable 1: Use INCR8 when appropriate 0: do not use INCR8,use other enabled INCRX or unspecified length burst INCR
9	R/W	0	AHB Master interface burst type INCR4 enable 1: Use INCR4 when appropriate 0: do not use INCR4,use other enabled INCRX or unspecified length burst INCR
8	R/W	0	AHB Master interface INCRX align enable 1: start INCRx burst only on burst x-align address 0: Start burst on any double word boundary Note: This bit must enable if any bit of 11:9 is enabled
7:2	/	/	Reserved
1	R/W	0	HSIC 0:/ 1:HSIC This meaning is only valid when the controller is HCI1.
0	R/W	0	ULPI bypass enable。 1: Enable UTMI interface, disable ULPI interface(SP used utmi interface) 0: Enable ULPI interface, disable UTMI interface

#### 8.5.2.7.2. HSIC status Register(Default Value: 0x00000000)

Offset: 0x804			Register Name: <b>HSIC_STATUS</b>
Bit	R/W	Default/Hex	Description
31:17	/	/	/
16	R/W	0	HSIC Connect Status 1 in this field indicates a device connect pulse being detected on the bus. This field only valid when the EHCI HS force bit and the HSIC Phy Select bit is set.

			When the HSIC Connect Interrupt Enable is set, 1 in this bit will generate an interrupt to the system. This register is valid on HCI1.
15:0	/	/	/

#### 8.5.2.8. USB Host Clock Requirement

Name	Description
HCLK	System clock (provided by AHB bus clock). This clock needs to be >30MHz.
CLK60M	Clock from PHY for HS SIE, is constant to be 60MHz.
CLK48M	Clock from PLL for FS/LS SIE, is constant to be 48MHz.

Confidential

## 8.6. I2S/PCM

### 8.6.1. Overview

The I2S/PCM Controller has been designed to transfer streaming audio-data between the system memory and the codec chip. The controller supports standard I2S format, Left-justified Mode format, Right-justified Mode format, PCM Mode format and TDM Mode format.

The I2S/PCM controller includes the following features:

- Supports industry-standard AMBA Peripheral Bus (APB) and it is fully compliant with the AMBA Specification, Revision 2.0
- Support different sample period width in each interface when using LRCK and LRCKR at the same time
- Support full-duplex synchronous work mode
- Support Master / Slave mode
- Support adjustable interface voltage
- Support clock up to 100MHz
- Support adjustable audio sample rate from 8-bit to 32-bit.
- Support up to 8 slots which has adjustable width from 8-bit to 32-bit.
- Support sample rate from 8KHz to 192KHz
- Support 8-bits u-law and 8-bits A-law companded sample
- One 128 x 32-bit width FIFO for data transmit, one 64 x 32-bit width FIFO for data receive
- Support programmable PCM frame width: 1 BCLK width (short frame) and 2 BCLKs width (long frame)
- Programmable FIFO thresholds
- Interrupt and DMA Support
- Support loopback mode for test

### 8.6.2. Signal Description

#### 8.6.2.1. I2S/PCM Pin List

Signal Name(x=0,1)	Direction(M)	Description
PCMx_CLK	O	I2S/PCM x MCLK Output
PCMx_SYNC	I/O	I2S/PCM x Sample Rate Clock/Sync
PCMx_DIN	I	I2S/PCM x Serial Data Input
PCMx_DOUT	O	I2S/PCM x Serial Data Output

#### 8.6.2.2. Digital Audio Interface Clock Source and Frequency

	Description

Audio_PLL	24.576Mhz or 22.5792Mhz generated by AUDIO-PLL to produce 48KHz or 44.1KHz serial frequency
-----------	---

### 8.6.3. Functionalities Description

#### 8.6.3.1. Typical Applications

The I2S/PCM provides a serial bus interface for stereo and multichannel audio data. This interface is most commonly used by consumer audio market, including compact disc, digital audio tape, digital sound processors, and digital TV-sound.

#### 8.6.3.2. Functional Block Diagram

The I2S/PCM Interface block diagram is shown below:

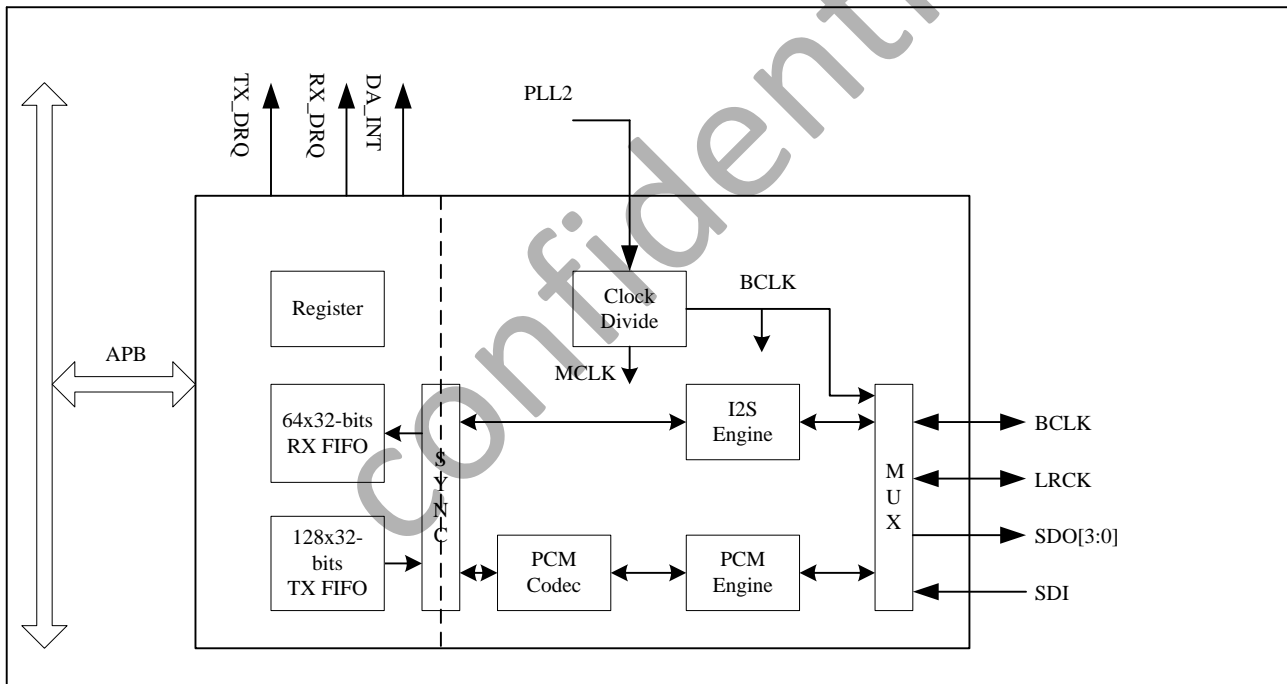

Figure 8-8. I2S/PCM Interface System Block Diagram

### 8.6.4. Timing Diagram



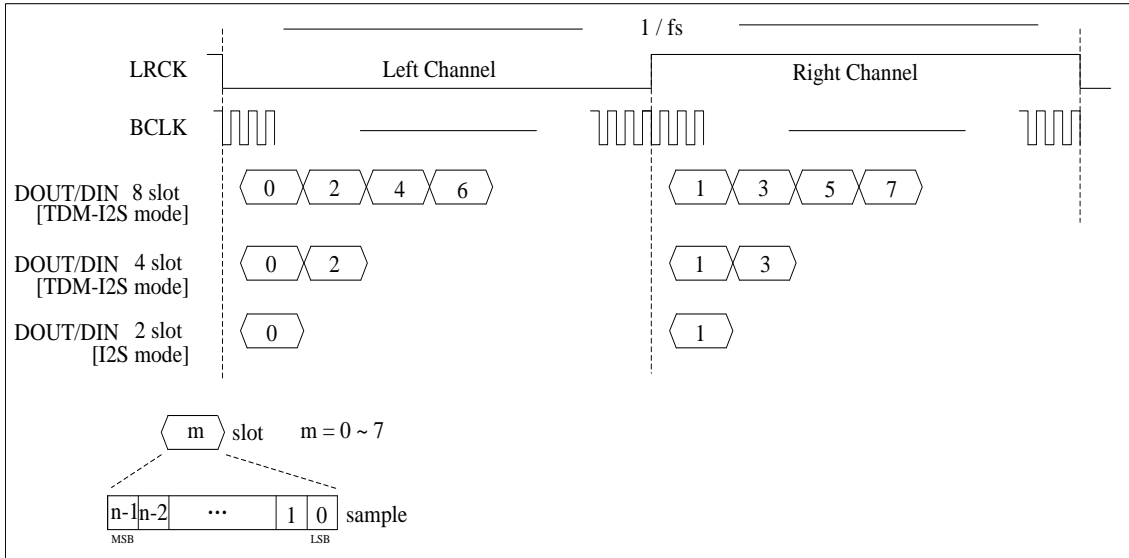

Figure 8-9. Timing Diagram for I2S/TDM-I2S mode

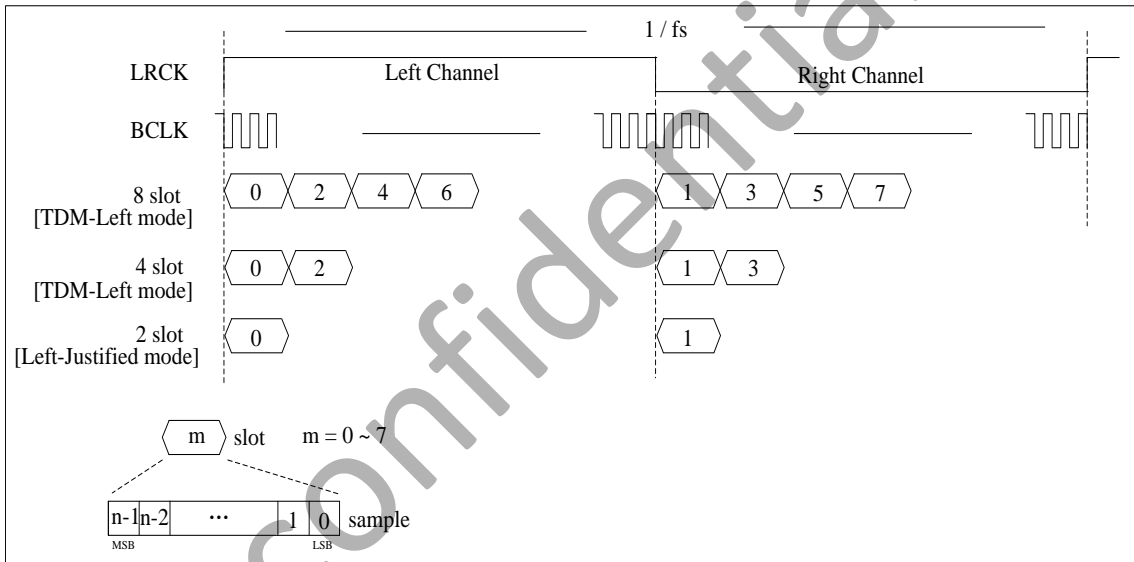

Figure 8-10. Timing Diagram for Left-justified/TDM-Left mode

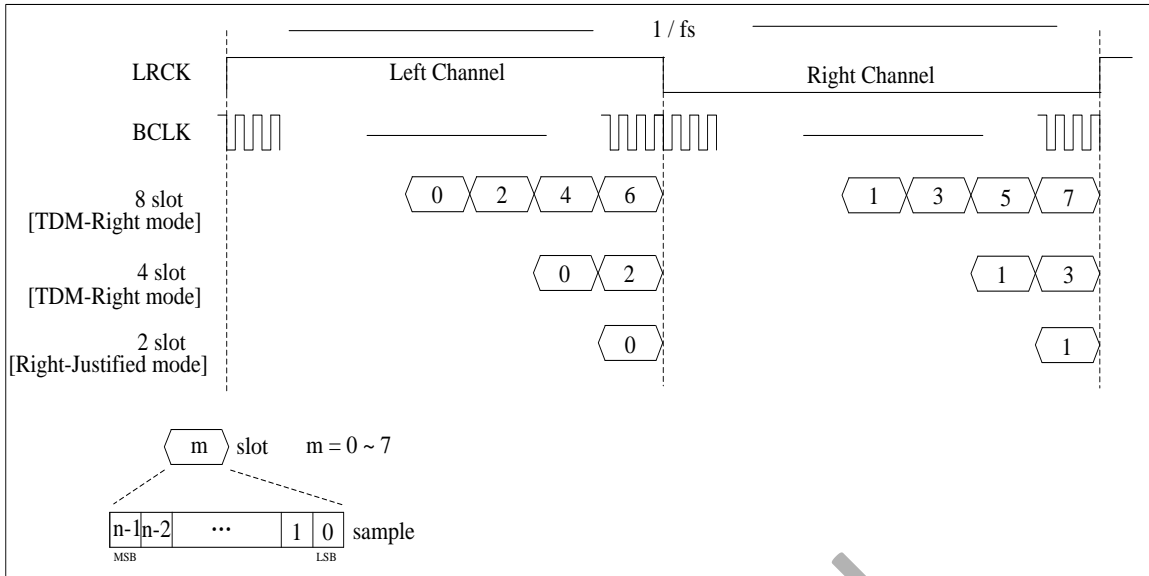

Figure 8-11. Timing Diagram for Right-justified/TDM-Right mode

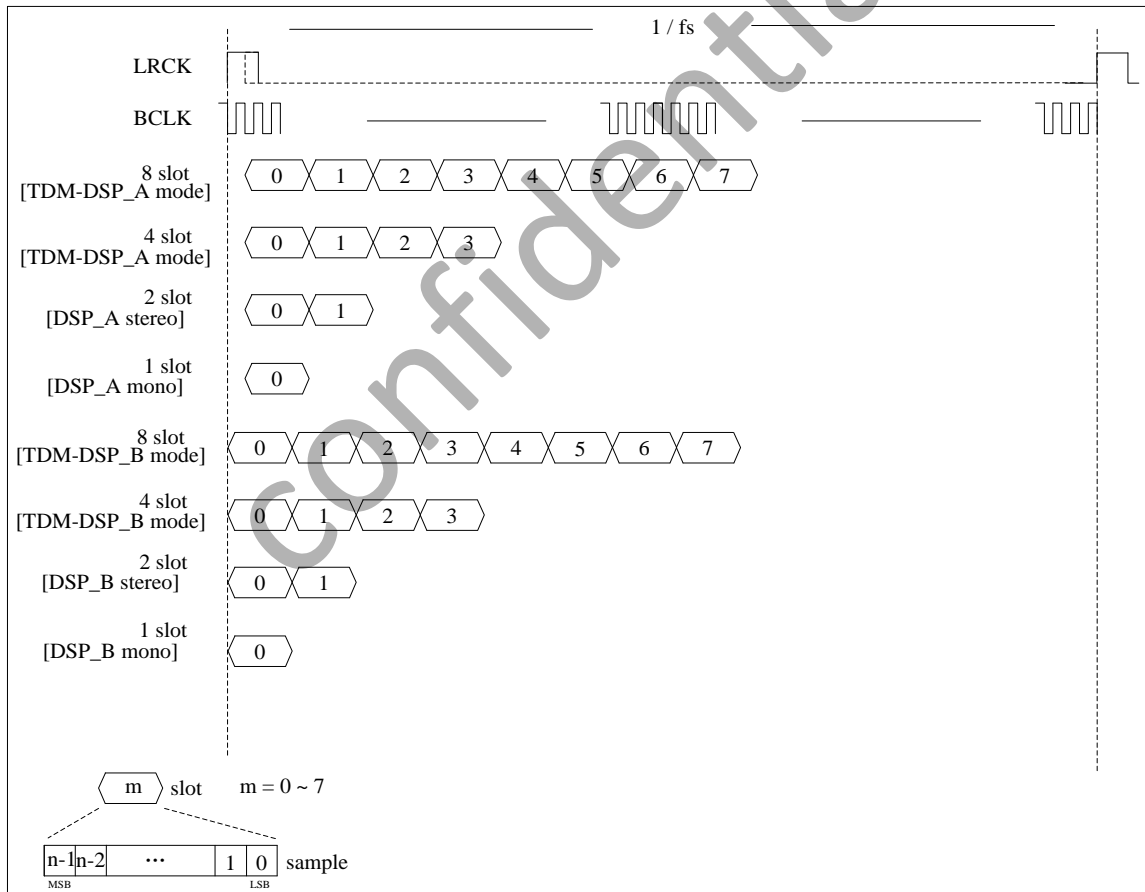

Figure 8-12. Timing Diagram for PCM/TDM-PCM mode

### 8.6.5. Operation Modes

The software operation of the I2S/PCM is divided into five steps: system setup, PCM/I2S initialization, the channel setup, DMA setup and Enable/Disable module. These five steps are described in detail in the following sections.

#### 8.6.5.1. System setup and I2S/PCM initialization

The first step in the system setup is properly programming the GPIO. Because the I2S/PCM port is a multiplex pin. You can find the function in the pin multiplex specification. The clock source for the I2S/PCM should be followed. At first you must reset the audio PLL through the PLL\_ENABLE bit of PLL\_AUDIO\_CTRL\_REG in the CCMU. The second step, you must setup the frequency of the audio pll in the PLL\_AUDIO\_CTRL\_REG. The configuration of audio pll can be found in the chapter 1.3.2. After that, you must open the I2S/PCM gating through the DAUDIO0\_CLK\_REG/DAUDIO1\_CLK\_REG when you checkout that the LOCK bit of PLL\_AUDIO\_CTRL\_REG become 1. At last, you must reset the I2S/PCM in BUS\_RST\_REG3's bit[13:12] and open the I2S/PCM bus gating in the BUS\_GATING\_REG2's bit[13:12].

After the system setup, the register of I2S/PCM can be setup. At first, you should initialization the I2S/PCM. You should closed the globe enable bit(DA\_CTL[0]), TX enable bit(DA\_CTL[2]) and RX enable bit(DA\_CTL[1]) by write 0 to it. After that, you must clear the TX/RX FIFO by write 0 to register DA\_FCTL[25:24]. At last, you can clear the TX/RX FIFO counter by write 0 to DA\_TXCNT/DA\_RXCNT.

#### 8.6.5.2. The channel setup and DMA setup

Before the usage and control of I2S/PCM, you must configure the I2C. The configuration of I2C will not describe in this chapter. But you can only configure I2S/PCM of master and slave through the I2C. In the following, you can setup the I2S/PCM of mater and slave. The configuration can be referred to the the protocol of I2S/PCM. Then, you can set the translation mode, the sample precision, the wide of slot, the frame mode and the trigger level. The register set can be found in the spec.

The I2S/PCM supports three methods to transfer the data. The most common way is DMA, the set of DMA can be found in the DMA spec. In this module, you just to enable the DRQ.

#### 8.6.5.3. Enable and disable the I2S/PCM

To enable the function, you can enable TX/RX by write the DA\_CTL[2:1]. After that, you must enable I2S/PCM by write the Globe Enable bit to 1 in the DA\_CTL. The disable process is writed the Globe Enable to 0.

### 8.6.6. I2S/PCM Register List

Module Name	Base Address
I2S/PCM 0	0x01C22000
I2S/PCM 1	0x01C22400
I2S/PCM 2	0x01C22800 (for HDMI)

Register Name	Offset	Description
I2S/PCM_CTL	0x00	I2S/PCM Control Register
I2S/PCM_FMT0	0x04	I2S/PCM Format Register 0
I2S/PCM_FMT1	0x08	I2S/PCM Format Register 1
I2S/PCM_ISTA	0x0C	I2S/PCM Interrupt Status Register
I2S/PCM_RXFIFO	0x10	I2S/PCM RX FIFO Register
I2S/PCM_FCTL	0x14	I2S/PCM FIFO Control Register
I2S/PCM_FSTA	0x18	I2S/PCM FIFO Status Register
I2S/PCM_INT	0x1C	I2S/PCM DMA & Interrupt Control Register
I2S/PCM_TXFIFO	0x20	I2S/PCM TX FIFO Register
I2S/PCM_CLKD	0x24	I2S/PCM Clock Divide Register
I2S/PCM_TXCNT	0x28	I2S/PCM TX Sample Counter Register
I2S/PCM_RXCNT	0x2C	I2S/PCM RX Sample Counter Register
I2S/PCM_CHCFG	0x30	I2S/PCM Channel Configuration register
I2S/PCM_TX0CHCFG	0x34	I2S/PCM TX0 Channel Configuration register
I2S/PCM_TX1CHSEL	0x38	I2S/PCM TX1 Channel Select Register
I2S/PCM_TX2CHSEL	0x3C	I2S/PCM TX2 Channel Select Register
I2S/PCM_TX3CHSEL	0x40	I2S/PCM TX3 Channel Select Register
I2S/PCM_TX0CHMAP	0x44	I2S/PCM TX0 Channel Mapping Register
I2S/PCM_TX1CHMAP	0x48	I2S/PCM TX1 Channel Mapping Register
I2S/PCM_TX2CHMAP	0x4C	I2S/PCM TX2 Channel Mapping Register
I2S/PCM_TX3CHMAP	0x50	I2S/PCM TX3 Channel Mapping Register
I2S/PCM_RXCHSEL	0x54	I2S/PCM RX Channel Select register
I2S/PCM_RXCHMAP	0x58	I2S/PCM RX Channel Mapping Register

### 8.6.7. I2S/PCM Register Description

#### 8.6.7.1. I2S/PCM Control Register(Default Value: 0x00060000)

Offset: 0x00			Register Name: I2S/PCM_CTL
Bit	R/W	Default/Hex	Description
31:19	/	/	/
18	R/W	1	BCLK_OUT 0: input

			1: output
17	R/W	1	LRCK_OUT 0: input 1: output
16	R/W	0	LRCKR_OUT 0: input 1: output
15:12	/	/	/
11	R/W	0	/
10	R/W	0	/
9	R/W	0	/
8	R/W	0	SDO0_EN 0: Disable, Hi-Z state 1: Enable
7	/	/	/
6	R/W	0	OUT Mute 0: normal transfer 1: force DOUT to output 0
5:4	R/W	0	MODE_SEL Mode Selection 0: PCM mode (offset 0: DSP_B; offset 1: DSP_A) 1: Left mode (offset 0: LJ mode; offset 1: I2S mode) 2: Right-Justified mode 3: Reserved
3	R/W	0	LOOP Loop back test 0: Normal mode 1: Loop back test When set '1', connecting the SDO0 with the SDI
2	R/W	0	TXEN Transmitter Block Enable 0: Disable 1: Enable
1	R/W	0	RXEN Receiver Block Enable 0: Disable 1: Enable
0	R/W	0	GEN Globe Enable A disable on this bit overrides any other block or channel enables. 0: Disable 1: Enable

**8.6.7.2. I2S/PCM Format Register0 (Default Value: 0x00000033)**

Offset: 0x04			Register Name: <b>I2S/PCM_FMT0</b>
Bit	R/W	Default/Hex	Description
31	R/W	0	SDI_SYNC_SEL 0: SDI use LRCK 1: SDI use LRCKR
30	R/W	0	LRCK_WIDTH (only apply in PCM mode ) LRCK width 0: LRCK = 1 BCLK width (short frame) 1: LRCK = 2 BCLK width (long frame)
29:20	R/W	0	LRCKR_PERIOD It is used to program the number of BCLKs per channel of sample frame. This value is interpreted as follow: PCM mode: Number of BCLKs within (Left + Right) channel width I2S / Left-Justified / Right-Justified mode: Number of BCLKs within each individual channel width (Left or Right) N+1 For example: n = 7: 8 BCLK width ... n = 1023: 1024 BCLKs width
19	R/W	0	LRCK_POLARITY/LRCKR_POLARITY When apply in I2S / Left-Justified / Right-Justified mode: 0: Left channel when LRCK is low 1: Left channel when LRCK is high When apply in PCM mode: 0: PCM LRCK/LRCKR asserted at the negative edge 1: PCM LRCK/LRCKR asserted at the positive edge
18	/	/	/
17:8	R/W	0	LRCK_PERIOD It is used to program the number of BCLKs per channel of sample frame. This value is interpreted as follow: PCM mode: Number of BCLKs within (Left + Right) channel width I2S / Left-Justified / Right-Justified mode: Number of BCLKs within each individual channel width (Left or Right) N+1 For example: n = 7: 8 BCLK width ... n = 1023: 1024 BCLKs width
7	R/W	0	BCLK_POLARITY 0: normal mode, negative edge drive and positive edge sample 1: invert mode, positive edge drive and negative edge sample
6:4	R/W	3	SR

			Sample Resolution 0: Reserved 1: 8-bit 2: 12-bit 3: 16-bit 4: 20-bit 5: 24-bit 6: 28-bit 7: 32-bit
3	R/W	0	EDGE_TRANSFER 0: SDO drive data and SDI sample data at the different BCLK edge 1: SDO drive data and SDI sample data at the same BCLK edge BCLK_POLARITY = 0, use negative edge BCLK_POLARITY = 1, use positive edge
2:0	R/W	0x3	SW Slot Width Select 0: Reserved 1: 8-bit 2: 12-bit 3: 16-bit 4: 20-bit 5: 24-bit 6: 28-bit 7: 32-bit

### 8.6.7.3. I2S/PCM Format Register1 (Default Value: 0x00000030)

Offset: 0x08			Register Name: I2S/PCM_FMT1
Bit	R/W	Default/Hex	Description
31:8	/	/	
7	R/W	0	RX MLS MSB / LSB First Select 0: MSB First 1: LSB First
6	R/W	0	TX MLS MSB / LSB First Select 0: MSB First 1: LSB First
5:4	R/W	3	SEXT Sign Extend in slot [sample resolution < slot width] 0: Zeros or audio gain padding at LSB position 1: Sign extension at MSB position 2: Reserved 3: Transfer 0 after each sample in each slot

3:2	R/W	0	RX_PDM PCM Data Mode 0: Linear PCM 1: reserved 2: 8-bits u-law 3: 8-bits A-law
1:0	R/W	0	TX_PDM PCM Data Mode 0: Linear PCM 1: reserved 2: 8-bits u-law 3: 8-bits A-law

**8.6.7.4. I2S/PCM Interrupt Status Register(Default Value: 0x00000010)**

Offset: 0x0C			Register Name: I2S/PCM_ISTA
Bit	R/W	Default/Hex	Description
31:7	/	/	/
6	R/W	0	TXU_INT TX FIFO Under run Pending Interrupt 0: No Pending Interrupt 1: FIFO Under run Pending Interrupt Write 1 to clear this interrupt
5	R/W	0	TXO_INT TX FIFO Overrun Pending Interrupt 0: No Pending Interrupt 1: FIFO Overrun Pending Interrupt Write '1' to clear this interrupt
4	R/W	1	TXE_INT TX FIFO Empty Pending Interrupt 0: No Pending IRQ 1: FIFO Empty Pending Interrupt when data in TX FIFO are less than TX trigger level Write '1' to clear this interrupt or automatic clear if interrupt condition fails.
3	/	/	/
2	R/W	0	RXU_INT RX FIFO Under run Pending Interrupt 0: No Pending Interrupt 1:FIFO Under run Pending Interrupt Write 1 to clear this interrupt
1	R/W	0	RXO_INT RX FIFO Overrun Pending Interrupt 0: No Pending IRQ



			1: FIFO Overrun Pending IRQ Write '1' to clear this interrupt
0	R/W	0	RXA_INT RX FIFO Data Available Pending Interrupt 0: No Pending IRQ 1: Data Available Pending IRQ when data in RX FIFO are more than RX trigger level Write '1' to clear this interrupt or automatic clear if interrupt condition fails.

**8.6.7.5. I2S/PCM RX FIFO Register(Default Value: 0x00000000)**

Offset: 0x10			Register Name: <b>I2S/PCM_RXFIFO</b>
Bit	R/W	Default/Hex	Description
31:0	R	0	RX_DATA RX Sample Host can get one sample by reading this register. The left channel sample data is first and then the right channel sample.

**8.6.7.6. I2S/PCM FIFO Control Register (Default Value: 0x000400F0)**

Offset: 0x14			Register Name: <b>I2S/PCM_FCTL</b>
Bit	R/W	Default/Hex	Description
31	R/W	0	HUB_EN Audio hub enable 0:disable 1:enable
30:26	/	/	/
25	R/W	0	FTX Write '1' to flush TX FIFO, self clear to '0'.
24	R/W	0	FRX Write '1' to flush RX FIFO, self clear to '0'.
23:19	/	/	/
18:12	R/W	0x40	TXTL TX FIFO Empty Trigger Level Interrupt and DMA request trigger level for TXFIFO normal condition Trigger Level = TXTL
11:10	/	/	/
9:4	R/W	0xF	RXTL RX FIFO Trigger Level Interrupt and DMA request trigger level for RXFIFO normal condition Trigger Level = RXTL + 1

3	/	/	/
2	R/W	0	<p>TXIM</p> <p>TX FIFO Input Mode (Mode 0, 1)</p> <p>0: Valid data at the MSB of TXFIFO register</p> <p>1: Valid data at the LSB of TXFIFO register</p> <p>Example for 20-bits transmitted audio sample:</p> <p>Mode 0: FIFO_I[31:0] = {APB_WDATA[31:12], 12'h0}</p> <p>Mode 1: FIFO_I[31:0] = {APB_WDATA[19:0], 12'h0}</p>
1:0	R/W	0	<p>RXOM</p> <p>RX FIFO Output Mode (Mode 0, 1, 2, 3)</p> <p>00: Expanding '0' at LSB of DA_RXFIFO register.</p> <p>01: Expanding received sample sign bit at MSB of DA_RXFIFO register.</p> <p>10: Truncating received samples at high half-word of DA_RXFIFO register and low half-word of DA_RXFIFO register is filled by '0'.</p> <p>11: Truncating received samples at low half-word of DA_RXFIFO register and high half-word of DA_RXFIFO register is expanded by its sign bit.</p> <p>Example for 20-bits received audio sample:</p> <p>Mode 0: APB_RDATA[31:0] = {FIFO_O[31:12], 12'h0}</p> <p>Mode 1: APB_RDATA [31:0] = {12{FIFO_O[31]}, FIFO_O[31:12]}</p> <p>Mode 2: APB_RDATA [31:0] = {FIFO_O[31:16], 16'h0}</p> <p>Mode 3: APB_RDATA [31:0] = {16{FIFO_O[31]}, FIFO_O[31:16]}</p>

**8.6.7.7. I2S/PCM FIFO Status Register (Default Value: 0x10800000)**

Offset: 0x18			Register Name: I2S/PCM_FSTA
Bit	R/W	Default/Hex	Description
31:29	/	/	/
28	R	1	<p>TXE</p> <p>TX FIFO Empty</p> <p>0: No room for new sample in TX FIFO</p> <p>1: More than one room for new sample in TX FIFO (&gt;= 1 word)</p>
27:24	/	/	/
23:16	R	0x80	<p>TXE_CNT</p> <p>TX FIFO Empty Space Word Counter</p>
15:9	/	/	/
8	R	0	<p>RXA</p> <p>RX FIFO Available</p> <p>0: No available data in RX FIFO</p> <p>1: More than one sample in RX FIFO (&gt;= 1 word)</p>
7	/	/	/
6:0	R	0	<p>RXA_CNT</p> <p>RX FIFO Available Sample Word Counter</p>

**8.6.7.8. I2S/PCM DMA & Interrupt Control Register(Default Value: 0x00000000)**

Offset: 0x1C			Register Name: <b>I2S/PCM_INT</b>
Bit	R/W	Default/Hex	Description
31:8	/	/	/
7	R/W	0	TX_DRQ TX FIFO Empty DRQ Enable 0: Disable 1: Enable
6	R/W	0	TXUI_EN TX FIFO Under run Interrupt Enable 0: Disable 1: Enable
5	R/W	0	TXOI_EN TX FIFO Overrun Interrupt Enable 0: Disable 1: Enable When set to '1', an interrupt happens when writing new audio data if TX FIFO is full.
4	R/W	0	TXEI_EN TX FIFO Empty Interrupt Enable 0: Disable 1: Enable
3	R/W	0	RX_DRQ RX FIFO Data Available DRQ Enable 0: Disable 1: Enable When set to '1', RXFIFO DMA Request line is asserted if Data is available in RX FIFO.
2	R/W	0	RXUI_EN RX FIFO Under run Interrupt Enable 0: Disable 1: Enable
1	R/W	0	RXOI_EN RX FIFO Overrun Interrupt Enable 0: Disable 1: Enable
0	R/W	0	RXAI_EN RX FIFO Data Available Interrupt Enable 0: Disable 1: Enable

**8.6.7.9. I2S/PCM TX FIFO Register(Default Value: 0x00000000)**

Offset: 0x20			Register Name: <b>I2S/PCM_TXFIFO</b>
Bit	R/W	Default/Hex	Description
31:0	W	0	TX_DATA TX Sample Transmitting left, right channel sample data should be written this register one by one. The left channel sample data is first and then the right channel sample.

**8.6.7.10. I2S/PCM Clock Divide Register(Default Value: 0x00000000)**

Offset: 0x24			Register Name: <b>I2S/PCM_CLKD</b>
Bit	R/W	Default/Hex	Description
31:9	/	/	/
8	R/W	0	MCLKO_EN 0: Disable MCLK Output 1: Enable MCLK Output Notes: Whether in Slave or Master mode, when this bit is set to 1, MCLK should be output.
7:4	R/W	0	BCLKDIV BCLK Divide Ratio from PLL2 0: reserved 1: Divide by 1 2: Divide by 2 3: Divide by 4 4: Divide by 6 5: Divide by 8 6: Divide by 12 7: Divide by 16 8: Divide by 24 9: Divide by 32 10: Divide by 48 11: Divide by 64 12: Divide by 96 13: Divide by 128 14: Divide by 176 15: Divide by 192
3:0	R/W	0	MCLKDIV MCLK Divide Ratio from PLL2 Output 0: reserved 1: Divide by 1 2: Divide by 2

			3: Divide by 4 4: Divide by 6 5: Divide by 8 6: Divide by 12 7: Divide by 16 8: Divide by 24 9: Divide by 32 10: Divide by 48 11: Divide by 64 12: Divide by 96 13: Divide by 128 14: Divide by 176 15: Divide by 192
--	--	--	---

**8.6.7.11. I2S/PCM TX Counter Register(Default Value: 0x00000000)**

Offset: 0x28			Register Name: <b>I2S/PCM_TXCNT</b>
Bit	R/W	Default/Hex	Description
31:0	R/W	0	<b>TX_CNT</b> TX Sample Counter The audio sample number of sending into TXFIFO. When one sample is put into TXFIFO by DMA or by host IO, the TX sample counter register increases by one. The TX sample counter register can be set to any initial valve at any time. After been updated by the initial value, the counter register should count on base of this initial value.

**8.6.7.12. I2S/PCM RX Counter Register(Default Value: 0x00000000)**

Offset: 0x2C			Register Name: <b>I2S/PCM_RXCNT</b>
Bit	R/W	Default/Hex	Description
31:0	R/W	0	<b>RX_CNT</b> RX Sample Counter The audio sample number of writing into RXFIFO. When one sample is written by Digital Audio Engine, the RX sample counter register increases by one. The RX sample counter register can be set to any initial valve at any time. After been updated by the initial value, the counter register should count on base of this initial value.

**8.6.7.13. I2S/PCM Channel Configuration Register(Default Value: 0x00000000)**

Offset: 0x30	Register Name: <b>I2S/PCM_CHCFG</b>
--------------	-------------------------------------

Bit	R/W	Default/Hex	Description
31:10	/	/	/
9	R/W	0	TX_SLOT_HIZ 0: normal mode for the last half cycle of BCLK in the slot 1: turn to hi-z state for the last half cycle of BCLK in the slot
8	R/W	0	TXn_STATE 0: transfer level 0 when not transferring slot 1: turn to hi-z state when not transferring slot
7	/	/	/
6:4	R/W	0	RX_SLOT_NUM RX Channel/Slot Number which between CPU/DMA and FIFO 0: 1 channel or slot ... 7: 8 channels or slots
3	/	/	/
2:0	R/W	0	TX_SLOT_NUM TX Channel/Slot Number which between CPU/DMA and FIFO 0: 1 channel or slot ... 7: 8 channels or slots

**8.6.7.14. I2S/PCM TXn Channel Select Register(Default Value: 0x00000000)**

Offset: 0x34 + n*4 (n = 0, 1, 2, 3)			Register Name: I2S/PCM_TXnCHSEL
Bit	R/W	Default/Hex	Description
31:14	/	/	/
13:12	R/W	0	TXn_OFFSET TXn offset tune, TXn data offset to LRCK 0: no offset n: data is offset by n BCLKs to LRCK
11:4	R/W	0	TXn_CHEN TXn Channel (slot) enable, bit[11:4] refer to slot [7:0]. When one or more slot(s) is(are) disabled, the affected slot(s) is(are) set to disable state 0: disable 1: enable
3	/	/	/
2:0	R/W	0	TXn_CHSEL TXn Channel (slot) number Select for each output 0: 1 channel / slot ... 7: 8 channels / slots

**8.6.7.15. I2S/PCM TXn Channel Mapping Register(Default Value: 0x00000000)**

Offset: 0x44 + n*4 (n = 0, 1, 2, 3)			Register Name: I2S/PCM_TXnCHMAP
Bit	R/W	Default/Hex	Description
31	/	/	/
30:28	R/W	0	TXn_CH7_MAP TXn Channel7 Mapping 0: 1st sample ... 7: 8th sample
27	/	/	/
26:24	R/W	0	TXn_CH6_MAP TXn Channel6 Mapping 0: 1st sample ... 7: 8th sample
23	/	/	/
22:20	R/W	0	TXn_CH5_MAP TXn Channel5 Mapping 0: 1st sample ... 7: 8th sample
19	/	/	/
18:16	R/W	0	TXn_CH4_MAP TXn Channel4 Mapping 0: 1st sample ... 7: 8th sample
15	/	/	/
14:12	R/W	0	TXn_CH3_MAP TXn Channel3 Mapping 0: 1st sample ... 7: 8th sample
11	/	/	/
10:8	R/W	0	TXn_CH2_MAP TXn Channel2 Mapping 0: 1st sample ... 7: 8th sample
7	/	/	/
6:4	R/W	0	TXn_CH1_MAP TXn Channel1 Mapping 0: 1st sample

			...
			7: 8th sample
3	/	/	/
2:0	R/W	0	TXn_CH0_MAP TXn Channel0 Mapping 0: 1st sample ... 7: 8th sample

**8.6.7.16. I2S/PCM RX Channel Select Register(Default Value: 0x00000000)**

Offset: 0x54			Register Name: I2S/PCM_RXCHSEL
Bit	R/W	Default/Hex	Description
31:14	/	/	/
13:12	R/W	0	RX_OFFSET RX offset tune, RX data offset to LRCK 0: no offset n: data is offset by n BCLKs to LRCK
11:3	/	/	
2:0	R/W	0	RX_CHSEL RX Channel (slot) number Select for input 0: 1 channel / slot ... 7: 8 channels / slots

**8.6.7.17. I2S/PCM RX Channel Mapping Register(Default Value: 0x00000000)**

Offset: 0x58			Register Name: I2S/PCM_RXCHMAP
Bit	R/W	Default/Hex	Description
31	/	/	/
30:28	R/W	0	RX_CH7_MAP RX Channel7 Mapping 0: 1st sample ... 7: 8th sample
27	/	/	/
26:24	R/W	0	RX_CH6_MAP RX Channel6 Mapping 0: 1st sample ... 7: 8th sample
23	/	/	/



22:20	R/W	0	RX_CH5_MAP RX Channel5 Mapping 0: 1st sample ... 7: 8th sample
19	/	/	/
18:16	R/W	0	RX_CH4_MAP RX Channel4 Mapping 0: 1st sample ... 7: 8th sample
15	/	/	/
14:12	R/W	0	RX_CH3_MAP RX Channel3 Mapping 0: 1st sample ... 7: 8th sample
11	/	/	/
10:8	R/W	0	RX_CH2_MAP RX Channel2 Mapping 0: 1st sample ... 7: 8th sample
7	/	/	/
6:4	R/W	0	RX_CH1_MAP TX Channel1 Mapping 0: 1st sample ... 7: 8th sample
3	/	/	/
2:0	R/W	0	RX_CH0_MAP RX Channel0 Mapping 0: 1st sample ... 7: 8th sample

## 8.7. OWA

### 8.7.1. Overview

The OWA(One Wire Audio) provides a serial bus interface for audio data between system. This interface is widely used for consumer audio connect.

The OWA includes the following features:

- IEC-60958 transmitter and receiver functionality
- Complies with SPDIF Interface
- Support channel status insertion for the transmitter
- Hardware Parity generation on the transmitter
- One 32×24bits FIFO (TX) for audio data transfer
- Programmable FIFO thresholds
- Interrupt and DMA support

### 8.7.2. Functional Description

#### 8.7.2.1. OWA Interface Pin List

Signal Name	Direction(M)	Description	Pin
OWA_DOUT	O	OWA output	PA17

#### 8.7.2.2. OWA Clock Requirement

Clock Name	Description	Requirement
apb_clk	APB bus clock	>13 MHz
s_clk	OWA serial access clock	4x24.576 MHz or 4x22.5792 MHz from CCU

#### 8.7.2.3. OWA Block Diagram

Figure 8-13 shows the OWA block diagram.

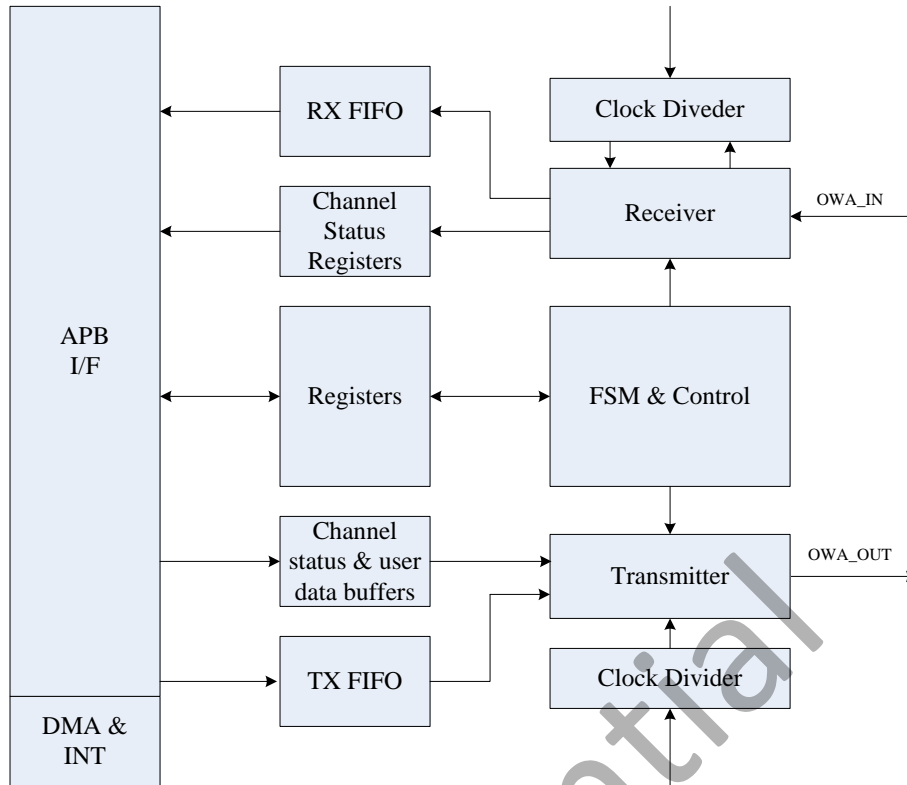

Figure 8-13. OWA Block Diagram

8.7.2.4. OWA Frame Format

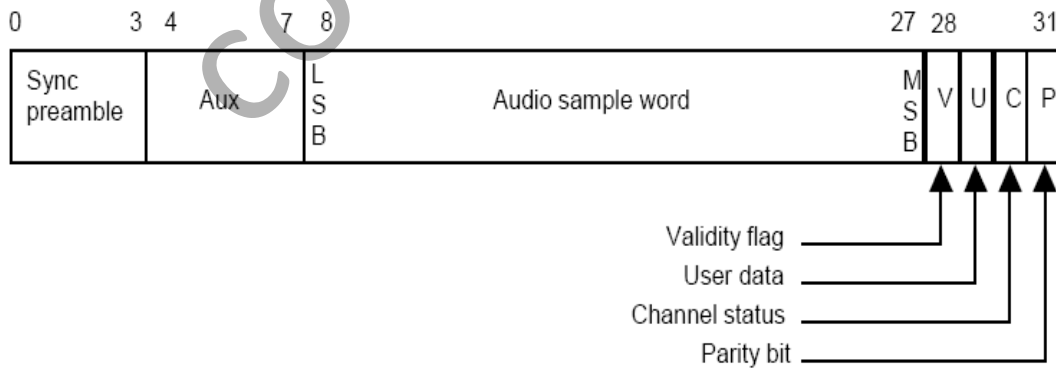

Figure 8-14. Sub-Frame Format

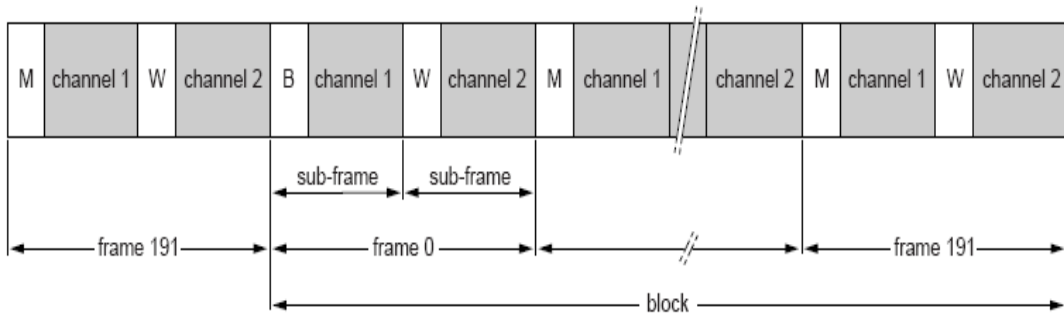

Figure 8-15. Frame/block format

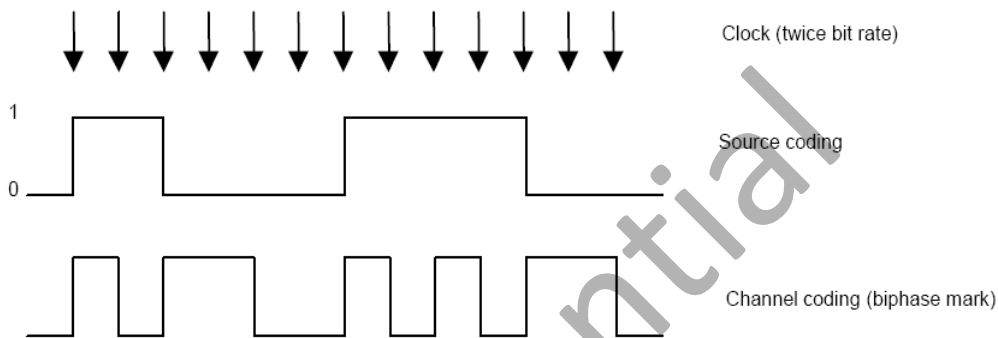

Figure 8-16. Biphase-Mark Encoding

### 8.7.2.5. Operation Modes

The software operation of the OWA is divided into five steps: system setup, OWA initialization, the channel setup, DMA setup and Enable/Disable module. These five setups are described in detail in the following sections.

#### 8.7.2.5.1. System setup and OWA initialization

The first step In the OWA initialization is properly programming the GPIO. Because the OWA port is a multiplex pin. You can find the function in the pin multiplex specification. The clock source for the OWA should be followed. At first you must reset the audio PLL in the CCMU. The second step, you must setup the frequency of the audio pll. After that, you must open the OWA gating. At last, you must open the OWA bus gating.

After the system setup, the register of OWA can be setup. At first, you should reset the OWA by write 1 to OWA\_CTL[0] and clear the TX/RX FIFO by write 1 to register OWA\_FCTL[17:16]. After that you should enable the globe enable bit by write 1 to OWA\_CTL[1] and clear the interrupt and TX/RX counter thought the OWA\_ISTA and SP\_TXCNT/SP\_RXCNT.

#### 8.7.2.5.2. The channel setup and DMA setup

The OWA support three methods to transfer the data. The most common way is DMA, the set of DMA can be found in the DMA spec. In this module, you just to enable the DRQ.

### 8.7.2.5.3. Enable and disable the OWA

To enable the function, you can enable TX/RX by write the OWA\_TX\_CFG[31] and OWA\_RX\_CFG[0]. After that, you must enable OWA by write the Globe Enable bit to 1 in the OWA\_CTL. The disable process is write the Globe Enable to 0.

### 8.7.3. OWA Register List

Module Name	Base Address
OWA	0x01C21000

Register Name	Offset	Description
OWA_GEN_CTL	0x00	OWA General Control
OWA_TX_CFG	0x04	OWA TX Configuration Register
OWA_RX_CFG	0x08	OWA RX Configuration Register
OWA_ISTA	0x0C	OWA Interrupt Status Register
OWA_RX_FIFO	0x10	OWA RX FIFO Register
OWA_FCTL	0x14	OWA FIFO Control Register
OWA_FSTA	0x18	OWA FIFO Status Register
OWA_INT	0x1C	OWA Interrupt Control Register
OWA_TX_FIFO	0x20	OWA TX FIFO Register
OWA_TX_CNT	0x24	OWA TX Counter Register
OWA_RX_CNT	0x28	OWA RX Counter Register
OWA_TX_CHSTA0	0x2C	OWA TX Channel Status Register0
OWA_TX_CHSTA1	0x30	OWA TX Channel Status Register1
OWA_RX_CHSTA0	0x34	OWA RX Channel Status Register0
OWA_RX_CHSTA1	0x38	OWA RX Channel Status Register1

### 8.7.4. OWA Register Description

#### 8.7.4.1. OWA General Control Register(Default Value : 0x00000080)

Offset: 0x00			Register Name: <b>OWA_CTL</b>
Bit	R/W	Default/Hex	Description
31:10	/	/	/
9:4	R/W	0x08	MCLK_DIV_RATIO Mclk divide Ratio Note: only support 2n divide ratio(n=1~31)

3:2	/	/	/
1	R/W	0	GEN Globe Enable A disable on this bit overrides any other block or channel enables and flushes all FIFOs. 0: Disable 1: Enable
0	R/W	0	RST Reset 0: Normal 1: Reset <i>Self clear to 0</i>

**8.7.4.2. OWA TX Configure Register(Default Value: 0x00000F0)**

Offset: 0x04			Register Name: <b>OWA_TX_CFG</b>
Bit	R/W	Default/Hex	Description
31	R/W	0	TX_SINGLE_MODE Tx single channel mode 0: Disable 1: Eanble
30:18	/	/	/
17	R/W	0	ASS Audio sample select with TX FIFO under run when 0: sending 0 1: sending the last audio <i>Note: This bit is only valid in PCM mode</i>
16	R/W	0	TX_AUDIO TX data type 0: Linear PCM (Valid bit of both sub-frame set to 0 ) 1: Non-audio(Valid bit of both sub-frame set to 1)
15:9	/	/	/
8:4	R/W	0xF	TX_RATIO TX clock divide Ratio <i>Note: clock divide ratio = TX TATIO +1</i>
3:2	R/W	0	TX_SF TX Sample format: 00: 16bit 01: 20bit 10: 24bit 11: Reserved
1	R/W	0	TX_CHM CHSTMODE

			0: Channel status A&B set to 0 1: Channel status A&B generated form TX_CHSTA
0	R/W	0	TXEN 0: disabled 1: enabled

#### 8.7.4.3. OWA RX Configure Register(Default Value: 0x00000000)

Offset: 0x08			Register Name: <b>OWA_RX_CFG</b>
Bit	R/W	Default/Hex	Description
31:5	/	/	/
4	R	0	RX_LOCK_FLAG 0: unlock 1: lock
3	R/W	0	RX_CHST_SRC 0: RX_CH_STA Register holds status from Channel A 1: RX_CH_STA Register holds status from Channel B
2	/	/	/
1	R/W	0	CHST_CP Channel status Capture 0: Idle or capture end 1: Capture Channel status start Notes: When set to '1', the channel status information is capturing, the bit will clear to '0' after captured.
0	R/W	0	RXEN 0: disabled 1: enabled

#### 8.7.4.4. OWA Interrupt Status Register(Default Value: 0x00000010)

Offset: 0x0C			Register Name: <b>OWA_ISTA</b>
Bit	R/W	Default/Hex	Description
31:19	/	/	/
18	R/W	0	RX_LOCK_INT 0: No pending IRQ 1: RX lock Pending Interrupt (RX_LOCK_FLAG 0→1) <i>Write "1" to clear this interrupt</i>
17	R/W	0	RX_UNLOCK_INT RX Unlock Pending Interrupt 0: No pending IRQ 1: RX Unlock Pending Interrupt (RX_LOCK_FLAG 1→0) <i>Write "1" to clear this interrupt</i>

16	R/W	0	RX_PARERRI_INT RX Parity Error Pending Interrupt 0: No pending IRQ 1: RX Parity Error Pending Interrupt <i>Write "1" to clear this interrupt</i>
15:7	/	/	/
6	R/W	0	TXU_INT TX FIFO Under run Pending Interrupt 0: No pending IRQ 1: FIFO Under run Pending Interrupt <i>Write "1" to clear this interrupt</i>
5	R/W	0	TXO_INT TX FIFO Overrun Pending Interrupt 0: No Pending IRQ 1: FIFO Overrun Pending Interrupt <i>Write "1" to clear this interrupt</i>
4	R/W	1	TXE_INT TX FIFO Empty Pending Interrupt 0: No Pending IRQ 1: FIFO Empty Pending Interrupt <i>Write "1" to clear this interrupt or automatically clear if interrupt condition fails.</i>
3:2	/	/	/
1	R/W	0	RXO_INT RX FIFO Overrun Pending Interrupt 0: FIFO Overrun Pending <i>Write "1" to clear this interrupt</i>
0	R/W	0	RXA_INT RX FIFO Available Pending Interrupt 0: No Pending IRQ 1: Data Available Pending IRQ <i>Write "1" to clear this interrupt or automatically clear if interrupt condition fails</i>

#### 8.7.4.5. OWA RX FIFO Register(Default Value: 0x00000000)

Offset: 0x10			Register Name: <b>OWA_RXFIFO</b>
Bit	R/W	Default/Hex	Description
31:0	R	0	RX_DATA Host can get one sample by reading this register, the A channel data is first and then the B channel data



**8.7.4.6. OWA FIFO Control Register(Default Value: 0x00001078)**

Offset: 0x14			Register Name: <b>OWA_FCTL</b>
Bit	R/W	Default/Hex	Description
31	R/W	0	HUB_EN Audio hub enable 0 : Disable 1: Enable
30:18	/	/	/
17	R/W	0	FTX Write "1" to flush TX FIFO, self clear to "0"
16	R/W	0	FRX Write "1" to flush RX FIFO, self clear to "0"
15:13	/	/	/
12:8	R/W	0x10	TXTL TX FIFO empty Trigger Level Interrupt and DMA request trigger level for TX FIFO normal condition Trigger Level = TXTL
7:3	R/W	0x0F	RXTL RX FIFO Trigger Level Interrupt and DMA request trigger level for RX FIFO normal condition Trigger Level = RXTL + 1
2	R/W	0	TXIM TX FIFO Input Mode(Mode0, 1) 0: Valid data at the MSB of OWA_TXFIFO register 1: Valid data at the LSB of OWA_TXFIFO register Example for 20-bits transmitted audio sample: Mode 0: FIFO_I[23:0] = {TXFIFO[31:12], 4'h0} Mode 1: FIFO_I[23:0] = {TXFIFO[19:0], 4'h0}
1:0	R/W	0	RXOM RX FIFO Output Mode(Mode 0,1,2,3) 00: Expanding "0" at LSB of SPDIP_RXFIFO register 01: Expanding received sample sign bit at MSB of OWA_RXFIFO register 10: Truncating received samples at high half-word of OWA_RXFIFO register and low half-word of AC_FIFO register is filled by "0" 11: Truncating received samples at low half-word of OWA_RXFIFO register and high half-word of AC_FIFO register is expanded by its sign bit Mode0: RXFIFO[31:0] = {FIFO_O[23:0], 8'h0} Mode 1: RXFIFO[31:0] = {8'FIFO_O[23], FIFO_O[23:0]} Mode 2: RXFIFO[31:0] = {FIFO_O[23:8], 16'h0} Mode 3: RXFIFO[31:0] = {16'FIFO_O[23], FIFO_O[23:8]}

**8.7.4.7. OWA FIFO Status Register(Default Value: 0x00006000)**

Offset: 0x18			Register Name: <b>OWA_FSTA</b>
Bit	R/W	Default/Hex	Description
31:15	/	/	/
14	R	1	TXE TX FIFO Empty (indicate FIFO is not full) 0: No room for new sample in TX FIFO 1: More than one room for new sample in TX FIFO ( >=1 word )
13:8	R	0x20	TXE_CNT TX FIFO Empty Space Word counter
7	/	/	/
6	R	0	RXA RX FIFO Available 0: No available data in RX FIFO 1: More than one sample in RX FIFO ( >=1 word )
5:0	R	0	RXA_CNT RX FIFO Available Sample Word counter

**8.7.4.8. OWA Interrupt Control Register(Default Value: 0x00000000)**

Offset: 0x1C			Register Name: <b>OWA_INT</b>
Bit	R/W	Default/Hex	Description
31:19	/	/	/
18	R/W	0	RX_LOCKI_EN RX LOCK Interrupt enable 0: Disable 1: Enable
17	R/W	0	RX_UNLOCKI_EN RX UNLOCK Interrupt enable 0: Disable 1: Enable
16	R/W	0	RX_PARERRI_EN RX PARITY ERORR Interrupt enable 0: Disable 1: Enable
15:8	/	/	/
7	R/W	0	TX_DRQ TX FIFO Empty DRQ Enable 0: Disable 1: Enable
6	R/W	0	TXUI_EN TX FIFO Under run Interrupt Enable

			0: Disable 1: Enable
5	R/W	0	TXOI_EN TX FIFO Overrun Interrupt Enable 0: Disable 1: Enable
4	R/W	0	TXEI_EN TX FIFO Empty Interrupt Enable 0: Disable 1: Enable
3	/	/	/
2	R/W	0	RX_DRQ RX FIFO Data Available DRQ Enable When set to "1", RX FIFO DMA Request is asserted if Data is available in RX FIFO 0: Disable 1: Enable
1	R/W	0	RXOI_EN RX FIFO Overrun Interrupt Enable 0: Disable 1: Enable
0	R/W	0	RXAI_EN RX FIFO Data Available Interrupt Enable 0: Disable 1: Enable

#### 8.7.4.9. OWA TX FIFO Register(Default Value: 0x00000000)

Offset: 0x20			Register Name: <b>OWA_TXFIFO</b>
Bit	R/W	Default/Hex	Description
31:0	W	0	TX_DATA Transmitting A, B channel data should be written this register one by one. The A channel data is first and then the B channel data.

#### 8.7.4.10. OWA TX Counter Register(Default Value: 0x00000000)

Offset: 0x24			Register Name: <b>OWA_TX_CNT</b>
Bit	R/W	Default/Hex	Description
31:0	R/W	0	TX_CNT TX Sample counter The audio sample number of writing into TX FIFO. When one sample is written by DMA or by host IO, the TX sample counter register increases by

			one. The TX Counter register can be set to any initial value at any time. After been updated by the initial value, the counter register should count on base of this value.
--	--	--	---

**8.7.4.11. OWA RX Counter Register(Default Value: 0x00000000)**

Offset: 0x28			Register Name: <b>OWA_RX_CNT</b>
Bit	R/W	Default/Hex	Description
31:0	R/W	0	RX_CNT RX Sample counter The audio sample number of writing into RX FIFO. When one sample is written by Codec, the RX sample counter register increases by one. The RX Counter register can be set to any initial value at any time. After been updated by the initial value, the counter register should count on base of this value.

**8.7.4.12. OWA TX Channel Status Register0(Default Value: 0x00000000)**

Offset: 0x2C			Register Name: <b>OWA_TX_CHSTA0</b>
Bit	R/W	Default/Hex	Description
31: 30	/	/	/
29:28	R/W		CA Clock Accuracy 00: Level 2 01: Level 1 10: Level 3 11: not matched
27:24	R/W		FREQ Sampling frequency 0000: 44.1kHz                      1000: Reserved 0001: not indicated                1001: 768kHz 0010: 48kHz                            1010: 96kHz 0011: 32kHz                            1011: Reserved 0100: 22.05kHz                        1100:176.4kHz 0101: Reserved                        1101: Reserved 0110: 24kHz                            1110: 192kHz 0111: Reserved                        1111: Reserved
23:20	R/W	0	CN Channel Number
19:16	R/W	0	SN Source Number
15:8	R/W	0	CC

			Category code Indicates the kind of equipment that generates the digital audio interface signal.
7:6	R/W	0	MODE Mode 00: Default Mode 01~11: Reserved
5:3	R/W	0	EMP Emphasis Additional format information For bit 1 = "0", Linear PCM audio mode: 000: 2 audio channels without pre-emphasis 001: 2 audio channels with 50 $\mu$ s / 15 $\mu$ s pre-emphasis 010: Reserved (for 2 audio channels with pre-emphasis) 011: Reserved (for 2 audio channels with pre-emphasis) 100~111: Reserved For bit 1 = "1", other than Linear PCM applications: 000: Default state 001~111: Reserved
2	R/W	0	CP Copyright 0: copyright is asserted 1: no copyright is asserted
1	R/W	0	TYPE Audio Data Type 0: Linear PCM Samples 1: For none-linear PCM audio such as AC3, DTS, MPEG audio
0	R/W	0	PRO Application type 0: Consumer Application 1: Professional Application Note: This bit must be fixed to "0"

**8.7.4.13. OWA TX Channel Status Register1(Default Value: 0x00000000)**

Offset: 0x30			Register Name: <b>OWA_TX_CHSTA1</b>
Bit	R/W	Default/Hex	Description
31:10	/	/	/
9:8	R/W	0	CGMS_A 00: Copying is permitted without restriction 01: One generation of copies may be made 10: Condition not be used 11: No copying is permitted
7:4	R/W	0	ORIG_FREQ

			<p>Original sampling frequency</p> <p>0000: not indicated</p> <p>0001: 192kHz</p> <p>0010: 12kHz</p> <p>0011: 176.4kHz</p> <p>0100: Reserved</p> <p>0101: 96kHz</p> <p>0110: 8kHz</p> <p>0111: 88.2kHz</p> <p>1000: 16kHz</p> <p>1001: 24kHz</p> <p>1010: 11.025kHz</p> <p>1011: 22.05kHz</p> <p>1100: 32kHz</p> <p>1101: 48kHz</p> <p>1110: Reserved</p> <p>1111: 44.1kHz</p>
3:1	R/W	0	<p>WL</p> <p>Sample word length</p> <p>For bit 0 = "0":</p> <p>000: not indicated</p> <p>001: 16 bits</p> <p>010: 18 bits</p> <p>100: 19 bits</p> <p>101: 20 bits</p> <p>110: 17 bits</p> <p>111: Reserved</p> <p>For bit 0 = "1":</p> <p>000: not indicated</p> <p>001: 20 bits</p> <p>010: 22 bits</p> <p>100: 23 bits</p> <p>101: 24 bits</p> <p>110: 21 bits</p> <p>111: Reserved</p>
0	R/W	0	<p>MWL</p> <p>Max Word length</p> <p>0: Maximum audio sample word length is 20 bits</p> <p>1: Maximum audio sample word length is 24 bits</p>

**8.7.4.14. OWA RX Channel Status Register0(Default Value: 0x00000000)**

Offset: 0x34	Register Name: <b>OWA_RX_CHSTAO</b>
--------------	-------------------------------------

Bit	R/W	Default/Hex	Description
31:30	/	/	/
29:28	R/W		CA Clock Accuracy 00: Level 2 01: Level 1 10: Level 3 11: not matched
27:24	R/W		FREQ Sampling frequency 0000: 44.1kHz                   1000: Reserved 0001: not indicated           1001: 768kHz 0010: 48kHz                    1010: 96kHz 0011: 32kHz                    1011: Reserved 0100: 22.05kHz                1100:176.4kHz 0101: Reserved                1101: Reserved 0110: 24kHz                    1110: 192kHz 0111: Reserved                1111: Reserved
23:20	R/W	0	CN Channel Number
19:16	R/W	0	SN Source Number
15:8	R/W	0	CC Category code Indicates the kind of equipment that generates the digital audio interface signal.
7:6	R/W	0	MODE Mode 00: Default Mode 01~11: Reserved
5:3	R/W	0	EMP Emphasis Additional format information For bit 1 = "0", Linear PCM audio mode: 000: 2 audio channels without pre-emphasis 001: 2 audio channels with 50 $\mu$ s / 15 $\mu$ s pre-emphasis 010: Reserved (for 2 audio channels with pre-emphasis) 011: Reserved (for 2 audio channels with pre-emphasis) 100~111: Reserved For bit 1 = "1", other than Linear PCM applications: 000: Default state 001~111: Reserved
2	R/W	0	CP Copyright 0: copyright is asserted

			1: no copyright is asserted
1	R/W	0	TYPE Audio Data Type 0: Linear PCM Samples 1: For none-linear PCM audio such as AC3, DTS, MPEG audio
0	R/W	0	PRO Application type 0: Consumer Application 1: Professional Application

**8.7.4.15. OWA RX Channel Status Register1(Default Value: 0x00000000)**

Offset: 0x38			Register Name: <b>OWA_CH_STA0</b>
Bit	R/W	Default/Hex	Description
31:10	/	/	/
9:8	R/W	0	CGMS_A 00: Copying is permitted without restriction 01: One generation of copies may be made 10: Condition not be used 11: No copying is permitted
7:4	R/W	0	ORIG_FREQ Original sampling frequency 0000: not indicated 0001: 192kHz 0010: 12kHz 0011: 176.4kHz 0100: Reserved 0101: 96kHz 0110: 8kHz 0111: 88.2kHz 1000: 16kHz 1001: 24kHz 1010: 11.025kHz 1011: 22.05kHz 1100: 32kHz 1101: 48kHz 1110: Reserved 1111: 44.1kHz
3:1	R/W	0	WL Sample word length For bit 0 = "0": 000: not indicated 001: 16 bits 010: 18 bits



			100: 19 bits 101: 20 bits 110: 17 bits 111: Reserved For bit 0 = "1": 000: not indicated 001: 20 bits 010: 22 bits 100: 23 bits 101: 24 bits 110: 21 bits 111: Reserved
0	R/W	0	MWL Max Word length 0: Maximum audio sample word length is 20 bits 1: Maximum audio sample word length is 24 bits

Confidential

## 8.8. SCR

### 8.8.1. Overview

The Smart Card Reader (SCR) is a communication controller that transmits data between the system and Smart Card. The controller can perform a complete smart card session, including card activation, card deactivation. Cold/warm reset, Answer to Reset (ATR) response reception, data transfers, etc.

The SCR includes the following features:

- Supports APB slave interface for easy integration with AMBA-based host systems
- Supports the ISO/IEC 7816-3:1997(E) and EMV2000 (4.0) Specifications
- Performs functions needed for complete smart card sessions, including:
  - Card activation and deactivation
  - Cold/warm reset
  - Answer to Reset (ATR) response reception
  - Data transfers to and from the card
- Supports adjustable clock rate and bit rate
- Configurable automatic byte repetition
- Support commonly used communication protocols:
  - T=0 for asynchronous half-duplex character transmission
  - T=1 for asynchronous half-duplex block transmission
- Support FIFOs for receive and transmit buffers (up to 128 characters) with threshold
- Support configurable timing functions:
  - Smart card activation time
  - Smart card reset time
  - Guard time
  - Timeout timers
- Supports synchronous and any other non-ISO 7816 and non-EMV cards

### 8.8.2. Block Diagram

The Top Diagram of Smart Card Reader is below:

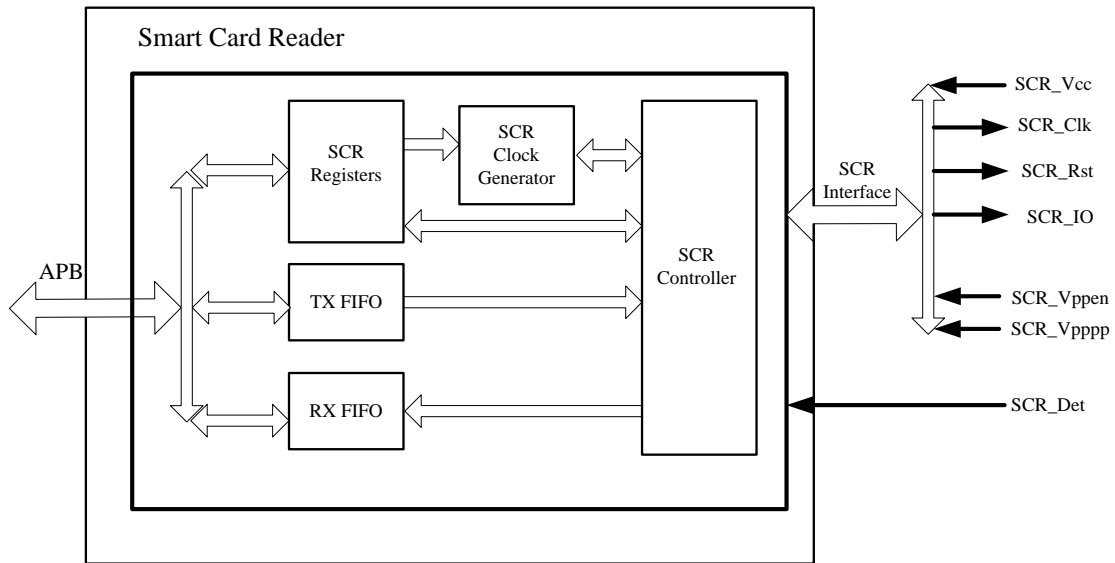

Figure 8-17. SCR Block Diagram

### 8.8.3. SCR Timing Diagram

Please refer ISO/IEC 7816 and EMV2000 Specification.

### 8.8.4. SCR Special Requirement

#### 8.8.4.1. Clock Generator

The Clock Generator generates the Smart Card Clock signal and the Baud Clock Impulse signal, used in timing the Smart Card Reader.

The Smart Card Clock signal is used as the main clock for the smart card. Its frequency can be adjusted using the Smart Card Clock Divisor (SCCDIV). This value is used to divide the system clock. The SCCLK frequency is given by the following equation:

$$f_{sclk} = \frac{f_{sysclk}}{2 * (SCCDIV + 1)}$$

$f_{sclk}$  -- Smart Card Clock Frequency

$f_{sysclk}$  -- System Clock (PCLK) Frequency

The **Baud Clock Impulse** signal is used to transmit and receive serial between the Smart Card Reader and the Smart Card. The baud rate can be modified using the Baud Clock Divisor (BAUDDIV). The value is used to divide the system

clock. The BAUD rate is given by the following equation:

$$BAUD = \frac{f_{sysclk}}{2 * (BAUDDIV + 1)}$$

BAUD -- Baud rate of the data stream between Smart Card and Reader.

The duration of one bit, Elementary Time Unit (ETU), is defined in the ISO/IEC 7816-3 specification. During the first answer to reset response after the cold reset, the initial ETU must be equal to 372 Smart Card Clock Cycles.

$$\frac{1}{BAUD} = ETU = \frac{372}{f_{scclk}}$$

In this case, the BAUDDIV should be

$$BAUDDIV = \frac{372 * f_{sysclk}}{2 * f_{scclk}} - 1 = 372 * (SCCDIV + 1) - 1.$$

After the ATR is completed, the ETU can be changed according to Smart Card abilities.

$$\frac{1}{BAUD} = ETU = \frac{F}{D} * \frac{1}{f_{scclk}}$$

Parameters F and D are defined in the ISO/IEC 7816-3 Specification.

### 8.8.4.2. SCIO Pad Configuration

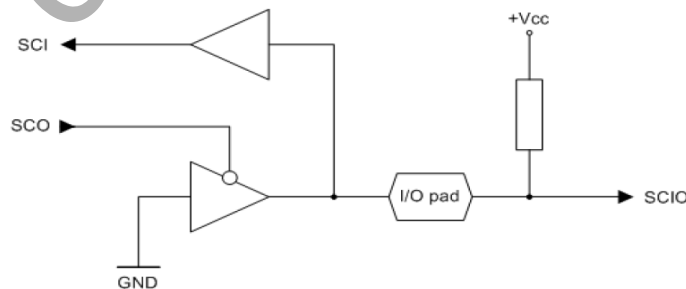

Figure 8-18. SCIO Pad Configuration Diagram

### 8.8.5. SCR Register List

Module Name	Base Address
SCR	0x01C2C400

Register Name	Offset	Description
---------------	--------	-------------

SCR_CSR	0x000	Smart Card Reader Control and Status Register
SCR_INTEN	0x004	Smart Card Reader Interrupt Enable Register 1
SCR_INTST	0x008	Smart Card Reader Interrupt Status Register 1
SCR_FCSR	0x00c	Smart Card Reader FIFO Control and Status Register
SCR_FCNT	0x010	Smart Card Reader RX and TX FIFO Counter Register
SCR_RPT	0x014	Smart Card Reader RX and TX Repeat Register
SCR_DIV	0x018	Smart Card Reader Clock and Baud Divisor Register
SCR_LTIM	0x01c	Smart Card Reader Line Time Register
SCR_CTIM	0x020	Smart Card Reader Character Time Register
SCR_LCTLR	0x030	Smart Card Reader Line Control Register
SCR_FIFO	0x100	Smart Card Reader RX and TX FIFO Access Point

### 8.8.6. SCR Register Description

#### 8.8.6.1. Smart Card Reader Control and Status Register(Default Value: 0x00000000)

Offset: 0x00			Register Name: SCR_CSR
Bit	R/W	Default/Hex	Description
31	R	0	<b>SCDET</b> Smart Card Detected This bit is set to '1' when the scdetect input is active at least for a debounce time.
30	/	/	/
24	R/W	0	<b>SCDETPOL</b> Smart Card Detect Polarity This bit set polarity of scdetect signal. 0: Low Active 1: High Active
23:22	R/W	0	<b>Protocol Selection (PTLSEL)</b> 0x0 – T=0. 0x1 – T=1, no character repeating and no guard time is used when T=1 protocol is selected. 0x2 – Reserved 0x3 – Reserved
21	R/W	0	<b>ATRSTFLUSH</b> ATR Start Flush FIFO When enabled, both FIFOs are flushed before the ATR is started.
20	R/W	0	<b>TSRXE</b> TS Receive Enable When set to '1', the TS character (the first ATR character) will be store in RXFIFO during card session.
19	R/W	0	<b>CLKSTPPOL</b>

			Clock Stop Polarity The value of the sclck output during the clock stop state.
18	R/W	0	PECRXE Parity Error Character Receive Enable Enables storage of the characters received with wrong parity in RX FIFO.
17	R/W	0	MSBF MSB First When high, inverse bit ordering convention (msb to lsb) is used.
16	R/W	0	DATAPOL Data Polarity When high, inverse level convention is used (A='1', Z='0').
15:12	/	/	/
11	R/W	0	DEACT Deactivation. Setting of this bit initializes the deactivation sequence. When the deactivation is finished, the DEACT bit is automatically cleared.
10	R/W	0	ACT Activation. Setting of this bit initializes the activation sequence. When the activation is finished, the ACT bit is automatically cleared.
9	R/W	0	WARMRST Warm Reset Command. Writing '1' to this bit initializes Warm Reset of the Smart Card. This bit is always read as '0'.
8	R/W	0	CLKSTOP Clock Stop. When this bit is asserted and the smart card I/O line is in 'Z' state, the SCR core stops driving of the smart card clock signal after the CLKSTOPDELAY time expires. The smart card clock is restarted immediately after the CLKSTOP signal is deasserted. New character transmission can be started after CLKSTARTDELAY time. The expiration of both times is signaled by the CLKSTOPRUN bit in the interrupt registers.
7:3	/	/	Reserved
2	R/W	0	GINTEN Global Interrupt Enable. When high, IRQ output assertion is enabled.
1	R/W	0	RXEN Receiving Enable. When enabled the characters sent by the Smart Card are received by the UART and stored in RX FIFO. Receiving is internally disabled while a transmission is in progress.
0	R/W	0	TXEN Transmission Enable. When enabled the characters are read from TX FIFO and transmitted through UART to the Smart Card.

### 8.8.6.2. Smart Card Reader Interrupt Enable Register(Default Value: 0x00000000)

Offset: 0x04			Register Name: <b>SCR_INTEN</b>
Bit	R/W	Default/Hex	Description
31:24	/	/	/

23	R/W	0	SCDEA Smart Card Deactivation Interrupt Enable.
22	R/W	0	SCACT Smart Card Activation Interrupt Enable.
21	R/W	0	SCINS Smart Card Inserted Interrupt Enable.
20	R/W	0	SCREM Smart Card Removed Interrupt Enable.
19	R/W	0	ATRDONE ATR Done Interrupt Enable.
18	R/W	0	ATRFAIL ATR Fail Interrupt Enable.
17	R/W	0	C2CFULL Two Consecutive Characters Limit Interrupt Enable.
16	R/W	0	CLKSTOPRUN Smart Card Clock Stop/Run Interrupt Enable.
15:13	/	/	/
12	R/W	0	RXPERR RX Parity Error Interrupt Enable.
11	R/W	0	RXDONE RX Done Interrupt Enable.
10	R/W	0	RXFIFOTH RX FIFO Threshold Interrupt Enable.
9	R/W	0	RXFIFOFULL RX FIFO Full Interrupt Enable.
8	/	/	/
7:5	/	/	/
4	R/W	0	TXPERR TX Parity Error Interrupt Enable.
3	R/W	0	TXDONE TX Done Interrupt Enable.
2	R/W	0	TXFIFOTH TX FIFO Threshold Interrupt Enable.
1	R/W	0	TXFIFOEMPTY TX FIFO Empty Interrupt Enable.
0	R/W	0	TXFIFODONE TX FIFO Done Interrupt Enable.

### 8.8.6.3. Smart Card Reader Interrupt Status Register(Default Value: 0x00000000)

Offset: 0x08			Register Name: <b>SCR_INTST</b>
Bit	R/W	Default/Hex	Description
31:24	/	/	/

23	R/W	0	SCDEA Smart Card Deactivation Interrupt. When enabled, this interrupt is asserted after the Smart Card deactivation sequence is complete.
22	R/W	0	SCACT Smart Card Activation Interrupt. When enabled, this interrupt is asserted after the Smart Card activation sequence is complete.
21	R/W	0	SCINS Smart Card Inserted Interrupt. When enabled, this interrupt is asserted after the smart card insertion.
20	R/W	0	SCREM Smart Card Removed Interrupt. When enabled, this interrupt is asserted after the smart card removal.
19	R/W	0	ATRDONE ATR Done Interrupt. When enabled, this interrupt is asserted after the ATR sequence is successfully completed.
18	R/W	0	ATRFAIL ATR Fail Interrupt. When enabled, this interrupt is asserted if the ATR sequence fails.
17	R/W	0	C2CFULL Two Consecutive Characters Limit Interrupt. When enabled, this interrupt is asserted if the time between two consecutive characters, transmitted between the Smart Card and the Reader in both directions, is equal the Two Characters Delay Limit described below. The C2CFULL interrupt is internally enabled from the ATR start to the deactivation or ATR restart initialization. It is recommended to use this counter to detect unresponsive Smart Cards.
16	R/W	0	CLKSTOPRUN Smart Card Clock Stop/Run Interrupt. When enabled, this interrupt is asserted in two cases: <ul style="list-style-type: none"> <li>● When the smart card clock is stopped.</li> <li>● When the new character can be started after the clock restart.</li> </ul> To distinguish between the two interrupt cases, we recommend reading the CLKSTOP bit in SCR_CTRL1 register.
15:13	/	/	/
12	R/W	0	RXPERR RX Parity Error Interrupt. When enabled, this interrupt is asserted after the character with wrong parity was received when the number of repeated receptions exceeds RXREPEAT value or T=1 protocol is used.
11	R/W	0	RXDONE RX Done Interrupt. When enabled, this interrupt is asserted after a character was received from the Smart Card.
10	R/W	0	RXFIFOTH RX FIFO Threshold Interrupt. When enabled, this interrupt is asserted if the number of bytes in RX FIFO is equal or exceeds the RX FIFO threshold.
9	R/W	0	RXFIFOFULL



			RX FIFO Full Interrupt. When enabled, this interrupt is asserted if the RX FIFO is filled up.
8	/	/	/
7:5	/	/	/
4	R/W	0	TXPERR TX Parity Error Interrupt. When enabled, this interrupt is asserted if the Smart Card signals wrong character parity during the guard time after the character transmission was repeated TXREPEAT times or T=1 protocol is used.
3	R/W	0	TXDONE TX Done Interrupt. When enabled, this interrupt is asserted after one character was transmitted to the smart card.
2	R/W	0	TXFIFOTH TX FIFO Threshold Interrupt. When enabled, this interrupt is asserted if the number of bytes in TX FIFO is equal or less than the TX FIFO threshold.
1	R/W	0	TXFIFOEMPTY TX FIFO Empty Interrupt. When enabled, this interrupt is asserted if the TX FIFO is emptied out.
0	R/W	0	TXFIFODONE TX FIFO Done Interrupt. When enabled, this interrupt is asserted after all bytes from TX FIFO were transferred to the Smart Card.

**Note:** This register provides information about the state of each interrupt bit. You can clear the register bits individually by writing '1' to a bit you intend to clear.

#### 8.8.6.4. Smart Card Reader FIFO Control and Status Register(Default Value: 0x00000000)

Offset: 0x0C			Register Name: SCR_FCSR
Bit	R/W	Default/Hex	Description
31:11	/	/	/
10	R/W	0	RXFIFOFLUSH Flush RX FIFO. RX FIFO is flushed, when '1' is written to this bit.
9	R	0	RXFIFOFULL RX FIFO Full.
8	R	1	RXFIFOEMPTY RX FIFO Empty.
7:3	/	/	/
2	R/W	0	TXFIFOFLUSH Flush TX FIFO. TX FIFO is flushed, when '1' is written to this bit.
1	R	0	TXFIFOFULL TX FIFO Full.
0	R	1	TXFIFOEMPTY TX FIFO Empty.

**8.8.6.5. Smart Card Reader FIFO Counter Register(Default Value: 0x00000000)**

Offset: 0x10			Register Name: <b>SCR_FIFOCNT</b>
Bit	R/W	Default/Hex	Description
31:24	R/W	0	<b>RXFTH</b> RX FIFO Threshold These bits set the interrupt threshold of RX FIFO. The interrupt is asserted when the number of bytes it receives is equal to, or exceeds the threshold.
23:16	R/W	0	<b>TXFTH</b> TX FIFO Threshold These bits set the interrupt threshold of TX FIFO. The interrupt is asserted when the number of bytes in TX FIFO is equal to or less than the threshold.
15:8	R	0	<b>RXFCNT</b> RX FIFO Counter These bits provide the number of bytes stored in the RXFIFO.
7:0	R	0	<b>TXFCNT</b> TX FIFO Counter These bits provide the number of bytes stored in the TXFIFO.

**8.8.6.6. Smart Card Reader Repeat Control Register(Default Value: 0x00000000)**

Offset: 0x14			Register Name: <b>SCR_REPEAT</b>
Bit	R/W	Default/Hex	Description
31:8	/	/	/
7:4	R/W	0	<b>RXRPT</b> RX Repeat This is a 4-bit register that specifies the number of attempts to request character re-transmission after wrong parity was detected. The re-transmission of the character is requested using the error signal during the guard time.
3:0	R/W	0	<b>TXRPT</b> TX Repeat This is a 4-bit register that specifies the number of attempts to re-transmit the character after the Smart Card signals the wrong parity during the guard time.

**8.8.6.7. Smart Card Reader Clock Divisor Register(Default Value: 0x00000000)**

Offset: 0x18			Register Name: <b>SCR_CLKDIV</b>
Bit	R/W	Default/Hex	Description
31:16	R/W	0	<b>BAUDDIV</b> Baud Clock Divisor. This 16-bit register defines the divisor value used to

			<p>generate the Baud Clock impulses from the system clock.</p> $BAUD = \frac{f_{sysclk}}{2 * (BAUDDIV + 1)}$
15:0	R/W	0	<p>SCCDIV Smart Card Clock Divisor. This 16-bit register defines the divisor value used to generate the Smart Card Clock from the system clock.</p> $f_{sclk} = \frac{f_{sysclk}}{2 * (SCCDIV + 1)}$ <p><math>f_{sclk}</math> is the frequency of Smart Card Clock Signal.</p> <p><math>f_{sysclk}</math> is the frequency of APB Clock.</p>

#### 8.8.6.8. Smart Card Reader Line Time Register(Default Value: 0x00000000)

Offset: 0x1C			Register Name: SCR_LTIM
Bit	R/W	Default/Hex	Description
31:24	/	/	/
23:16	R/W	0	<p>ATR ATR Start Limit. This 16-bit register defines the maximum time between the rising edge of the scrstn signal and the start of ATR response.</p> <p>ATR Start Limit = <math>128 * ATR * T_{sclk}</math>.</p>
15:8	R/W	0	<p>RST Reset Duration. This 16-bit register sets the duration of the Smart Card reset sequence. This value is same for the cold and warm reset.</p> <p>Cold/Warm Reset Duration = <math>128 * RST * T_{sclk}</math>.</p>
7:0	R/W	0	<p>ACT Activation/Deactivation Time. This 16-bit register sets the duration of each part of the activation and deactivation sequence.</p> <p>Activation/Deactivation Duration = <math>128 * ACT * T_{sclk}</math>.</p> $T_{sclk} = \frac{1}{f_{sclk}}$ <p><math>f_{sclk}</math> is the Smart Card Clock Cycle.</p>

#### 8.8.6.9. Smart Card Reader Character Time Register(Default Value: 0x00000000)

Offset: 0x20		Register Name: SCR_CTIM
--------------	--	-------------------------

Bit	R/W	Default/Hex	Description
31:16	R/W	0	CHARLIMIT Character Limit. This 16-bit register sets the maximum time between the leading edges of two consecutive characters. The value is ETUs.
15:8	/	/	/
7:0	R/W	0	GUARDTIME Character Guard time. This 8-bit register sets a delay at the end of each character transmitted from the Smart Card Reader to the Smart Card. The value is in ETUs. The parity error is besides signaled during the guard time.

#### 8.8.6.10. Smart Card Reader Line Control Register(Default Value: 0x00000000)

Offset: 0x30			Register Name: <b>SCR_PAD</b>
Bit	R/W	Default/Hex	Description
31:8	/	/	/
7	R/W	0	DSCVPPPP Direct Smart Card Vpp Pause/Prog. It provides direct access to SCVPPPP output.
6	R/W	0	DSCVPPEN Direct Smart Card Vpp Enable. It provides direct access to SCVPPEN output.
5	R/W	0	AUTOADEAVPP Automatic Vpp Handling. When high, it enables automatic handling of DSVPPEN and DSVPPPP signals during activation and deactivation sequence.
4	R/W	0	DSCVCC Direct Smart Card VCC. When DIRACCPADS='1', the DSCVCC bit provides direct access to SCVCC pad.
3	R/W	0	DSCRST Direct Smart Card Clock. When DIRACCPADS='1', the DSCRST bit provides direct access to SCRST pad.
2	R/W	0	DSCCLK Direct Smart Card Clock. When DIRACCPADS='1', the DSCCLK bit provides direct access to SCCLK pad.
1	R/W	0	DSCIO Direct Smart Card Input/Output. When DIRACCPADS='1', the DSCIO bit provides direct access to SCIO pad.
0	R/W	0	DIRACCPADS Direct Access to Smart Card Pads. When high, it disables a serial interface functionality and enables direct control of the smart card pads using following 4 bits.

**Note:** This register provides direct access to smart card pads without serial interface assistance. You can use this register feature with synchronous and any other non-ISO 7816 and non-EMV cards.

**8.8.6.11. Smart Card Reader FIFO Data Register(Default Value: 0x00000000)**

Offset: 0x0100			Register Name: <b>SCR_FIFO</b>
Bit	R/W	Default/Hex	Description
31:8	/	/	/
7:0	R/W	0	<b>FIFO_DATA</b> This 8-bit register provides access to the RX and TX FIFO buffers. The TX FIFO is accessed during the APB write transfer. The RX FIFO is accessed during the APB read transfer.

Confidential

## 8.9. EMAC

### 8.9.1. Overview

The Ethernet MAC(EMAC) controller enables a host to transmit and receive data over Ethernet in compliance with the IEEE 802.3-2002 standard. It supports 10M/100M/1000M external PHY with MII/ RGMII interface in both full and half duplex mode. The Ethernet MAC-DMA is designed for packet-oriented data transfers based on a linked list of descriptors. 4K Byte TXFIFO and 16K Byte RXFIFO are provided to keep continuous transmission and reception. Flow Control, CRC Pad & Stripping, and address filtering are also supported in this module.

The Ethernet MAC Controller includes the following features:

- Supports 10/100/1000Mbps data transfer rates
- Supports MII/RGMII PHY interface
- Supports both full-duplex and half-duplex operation
- Programmable frame length to support Standard or Jumbo Ethernet frames with sizes up to 16 KB
- Supports a variety of flexible address filtering modes
- Separate 32-bit status returned for transmission and reception packets
- Optimization for packet-oriented DMA transfers with frame delimiters
- Support linked-list (chained) descriptor chaining
- Descriptor architecture, allowing large blocks of data transfer with minimum CPU intervention; each descriptor can transfer up to 4 KB of data
- Comprehensive status reporting for normal operation and transfers with errors
- 4KB TXFIFO for transmission packets and 16KB RXFIFO for reception packets
- Programmable interrupt options for different operational conditions

### 8.9.2. Block Diagram

The EMAC Controller block diagram is shown below:

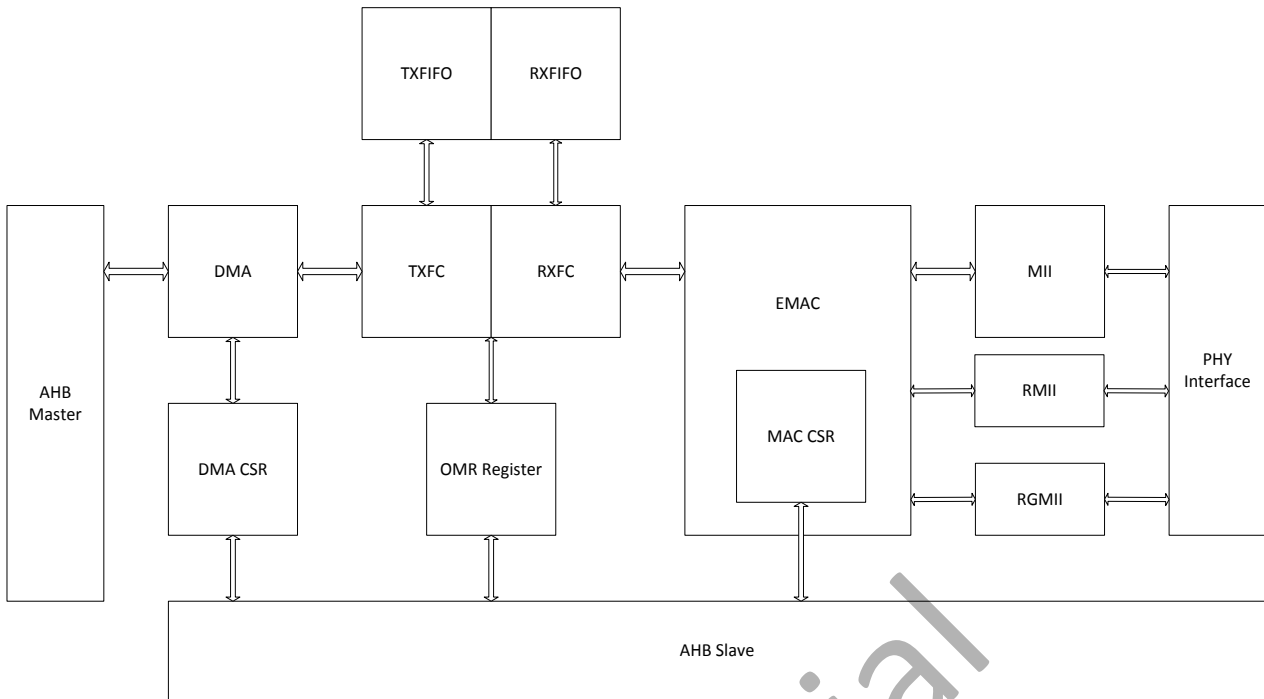

Figure 8-19. EMAC Block Diagram

### 8.9.3. EMAC Core Register List

Module Name	Base Address
EMAC	0x01C30000

Register Name	Offset	Description
BASIC_CTL_0	0x00	Basic Control 0 Register
BASIC_CTL_1	0x04	Basic Control 1 Register
INT_STA	0x08	Interrupt Status Register
INT_EN	0x0C	Interrupt Enable Register
TX_CTL_0	0x10	Transmit Control 0 Register
TX_CTL_1	0x14	Transmit Control 1 Register
TX_FLOW_CTL	0x1C	Transmit Flow Control Register
TX_DMA_DESC_LIST	0x20	Transmit Descriptor List Address Register
RX_CTL_0	0x24	Receive Control 0 Register
RX_CTL_1	0x28	Receive Control 1 Register
RX_DMA_DESC_LIST	0x34	Receive Descriptor List Address Register
RX_FRM_FLT	0x38	Receive Frame Filter Register
RX_HASH_0	0x40	Hash Table 0 Register
RX_HASH_1	0x44	Hash Table 1 Register

MII_CMD	0x48	Management Interface Command Register
MII_DATA	0x4C	Management Interface Data Register
ADDR_HIGH_0	0x50	MAC Address High Register 0
ADDR_LOW_0	0x54	MAC Address High Register 0
ADDR_HIGH_x	0x50+8*x	MAC Address High Register x(x:1~7)
ADDR_LOW_x	0x54+8*x	MAC Address Low Register x(x:1~7)
TX_DMA_STA	0xB0	Transmit DMA Status Register
TX_CUR_DESC	0xB4	Current Transmit Descriptor Register
TX_CUR_BUF	0xB8	Current Transmit Buffer Address Register
RX_DMA_STA	0xC0	Receive DMA Status Register
RX_CUR_DESC	0xC4	Current Receive Descriptor Register
RX_CUR_BUF	0xC8	Current Receive Buffer Address Register
RGMII_STA	0xD0	RGMII Status Register

### 8.9.4. EMAC Core Register Description

#### 8.9.4.1. Basic Control 0 Register(Default Value: 0x00000000)

Offset: 0x00			Register Name: <b>BASIC_CTL_0</b>
Bit	R/W	Default/Hex	Description
31:4	/	/	/
3:2	R/W	0	SPEED 00: 1000Mbps 11: 100Mbps 10: 10Mbps 01: Reserved
1	R/W	0	LOOPBACK 0: Disable; 1: Enable;
0	R/W	0	DUPLEX 0: Half-duplex 1: Full-duplex

#### 8.9.4.2. Basic Control 1 Register(Default Value: 0x08000000)

Offset: 0x04			Register Name: <b>BASIC_CTL_1</b>
Bit	R/W	Default/Hex	Description
31:30	/	/	/



29:24	R/W	8	BURST_LEN The burst length of RX and TX DMA transfer.
23:2	/	/	/
1	R/W	0	RX_TX_PRI 0: RX DMA and TX DMA have same priority 1: RX DMA has priority over TX DMA
0	R/W	0	SOFT_RST When this bit is set, soft reset all registers and logic. All clock inputs must be valid before soft rest. This bit is cleared internally when the reset operation is completed fully. Before write any register, this bit should read a 0.

#### 8.9.4.3. Interrupt Status Register(Default Value: 0x00000000)

Offset: 0x08			Register Name: INT_STA
Bit	R/W	Default/Hex	Description
31:17	/	/	/
16	R	0	RGMII_LINK_STA_INT When this bit is asserted, the link status of RGMII interface is changed.
15:14	/	/	/
13	R	0	RX_EARLY_INT When this bit asserted, the RX DMA had filled the first data buffer of the receive frame.
12	R	0	RX_OVERFLOW_INT When this bit is asserted, the RX FIFO had an overflow error.
11	R	0	RX_TIMEOUT_INT When this bit asserted, the length of receive frame is greater than 2048 bytes(10240 when JUMBO_FRM_EN is set)
10	R	0	RX_DMA_STOPPED_INT When this bit asserted, the RX DMA FSM is stopped.
9	R	0	RX_BUF_UA_INT When this asserted, the RX DMA can't acquire next RX descriptor and RX DMA FSM is suspended. The ownership of next RX descriptor should be changed to RX DMA. The RX DMA FSM will resume when write to DMA_RX_START bit or next receive frame is coming.
8	R	0	RX_INT When this bit is asserted, a frame reception is completed. The RX DMA FSM remains in the running state.
7:6	/	/	/
5	R	0	TX_EARLY_INT When this bit asserted , the frame is transmitted to FIFO totally.
4	R	0	TX_UNDERFLOW_INT When this bit is asserted, the TX FIFO had an underflow error.
3	R	0	TX_TIMEOUT_INT

			When this bit is asserted, the transmitter had been excessively active.
2	R	0	TX_BUF_UA_INT When this asserted, the TX DMA can not acquire next TX descriptor and TX DMA FSM is suspended. The ownership of next TX descriptor should be changed to TX DMA. The TX DMA FSM will resume when write to DMA_TX_START bit.
1	R	0	TX_DMA_STOPPED_INT When this bit is asserted, the TX DMA FSM is stopped.
0	R	0	TX_INT When this bit is asserted, a frame transmission is completed.

#### 8.9.4.4. Interrupt Enable Register(Default Value: 0x00000000)

Offset: 0x0C			Register Name: INT_EN
Bit	R/W	Default/Hex	Description
31:14	/	/	/
13	R/W	0	RX_EARLY_INT_EN 0: Disable early receive interrupt enable 1: Enable early receive interrupt enable
12	R/W	0	RX_OVERFLOW_INT_EN 0: Disable overflow interrupt 1: Enable overflow interrupt
11	R/W	0	RX_TIMEOUT_INT_EN 0: Disable receive timeout interrupt 1: Enable receive timeout interrupt
10	R/W	0	RX_DMA_STOPPED_INT_EN 0: Disable receive DMA FSM stopped interrupt 1: Enable receive DMA FSM stopped interrupt
9	R/W	0	RX_BUF_UA_INT_EN 0: Disable receive buffer unavailable interrupt 1: Enable receive buffer unavailable interrupt
8	R/W	0	RX_INT_EN 0: Disable receive interrupt 1: Enable receive interrupt
7:6			
5	R/W	0	TX_EARLY_INT_EN 0: Disable early transmit interrupt 1: Enable early transmit interrupt
4	R/W	0	TX_UNDERFLOW_INT_EN 0: Disable underflow interrupt 1: Enable underflow interrupt
3	R/W	0	TX_TIMEOUT_INT_EN 0: Disable transmit timeout interrupt

			1: Enable transmit timeout interrupt
2	R/W	0	TX_BUF_UA_INT_EN 0: Disable transmit buffer available interrupt 1: Enable transmit buffer available interrupt
1	R/W	0	TX_DMA_STOPPED_INT_EN 0: Disable transmit DMA FSM stopped interrupt 1: Enable transmit DMA FSM stopped interrupt
0	R/W	0	TX_INT_EN 0: Disable transmit interrupt 1: Enable transmit interrupt

#### 8.9.4.5. Transmit Control 0 Register(Default Value: 0x00000000)

Offset: 0x10			Register Name: <b>TX_CTL_0</b>
Bit	R/W	Default/Hex	Description
31	R/W	0	TX_EN Enable transmitter. 0: Disable transmitter after current transmission 1: Enable
30	R/W	0	TX_FRM_LEN_CTL 0: Allow to transmit frames no more than 2,048 bytes (10,240 if JUMBO_FRM_EN is set) and cut off any bytes after that 1: Allow to transmit frames of up to 16,384 bytes
29:0	/	/	/

#### 8.9.4.6. Transmit Control 1 Register(Default Value: 0x00000000)

Offset: 0x14			Register Name: <b>TX_CTL_1</b>
Bit	R/W	Default/Hex	Description
31	R/W	0	TX_DMA_START When set this bit, the TX DMA FSM will go no to work. It is cleared internally and always read a 0.
30	R/W	0	TX_DMA_EN 0: Stop TX DMA after the completion of current frame transmission. 1: Start and run TX DMA.
29:11	/	/	/
10:8	R/W	0	TX_TH The threshold value of TX DMA FIFO. When TX_MD is 0, transmission starts when the size of frame in TX DMA FIFO is greater than the threshold. In addition, full frames with a length less than the threshold are transferred automatically. 000: 64

			001: 128 010: 192 011: 256 Others: Reserved
7:2	/	/	/
1	R/W	0	TX_MD 0: Transmission starts after the number of data in TX DAM FIFO is greater than TX_TH 1: Transmission starts after a full frame located in TX DMA FIFO
0	R/W	0	FLUSH_TX_FIFO The functionality that flush the data in the TX FIFO. 0: Enable 1: Disable

**8.9.4.7. Transmit Flow Control Register(Default Value: 0x00000000)**

Offset: 0x1C			Register Name: TX_FLOW_CTL
Bit	R/W	Default/Hex	Description
31	R/W	0	TX_FLOW_CTL_STA This bit indicates a pause frame transmission is in progress. When the configuration of flow control is ready, set this bit to transmit a pause frame in full-duplex mode or activate the backpressure function. After completion of transmission, this bit will be cleared automatically. Before write register TX_FLOW_CTRL, this bit must be read as 0.
30:22	/	/	/
21:20	R/W	0	TX_PAUSE_FRM_SLOT The threshold of the pause timer at which the input flow control signal is checked for automatic retransmission of pause frame. The threshold values should be always less than the PAUSE_TIME
19:4	R/W	0	PAUSE_TIME The pause time field in the transmitted control frame.
3:2	/	/	/
1	R/W	0	ZQP_FRM_EN When set, enable the functionality to generate Zero-Quanta Pause control frame.
0	R/W	0	TX_FLOW_CTL_EN When set, enable flow control operation to transmit pause frames in full-duplex mode, or enable the back-pressure operation in half-duplex mode. 0: Disable 1: Enable

**8.9.4.8. Transmit DMA Descriptor List Address Register(Default Value: 0x00000000)**

Offset: 0x20			Register Name: <b>TX_DMA_LIST</b>
Bit	R/W	Default/Hex	Description
31:0	R/W	0	TX_DESC_LIST The base address of transmit descriptor list. It must be 32-bit aligned.

**8.9.4.9. Receive Control 0 Register(Default Value: 0x00000000)**

Offset: 0x24			Register Name: <b>RX_CTL_0</b>
Bit	R/W	Default/Hex	Description
31	R/W	0	RX_EN Enable receiver 0: Disable receiver after current reception 1: Enable
30	R/W	0	RX_FRM_LEN_CTL 0: Allow to receive frames less than or equal to 2,048 bytes (10,240 if JUMBO_FRM_EN is set) and cuts off any bytes received after that 1: Allow to receive frames of up to 16,384 bytes
29	R/W	0	JUMBO_FRM_EN When set, allows Jumbo frames of 9,018 bytes without reporting a giant frame error in the receive frame status.
28	R/W	0	STRIP_FCS When set, strip the Pad/FCS field on received frames only when the length's field value is less than or equal to 1,500 bytes.
27	R/W	0	CHECK_CRC When set, calculate CRC and check the IPv4 Header Checksum.
26:18	/	/	/
17	R/W	0	RX_PAUSE_FRM_MD 0: Only detect multicast pause frame specified in the 802.3x standard. 1: In addition to detect multicast pause frame specified in the 802.3x standard, also detect unicast pause frame with address specified in MAC Address 0 High Register and MAC address 0 Low Register.
16	R/W	0	RX_FLOW_CTL_EN When set, enable the functionality that decode the received pause frame and disable its transmitter for a specified time by pause frame.
15:0	/	/	/

**8.9.4.10. Receive Control 1 Register(Default Value: 0x00000000)**

Offset: 0x28			Register Name: <b>RX_CTL_1</b>
Bit	R/W	Default/Hex	Description

31	R/W	0	<b>RX_DMA_START</b> When set, the RX DMA will go no to work. It is cleared internally and always read a 0.
30	R/W	0	<b>RX_DMA_EN</b> 0: Stop RX DMA after finish receiving current frame 1: Start and run RX DMA
29:25	/	/	/
24	R/W	0	<b>RX_FIFO_FLOW_CTL</b> 0: Disable RX flow control 1: Enable RX flow control based on <b>RX_FLOW_CTL_TH_DEACT</b> and <b>RX_FLOW_CTL_TH_ACT</b>
23:22	R/W	0	<b>RX_FLOW_CTL_TH_DEACT</b> The threshold for deactivating flow control in both half-duplex mode and full-duplex mode 00: Full minus 1 KB 01: Full minus 2 KB 10: Full minus 3 KB 11: Full minus 4 KB
21:20	R/W	0	<b>RX_FLOW_CTL_TH_ACT</b> The threshold for activating flow control in both half-duplex mode and full-duplex mode. 00: Full minus 1 KB 01: Full minus 2 KB 10: Full minus 3 KB 11: Full minus 4 KB
19:6	/	/	/
5:4	R/W	0	<b>RX_TH</b> The threshold value of RX DMA FIFO. When <b>RX_MD</b> is 0, RX DMA starts to transfer data when the size of received frame in RX DMA FIFO is greater than the threshold. In addition, full frames with a length less than the threshold are transferred automatically. 00: 64 01: 32 10: 96 11: 128
3	R/W	0	<b>RX_ERR_FRM</b> 0: RX DMA drops frames with error 1: RX DMA forwards frames with error
2	R/W	0	<b>RX_RUNT_FRM</b> When set, forward undersized frames with no error and length less than 64bytes
1	R/W	0	<b>RX_MD</b> 0: RX DMA reads data from RX DMA FIFO to host memory after the number of data in RX DAM FIFO is greater than <b>RX_TH</b> 1: RX DMA reads data from RX DMA FIFO to host memory after a complete

			frame has been written to RX DMA FIFO
0	R/W	0	FLUSH_RX_FRM The functionality that flush the frames when receive descriptors/buffers is unavailable 0: Enable 1: Disable

**8.9.4.11. Receive DMA Descriptor List Address Register(Default Value: 0x00000000)**

Offset: 0x34			Register Name: <b>RX_DMA_LIST</b>
Bit	R/W	Default/Hex	Description
31:0	R/W	0	RX_DESC_LIST The base address of receive descriptor list. It must be 32-bit aligned.

**8.9.4.12. Receive Frame Filter Register(Default Value: 0x00000000)**

Offset: 0x38			Register Name: <b>RX_FRM_FLT</b>
Bit	R/W	Default/Hex	Description
31	R/W	0	DIS_ADDR_FILTER 0: Enable address filter 1: Disable address filter
30:18	/	/	/
17	R/W	0	DIS_BROADCAST 0: Receive all broadcast frames 1: Drop all broadcast frames
16	R/W	0	RX_ALL_MULTICAST 0: Filter multicast frame according to HASH_MULTICAST 1: Receive all multicast frames
15:14	/	/	/
13:12	R/W	0	CTL_FRM_FILTER 00, 01: Drop all control frames 10: Receive all control frames 11: Receive all control frames when pass the address filter
11:10	/	/	/
9	R/W	0	HASH_MULTICAST 0: Filter multicast frames by comparing the DA field with the values in DA MAC address registers 1: Filter multicast frames according to the hash table
8	R/W	0	HASH_UNICAST 0: Filter unicast frames by comparing the DA field with the values in DA MAC address registers 1: Filter unicast frames according to the hash table

7	/	/	/
6	R/W	0	SA_FILTER_EN 0: Receive frames and update the result of SA filter 1: Update the result of SA filter. In addition, if the SA field of received frame does not match the values in SA MAC address registers, drop this frame.
5	R/W	0	SA_INV_FILTER 0: When the SA field of current frame matches the values in SA MAC address registers, it passes the SA filter 1: When the SA field of current frame does not match the values in SA MAC address registers,, it passes the SA filter
4	R/W	0	DA_INV_FILTER 0: Normal filtering of frames is performed 1: Filter both unicast and multicast frames by comparing DA field in inverse filtering mode
3:2	/	/	/
1	R/W	0	FLT_MD 0: If the HASH_MULTICAST or HASH_UNICAST is set, the frame is passed only when it matches the Hash filter 1: Receive the frame when it pass the address register filter or the hash filter(set by HASH_MULTICAST or HASH_UNICAST)
0	R/W	0	RX_ALL 0: Receive the frames that pass the SA/DA address filter 1: Receive all frames and update the result of address filter(pass or fail) in the receive status word

**8.9.4.13. Receive Hash Table 0 Register(Default Value: 0x00000000)**

Offset: 0x40			Register Name: <b>RX_HASH_0</b>
Bit	R/W	Default/Hex	Description
31:0	R/W	0	HASH_TAB_0 The upper 32 bits of Hash table for receive frame filter.

**8.9.4.14. Receive Hash Table 1 Register(Default Value: 0x00000000)**

Offset: 0x44			Register Name: <b>RX_HASH_1</b>
Bit	R/W	Default/Hex	Description
31:0	R/W	0	HASH_TAB_1 The lower 32 bits of Hash table for receive frame filter.



**8.9.4.15. MII Command Register(Default Value: 0x00000000)**

Offset: 0x48			Register Name: <b>MII_CMD</b>
Bit	R/W	Default/Hex	Description
31:23	/	/	/
22:20	R/W	0	MDC_DIV_RATIO_M MDC clock divide ration(m). The source of MDC clock is AHB clock. 000: 16 001: 32 010: 64 011: 128 Others: Reserved
19:17	/	/	/
16:12	R/W	0	PHY_ADDR Select a PHY device from 32 possible candidates.
11:9	/	/	/
8:4	R/W	0	PHY_REG_ADDR Select register in the selected PHY device
3:2	/	/	/
1	R/W	0	MII_WR 0: Read register in selected PHY and return data in EMAC_GMII_DATA 1: Write register in selected PHY using data in EMAC_GMII_DATA
0	R/W	0	MII_BUSY This bit indicates that a read or write operation is in progress. When prepared the data and register address for a write operation or the register address for a read operation, set this bit and start to access register in PHY. When this bit is cleared automatically, the read or write operation is over and the data in EMAC_GMII_DATA is valid for a read operation.

**8.9.4.16. MII Data Register(Default Value: 0x00000000)**

Offset: 0x4C			Register Name: <b>MII_DATA</b>
Bit	R/W	Default/Hex	Description
31:16	/	/	/
15:0	R/W	0	MII_DATA The 16-bit data to be written to or read from the register in the selected PHY.

**8.9.4.17. MAC Address 0 High Register(Default Value: 0x0000FFFF)**

Offset: 0x50			Register Name: <b>ADDR0_HIGH</b>
Bit	R/W	Default/Hex	Description
31:16	/	/	/

15:0	R/W	0xFFFF	MAC_ADDR_0_HIGH The upper 16bits of the 1 <sup>st</sup> MAC address.
------	-----	--------	---

#### 8.9.4.18. MAC Address 0 Low Register(Default Value: 0xFFFFFFFF)

Offset: 0x54			Register Name: <b>ADDR0_LOW</b>
Bit	R/W	Default/Hex	Description
31:0	R/W	0xFFFFFFFF	MAC_ADDR_0_LOW The lower 32bits of 1 <sup>st</sup> MAC address.

#### 8.9.4.19. MAC Address x High Register(Default Value: 0x0000FFFF)

Offset: 0x50+8*x (x=1~7)			Register Name: <b>ADDRx_HIGH</b>
Bit	R/W	Default/Hex	Description
31	R/W	0	MAC_ADDR_CTL 0: MAC address x(x: 1~7) is not valid, and it will be ignored by the address filter 1: MAC address x(x: 1~7) is valid
30	R/W	0.	MAC_ADDR_TYPE 1: MAC address x(x:1~7) used to compare with the source address of the received frame 0: MAC address x(x:1~7) used to compare with the destination address of the received frame
29:24	R/W	0	MAC_ADDR_BYTE_CTL MAC address byte control mask. The lower bit of mask controls the lower byte of in MAC address x(x:1~7). When the bit of mask is 1, do not compare the corresponding byte.
23:16	/	/	/
15:0	R/W	0xFFFF	MAC_ADDR_x_HIGH The upper 16bits of the MAC address x(x:1~7).

#### 8.9.4.20. MAC Address x Low Register(Default Value: 0xFFFFFFFF)

Offset: 0x54+8*x (x=1~7)			Register Name: <b>ADDRx_LOW</b>
Bit	R/W	Default/Hex	Description
31:0	R/W	0xFFFFFFFF	MAC_ADDR_x_LOW The lower 32bits of MAC address x(x:1~7).

**8.9.4.21. Transmit DMA Status Register(Default Value: 0x00000000)**

Offset: 0xB0			Register Name: <b>TX_DMA_STA</b>
Bit	R/W	Default/Hex	Description
31:3	/	/	/
2:0	R	0	TX_DMA_STA The state of Transmit DMA FSM. 000: STOP: When reset or disable TX DMA; 001: RUN_FETCH_DESC: Fetching TX DMA descriptor; 010: RUN_WAIT_STA: Waiting for the status of TX frame; 011: RUN_TRANS_DATA: Passing frame from host memory to TX DMA FIFO; 111: RUN_CLOSE_DESC: Closing TX descriptor. 110: SUSPEND: TX descriptor unavailable or TX DMA FIFO underflow; 100, 101: Reserved;

**8.9.4.22. Transmit DMA Current Descriptor Register(Default Value: 0x00000000)**

Offset: 0xB4			Register Name: <b>TX_DMA_CUR_DESC</b>
Bit	R/W	Default/Hex	Description
31:0	R	0	The address of current transmit descriptor.

**8.9.4.23. Transmit DMA Current Buffer Address Register(Default Value: 0x00000000)**

Offset: 0xB8			Register Name: <b>TX_DMA_CUR_BUF</b>
Bit	R/W	Default/Hex	Description
31:0	R	0	The address of current transmit DMA buffer

**8.9.4.24. Receive DMA Status Register(Default Value: 0x00000000)**

Offset: 0xC0			Register Name: <b>RX_DMA_STA</b>
Bit	R/W	Default/Hex	Description
31:3	/	/	/
2:0	R	0	RX_DMA_STA The state of RX DMA FSM. 000: STOP: When reset or disable RX DMA; 001: RUN_FETCH_DESC: Fetching RX DMA descriptor; 011: RUN_WAIT_FRM: Waiting for frame. 100: SUSPEND: RX descriptor unavailable; 101: RUN_CLOSE_DESC: Closing RX descriptor. 111: RUN_TRANS_DATA: Passing frame from host memory to RX DMA FIFO;

			010, 110: Reserved.
--	--	--	---------------------

**8.9.4.25. Receive DMA Current Descriptor Register(Default Value: 0x00000000)**

Offset: 0xC4			Register Name: <b>RX_DMA_CUR_DESC</b>
Bit	R/W	Default/Hex	Description
31:0	R	0	The address of current receive descriptor

**8.9.4.26. Receive DMA Current Buffer Address Register(Default Value: 0x00000000)**

Offset: 0xC8			Register Name: <b>RX_DMA_CUR_BUF</b>
Bit	R/W	Default/Hex	Description
31:0	R	0	The address of current receive DMA buffer

**8.9.4.27. RGMII Status Register(Default Value: 0x00000000)**

Offset: 0xD0			Register Name: <b>RGMII_STA</b>
Bit	R/W	Default/Hex	Description
31:4	/	/	/
3	R	0	RGMII_LINK The link status of RGMII interface 0: down 1: up
2:1	R	0	RGMII_LINK_SPD The link speed of RGMII interface 00: 2.5 MHz 01: 25 MHz 10: 125 MHz
0	R	0	RGMII_LINK_MD The link Mode of RGMII interface 0: Half-Duplex 1: Full-Duplex

**8.9.5. EMAC RX/TX Descriptor**

The EMAC' internal DMA transfers data between host memory and internal RX/TX FIFO with a linked list of descriptors. Each descriptor is consisted of four words, and contains some necessary information to transfer TX and RX frames. The descriptor list structure is shown in figure 8-20. The address of each descriptor must be 32-bit aligned.

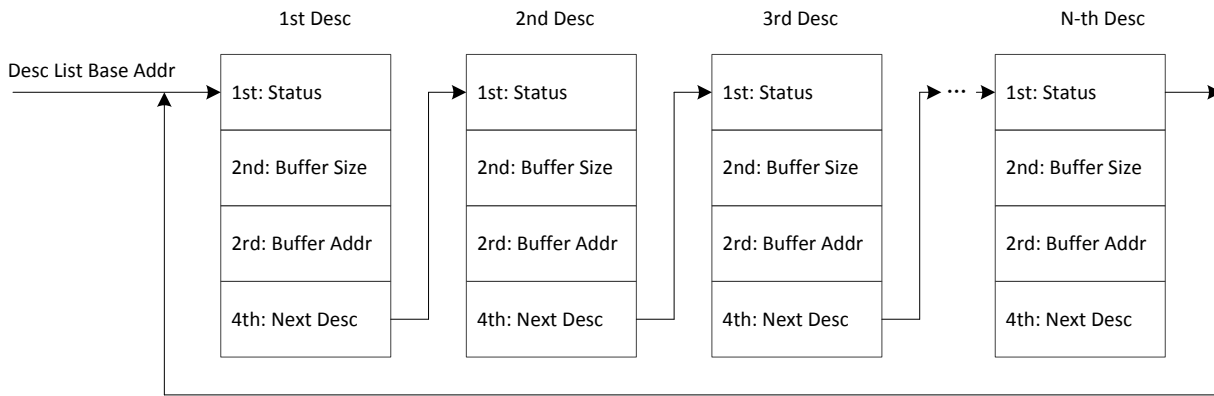

Figure 8-20. EMAC RX/TX Descriptor List

**8.9.5.1. Transmit Descriptor**

**1st Word of Transmit Descriptor**

Bits	Description
31	TX_DESC_CTL When set, current descriptor can be used by DMA. This bit is cleared by DMA when the whole frame is transmitted or all data in current descriptor's buffer are transmitted.
30:17	Reserved
16	TX_HEADER_ERR When set, the checksum of transmitted frame's header is wrong.
15	Reserved
14	TX_LENGTH_ERR When set, the length of transmitted frame is wrong.
13	Reserved
12	TX_PAYLOAD_ERR When set, the checksum of transmitted frame's payload is wrong.
11	Reserved
10	TX_CRD_ERR When set, carrier is lost during transmission.
9	TX_COL_ERR_0 When set, the frame is aborted because of collision after contention period.
8	TX_COL_ERR_1 When set, the frame is aborted because of too many collisions.
7	Reserved.
6:3	TX_COL_CNT The number of collisions before transmission.
2	TX_DEFER_ERR When set, the frame is aborted because of too much deferral.
1	TX_UNDERFLOW_ERR

	When set, the frame is aborted because of TX FIFO underflow error.
0	TX_DEFER When set in Half-Duplex mode, the EMAC defers the frame transmission.

### 2nd Word of Transmit Descriptor

Bits	Description
31	TX_INT_CTL When set and the current frame have been transmitted, the TX_INT in Interrupt Status Register will be set.
30	LAST_DESC When set, current descriptor is the last one for current frame.
29	FIR_DESC When set, current descriptor is the first one for current frame.
28:27	CHECKSUM_CTL These bits control to insert checksums in transmit frame.
26	CRC_CTL When set, CRC field is not transmitted.
25:11	Reserved
10:0	BUF_SIZE The size of buffer specified by current descriptor.

### 3rd Word of Transmit Descriptor

Bits	Description
31:0	BUF_ADDR The address of buffer specified by current descriptor.

### 4th Word of Transmit Descriptor

Bits	Description
31:0	NEXT_DESC_ADDR The address of next descriptor. It must be 32-bit aligned.

## 8.9.5.2. Receive Descriptor

### 1st Word of Receive Descriptor

Bits	Description
31	RX_DESC_CTL When set, current descriptor can be used by DMA. This bit is cleared by DMA when complete frame is

	received or current descriptor's buffer is full.
30	RX_DAF_FAIL When set, current frame don't pass DA filter.
29:16	RX_FRM_LEN When LAST_DESC is not set and no error bit is set, this field is the length of received data for current frame. When LAST_DESC is set, RX_OVERFLOW_ERR and RX_NO_ENOUGH_BUF_ERR are not set, this field is the length of receive frame.
15	Reserved
14	RX_NO_ENOUGH_BUF_ERR When set, current frame is clipped because of no enough buffer.
13	RX_SAF_FAIL When set, current fame don't pass SA filter.
12	Reserved.
11	RX_OVERFLOW_ERR When set, a buffer overflow error occurred and current frame is wrong.
10	Reserved
9	FIR_DESC When set, current descriptor is the first descriptor for current frame.
8	LAST_DESC When set, current descriptor is the last descriptor for current frame.
7	RX_HEADER_ERR When set, the checksum of frame's header is wrong.
6	RX_COL_ERR When set, there is a late collision during reception in half-duplex mode.
5	Reserved.
4	RX_LENGTH_ERR When set, the length of current frame is wrong.
3	RX_PHY_ERR When set, the receive error signal from PHY is asserted during reception.
2	Reserved.
1	RX_CRC_ERR When set, the CRC filed of received frame is wrong.
0	RX_PAYLOAD_ERR When set, the checksum or length of received frame's payload is wrong.

### 2nd Word of Receive Descriptor

Bits	Description
31	RX_INT_CTL When set and a frame have been received, the RX_INT will not be set.
30:11	Reserved
10:0	BUF_SIZE The size of buffer specified by current descriptor.

**3rd Word of Receive Descriptor**

Bits	Description
31:0	BUF_ADDR The address of buffer specified by current descriptor.

**4th Word of Receive Descriptor**

Bits	Description
31:0	NEXT_DESC_ADDR The address of next descriptor. This field must be 32-bit aligned.

Confidential



## 8.10. TSC

### 8.10.1. Overview

The transport stream controller(TSC) is responsible for de-multiplexing and pre-processing the inputting multimedia data defined in ISO/IEC 13818-1.

The transport stream controller receives multimedia data stream from SSI (Synchronous Serial Port)/SPI (Synchronous Parallel Port) inputs and de-multiplexing the data into Packets by PID (Packet Identify). Before the Packet to be store to memory by DMA, it can be pre-processing by the Transport Stream Descrambler.

The transport stream controller can be used for almost all multi-media application cases, example: DVB Set top Box, IPTV, Streaming-media Box, multi-media players and so on.

The Transport Stream Controller (TSC) includes the following features:

- Supports industry-standard AMBA Host Bus (AHB) and it is fully compliant with the AMBA Specification, Revision 2.0. Supports 32-bit Little Endian bus.
- Supports AHB 32-bit bus width
- One external Synchronous Parallel Interface (SPI) or one external Synchronous Serial Interface (SSI)
- 32 channels PID filter
- Multiple transport stream packet (188, 192, 204) format support
- SPI and SSI timing parameters are configurable
- Hardware packet synchronous byte error detecting
- Hardware PCR packet detecting
- Configurable SPI transport stream generator for streams in DRAM memory
- DMA is supported for transferring data
- Interrupt is supported
- Support DVB-CSA V1.1 Descrambler

The Top Diagram of TSC is below:

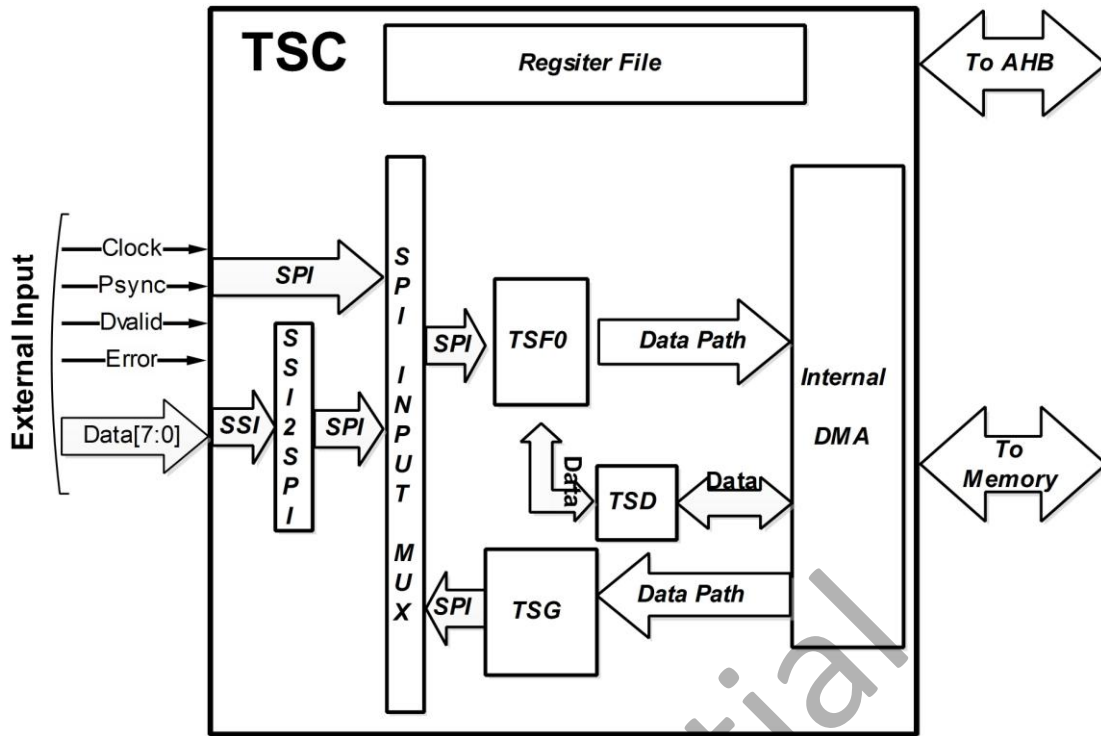

Figure 8-21. TSC Block Diagram

**Note:**

- TSC – TS Controller
- TSF – TS Filter
- TSD – TS Descrambler
- TSG – TS Generator

**8.10.2. Transport Stream Input Timing Diagram**

Table 8-1. Input Signals Description

Name	Description
Clock	Clock of SPI/SSI data input
Psync	Packet sync (or Start flag) for TS packet
Dvalid	Data valid flag for TS data input
Error	Error flag for TS data, but do not used by TSC
Data[7:0]	TS data input. Data[7:0] are used in SPI mode; Only Data[0] is used in SSI mode.

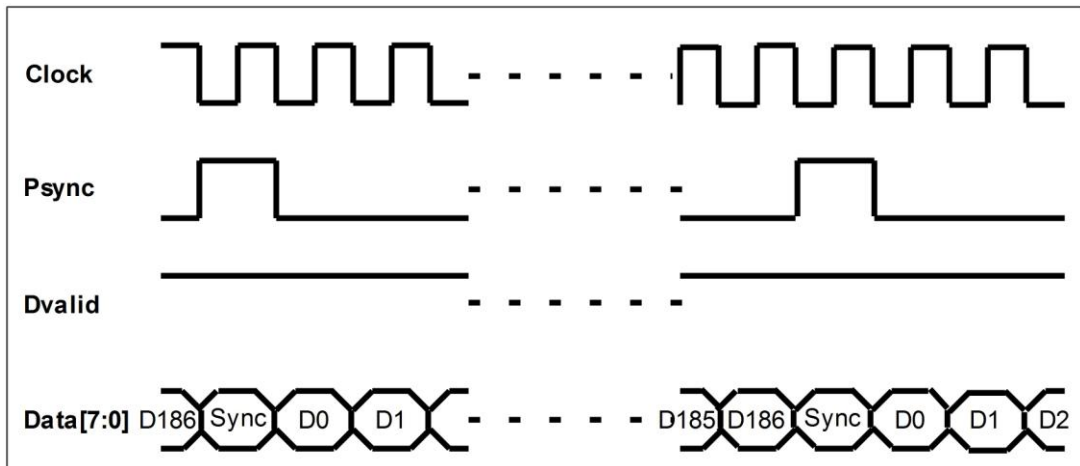

Figure 8-22. Input Timing for SPI mode  
(CLOCK = Rising Edge, PSYNC = High Active, DVALID = High Active, Packet Size = 188 Bytes)

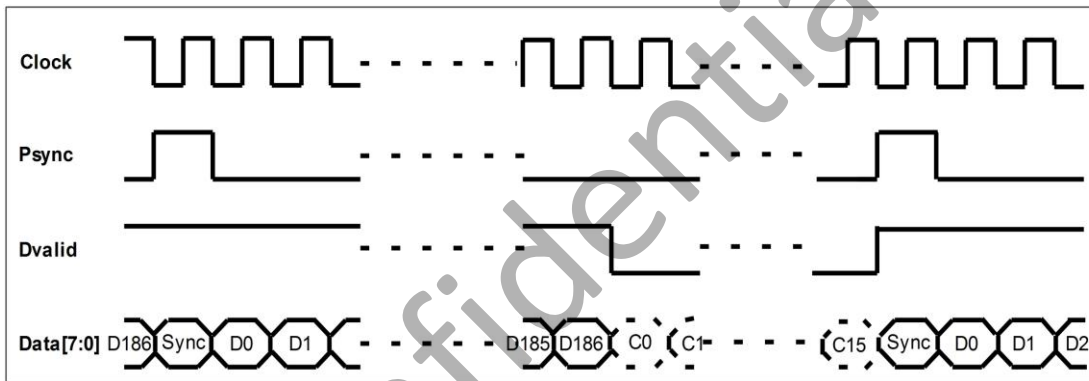

Figure 8-23. Alternative Input Timing for SPI mode  
(CLOCK = Rising Edge, PSYNC = High Active, DVALID = High Active, Packet Size = 188 Bytes)

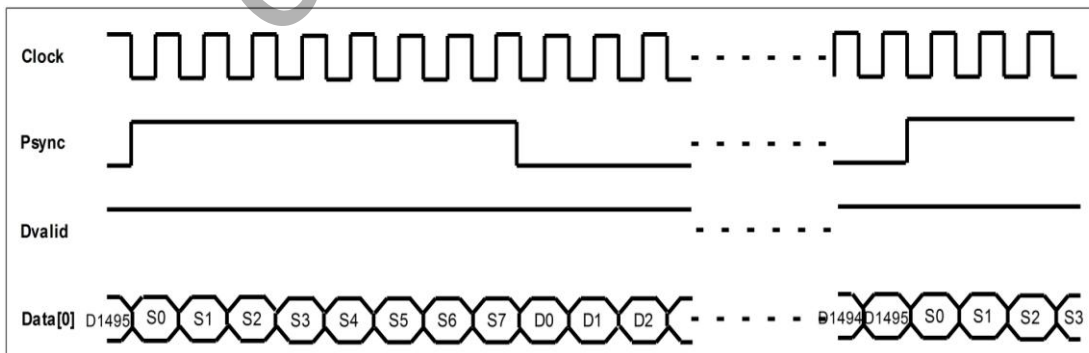

Figure 8-24. Alternative Input Timing for SSI mode  
(CLOCK = Rising Edge, PSYNC = High Active, DVALID = High Active, Packet Size = 188 Bytes)

### 8.10.3. Transport Stream Controller Register List

Module Name	Base Address
TSC	0x01C06000
TSG OFFSET	0x00000040
TSF0 OFFSET	0x00000080
TSF1 OFFSET	0x00000100
TSF2 OFFSET	0x00000180

Register Name	Offset	Description
TSC_CTLR	TSC + 0x00	TSC Control Register
TSC_STAR	TSC + 0x04	TSC Status Register
TSC_PCTLR	TSC + 0x10	TSC Port Control Register
TSC_PPARR	TSC + 0x14	TSC Port Parameter Register
TSC_TSFMUXR	TSC + 0x20	TSC TSF Input Multiplex Control Register
TSC_OUTMUXR	TSC + 0x28	TSC Port Output Multiplex Control Register
TSG_CTLR	TSG + 0x00	TSG Control Register
TSG_PPR	TSG + 0x04	TSG Packet Parameter Register
TSG_STAR	TSG + 0x08	TSG Status Register
TSG_CCR	TSG + 0x0c	TSG Clock Control Register
TSG_BBAR	TSG + 0x10	TSG Buffer Base Address Register
TSG_BSZR	TSG + 0x14	TSG Buffer Size Register
TSG_BPR	TSG + 0x18	TSG Buffer Pointer Register
TSF_CTLR	TSF + 0x00	TSF Control Register
TSF_PPR	TSF + 0x04	TSF Packet Parameter Register
TSF_STAR	TSF + 0x08	TSF Status Register
TSF_DIER	TSF + 0x10	TSF DMA Interrupt Enable Register
TSF_OIER	TSF + 0x14	TSF Overlap Interrupt Enable Register
TSF_DISR	TSF + 0x18	TSF DMA Interrupt Status Register
TSF_OISR	TSF + 0x1c	TSF Overlap Interrupt Status Register
TSF_PCRCR	TSF + 0x20	TSF PCR Control Register
TSF_PCRDR	TSF + 0x24	TSF PCR Data Register
TSF_CENR	TSF + 0x30	TSF Channel Enable Register
TSF_CPER	TSF + 0x34	TSF Channel PES Enable Register
TSF_CDERR	TSF + 0x38	TSF Channel Descramble Enable Register
TSF_CINDR	TSF + 0x3c	TSF Channel Index Register
TSF_CCTLR	TSF + 0x40	TSF Channel Control Register
TSF_CSTAR	TSF + 0x44	TSF Channel Status Register
TSF_CCWIR	TSF + 0x48	TSF Channel CW Index Register
TSF_CPIDR	TSF + 0x4c	TSF Channel PID Register
TSF_CBBAR	TSF + 0x50	TSF Channel Buffer Base Address Register
TSF_CBSZR	TSF + 0x54	TSF Channel Buffer Size Register

TSF_CBWPR	TSF + 0x58	TSF Channel Buffer Write Pointer Register
TSF_CBRPR	TSF + 0x5c	TSF Channel Buffer Read Pointer Register
TSD_CTLR	TSD + 0x00	TSD Control Register
TSD_STAR	TSD + 0x04	TSD Status Register
TSD_CWIR	TSD + 0x1c	TSD Control Word Index Register
TSD_CWR	TSD + 0x20	TSD Control Word Register

### 8.10.4. Transport Stream Controller Register Description

#### 8.10.4.1. TSC Control Register(Default Value: 0x00000000)

Offset: 0x00			Register Name: <b>TSC_CTLR</b>
Bit	R/W	Default/Hex	Description
31:0	/	/	/

#### 8.10.4.2. TSC Status Register(Default Value: 0x00000000)

Offset: 0x04			Register Name: <b>TSC_STAR</b>
Bit	R/W	Default/Hex	Description
31:0	/	/	/

#### 8.10.4.3. TSC Port Control Register(Default Value: 0x00000000)

Offset: 0x10			Register Name: <b>TSC_PCTLR</b>
Bit	R/W	Default/Hex	Description
31:1	/	/	/
0	R/W	0	TSInPort0Ctrl TS Input Port0 Control 0 – SPI 1 – SSI

#### 8.10.4.4. TSC Port Parameter Register(Default Value: 0x00000000)

Offset: 0x14			Register Name: <b>TSC_PPARR</b>
Bit	R/W	Default/Hex	Description
31:8	/	/	/
7:0	R/W	0x00	TSInPort0Par

			TS Input Port0 Parameters														
			<table border="1"> <thead> <tr> <th>Bit</th> <th>Definition</th> </tr> </thead> <tbody> <tr> <td>7:5</td> <td>Reserved</td> </tr> <tr> <td>4</td> <td>SSI data order 0: MSB first for one byte data 1: LSB first for one byte data</td> </tr> <tr> <td>3</td> <td>CLOCK signal polarity 0 : Rise edge capturing 1: Fall edge capturing</td> </tr> <tr> <td>2</td> <td>ERROR signal polarity 0: High level active 1: Low level active</td> </tr> <tr> <td>1</td> <td>DVALID signal polarity 0: High level active 1: Low level active</td> </tr> <tr> <td>0</td> <td>PSYNC signal polarity 0: High level active 1: Low level active</td> </tr> </tbody> </table>	Bit	Definition	7:5	Reserved	4	SSI data order 0: MSB first for one byte data 1: LSB first for one byte data	3	CLOCK signal polarity 0 : Rise edge capturing 1: Fall edge capturing	2	ERROR signal polarity 0: High level active 1: Low level active	1	DVALID signal polarity 0: High level active 1: Low level active	0	PSYNC signal polarity 0: High level active 1: Low level active
Bit	Definition																
7:5	Reserved																
4	SSI data order 0: MSB first for one byte data 1: LSB first for one byte data																
3	CLOCK signal polarity 0 : Rise edge capturing 1: Fall edge capturing																
2	ERROR signal polarity 0: High level active 1: Low level active																
1	DVALID signal polarity 0: High level active 1: Low level active																
0	PSYNC signal polarity 0: High level active 1: Low level active																

**8.10.4.5. TSC TSF Input Multiplex Control Register(Default Value: 0x00000000)**

Offset: 0x20			Register Name: <b>TSC_TSFMUXR</b>
Bit	R/W	Default/Hex	Description
31:4	/	/	/
3:0	R/W	0x0	TSF0InputMuxCtrl TSF0 Input Multiplex Control 0x0 –Data from TSG 0x1 –Data from TS IN Port0 Others – Reserved

**8.10.4.6. TSC Port Output Multiplex Control Register(Default Value: 0x00000000)**

Offset: 0x28			Register Name: <b>TSC_TSFMUXR</b>
Bit	R/W	Default/Hex	Description
31:0	/	/	/

**8.10.4.7. TSC Port Output Multiplex Control Register(Default Value: 0x00000000)**

Offset: TSG+0x00			Register Name: <b>TSC_TSFMUXR</b>
Bit	R/W	Default/Hex	Description

31:26	/	/	/
			<p>TSGSts Status for TS Generator 0: IDLE state 1: Running state 2: PAUSE state Others: Reserved</p>
25:24	R	0	
23:10	/	/	/
			<p>TSGLBufMode Loop Buffer Mode When set to '1', the TSG external buffer is in loop mode.</p>
9	R/W	0	
			<p>TSGSyncByteChkEn Sync Byte Check Enable Enable/ Disable check SYNC byte fro receiving new packet 0: Disable 1: Enable If enable check SYNC byte and an error SYNC byte is receiver, TS Generator would come into PAUSE state. If the correspond interrupt is enable, the interrupt would happen.</p>
8	R/W	0	
7:3	/	/	/
			<p>TSGPauseBit Pause Bit for TS Generator Write '1' to pause TS Generator. TS Generator would stop fetch new data from DRAM. After finishing this operation, this bit will clear to zero by hardware. In PAUSE state, write '1' to resume this state.</p>
2	R/W	0	
			<p>TSGStopBit Stop Bit for TS Generator Write '1' to stop TS Generator. TS Generator would stop fetch new data from DRAM. The data already in its FIFO should be sent to TS filter. After finishing this operation, this bit will clear to zero by hardware.</p>
1	R/W	0	
			<p>TSGStartBit Start Bit for TS Generator Write '1' to start TS Generator. TS Generator would fetch data from DRAM and generate SPI stream to TS filter. This bit will clear to zero by hardware after TS Generator is running.</p>
0	R/W	0	

#### 8.10.4.8. TSG Packet Parameter Register(Default Value: 0x00470000)

Offset: TSG+0x04			Register Name: <b>TSG_PPR</b>
Bit	R/W	Default/Hex	Description
31:24	/	/	/
			<p>SyncByteVal Sync Byte Value This is the value of sync byte used in the TS Packet.</p>
23:16	R/W	0x47	

15:8	/	/	/
7	R/W	0	SyncBytePos Sync Byte Position 0: the 1st byte position 1: the 5th byte position Notes: This bit is only used for 192 bytes packet size.
6:2	/	/	/
1:0	R/W	0	PktSize Packet Size Byte Size for one TS packet 0: 188 bytes Others: Reserved

**8.10.4.9. TSG Interrupt Enable and Status Register(Default Value: 0x00000000)**

Offset: TSG+0x08			Register Name: <b>TSG_IESR</b>
Bit	R/W	Default/Hex	Description
31:20	/	/	/
19	R/W	0	TSGEndIE TS Generator (TSG) End Interrupt Enable 0: Disable 1: Enable If set this bit, the interrupt would assert to CPU when all data in external DRAM are sent to TS PID filter.
18	R/W	0	TSGFFIE TS Generator (TSG) Full Finish Interrupt Enable 0: Disable 1: Enable
17	R/W	0	TSGHFIE TS Generator (TSG) Half Finish Interrupt Enable 0: Disable 1: Enable
16	R/W	0	TSGErrSyncByteIE TS Generator (TSG) Error Sync Byte Interrupt Enable 0: Disable 1: Enable
15:4	/	/	/
3	R/W	0	TSGEndSts TS Generator (TSG) End Status Write '1' to clear.
2	R/W	0	TSGFFSts TS Generator (TSG) Full Finish Status Write '1' to clear.
1	R/W	0	TSGHFSts



			TS Generator (TSG) Half Finish Status Write '1' to clear.
0	R/W	0	TSGErrSyncByteSts TS Generator (TSG) Error Sync Byte Status Write '1' to clear.

**8.10.4.10. TSG Clock Control Register(Default Value: 0x00000000)**

Offset: TSG+0x0C			Register Name: <b>TSG_CCR</b>
Bit	R/W	Default/Hex	Description
31:16	R/W	0x0	TSGCDF_N TSG Clock Divide Factor (N) The Numerator part of TSG Clock Divisor Factor.
15:0	R/W	0x0	TSGCDF_D TSG Clock Divide Factor (D) The Denominator part of TSG Clock Divisor Factor. Frequency of output clock: $F_o = (F_i * (N+1)) / (8 * (D+1))$ . $F_i$ is the input special clock of TSC, and D must not less than N.

**8.10.4.11. TSG Buffer Base Address Register(Default Value: 0x00000000)**

Offset: TSG+0x10			Register Name: <b>TSG_BBAR</b>
Bit	R/W	Default/Hex	Description
31:28	/	/	/
27:0	RW	0x0	TSGBufBase Buffer Base Address This value is a start address of TSG buffer. Note: This value should be 4-word (16Bytes) align, and the lowest 4-bit of this value should be zero.

**8.10.4.12. TSG Buffer Size Register(Default Value: 0x00000000)**

Offset: TSG+0x14			Register Name: <b>TSG_BSZR</b>
Bit	R/W	Default/Hex	Description
31:24	/	/	/
23:0	R/W	0	TSGBufSize Data Buffer Size for TS Generator It is in byte unit. The size should be 4-word (16Bytes) align, and the lowest 4 bits should be zero.

**8.10.4.13. TSG Buffer Point Register(Default Value: 0x00000000)**

Offset: TSG+0x18			Register Name: <b>TSG_BPR</b>
Bit	R/W	Default/Hex	Description
31:24	/	/	/
23:0	R	0	TSGBufPtr Data Buffer Pointer for TS Generator Current TS generator data buffer read pointer (in byte unit)

**8.10.4.14. TSF Control and Status Register(Default Value: 0x00000000)**

Offset: TSF+0x00			Register Name: <b>TSF_CSR</b>
Bit	R/W	Default/Hex	Description
31:3	/	/	/
2	R/W	0	TSF Enable 0: Disable TSF Input 1: Enable TSF Input
1	/	/	/
0			TSFGSR TSF Global Soft Reset A software writing '1' will reset all status and state machine of TSF. And it's cleared by hardware after finish reset. A software writing '0' has no effect.

**8.10.4.15. TSF Packet Parameter Register(Default Value: 0x00470000)**

Offset: TSF+0x04			Register Name: <b>TSF_PPR</b>
Bit	R/W	Default/Hex	Description
31:28	R/W	0	LostSyncThd Lost Sync Packet Threshold It is used for packet sync lost by checking the value of sync byte.
27:24	R/W	0	SyncThd Sync Packet Threshold It is used for packet sync by checking the value of sync byte.
23:16	R/W	0x47	SyncByteVal Sync Byte Value This is the value of sync byte used in the TS Packet.
15:10	/	/	/
9:8	R/W	0	SyncMthd Packet Sync Method 0: By PSYNC signal 1: By sync byte

			2: By both PSYNC and Sync Byte 3: Reserved
7	R/W	0	SyncBytePos Sync Byte Position 0: the 1st byte position 1: the 5th byte position Notes: This bit is only used for 192 bytes packet size.
6:2	/	/	/
1:0	R/W	0	PktSize Packet Size Byte Size for one TS packet 0: 188 bytes 1: 192 bytes 2: 204 bytes 3: Reserved

**8.10.4.16. TSF Interrupt Enable and Status Register(Default Value: 0x00000000)**

Offset: TSF+0x08			Register Name: <b>TSF_IESR</b>
Bit	R/W	Default/Hex	Description
31:20	/	/	/
19	R/W	0	TSFFOIE TS PID Filter (TSF) Internal FIFO Overrun Interrupt Enable 0: Disable 1: Enable
18	R/W	0	TSFPPDIE TS PCR Packet Detect Interrupt Enable 0: Disable 1: Enable
17	R/W	0	TSFCOIE TS PID Filter (TSF) Channel Overlap Interrupt Global Enable 0: Disable 1: Enable
16	R/W	0	TSFCDIE TS PID Filter (TSF) Channel DMA Interrupt Global Enable 0: Disable 1: Enable
15:4	/	/	/
3	R/W	0	TSFFOIS TS PID Filter (TSF) Internal FIFO Overrun Status Write '1' to clear.
2	R/W	0	TSFPPDIS TS PCR Packet Found Status When it is '1', one TS PCR Packet is found. Write '1' to clear.

1	R	0	TSFCOIS TS PID Filter (TSF) Channel Overlap Status It is global status for 16 channel. It would clear to zero after all channels status bits are clear.
0	R	0	TSFCDIS TS PID Filter (TSF) Channel DMA status It is global status for 16 channel. It would clear to zero after all channels status bits are clear.

**8.10.4.17. TSF DMA Interrupt Enable Register(Default Value: 0x00000000)**

Offset: TSF+0x10			Register Name: <b>TSF_DIER</b>
Bit	R/W	Default/Hex	Description
31:0	R/W	0x0	DMAIE DMA Interrupt Enable DMA interrupt enable bits for channel 0~31.

**8.10.4.18. TSF Overlap Interrupt Enable Register(Default Value: 0x00000000)**

Offset: TSF+0x14			Register Name: <b>TSF_OIER</b>
Bit	R/W	Default/Hex	Description
31:0	R/W	0x0	OLPIE Overlap Interrupt Enable Overlap interrupt enable bits for channel 0~31.

**8.10.4.19. TSF DMA Interrupt Status Register(Default Value: 0x00000000)**

Offset: TSF+0x18			Register Name: <b>TSF_DISR</b>
Bit	R/W	Default/Hex	Description
31:0	R/W	0x0	DMAIS DMA Interrupt Status DMA interrupt Status bits for channel 0~31. Set by hardware, and can be cleared by software writing '1'. When both these bits and the corresponding DMA Interrupt Enable bits set, the TSF interrupt will generate.

**8.10.4.20. TSF Overlap Interrupt Status Register(Default Value: 0x00000000)**

Offset: TSF+0x1C			Register Name: <b>TSF_OISR</b>
------------------	--	--	--------------------------------

Bit	R/W	Default/Hex	Description
31:0	R/W	0x0	OLPIS Overlap Interrupt Status Overlap interrupt Status bits for channel 0~31. Set by hardware, and can be cleared by software writing '1'. When both these bits and the corresponding Overlap Interrupt Enable bits set, the TSF interrupt will generate.

**8.10.4.21. TSF PCR Control Register(Default Value: 0x00000000)**

Offset: TSF+0x20			Register Name: <b>TSF_PCRCR</b>
Bit	R/W	Default/Hex	Description
31:17	/	/	/
16	R/W	0	PCRDE PCR Detecting Enable 0: Disable 1: Enable
15:13	/	/	/
12:8	R/W	0	PCRCIND Channel Index m for Detecting PCR packet (m from 0 to 31)
7:1	/	/	/
0	R	0	PCRLSB PCR Contest LSB 1 bit PCR[0]

**8.10.4.22. TSF PCR Data Register(Default Value: 0x00000000)**

Offset: TSF+0x24			Register Name: <b>TSF_PCRDR</b>
Bit	R/W	Default/Hex	Description
31:0	R	0	PCRMSB PCR Data High 32 bits PCR[33:1]

**8.10.4.23. TSF Channel Enable Register(Default Value: 0x00000000)**

Offset: TSF+0x30			Register Name: <b>TSF_CENR</b>
Bit	R/W	Default/Hex	Description
31:0	R/W	0	FilterEn Filter Enable for Channel 0~31 0: Disable 1: Enable

			From Disable to Enable, internal status of the corresponding filter channel will be reset.
--	--	--	--

**8.10.4.24. TSF PES Enable Register(Default Value: 0x00000000)**

Offset: TSF+0x34			Register Name: <b>TSF_CPER</b>
Bit	R/W	Default/Hex	Description
31:0	R/W	0x0	PESEn PES Packet Enable for Channel 0~31 0: Disable 1: Enable These bits should not be changed during the corresponding channel enable.

**8.10.4.25. TSF Channel Descramble Enable Register(Default Value: 0x00000000)**

Offset: TSF+0x38			Register Name: <b>TSF_CDERR</b>
Bit	R/W	Default/Hex	Description
31:0	R/W	0x0	DescEn Descramble Enable for Channel 0~31 0: Disable 1: Enable These bits should not be changed during the corresponding channel enable.

**8.10.4.26. TSF Channel Index Register(Default Value: 0x00000000)**

Offset: TSF+0x3C			Register Name: <b>TSF_CINDR</b>
Bit	R/W	Default/Hex	Description
31:5	/	/	/
4:0	R/W	0x0	CHIND Channel Index This value is the channel index for channel private registers access. Range is from 0x00 to 0x1f. Address range of channel private registers is 0x40~0x7f.

**8.10.4.27. TSF Channel Control Register(Default Value: 0x00000000)**

Offset: TSF+0x40			Register Name: <b>TSF_CCTLR</b>
------------------	--	--	---------------------------------

Bit	R/W	Default/Hex	Description
31:0	/	/	/

**8.10.4.28. TSF Channel Status Register(Default Value: 0x00000000)**

Offset: TSF+0x44			Register Name: <b>TSF_CSTAR</b>
Bit	R/W	Default/Hex	Description
31:0	/	/	/

**8.10.4.29. TSF Channel CW Index Register(Default Value: 0x00000000)**

Offset: TSF+0x48			Register Name: <b>TSF_CCWIR</b>
Bit	R/W	Default/Hex	Description
31:3	/	/	/
2:0	R/W	0x0	CWIND Related Control Word Index Index to the control word used by this channel when Descramble Enable of this channel enable. This value is useless when the corresponding Descramble Enable is '0'.

**8.10.4.30. TSF Channel PID Register(Default Value: 0x1FFF0000)**

Offset: TSF+0x4C			Register Name: <b>TSF_CPIDR</b>
Bit	R/W	Default/Hex	Description
31:16	R/W	0x1fff	PIDMSK Filter PID Mask for Channel
15:0	R/W	0x0	PIDVAL Filter PID value for Channel

**8.10.4.31. TSF Channel Buffer Base Address Register(Default Value: 0x00000000)**

Offset: TSF+0x50			Register Name: <b>TSF_CBBAR</b>
Bit	R/W	Default/Hex	Description
31:28	/	/	/
27:0	R/W	0	TSFBufBAddr Data Buffer Base Address for Channel It is 4-word (16Bytes) align address. The LSB four bits should be zero.

**8.10.4.32. TSF Channel Buffer Size Register(Default Value: 0x00000000)**

Offset: TSF+0x54			Register Name: <b>TSF_CBSZR</b>
Bit	R/W	Default/Hex	Description
31:26	/	/	/
25:24	R/W	0	<p>CHDMAIntThd DMA Interrupt Threshold for Channel The unit is TS packet size. When received packet (has also stored in DRAM) size is beyond (&gt;=) threshold value, the corresponding channel interrupt is generated to CPU. TSC should count the new received packet again, when exceed the specified threshold value, one new interrupt is generated again.</p> <p>0: 1/2 data buffer packet size 1: 1/4 data buffer packet size 2: 1/8 data buffer packet size 3: 1/16 data buffer packet size</p>
23:21	/	/	/
20:0	R/W	0	<p>CHBufPktSz Data Buffer Packet Size for Channel The exact buffer size of buffer is N+1 bytes. The maximum buffer size is 2MB. This size should be 4-word (16Bytes) aligned. The LSB four bits should be zero.</p>

**8.10.4.33. TSF Channel Write Pointer Register(Default Value: 0x00000000)**

Offset: TSF+0x58			Register Name: <b>TSF_CBWPR</b>
Bit	R/W	Default/Hex	Description
31:21	/	/	/
20:0	R/W	0	<p>BufWrPtr Data Buffer Write Pointer (in Bytes) This value is changed by hardware, when data is filled into buffer, this pointer is increased. And this pointer can be set by software, but it should not be changed by software during the corresponding channel is enable.</p>

**8.10.4.34. TSF Channel Read Pointer Register(Default Value: 0x00000000)**

Offset: TSF+0x5C			Register Name: <b>TSF_CBRPR</b>
Bit	R/W	Default/Hex	Description
31:21	/	/	/
20:0	R/W	0	<p>BufRdPtr Data Buffer Read Pointer (in Bytes)</p>



			This pointer should be changed by software after the data of buffer is read.
--	--	--	--

**8.10.4.35. TSD Control Register(Default Value: 0x00000000)**

Offset: TSD+0x00			Register Name: <b>TSD_CTLR</b>
Bit	R/W	Default/Hex	Description
31:2	/	/	/
1:0	R/W	0x0	DescArith Descramble Arithmetic 00: DVB CSA V1.1 Others: Reserved

**8.10.4.36. TSD Status Register(Default Value: 0x00000000)**

Offset: TSD+0x04			Register Name: <b>TSD_STAR</b>
Bit	R/W	Default/Hex	Description
31:0	/	/	/

**8.10.4.37. TSD Control Word Index Register(Default Value: 0x00000000)**

Offset: TSD+0x1C			Register Name: <b>TSD_CWIR</b>
Bit	R/W	Default/Hex	Description
31:3	/	/	/
6:4	R/W	0x0	CWI Control Word Index This value is the Control index for Control word access. Range is from 0x00 to 0x7.
3:2	/	/	/
1:0	R/W	0x0	CWII Control Word Internal Index 0 – Odd Control Word Low 32-bit, OCW[31:0]; 1 – Odd Control Word High 32-bit, OCW[63:32]; 2 – Even Control Word Low 32-bit, ECW[31:0]; 3 – Even Control Word High 32-bit, ECW[63:0];

**8.10.4.38. TSD Control Word Register(Default Value: 0x00000000)**

Offset: TSD+0x20			Register Name: <b>TSD_CWR</b>
Bit	R/W	Default/Hex	Description

31:0	R/W	0x0	CWD Content of Control Word corresponding to the TSD_CWIR value
------	-----	-----	--

Confidential

## Chapter 9 Electrical Characteristics

### 9.1. Absolute Maximum Ratings

Absolute Maximum Ratings are those values beyond which damage to the device may occur. Table 9-1 specifies the absolute maximum ratings over the operating junction temperature range of commercial and extended temperature devices. Functional operation of the device at these or any other conditions beyond those indicated in the operational sections of this standard may damage to the device.

Table 9-1. Absolute Maximum Ratings

Symbol	Parameter	MIN	Max	Unit
$I_{I/O}$	In/Out current for input and output	-40	40	mA
AVCC	Power Supply for Analog part	-0.3	3.4	V
EPHY_VCC	Power Supply for EPHY	-0.3	3.8	V
EPHY_VDD	Power Supply for EPHY	-0.3	1.4	V
HVCC	Power Supply for HDMI	-0.3	3.6	V
V33_TV	Power Supply for TV	-0.3	3.6	V
VCC_IO	Power Supply for Port A	-0.3	3.6	V
VCC_PD	Power Supply for Port D	-0.3	3.6	V
VCC_PG	Power Supply for Port G	-0.3	3.6	V
VCC_PLL	Power Supply for system PLL	-0.3	3.6	V
VCC_RTC	Power Supply for RTC	-0.3	3.6	V
VCC_USB	Power Supply for USB	-0.3	3.6	V
VCC-DRAM	Power Supply for DRAM	-0.3	1.98	V
VDD_CPUS	Power Supply for CPUS	-0.3	1.4	V
VDD_CPUX	Power Supply for CPU	-0.3	1.5	V
VDD_EFUSE	Power Supply for EFUSE	-0.3	3.6	V
VDD_SYS	Power Supply for System	-0.3	1.4	V
$T_{STG}$	Storage Temperature	-40	125	°C

## 9.2. Recommended Operating Conditions

All H3 modules are used under the operating Conditions contained in Table 9-2.

Table 9-2. Recommended Operating Conditions

Symbol	Parameter	Min	Typ	Max	Unit
Ta	Ambient Operating Temperature	-20	-	+70	°C
AVCC	Power Supply for Analog part	-	3.3	-	V
EPHY_VCC	Power Supply for EPHY	2.8	3.3	3.6	V
EPHY_VDD	Power Supply for EPHY	1.0	1.1	1.2	V
HVCC	Power Supply for HDMI	3.0	3.3	3.6	V
V33_TV	Power Supply for TV	3.0	3.3	3.6	V
VCC_IO	Power Supply for Port A	1.7	1.8~3.3	3.6	V
VCC_PD	Power Supply for Port D	1.7	1.8~3.3	3.6	V
VCC_PG	Power Supply for Port G	1.7	1.8~3.3	3.6	V
VCC_PLL	Power Supply for System PLL	3.0	3.3	3.6	V
VCC_RTC	Power Supply for RTC	3.0	3.3	3.6	V
VCC_USB	Power Supply for USB	3.0	3.3	3.45	V
VCC-DRAM	Power Supply for DRAM IO Domain(DDR3)	1.425	1.5	1.575	V
	Power Supply for DRAM IO Domain(DDR3L)	1.283	1.35	1.45	V
	Power Supply for DRAM IO Domain(LPDDR2/LPDDR3)	1.14	1.2	1.3	V
	Power Supply for DRAM IO Domain(DDR2)	1.7	1.8	1.9	V
VDD_CPUS	Power Supply for CPUS	1.1	1.2	1.3	V
VDD_CPUX	Power Supply for CPU	1.1	1.2	1.4	V
VDD_EFUSE	Power Supply for EFUSE	3.0	3.3	3.6	V
VDD_SYS	Power Supply for System	1.1	1.2	1.3	V

### 9.3. DC Electrical Characteristics

Table 9-3 summarizes the DC electrical characteristics of H3.

Table 9-3. DC Electrical Characteristics

Symbol	Parameter	Min	Typ	Max	Unit
VIH	High-Level Input Voltage	$0.7 \cdot V_{CC\_IO}$	-	$V_{CC\_IO} + 0.3$	V
VIL	Low-Level Input Voltage	-0.3	-	$0.3 \cdot V_{CC\_IO}$	V
RPU	Input pull-up resistance	50	100	150	K $\Omega$
RPD	Input pull-down resistance	50	100	150	K $\Omega$
IIH	High-Level Input Current	-	-	10	$\mu$ A
IIL	Low-Level Input Current	-	-	10	$\mu$ A
VOH	High-Level Output Voltage	$V_{CC\_IO} - 0.2$	-	$V_{CC\_IO}$	V
VOL	Low-Level Output Voltage	0	-	0.2	V
IOZ	Tri-State Output Leakage Current	-10	-	10	$\mu$ A
CIN	Input Capacitance	-	-	5	pF
COUT	Output Capacitance	-	-	5	pF

Confidential

## 9.4. Oscillator Electrical Characteristics

H3 contains two external input clocks: X24MIN and X32KIN, two output clocks: X24MOUT and X32KOUT. The 24.000MHz frequency is used to generate the main source clock for PLL and the main digital blocks, the clock is provided through X24MIN. Table 9-4 lists the 24MHz crystal specifications.

Table 9-4. 24MHz Oscillator Characteristics

Symbol	Parameter	Min	Typ	Max	Unit
$1/(t_{CPMAIN})$	Crystal Oscillator Frequency Range	–	24.000	–	MHz
$t_{ST}$	Startup Time	–	–	–	ms
	Frequency Tolerance at 25 °C	-40	–	+40	ppm
	Oscillation Mode	Fundamental			–
	Maximum change over temperature range	-50	–	+50	ppm
$P_{ON}$	Drive level	–	–	50	uW
$C_L$	Equivalent Load capacitance	–	–	–	pF
CL1,CL2	Internal Load capacitance(CL1=CL2)	–	–	–	pF
$R_S$	Series Resistance(ESR)	–	–	–	Ω
	Duty Cycle	30	50	70	%
$C_M$	Motional capacitance	–	–	–	pF
$C_{SHUT}$	Shunt capacitance	–	–	–	pF
$R_{BIAS}$	Internal bias resistor	–	–	–	MΩ

The 32768Hz frequency is used for low frequency operation. It supplies the wake-up domain for operation in lowest power mode. The clock is provided through X32KIN. Table 9-5 lists the 32768Hz crystal specifications.

Table 9-5. 32768Hz Oscillator Characteristics

Symbol	Parameter	Min	Typ	Max	Unit
$1/(t_{CPMAIN})$	Crystal Oscillator Frequency Range	–	32768	–	Hz
$t_{ST}$	Startup Time	–	–	–	ms
	Frequency Tolerance at 25 °C	-40	–	+40	ppm
	Oscillation Mode	Fundamental			–
	Maximum change over temperature range	-50	–	+50	ppm
$P_{ON}$	Drive level	–	–	50	uW
$C_L$	Equivalent Load capacitance	–	–	–	pF
CL1,CL2	Internal Load capacitance(CL1=CL2)	–	–	–	pF
$R_S$	Series Resistance(ESR)	–	–	–	Ω
	Duty Cycle	30	50	70	%
$C_M$	Motional capacitance	–	–	–	pF
$C_{SHUT}$	Shunt capacitance	–	–	–	pF
$R_{BIAS}$	Internal bias resistor	–	–	–	MΩ

### 9.5. Power on and Power off Sequence

The external voltage regulator and other power-on devices must provide the processor with a specific sequence of power and resets to ensure proper operations. Following figure 9-1 and figure 9-2 provides the timing requirements for the H3 power.

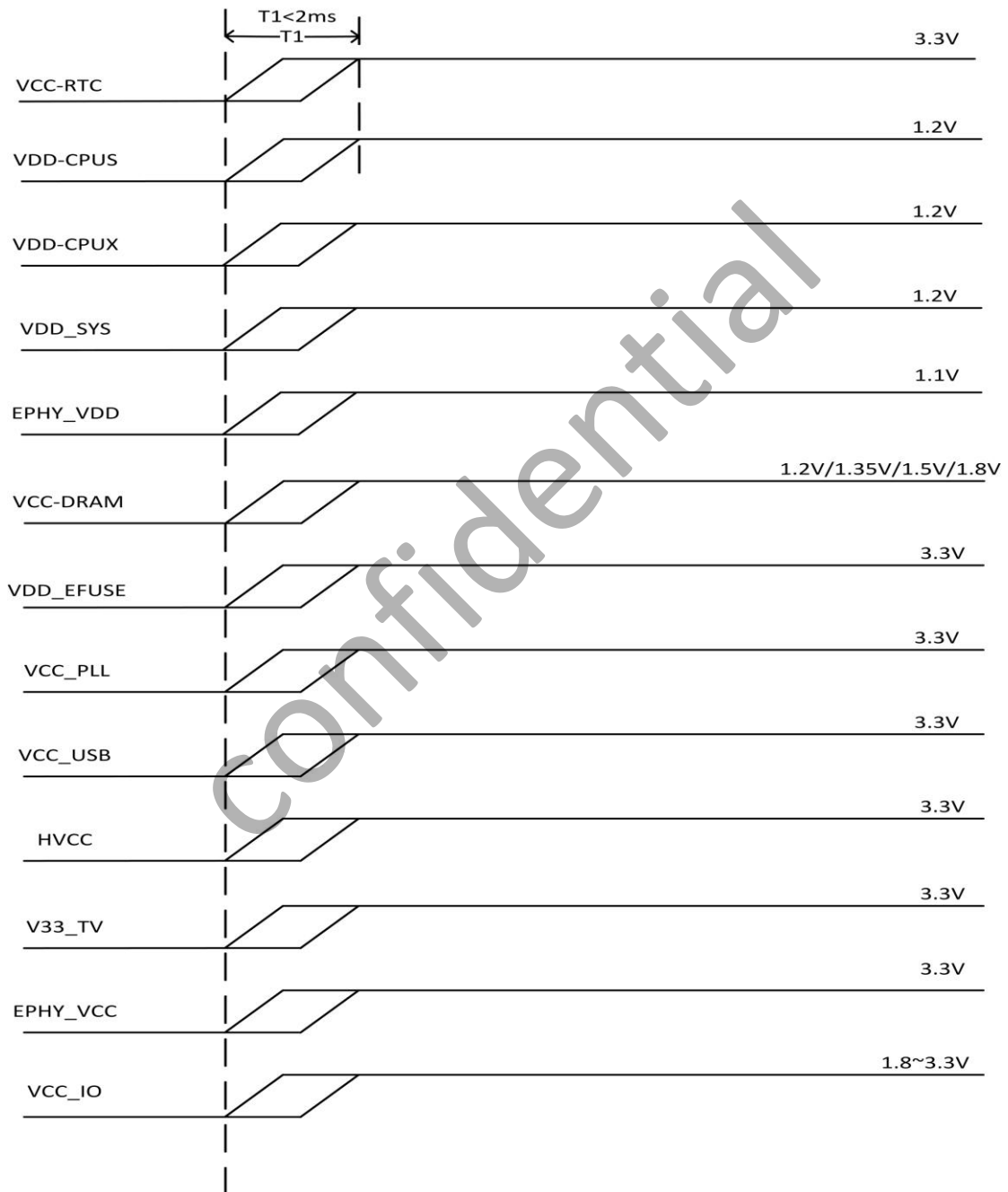

Figure 9-1. Power On Sequence



Figure 9-2. Power Down Sequence



# Appendix

## Pin Map

The following pin maps show the top views of the 347-pin FBGA package of H3 processor.

	1	2	3	4	5	6	7	8	9	10	11	12	13	14	15	16	17	18	19	20	21		
A	JTAG-SE L0	EPHY_LI NK_LED	EPHY_T XN	EPHY_R XN	USB_DP 0		USB_DP 2	USB_D M2		PE1	PE11		PA20	PA21		PC7	PC5		PF1	PD4	GND	A	
B	PG13	JTAG-SE L1	EPHY_T XP	EPHY_R XP	USB_D M0	USB_DP 1	USB_D M1	USB_DP 3	USB_D M3	PE0	PE2	PE12	PA18	PA19	PC3	PC2	PC12	PC8	PC13	PD2	PD6	B	
C	PG5	PG4	PG8		PE15	PE14	PE13	PE7	PE4	PE3	PE8	PE9	PA12	PA17	PC0	PC1	PC9	PC11	PC15	PF5	PD0	C	
D	PG12	PG11	PG7		PA1	PA2		PA7		PE6	PA0		PA9		PA16		PC10		PF0	PF2		D	
E		HTXCN	PG9					PE10		PE5	PA10		PA3	PA6	PA13	PC6		PD7	PD12	PD8	PF4	E	
F	HTX0N	HTXCP	PG3		PA4	EPHY_R TX	EPHY_S PD_LED	EPHY_V DD		TVOUT	PA11		PA8	PA15		PC4	PC14	PF3	PD5	PD11	PD9	F	
G	HTX0P	HTX1N		PG6	HCEC		EPHY_V CC	GND	V33_TV	VDD_EF USE	VCC_US B	PA14	VCC_IO	VCC_IO	VCC_IO			PF6		SDQM1		G	
H		HTX1P	H5CL	PG2		PA5	VCC_PG	GND_TV		VDD_SY S	VDD_EF USEBP	GND	VCC_IO	VCC_IO	GND	PC16	PD1	PD3	PD10	SDQ9	SDQ10	H	
J	HTX2P	HTX2N	PG0		HVCC	VDD_CP US	VDD_CP US	GND		VDD_SY S	VDD_SY S	VDD_SY S	GND	VCC_IO	VCC_PD	GND				SDQ8	SDQS1B	SDQ11	J
K	X24MO UT	X24MIN	HSDA	NC		VCC_RT C	GND	GND	GND	VDD_SY S	VDD_SY S	VDD_SY S	GND	GND	GND	GND	PD13	PD15		SDQS1		K	
L		PG1			PLLTEST			GND	GND	VDD_SY S	VDD_SY S	VDD_SY S	VDD_SY S	VDD_SY S	GND	VCC-DR AM	PD14	PD16	PD17	SDQ12	SDQ13	L	
M	PL1	HHPD	PG10	RTC_VIO	HGND	PL9	GND	GND	GND	GND	GND	GND	GND	GND	GND	VCC-DR AM				SDQ15	SDQM0	SDQ14	M
N	PL0	PL4	VCC_PLL				GND	VDD_CP UX	GND	GND	GND	GND	GND	GND	GND	VCC-DR AM	SA14		SA11	SDQ0		N	
P		PL2	X32KFO UT				VDD_CP UX	VDD_CP UX	VDD_CP UX	VDD_CP UX	GND	GND	GND	GND	GND	VCC-DR AM	VCC-DR AM		SA10	SDQ2	SDQ1	P	
R	PL3	PL5					VDD_CP UX	VDD_CP UX	VDD_CP UX	GND	GND	GND	GND	GND	GND	VCC-DR AM	SA15	SA12	SDQ4	SDQS0	SDQS0B	R	
T		PL8	PL7	PL6	TEST		VDD_CP UX	VDD_CP UX	VDD_CP UX	GND-CP UFB	VDD_CP UFB	GND	VCC-DR AM	VCC-DR AM	VCC-DR AM	VCC-DR AM	SVREF	SA0	SBA1		SDQ5		T
U		PL11	AGND	X32KOU T			VDD_CP UX	VDD_CP UX				VCC-DR AM			SCAS	SRST		SA1	SDQ6	SDQ7	SDQ3	U	
V	LINEINL	PL10	AVCC	VRP	X32KIN	RESET				SZQ	SODT1	SA13	SRAS		SA7		SBA2		SA2	SA3	SA4	V	
W	LINEINR	MICIN1P	MBIAS		VRA2	UBOOT				SDQ28		SODT0	SDQ24	SWE		SDQ19		SBA0	SA8		SCS0	SCS1	W
Y	MICIN1 N	MICIN2P	LINEOU TR	VRA1			SDQ31	SDQ30	SDQS3B	SDQ27	SDQ26	SDQ23	SDQ22	SDQ20	SDQS2B	SDQ18	SDQ16	SA9	SA5	SA6	SCKE1	Y	
AA	GND	MICIN2 N	LINEOU TL		KEYADC	NMI		SDQ29	SDQS3		SDQ25	SDQM3		SDQ21	SDQS2		SDQ17	SDQM2	SCK	SCKB	SCKE0	AA	

Package Dimension

The following diagram shows the package dimension of H3 processor, includes the top, bottom, side views and details of the 14mmx14mm package.

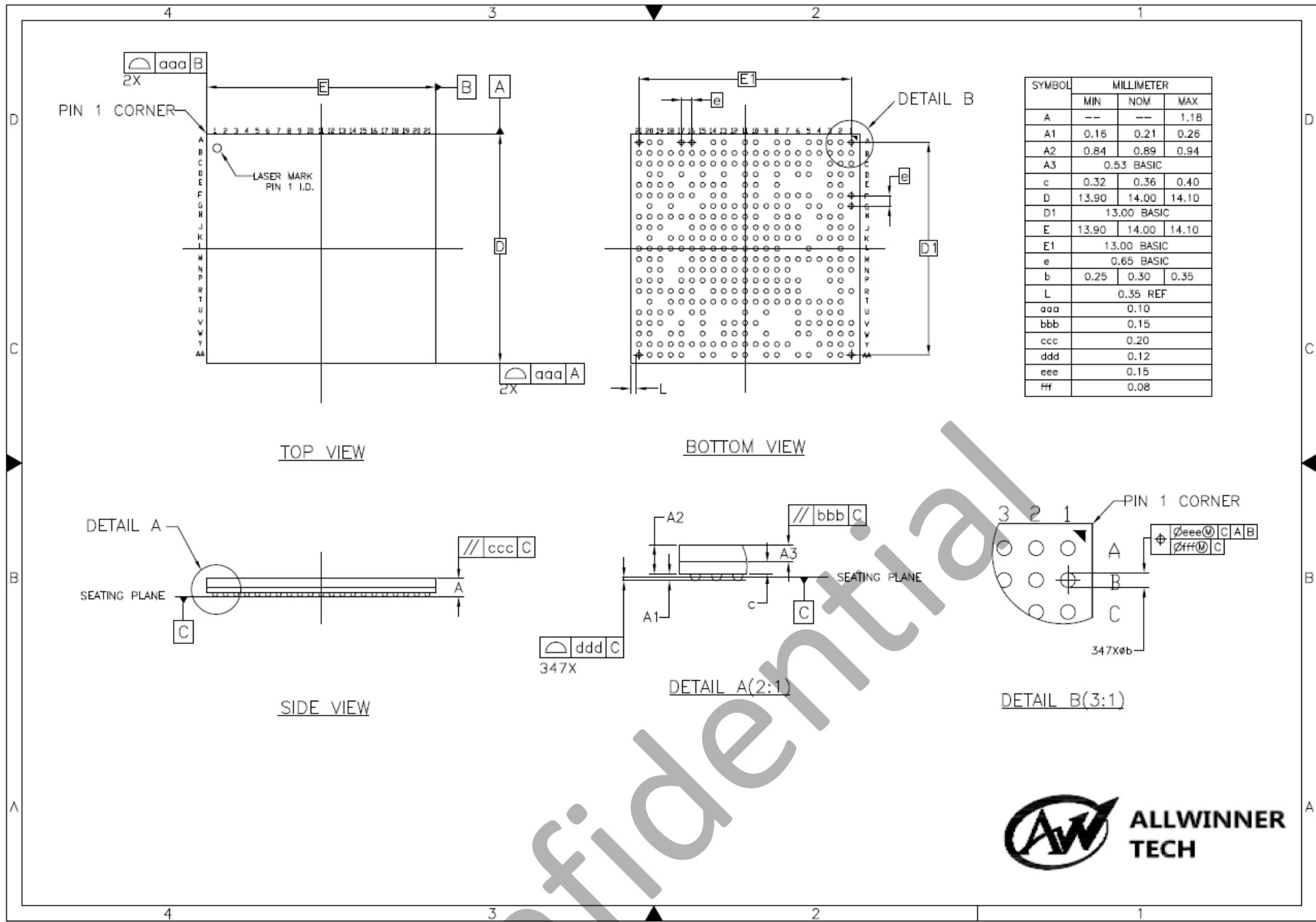

Confidential

