



# Rabbit<sup>®</sup> 5000 Microprocessor

## User's Manual

019-0168 • 080615-A

# Rabbit 5000 Microprocessor User's Manual

Part Number 019-0168 • 080615–A • Printed in U.S.A.

©2008 Digi International Inc. • All rights reserved.

No part of the contents of this manual may be reproduced or transmitted in any form or by any means without the express written permission of Digi International.

Permission is granted to make one or more copies as long as the copyright page contained therein is included. These copies of the manuals may not be let or sold for any reason without the express written permission of Digi International.

Digi International reserves the right to make changes and improvements to its products without providing notice.

## Trademarks

Rabbit and Dynamic C are registered trademarks of Digi International Inc.

Rabbit 5000 is a trademark of Digi International Inc.

The latest revision of this manual is available on the Rabbit Web site, [www.rabbit.com](http://www.rabbit.com), for free, unregistered download.

**Rabbit Semiconductor Inc.**

[www.rabbit.com](http://www.rabbit.com)

# TABLE OF CONTENTS

<b>Chapter 1. The Rabbit 5000 Processor</b>	<b>1</b>
1.1 Introduction.....	1
1.2 Features.....	2
1.3 Block Diagram.....	4
1.4 Basic Specifications.....	5
1.5 Comparing Rabbit Microprocessors.....	6
<b>Chapter 2. Clocks</b>	<b>9</b>
2.1 Overview.....	9
2.1.1 Block Diagram.....	10
2.1.2 Registers.....	10
2.2 Dependencies.....	11
2.2.1 I/O Pins.....	11
2.2.2 Other Registers.....	11
2.3 Operation.....	12
2.3.1 Main Clock.....	12
2.3.2 Spectrum Spreader.....	13
2.3.3 Clock Doubler.....	15
2.3.4 32 kHz Clock.....	18
2.4 Register Descriptions.....	20
<b>Chapter 3. Reset and Bootstrap</b>	<b>25</b>
3.1 Overview.....	25
3.1.1 Block Diagram.....	26
3.1.2 Registers.....	26
3.2 Dependencies.....	27
3.2.1 I/O Pins.....	27
3.2.2 Clocks.....	27
3.2.3 Other Registers.....	27
3.2.4 Interrupts.....	27
3.3 Operation.....	28
3.3.1 Asynchronous Serial Bootstrap.....	30
3.3.2 Serial Flash Bootstrap.....	30
3.3.3 Parallel Bootstrap.....	31
3.4 Register Descriptions.....	32
<b>Chapter 4. System Management</b>	<b>33</b>
4.1 Overview.....	33
4.1.1 Block Diagram.....	34
4.1.2 Registers.....	35
4.2 Dependencies.....	36
4.2.1 I/O Pins.....	36
4.2.2 Clocks.....	36
4.2.3 Interrupts.....	36

4.3	Operation .....	37
4.3.1	Periodic Interrupt .....	37
4.3.2	Real-Time Clock .....	37
4.3.3	Watchdog Timer .....	38
4.3.4	Secondary Watchdog Timer .....	38
4.4	Register Descriptions .....	39
<b>Chapter 5. Memory Management</b>		<b>45</b>
5.1	Overview .....	45
5.1.1	Block Diagram .....	48
5.1.2	Registers .....	49
5.2	Dependencies .....	50
5.2.1	I/O Pins .....	50
5.2.2	Clocks .....	50
5.2.3	Other Registers .....	50
5.2.4	Interrupts .....	50
5.3	Operation .....	51
5.3.1	Memory Management Unit (MMU) .....	51
5.3.2	Memory Bank Operation .....	52
5.3.3	Memory Modes .....	54
5.3.4	Separate Instruction and Data Space .....	56
5.3.5	Memory Protection .....	56
5.3.6	Stack Protection .....	57
5.4	Register Descriptions .....	58
<b>Chapter 6. Interrupts</b>		<b>69</b>
6.1	Overview .....	69
6.2	Operation .....	70
6.3	Interrupt Tables .....	70
<b>Chapter 7. External Interrupts</b>		<b>73</b>
7.1	Overview .....	73
7.2	Block Diagram .....	73
7.2.1	Registers .....	74
7.3	Dependencies .....	74
7.3.1	I/O Pins .....	74
7.3.2	Clocks .....	74
7.3.3	Interrupts .....	74
7.4	Operation .....	74
7.4.1	Example ISR .....	74
7.5	Register Descriptions .....	75
<b>Chapter 8. Parallel Port A</b>		<b>77</b>
8.1	Overview .....	77
8.1.1	Block Diagram .....	77
8.1.2	Registers .....	77
8.2	Dependencies .....	78
8.2.1	I/O Pins .....	78
8.2.2	Clocks .....	78
8.2.3	Other Registers .....	78
8.2.4	Interrupts .....	78
8.3	Operation .....	78
8.4	Register Descriptions .....	79

<b>Chapter 9. Parallel Port B</b>	<b>81</b>
9.1 Overview.....	81
9.1.1 Block Diagram .....	82
9.1.2 Registers .....	82
9.2 Dependencies.....	82
9.2.1 I/O Pins .....	82
9.2.2 Clocks .....	82
9.2.3 Other Registers .....	82
9.2.4 Interrupts .....	83
9.3 Operation .....	83
9.4 Register Descriptions.....	83
<b>Chapter 10. Parallel Port C</b>	<b>85</b>
10.1 Overview.....	85
10.1.1 Block Diagram .....	86
10.1.2 Registers .....	86
10.2 Dependencies.....	87
10.2.1 I/O Pins .....	87
10.2.2 Clocks .....	87
10.2.3 Other Registers .....	87
10.2.4 Interrupts .....	87
10.3 Operation .....	87
10.4 Register Descriptions.....	88
<b>Chapter 11. Parallel Port D</b>	<b>93</b>
11.1 Overview.....	93
11.1.1 Block Diagram .....	95
11.1.2 Registers .....	96
11.2 Dependencies.....	97
11.2.1 I/O Pins .....	97
11.2.2 Clocks .....	97
11.2.3 Other Registers .....	97
11.2.4 Interrupts .....	97
11.3 Operation .....	98
11.4 Register Descriptions.....	99
<b>Chapter 12. Parallel Port E</b>	<b>111</b>
12.1 Overview.....	111
12.1.1 Block Diagram .....	113
12.1.2 Registers .....	114
12.2 Dependencies.....	114
12.2.1 I/O Pins .....	114
12.2.2 Clocks .....	114
12.2.3 Other Registers .....	115
12.2.4 Interrupts .....	115
12.3 Operation .....	115
12.4 Register Descriptions.....	116
<b>Chapter 13. Parallel Port H</b>	<b>131</b>
13.1 Overview.....	131
13.1.1 Block Diagram .....	132
13.1.2 Registers .....	132
13.2 Dependencies.....	133
13.2.1 I/O Pins .....	133
13.2.2 Clocks .....	133
13.2.3 Other Registers .....	133
13.2.4 Interrupts .....	133
13.3 Operation .....	133
13.4 Register Descriptions.....	134

<b>Chapter 14. Timer A</b>	<b>137</b>
14.1 Overview .....	137
14.1.1 Block Diagram .....	139
14.1.2 Registers .....	140
14.2 Dependencies .....	140
14.2.1 I/O Pins .....	140
14.2.2 Clocks .....	140
14.2.3 Other Registers .....	140
14.2.4 Interrupts .....	141
14.3 Operation .....	141
14.3.1 Handling Interrupts .....	141
14.3.2 Example ISR .....	141
14.4 Register Descriptions .....	142
<b>Chapter 15. Timer B</b>	<b>145</b>
15.1 Overview .....	145
15.1.1 Block Diagram .....	145
15.1.2 Registers .....	146
15.2 Dependencies .....	146
15.2.1 I/O Pins .....	146
15.2.2 Clocks .....	146
15.2.3 Other Registers .....	146
15.2.4 Interrupts .....	146
15.3 Operation .....	147
15.3.1 Handling Interrupts .....	147
15.3.2 Example ISR .....	147
15.4 Register Descriptions .....	148
<b>Chapter 16. Timer C</b>	<b>151</b>
16.1 Overview .....	151
16.1.1 Block Diagram .....	152
16.1.2 Registers .....	153
16.2 Dependencies .....	154
16.2.1 I/O Pins .....	154
16.2.2 Clocks .....	154
16.2.3 Other Registers .....	154
16.2.4 Interrupts .....	154
16.3 Operation .....	155
16.3.1 Handling Interrupts .....	155
16.3.2 Example ISR .....	155
16.4 Register Descriptions .....	156
<b>Chapter 17. Serial Ports A – D</b>	<b>159</b>
17.1 Overview .....	159
17.1.1 Block Diagram .....	161
17.1.2 Registers .....	162
17.2 Dependencies .....	163
17.2.1 I/O Pins .....	163
17.2.2 Clocks .....	163
17.2.3 Other Registers .....	164
17.2.4 Interrupts .....	164
17.3 Operation .....	165
17.3.1 Asynchronous Mode .....	165
17.3.2 Clocked Serial Mode .....	166
17.4 Register Descriptions .....	168

<b>Chapter 18. Serial Ports E – F</b>	<b>175</b>
18.1 Overview .....	175
18.1.1 Block Diagram .....	176
18.1.2 Registers .....	177
18.2 Dependencies .....	178
18.2.1 I/O Pins .....	178
18.2.2 Clocks .....	178
18.2.3 Other Registers .....	178
18.2.4 Interrupts .....	179
18.3 Operation .....	180
18.3.1 Asynchronous Mode .....	180
18.3.2 HDLC Mode .....	180
18.3.3 More on Clock Synchronization and Data Encoding .....	181
18.4 Register Descriptions .....	185
<b>Chapter 19. Slave Port</b>	<b>191</b>
19.1 Overview .....	191
19.1.1 Block Diagram .....	192
19.1.2 Registers .....	192
19.2 Dependencies .....	193
19.2.1 I/O Pins .....	193
19.2.2 Clocks .....	193
19.2.3 Interrupts .....	193
19.3 Operation .....	194
19.3.1 Master Setup .....	195
19.3.2 Slave Setup .....	195
19.3.3 Master/Slave Communication .....	196
19.3.4 Slave/Master Communication .....	196
19.3.5 Handling Interrupts .....	196
19.3.6 Example ISR .....	196
19.3.7 Other Configurations .....	197
19.3.8 Timing Diagrams .....	198
19.4 Register Descriptions .....	200
<b>Chapter 20. Analog Components</b>	<b>203</b>
20.1 Overview .....	203
20.2 Block Diagram .....	206
20.2.1 Registers .....	207
20.3 Dependencies .....	207
20.3.1 I/O Pins .....	207
20.3.2 Clocks .....	207
20.4 Operation .....	208
20.4.1 Fast A/D Converter .....	208
20.4.2 Fast D/A Converter .....	208
20.4.3 Slow A/D Converter .....	208
20.5 Sample Circuits .....	209
20.6 Register Descriptions .....	211
<b>Chapter 21. DMA Channels</b>	<b>217</b>
21.1 Overview .....	217
21.1.1 Block Diagram .....	220
21.1.2 Registers .....	221
21.2 Dependencies .....	222
21.2.1 I/O Pins .....	222
21.2.2 Clocks .....	222
21.2.3 Interrupts .....	222
21.3 Operation .....	223
21.3.1 Handling Interrupts .....	224
21.3.2 Example ISR .....	224

21.3.3 DMA Priority with the Processor .....	224
21.3.4 DMA Channel Priority .....	226
21.3.5 Buffer Descriptor Modes .....	226
21.3.5.1 Single Buffer .....	227
21.3.5.2 Buffer Array .....	227
21.3.5.3 Linked List .....	228
21.3.5.4 Circular Queue .....	229
21.3.5.5 Linked Array .....	229
21.3.6 DMA with Peripherals .....	230
21.3.6.1 DMA with HDLC Serial Ports .....	230
21.3.6.2 DMA with Ethernet .....	230
21.3.6.3 DMA with Wi-Fi .....	230
21.3.6.4 DMA with PWM and Timer C .....	230
21.4 Register Descriptions .....	231
<b>Chapter 22. 10/100Base-T Ethernet</b> .....	<b>245</b>
22.1 Overview .....	245
22.1.1 Block Diagram .....	247
22.1.2 Registers .....	248
22.2 Dependencies .....	250
22.2.1 I/O Pins .....	250
22.2.2 Clocks .....	250
22.2.3 Other Registers .....	250
22.2.4 Interrupts .....	251
22.3 Operation .....	251
22.3.1 Setup .....	252
22.3.2 Transmit .....	252
22.3.3 Receive .....	252
22.3.4 Handling Interrupts .....	253
22.3.5 Multicast Addressing .....	254
22.4 Register Descriptions .....	255
<b>Chapter 23. 802.11b/g Wireless</b> .....	<b>269</b>
23.1 Overview .....	269
23.1.1 Block Diagram .....	270
23.1.2 Registers .....	271
23.2 Dependencies .....	273
23.2.1 I/O Pins .....	273
23.3 Clocks .....	274
23.3.1 Other Registers .....	274
23.3.2 Interrupts .....	274
23.4 Operation .....	274
<b>Chapter 24. Input Capture</b> .....	<b>275</b>
24.1 Overview .....	275
24.1.1 Block Diagram .....	276
24.1.2 Registers .....	277
24.2 Dependencies .....	278
24.2.1 I/O Pins .....	278
24.2.2 Clocks .....	278
24.2.3 Other Registers .....	278
24.2.4 Interrupts .....	278
24.3 Operation .....	279
24.3.1 Input-Capture Channel .....	279
24.3.2 Handling Interrupts .....	279
24.3.3 Example ISR .....	279
24.3.4 Capture Mode .....	280
24.3.5 Count Mode .....	280
24.4 Register Descriptions .....	281



<b>Chapter 25. Quadrature Decoder</b>	<b>287</b>
25.1 Overview .....	287
25.1.1 Block Diagram .....	289
25.1.2 Registers .....	289
25.2 Dependencies .....	290
25.2.1 I/O Pins .....	290
25.2.2 Clocks .....	290
25.2.3 Other Registers .....	290
25.2.4 Interrupts .....	290
25.3 Operation .....	291
25.3.1 Handling Interrupts .....	291
25.3.2 Example ISR .....	291
25.4 Register Descriptions .....	292
<b>Chapter 26. Pulse Width Modulator</b>	<b>295</b>
26.1 Overview .....	295
26.1.1 Block Diagram .....	297
26.1.2 Registers .....	297
26.2 Dependencies .....	298
26.2.1 I/O Pins .....	298
26.2.2 Clocks .....	298
26.2.3 Other Registers .....	298
26.2.4 Interrupts .....	298
26.3 Operation .....	299
26.3.1 Handling Interrupts .....	299
26.3.2 Example ISR .....	299
26.4 Register Descriptions .....	300
<b>Chapter 27. External I/O Control</b>	<b>303</b>
27.1 Overview .....	303
27.1.1 External I/O Bus .....	303
27.1.2 I/O Stobes .....	304
27.1.3 I/O Handshake .....	305
27.1.4 Block Diagram .....	306
27.1.5 Registers .....	306
27.2 Dependencies .....	307
27.2.1 I/O Pins .....	307
27.2.2 Clocks .....	307
27.2.3 Other Registers .....	307
27.2.4 Interrupts .....	307
27.3 Operation .....	308
27.3.1 External I/O Bus .....	308
27.3.2 I/O Stobes .....	308
27.3.3 I/O Handshake .....	308
27.4 Register Descriptions .....	309
<b>Chapter 28. Breakpoints</b>	<b>319</b>
28.1 Overview .....	319
28.1.1 Block Diagram .....	320
28.1.2 Registers .....	321
28.2 Dependencies .....	322
28.2.1 I/O Pins .....	322
28.2.2 Clocks .....	322
28.2.3 Other Registers .....	322
28.2.4 Interrupts .....	322
28.3 Operation .....	322
28.3.1 Handling Interrupts .....	322
28.3.2 Example ISR .....	323
28.4 Register Descriptions .....	324

<b>Chapter 29. Low-Power Operation</b>	<b>327</b>
29.1 Overview .....	327
29.1.1 Registers .....	328
29.2 Operation .....	329
29.2.1 Unused Pins .....	329
29.2.2 Clock Rates .....	329
29.2.3 Short Chip Selects .....	330
29.2.4 Self-Timed Chip Selects .....	335
29.3 Register Descriptions .....	336
<b>Chapter 30. System/User Mode</b>	<b>339</b>
30.1 Overview .....	339
30.1.1 Registers .....	340
30.2 Dependencies .....	341
30.2.1 I/O Pins .....	341
30.2.2 Clocks .....	341
30.2.3 Other Registers .....	341
30.2.4 Interrupts .....	342
30.3 Operation .....	343
30.3.1 Memory Protection Only .....	343
30.3.2 Mixed System/User Mode Operation .....	344
30.3.3 Complete Operating System .....	344
30.3.4 Enabling the System/User Mode .....	345
30.3.5 System/User Mode Instructions .....	346
30.3.6 System Mode Violation Interrupt .....	347
30.3.7 Handling Interrupts in the System/User Mode .....	348
30.4 Register Descriptions .....	350
<b>Chapter 31. Specifications</b>	<b>357</b>
31.1 DC Characteristics .....	357
31.2 AC Characteristics .....	359
31.3 Memory Access Times .....	360
31.3.1 Memory Reads .....	360
31.3.2 Memory Writes .....	360
31.3.3 External I/O Reads .....	363
31.3.4 External I/O Writes .....	363
31.3.5 Memory Access Times .....	365
31.4 Clock Speeds .....	368
31.4.1 Recommended Clock/Memory Configurations .....	368
31.5 Power and Current Consumption .....	372
31.5.1 Sleepy Mode Current Consumption .....	373
31.5.2 Battery-Backed Clock Current Consumption .....	374
<b>Chapter 32. Package Specifications and Pinout</b>	<b>375</b>
32.1 Ball Grid Array Packages .....	375
32.1.1 Pinout 17 × 17 Ethernet Option .....	375
32.1.2 Pinout 17 × 17 Wi-Fi Option .....	376
32.1.3 Mechanical Dimensions and Land Pattern .....	377
32.2 Rabbit Pin Descriptions .....	379
<b>Appendix A. Parallel Port Pins with Alternate Functions</b>	<b>383</b>
A.1 Alternate Parallel Port Pin Outputs .....	383
A.2 Alternate Parallel Port Pin Inputs .....	385
<b>Index</b>	<b>387</b>

# 1. THE RABBIT 5000 PROCESSOR

## 1.1 Introduction

Rabbit Semiconductor was formed expressly to design a better microprocessor for use in small- and medium-scale single-board computers. The first microprocessors were the *Rabbit 2000*, *Rabbit 3000*, and the *Rabbit 4000*. The latest microprocessor is the *Rabbit 5000*. Rabbit microprocessor designers have had years of experience using Z80, Z180, and HD64180 microprocessors in small single-board computers. The Rabbit microprocessors share a similar architecture and a high degree of compatibility with these microprocessors, but represent a vast improvement.

The Rabbit 5000 is a high-performance microprocessor with low electromagnetic interference (EMI), and is designed specifically for embedded control, communications, and network connectivity. Extensive integrated features and glueless architecture facilitate rapid hardware design, while a C-friendly instruction set promotes efficient development of even the most complex applications.

The Rabbit 5000 is the first Rabbit microprocessor to have a full 16-bit internal bus architecture, providing significant performance improvements when used with external 16-bit memory devices. It also has the ability to support both 8-bit and 16-bit external memory devices.

The Rabbit 5000 is also the fastest microprocessor from Rabbit, now a Digi International brand, running at up to 100 MHz, with compact code and support for up to 16 MB of memory. Operating with a 1.8 V core and 3.3 V I/O, the Rabbit 5000 boasts eight channels of DMA, six serial ports with IrDA, 48+ digital I/O, quadrature decoder, PWM outputs, and pulse capture and measurement capabilities. It also features a battery-backable real-time clock, glueless memory and I/O interfacing, and ultra-low power modes. Four levels of interrupt priority allow fast response to real-time events. Its compact instruction set and high clock speeds give the Rabbit 5000 exceptionally fast math, logic, and I/O performance.

The Rabbit 5000 contains 128 KB of internal high-speed 16-bit SRAM, which can be used for code and/or data. It is capable of booting off of a standard serial flash, so a microcontroller application with no external parallel memory is possible.

The Rabbit 5000 provides two options for network connectivity — a full 10/100Base-T Ethernet MAC with a standard MII PHY interface, and a wireless 802.11b/g MAC compatible with several standard Wi-Fi transceivers. The two network interfaces share both internal resources and I/O pins, and so only one can be enabled at a time.

## 1.2 Features

The Rabbit 5000 has several powerful design features that practically eliminate EMI problems, which is essential for OEMs who need to pass CE and regulatory radio-frequency emissions tests. The amplitude of any electromagnetic radiation is reduced by the internal spectrum spreader, by gated clocks (which prevent unnecessary clocking of unused registers), and by separate power planes for the processor core and I/O pins (which reduce noise crosstalk). An external I/O bus can be used by designers to enable separate buses for I/O and memory, or to limit loading the memory bus to reduce EMI and ground bounce problems when interfacing external peripherals to the processor. The external I/O bus accomplishes this by duplicating the Rabbit's data bus on Parallel Port A, and uses Parallel Port B to provide the processor's six or eight least significant address lines for interfacing with external peripherals.

The high-performance instruction set offers both greater efficiency and execution speed of compiler-generated C code. Instructions include numerous single-byte opcodes that execute in two clock cycles, 16-bit and 32-bit loads and stores, 16-bit and 32-bit logical and arithmetic operations,  $16 \times 16$  multiply (executes in 12 clocks), long jumps and returns for accessing a full 16 MB of memory, and one-byte prefixes to turn memory-access instructions into internal and external I/O instructions. Hardware-supported breakpoints ease debugging by trapping on code execution or data reads and writes.

The Rabbit 5000 requires no external memory driver or interface-logic. Its 24-bit address bus, 8-bit or 16-bit data bus, three chip-select lines, two output-enable lines, and two write-enable lines can be interfaced directly with up to six memory devices. Up to 1 MB of memory can be accessed directly via the Dynamic C development software, and up to 16 MB can be interfaced with additional software development. The Rabbit 5000 also contains 128 KB of internal high-speed 16-bit SRAM, which can be used in addition to any external memory devices.

A built-in slave port allows the Rabbit 5000 to be used as master or slave in multi-processor systems, permitting separate tasks to be assigned to dedicated processors. An 8-line data port and five control signals simplify the exchange of data between devices. A remote cold boot enables startup and programming via a serial port, a slave port, or from a standard external serial flash device.

The Rabbit 5000 features six 8-bit parallel ports, yielding a total of 48 digital I/O. Six CMOS-compatible serial ports are available. All six are configurable as asynchronous (including output pulses in IrDA format), while four are configurable as clocked serial (SPI) and two are configurable as SDLC/HDLC. The various internal peripherals share the parallel port's I/O pins.

The Rabbit 5000 also offers many specialized peripherals. Two input-capture channels each have a 16-bit counter, clocked by the output of an internal timer, that can be used to capture and measure pulses. These measurements can be extended to a variety of functions such as measuring pulse widths or for baud-rate autodetection. Two Quadrature Decoder channels each have two inputs, as well as an 8- or 10-bit up/down counter. Each quadrature

decoder channel provides a direct interface to optical encoder units. Four independent pulse-width modulator (PWM) outputs, each based on a 1024-pulse frame, are driven by the output of a programmable internal timer. The PWM outputs can be filtered to create a 10-bit D/A converter or they can be used directly to drive devices such as motors or solenoids. Two external interrupt vectors can multiplex inputs from up to six external pins.

The Rabbit 5000 has three timer systems. Timer A consists of ten 8-bit counters, each of which has a programmed time constant. Six of them can be cascaded from the primary Timer A counter. Timer B contains a 10-bit counter, two match registers, and two step registers. An interrupt can be generated or the output pin can be updated when the counter reaches a match value, and the match value can then be incremented automatically by the step value. Timer C is a 16-bit counter that counts up to a programmable limit. It contains eight match registers so that up to four PWM (both synchronous and variable-phase) or quadrature decoder signals can be created.

The Rabbit 5000 also provides support for protected operating systems. Support for two levels of operation, known as *system* and *user* modes, allow application-critical code to operate in safety while user code is prevented from inadvertently disturbing the setup of the processor. Memory blocks as small as 4 KB can be write-protected against accidental writes by user code, and stack over/underflows can be trapped by high-priority interrupts.

Security features are also available in the Rabbit 5000. Portions of the new instruction set were introduced to increase encryption algorithm speeds dramatically, and 32 bytes of battery-backed RAM can store an encryption key away from prying eyes.

The Rabbit 5000 supports eight channels of DMA access to internal or external memory, internal I/O addresses, and the external I/O bus. Directing a DMA channel to or from an internal peripheral such as a serial port or the Ethernet port automatically connects DMA enable signals. Burst size, priority, and guaranteed cycles for the processor are all under program control.

The Rabbit 5000 contains an 802.11b/g wireless MAC peripheral, also designed to operate with the DMA peripheral. It includes support for all standard Wi-Fi features, including infrastructure and ad-hoc modes. The high-speed internal A/D converter and D/A converter and clocked-serial control port provide a generic interface to several common Wi-Fi transceivers. A low-speed A/D converter is also available to monitor the transmit signal strength if desired. The two A/D converters and single D/A converter are available for customer use when the Wi-Fi peripheral is disabled.

The Rabbit 5000 also contains a full-featured 10/100Base-T Ethernet MAC peripheral. Designed to operate with the DMA peripheral, the Ethernet peripheral is fully compliant with the 802.3 Ethernet standard, including support for auto-negotiation, link detection, multicast filtering, and broadcast addresses. An industry-standard MII interface is used to connect to an external PHY device.

### 1.3 Block Diagram

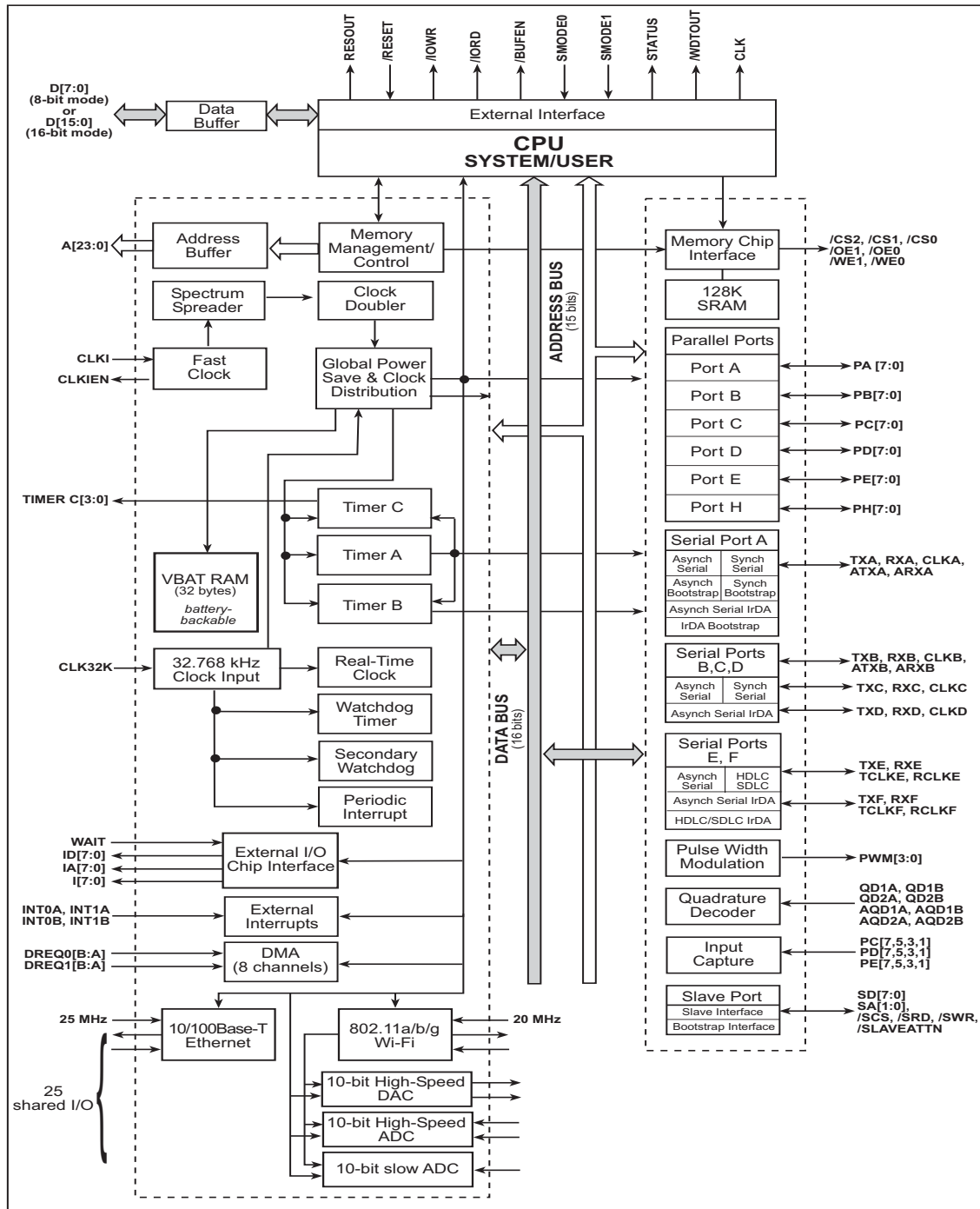

## 1.4 Basic Specifications

Two versions of the Rabbit 5000 are available—the standard 289-ball BGA and a compact 196-ball BGA for specialty Wi-Fi applications. The larger package is intended for most Rabbit applications; the smaller package has specific features and limitations, and is not presently offered for sale. If you need further information, please contact your Rabbit sales representative.

**Table 1-1. Rabbit 5000 Specifications and Features**

Package	289-ball BGA	196-ball BGA
Package Size	15 mm × 15 mm × 1.4 mm	12 mm × 12 mm × 1.2 mm
Operating Voltage	1.8 V DC core, 3.3 V DC I/O ring	
Operating Current	0.57 mA/MHz @ 1.8 V/3.3 V (Wi-Fi and Ethernet disabled)	
Operating Temp.	-40°C to +85°C	
Maximum Clock Speed	100 MHz	
Digital I/O	48+ (arranged in six 8-bit ports)	19
Network Interfaces	10/100Base-T 802.11b/g Wi-Fi	802.11b/g Wi-Fi
Serial Ports	6 CMOS-compatible	2 CMOS-compatible
Baud Rate	Clock speed/8 max. asynchronous	
Address Bus	20/24-bit	8-bit
Data Bus	8/16-bit	8/16-bit
Timers	Ten 8-bit, one 10-bit with 2 match registers, and one 16-bit with 8 match registers	
Real-Time Clock	Yes, battery-backable	
RTC Oscillator Circuitry	External	
Watchdog Timer/Supervisor	Yes	
Clock Modes	1×, 2×, /2, /3, /4, /6, /8	
Power-Down Modes	Sleepy (32 kHz) Ultra-Sleepy (16, 8, 2 kHz)	
External I/O Bus	8 data, 8 address lines	No
A/D Converters	10-bit, 2 synchronous channels, up to 40 megasamples/s 10-bit, single channel, up to 300 ksamples/s	
D/A Converters	10-bit, 2 synchronous channels, up to 40 megasamples/s	

## 1.5 Comparing Rabbit Microprocessors

The Rabbit 2000, Rabbit 3000, Rabbit 4000, and Rabbit 5000 features are compared below.

Feature	Rabbit 5000	Rabbit 4000	Rabbit 3000	Rabbit 2000
Maximum Clock Speed, industrial	100 MHz	60 MHz	55.5 MHz	30 MHz
Maximum Clock Speed, commercial	100 MHz	60 MHz	58.8 MHz	30 MHz
Maximum Crystal Frequency Main Oscillator (may be doubled internally up to maximum clock speed)	100 MHz	60 MHz	30 MHz	30 MHz
32.768 kHz Crystal Oscillator	External	External	External	Internal
Operating Voltage, core	1.8 V $\pm$ 10%	1.8 V $\pm$ 10%	3.3 V $\pm$ 10%	5.0 V $\pm$ 10%
Operation Voltage, I/O	3.3 V $\pm$ 10%	3.3 V $\pm$ 10%		
Maximum I/O Input Voltage	3.6 V	3.6 V	5.5 V	5.5 V
Current Consumption	0.57 mA/MHz @ 1.8 V/3.3 V (Wi-Fi and Ethernet disabled)	0.35 mA/MHz @ 3.3 V	2 mA/MHz @ 3.3 V	4 mA/MHz @ 5 V
Number of Package Pins	289/196	128	128	100
Size of Package, LQFP/PQFP	N/A	16 $\times$ 16 $\times$ 1.5 mm	16 $\times$ 16 $\times$ 1.5 mm	24 $\times$ 18 $\times$ 3 mm
Spacing Between Package Pins		0.4 mm (16 mils)	0.4 mm (16 mils)	0.65 mm (26 mils)
Size of Package, BGA (mm)	15 $\times$ 15 $\times$ 1.4	10 $\times$ 10 $\times$ 1.2	10 $\times$ 10 $\times$ 1.2	Not available
Spacing Between Package Pins	12 $\times$ 12 $\times$ 1.2	0.8 mm	0.8 mm	
	0.8 mm			
Separate Power and Ground for I/O Buffers (EMI reduction)	Yes	Yes	Yes	No
Clock Spectrum Spreader	Yes	Yes	Yes	Rabbit 2000B/C
Clock Modes	1 $\times$ , 2 $\times$ , /2, /3, /4, /6, /8	1 $\times$ , 2 $\times$ , /2, /3, /4, /6, /8	1 $\times$ , 2 $\times$ , /2, /3, /4, /6, /8	1 $\times$ , 2 $\times$ , /4, /8
Powerdown Modes, sleepy	32 kHz	32 kHz	32 kHz	32 kHz
Powerdown Modes, ultra sleepy	16, 8, 4, 2 kHz	16, 8, 4, 2 kHz	16, 8, 4, 2 kHz	
Low-Power Memory Control	Short and Self-Timed Chip Selects	Short and Self-Timed Chip Selects	Short and Self-Timed Chip Selects	None
Extended Memory Timing for High-Frequency Operation	Yes	Yes	Yes	No
Number of 8-bit I/O Ports	6	5	7	5



<b>Feature</b>	<b>Rabbit 5000</b>	<b>Rabbit 4000</b>	<b>Rabbit 3000</b>	<b>Rabbit 2000</b>
Auxiliary I/O Data/Address Bus	Yes	Yes	Yes	None
Number of Serial Ports	6	6	6	4
Serial Ports Capable of SPI/ Clocked Serial	4 (A, B, C, D)	4 (A, B, C, D)	4 (A, B, C, D)	2 (A, B)
Serial Ports Capable of SDLC/ HDLC	2 (E, F)	2 (E, F)	2 (E, F)	None
Asynch Serial Ports With Support for IrDA Communication	6	6	6	None
Serial Ports with Support for SDLC/HDLC IrDA Communication	2	2	2	None
Maximum Asynchronous Baud Rate	Clock Speed/8	Clock Speed/8	Clock Speed/8	Clock Speed/32
Ethernet Port	10/100Base-T	10Base-T	None	None
Wi-Fi	Yes	No	No	No
PWM Outputs	4	4	4	None
Variable-Phase PWM Outputs (PPM)	4	4	None	None
Input Capture Units	2	2	2	None
Quadrature Decoders	2 channels	2 channels	2 channels	None





## 2. CLOCKS

### 2.1 Overview

The Rabbit 5000 supports up to three separate clocks at once—the main clock, the 32 kHz clock, and the 20 MHz Wi-Fi clock. The main clock is used to drive the processor clock and the peripheral clock inside the processor. The 32 kHz clock is used to drive the asynchronous serial bootstrap, the real-time clock, the periodic interrupt, and the watchdog timers.

The Rabbit 5000 has a spectrum spreader on the main clock that shortens and lengthens clock cycles. This has the net effect of reducing the peak energy of clock harmonics by spreading the spectral energy into nearby frequencies, which reduces EMI and facilitates government-mandated EMI testing. Gated clocks are used whenever possible to avoid clocking unused portions of the processor, and separate power-supply pins for the core and I/O ring further reduce EMI from the Rabbit 5000.

The main clock can be doubled or divided by 2, 4, 6, or 8 to reduce EMI and power consumption. The 32 kHz clock (which can be divided by 2, 4, 8, or 16) can be used instead of the main clock to generate processor and peripheral clocks as low as 2 kHz for significant power savings. Note that dividing the 32 kHz clock only affects the processor and peripheral clocks; the full 32 kHz signal is still provided to the real-time clock and watchdog timer peripherals that use it directly. The periodic interrupt is disabled automatically since there is not enough time to process it when running off the 32 kHz clock.

There is also a 25 MHz Ethernet clock that is provided to the external PHY chip if you are using the Ethernet option, but this Ethernet clock is not applied directly to the Rabbit 5000. The Ethernet clock can be driven by the processor clock, the processor clock divided by 2, or by the input on PE6. The Ethernet clock needs to be 25 MHz to conform to the 10/100Base-T specification. See Chapter 22 for more details on the Ethernet clock.

## 2.1.1 Block Diagram

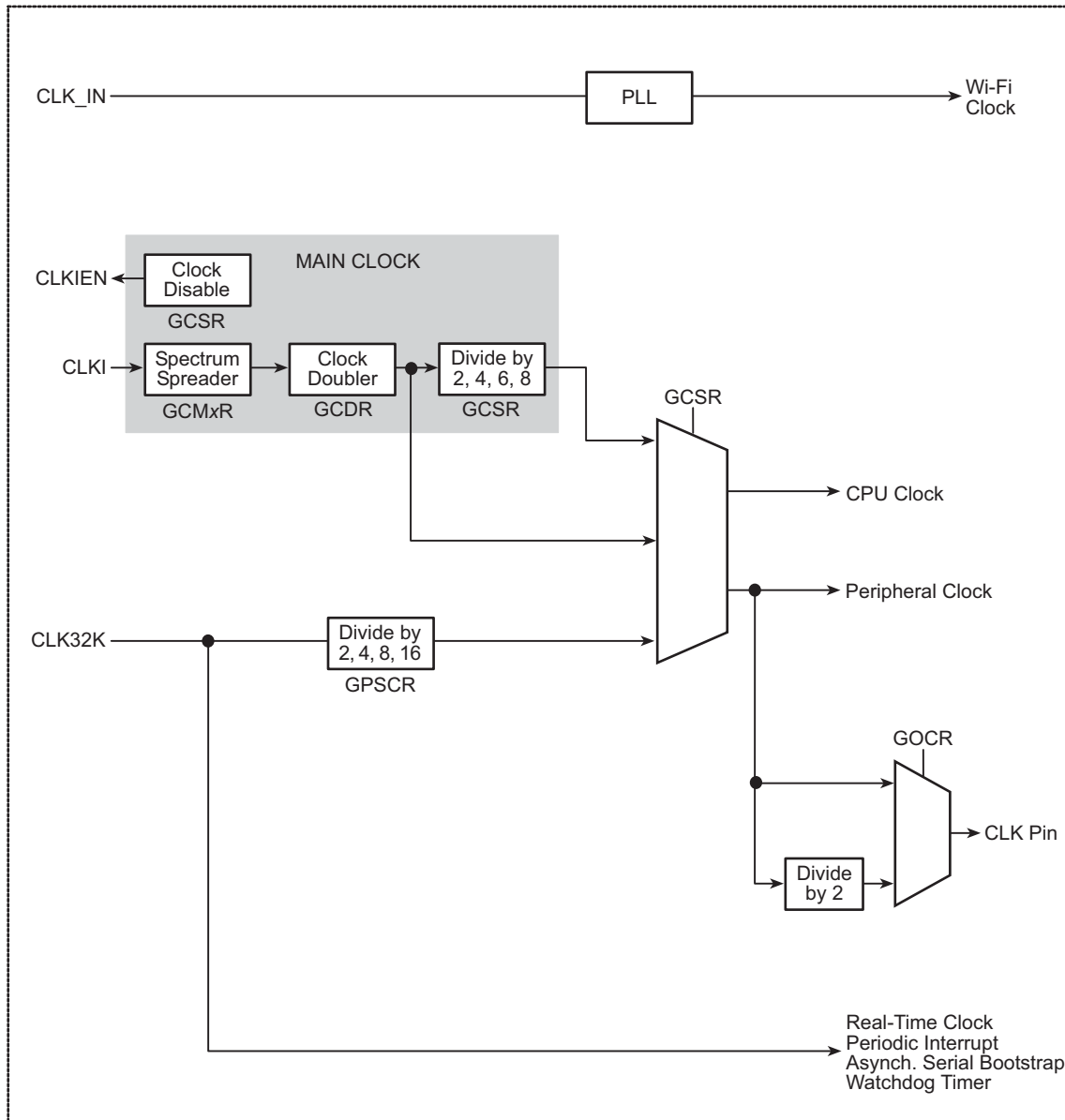

## 2.1.2 Registers

Register Name	Mnemonic	I/O Address	R/W	Reset
Global Control/Status Register	GCSR	0x0000	R/W	11000000
Global Clock Modulator 0 Register	GCM0R	0x000A	W	00000000
Global Clock Modulation 1 Register	GCM1R	0x000B	W	00000000
Global Clock Double Register	GCDR	0x000F	R/W	00000000

## 2.2 Dependencies

### 2.2.1 I/O Pins

The main clock input is on the CLKI pin. There is an internal Schmitt trigger on this pin to mitigate any noise problems associated with slowly transitioning signals.

The main clock disable output is on the CLKIEN pin. Its state is changed by one of the bit combinations of bits 4:2 in GCSR. The CLKIEN pin will output low to disable an external main oscillator when the 32 kHz mode with main oscillator disabled is selected, and will output high for all other clock modes

The 32 kHz clock input is on the CLK32K pin. There is an internal Schmitt trigger on this pin as well.

The peripheral clock or peripheral clock divided by 2 may be optionally output on the CLK pin by enabling it via bits 7:6 in GOCR.

The 20 MHz Wi-Fi clock input is located on the CLK\_IN pin; a PLL multiplies clocks up to the 80 MHz required for the Wi-Fi peripheral.

### 2.2.2 Other Registers

Register	Function
GOCR	Used to set up the CLK output pin.

## 2.3 Operation

### 2.3.1 Main Clock

The main clock is input on the CLKI pin, and is optionally sent through the spectrum spreader and then the clock doubler. Both of these are described in greater detail below.

Different main clock modes may be selected via the GCSR, as shown in Table 2-1. Note that one GCSR setting slows the processor clock while the peripheral clock operates at full speed; this allows some power reduction while keeping settings like serial baud rates and the PWM at their desired values.

**Table 2-1. Clock Modes**

GCSR Setting	Processor Clock	Peripheral Clock
xxx010xx	Main clock	Main clock
xxx011xx	Main clock / 2	Main clock / 2
xxx110xx	Main clock / 4	Main clock / 4
xxx111xx	Main clock / 6	Main clock / 6
xxx000xx	Main clock / 8	Main clock / 8 (default on startup)
xxx001xx	Main clock / 8	Main clock
xxx100xx	32 kHz clock (possibly divided)	32 kHz clock (possibly divided via GPSCR)
xxx101xx	32 kHz clock (possibly divided); main clock disabled via CLKIEN output signal	32 kHz clock (possibly divided via GPSCR)

When the 32 kHz clock is enabled in GCSR, it can be further divided by 2, 4, 6, or 8 to generate even lower frequencies by enabling those modes in bits 0–2 of GPSCR. See Table 2-4 for more details.

### 2.3.2 Spectrum Spreader

When enabled, the spectrum spreader stretches and compresses the main clock in a complex pattern that spreads the energy of the clock harmonics over a wider range of frequencies.

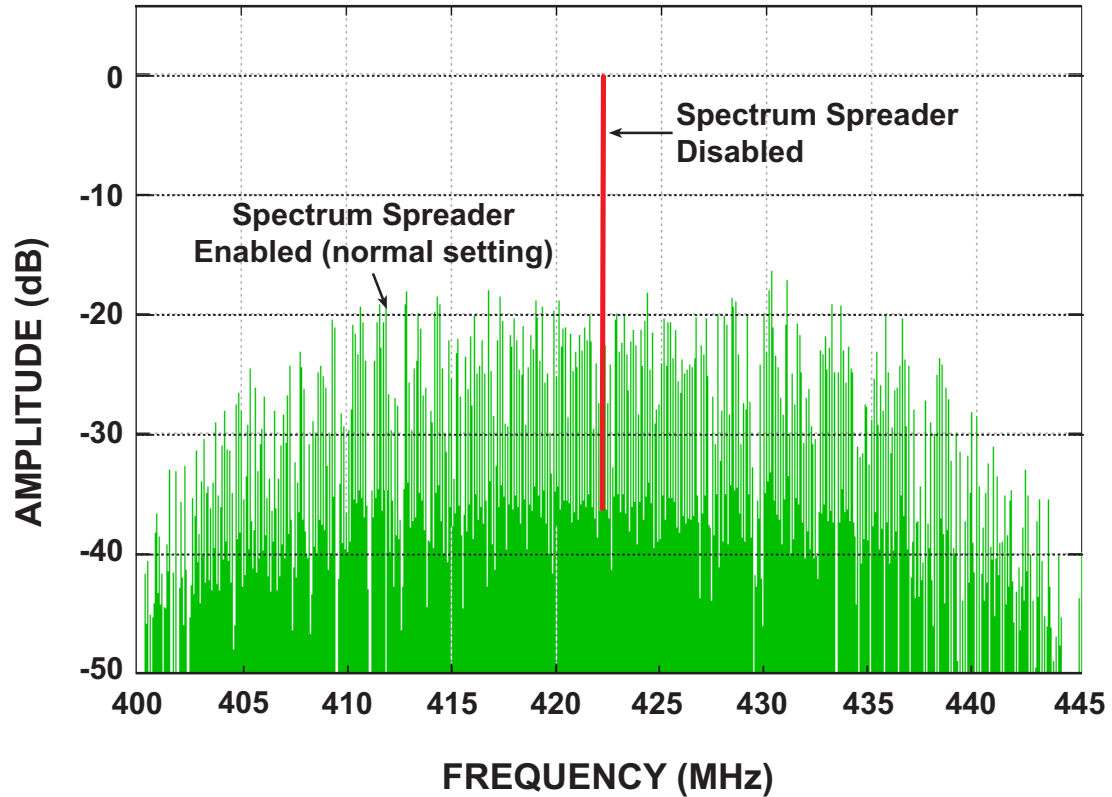

**Figure 2-1. Effects of Spectrum Spreader**

There are three settings that correspond to normal and strong spreading in the 0–50 MHz and >50 MHz main clock range. Each setting will affect the clock cycle differently; the maximum cycle shortening (at 1.8 V and 25°C) is shown in Table 2-2 below.

**Table 2-2. Spectrum Spreader Settings**

0–50 MHz	> 50 MHz	GCM0R Value	Description	Max. Cycle Shortening
—	Normal	0x40	Normal spreading of frequencies over 50 MHz	2.3 ns
Normal	Strong	0x00	Normal spreading of frequencies up to 50 MHz; strong spreading of frequencies over 50 MHz	3 ns
Strong	—	0x80	Strong spreading of frequencies up to 50 MHz; normal spreading of frequencies over 50 MHz	4.5 ns

The spectrum spreader either stretches or shrinks the low plateau of the clock by a maximum of 3 ns for the normal spreading and up to 4.5 ns for the strong spreading. If the clock doubler is used, this will cause an additional asymmetry between alternate clock cycles.

Both normal and strong modes reduce clock harmonics by approximately 15 dB for frequencies above 100 MHz; for lower frequencies the strong setting has a greater effect in reducing the peak spectral strength as shown in Figure 2-2.

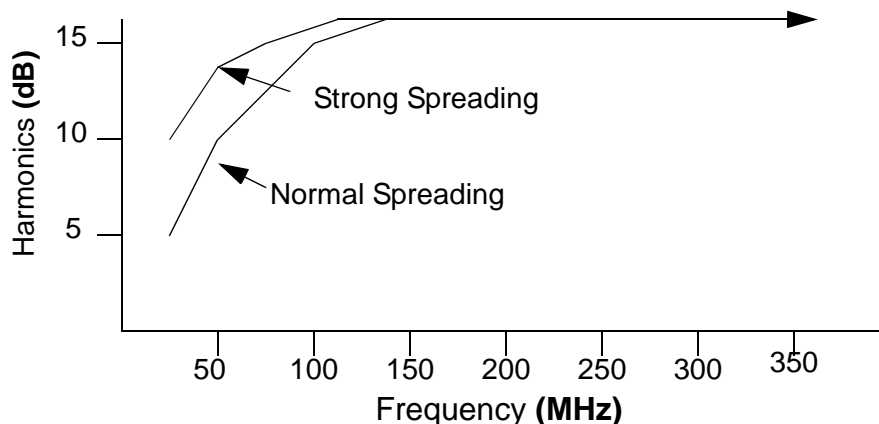

**Figure 2-2. Peak Spectral Amplitude Reduction by Spectrum Spreader**

Two registers control the clock spectrum spreader. These registers must be loaded in a specific manner with proper time delays. GCM0R is only read by the spectrum spreader at the moment when the spectrum spreader is enabled by storing 0x080 in GCM1R. If GCM1R is cleared (when disabling the spectrum spreader), there is up to a 500-clock delay before the spectrum spreader is actually disabled. The proper procedure is to clear GCM1R, wait for 500 clocks, set GCM0R, and then enable the spreader by storing 0x080 in GCM1R.

The spectrum spreader is applied to the main clock before the clock doubler, so if both are enabled there will be additional asymmetry between alternate clock cycles. If the clock doubler is used, the spectrum spreader affects every other cycle and reduces the clock high time. If the doubler is not used, then the spreader affects every clock cycle, and the clock low time is reduced.



### 2.3.3 Clock Doubler

The clock doubler allows a lower frequency crystal to be used for the main oscillator and to provide an added range over which the clock frequency can be adjusted. The clock doubler is controlled via the Global Clock Double Register (GCDR).

The clock doubler uses an on-chip delay circuit that must be programmed by the user at startup if there is a need to double the clock. Table 2-3 lists the recommended delays in GCDR for various oscillator or crystal frequencies.

**Table 2-3. Recommended Delays Set In GCDR for Clock Doubler**

Recommended GCDR Value	Frequency Range
0x0F	$\leq 7.3728$ MHz
0x0B	7.3728–11.0592 MHz
0x09	11.0592–16.5888 MHz
0x06	16.5888–20.2752 MHz
0x03	20.2752–52.8384 MHz
0x01	52.8384–77.4144 MHz
0x00	$> 77.4144$ MHz

When the clock doubler is used and there is no subsequent division of the clock, the output clock will be asymmetric, as shown in Figure 2-3.

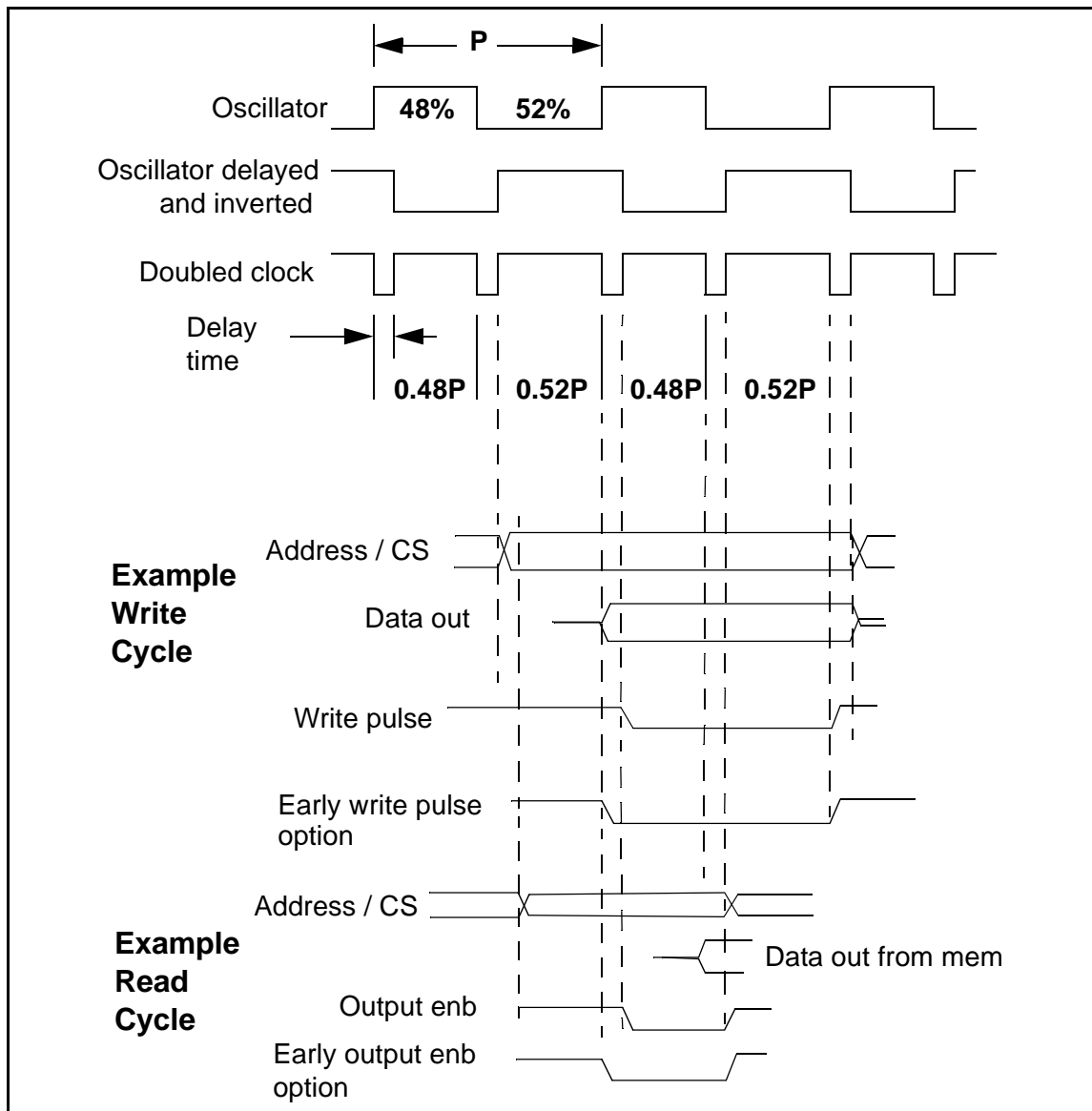

**Figure 2-3. Effect of Clock Doubler**

The doubled-clock low time is subject to wide (50%) variation since it depends on process parameters, temperature, and voltage. The times given above are for a core supply voltage of 1.8 V and a temperature of 25°C. The values increase or decrease by 1% for each 5°C increase or decrease in temperature. The doubled clock is created by xor'ing the delayed and inverted clock with itself. If the original clock does not have a 50-50 duty cycle, then alternate clocks will have a slightly different length. Since the duty cycle of the built-in oscillator can be as asymmetric as 52%/48%, the clock generated by the clock doubler will exhibit up to a 4% variation in period on alternate clocks. The memory access time is not affected because the memory bus cycle is 2 clocks long and includes both a long and a short

clock, resulting in no net change due to asymmetry. However, if an odd number of wait states is used, then the memory access time will be affected slightly

The maximum allowed clock speed must be reduced slightly if the clock is supplied via the clock doubler. The only signals clocked on the falling edge of the clock are the memory and I/O write pulses, and the early option memory output enable. See Chapter 5 for more information on the early output enable and write enable options.

The power consumption is proportional to the clock frequency, and for this reason power can be reduced by slowing the clock when less computing activity is taking place. The clock doubler provides a convenient method of temporarily speeding up or slowing down the clock as part of a power management scheme.

### 2.3.4 32 kHz Clock

The 32.768 kHz clock is used to drive the asynchronous serial bootstrap, the real-time clock, the periodic interrupt, and the watchdog timers. If these features are not used in a design, the use of the 32 kHz clock is optional.

A simplified version of the recommended oscillator circuit for the Rabbit 5000 is shown below. The values of resistors and capacitors may need to be adjusted for various frequencies and crystal load capacitances. Technical Note TN235, “External 32.768 kHz Oscillator Circuits“, is available on the Rabbit Web site and goes into this circuit in detail.

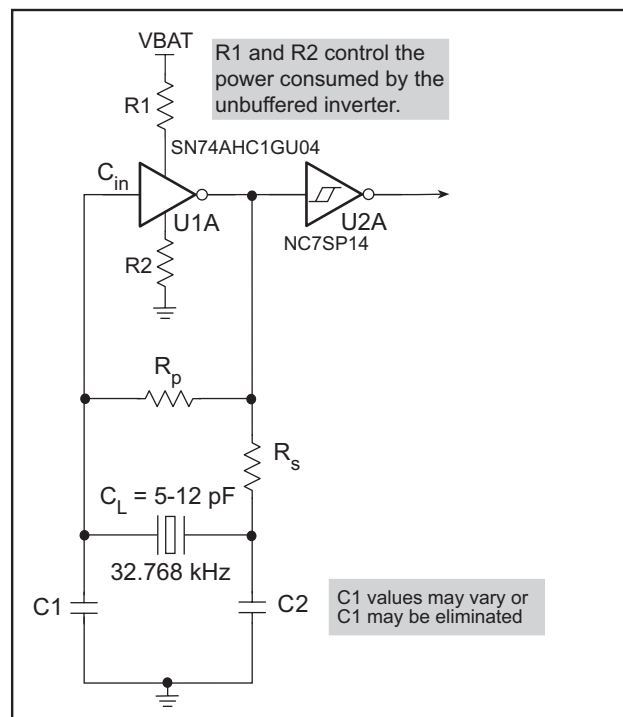

**Figure 2-4. Basic 32.768 kHz Oscillator Circuit**

The 32.768 kHz circuit consumes microampere-level currents and has a very high impedance, making it susceptible to noise, moisture, and environmental contaminants. It is strongly recommended to conformally coat this circuit to limit the effects of humidity and dust on the oscillation frequency. Details about this requirement are available in Technical Note TN303, “Conformal Coating”, from the Rabbit Web site.

The 32.768 kHz oscillator is slow to start oscillating after power-on. The startup delay may be as much as 5 seconds. For this reason, a wait loop in the BIOS waits until this oscillator is oscillating regularly before continuing the startup procedure. If the clock is battery-backed, there will be no startup delay since the oscillator is already oscillating. Crystals with low series resistance ( $R < 35 \text{ k}\Omega$ ) will start faster.

The 32 kHz oscillator can be used to drive the processor and the peripheral clock to provide significant power savings in “ultra-sleepy” modes. The 32 kHz oscillator can be divided by 2, 4, 8, or 16 to provide clock speeds as low as 2.048 kHz. Special self-timed chip selects are available to keep the memory devices enabled for as short a time as possible when an ultra-sleepy mode is enabled; see Chapter 29 for more details on reducing power consumption.

**Table 2-4. Ultra-Sleepy Clock Modes**

<b>GPSCR Setting</b>	<b>Processor and Peripheral Clock</b>
xxxxx000	32.768 kHz
xxxxx100	16.384 kHz
xxxxx101	8.192 kHz
xxxxx110	4.096 kHz
xxxxx111	2.048 kHz

When the 32 kHz clock is enabled, the periodic interrupt is disabled automatically. The real-time clock and watchdog timers keep running, and use the full 32 kHz clock speed even when the processor and peripheral clocks use a divider on the 32 kHz clock.

## 2.4 Register Descriptions

Global Control/Status Register (GCSR) (Address = 0x0000)		
Bit(s)	Value	Description
7:6 (rd-only)	00	No reset or watchdog timer timeout since the last read.
	01	The watchdog timer timed out. These bits are cleared by a read of this register.
	10	This bit combination is not possible.
	11	Reset occurred. These bits are cleared by a read of this register.
5	0	No effect on the periodic interrupt. This bit will always be read as zero.
	1	Force a periodic interrupt to be pending.
4:2	000	Processor clock from the main clock, divided by 8. Peripheral clock from the main clock, divided by 8.
	001	Processor clock from the main clock, divided by 8. Peripheral clock from the main clock.
	010	Processor clock from the main clock. Peripheral clock from the main clock.
	011	Processor clock from the main clock, divided by 2. Peripheral clock from the main clock, divided by 2.
	100	Processor clock from the 32 kHz clock, optionally divided via GPSCR. Peripheral clock from the 32 kHz clock, optionally divided via GPSCR.
	101	Processor clock from the 32 kHz clock, optionally divided via GPSCR. Peripheral clock from the 32 kHz clock, optionally divided via GPSCR. The main clock is disabled.
	110	Processor clock from the main clock, divided by 4. Peripheral clock from the main clock, divided by 4.
	111	Processor clock from the main clock, divided by 6. Peripheral clock from the main clock, divided by 6.
1:0	00	Periodic interrupts are disabled.
	01	Periodic interrupts use Interrupt Priority 1.
	10	Periodic interrupts use Interrupt Priority 2.
	11	Periodic interrupts use Interrupt Priority 3.

<b>Global Clock Modulator 0 Register (GCM0R) (Address = 0x000A)</b>		
<b>Bit(s)</b>	<b>Value</b>	<b>Description</b>
7:6	00	Clock dither in 1 ns steps, from 0 ns to 26 ns. Do not modify while the dither function is enabled.
	01	Clock dither in 0.5 ns steps, from 0 ns to 13 ns.
	10	Clock dither in 2 ns steps, from 0 ns to 52 ns.
	11	This bit combination is reserved and must not be used.
5:0		These bits are reserved and should be written with zeros.

<b>Global Clock Modulator 1 Register (GCM1R) (Address = 0x000B)</b>		
<b>Bit(s)</b>	<b>Value</b>	<b>Description</b>
7	0	Disable the clock dither function. The disable does not take effect until the dither pattern has returned to the 0 ns base delay value.
	1	Enable the clock dither function.
6:0		These bits are reserved and should be written with zeros.

<b>Global Clock Double Register (GCDR) (Address = 0x000F)</b>		
<b>Bit(s)</b>	<b>Value</b>	<b>Description</b>
7:5		These bits are reserved and should be written with zeros.
4:0	00000	The clock doubler circuit is disabled.
	00001	6 ns nominal low time.
	00010	7 ns nominal low time.
	00011	8 ns nominal low time.
	00100	9 ns nominal low time.
	00101	10 ns nominal low time.
	00110	11 ns nominal low time.
	00111	12 ns nominal low time.
	01000	13 ns nominal low time.
	01001	14 ns nominal low time.
	01010	15 ns nominal low time.
	01011	16 ns nominal low time.
	01100	17 ns nominal low time.
	01101	18 ns nominal low time.
	01110	19 ns nominal low time.
	01111	20 ns nominal low time.
	10001	3 ns nominal low time.
10010	4 ns nominal low time.	
10011	5 ns nominal low time.	
other		Any bit combination not listed is reserved and must not be used.



<b>Global Output Control Register (GOCR) (Address = 0x000E)</b>		
<b>Bit(s)</b>	<b>Value</b>	<b>Description</b>
7:6	00	CLK pin is driven with peripheral clock.
	01	CLK pin is driven with peripheral clock divided by 2.
	10	CLK pin is low.
	11	CLK pin is high.
5:4	00	STATUS pin is active (low) during a first opcode byte fetch.
	01	STATUS pin is active (low) during an interrupt acknowledge.
	10	STATUS pin is low.
	11	STATUS pin is high.
3:2	00	/WDTOUT pin functions normally.
	01	Enable /WDTOUT for test mode. Reserved for internal use only.
	10	/WDTOUT pin is low (1 cycle min, 2 cycles max, of 32 kHz).
	11	This bit combination is reserved and should not be used.
1:0	00	/BUFEN pin is active (low) during external I/O cycles.
	01	/BUFEN pin is active (low) during data memory accesses.
	10	/BUFEN pin is low.
	11	/BUFEN pin is high.





## 3. RESET AND BOOTSTRAP

### 3.1 Overview

The Rabbit 5000's /RESET pin initializes everything in the processor except for the real-time clock registers and the contents of the battery-backed onchip-encryption RAM. If a write cycle is in progress, it waits until the write cycle is completed to avoid potential memory corruption.

After reset, the Rabbit 5000 checks the state of the SMODE and SYSCFG pins. Depending on the state of the SMODE pins, it either begins normal operation by fetching instruction bytes from memory bank zero, which is mapped to either /CS0 or /CS3 depending on the state of the SYSCFG0 pin, or it enters a special bootstrap mode where it fetches bytes from either Serial Port A or the slave port. In this mode, bytes can be written to internal registers to set up the Rabbit 5000 for a particular configuration, or to memory to load a program. The processor can begin normal operation once the bootstrap operation is completed.

### 3.1.1 Block Diagram

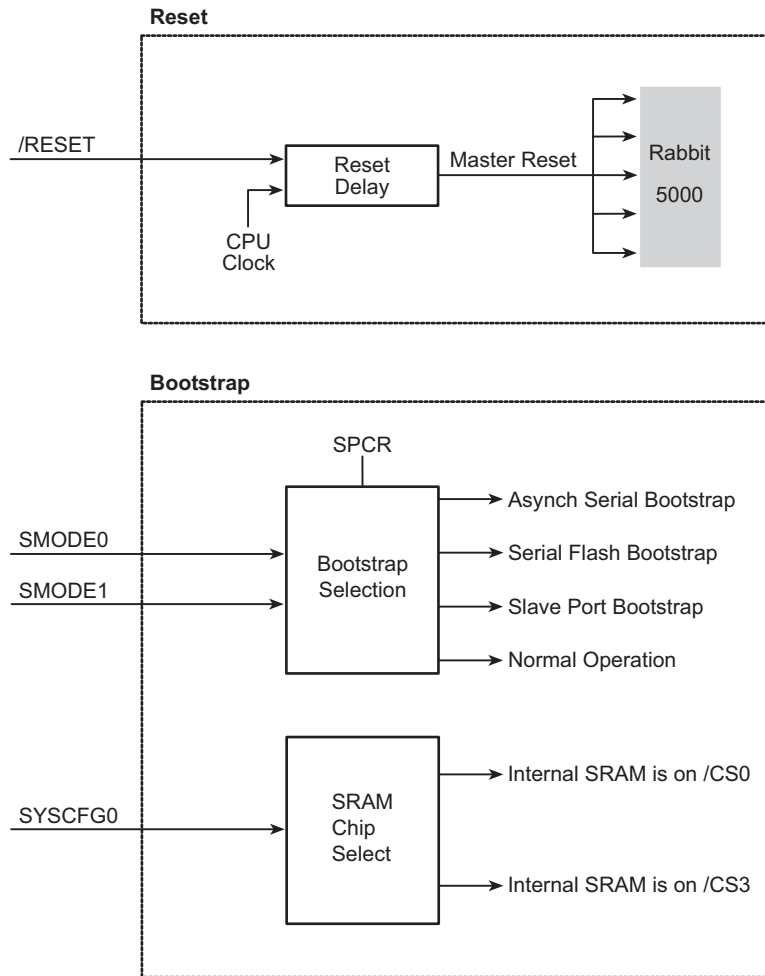

### 3.1.2 Registers

Register Name	Mnemonic	I/O Address	R/W	Reset
Slave Port Control Register	SPCR	0x0024	R/W	0xx00000

## 3.2 Dependencies

### 3.2.1 I/O Pins

SMODE0, SMODE1 — When the Rabbit 5000 is first powered up or when it is reset, the state of the SMODE0 and SMODE1 pins controls its operation.

SYSCFG0 — When the Rabbit 5000 is first powered up or when it is reset, the state of this pin controls whether memory bank zero is mapped to /CS0 or the internal SRAM (/CS3).

SYSCFG1 — This pin should always be tied to ground.

/RESET — Pulling the /RESET pin low will initialize everything in the Rabbit 5000 except for the real-time clock registers and the onchip-encryption RAM.

/CS1 — During reset the impedance of the /CS1 pin is high, and all other memory and I/O control signals are held high. The special behavior of /CS1 allows an external RAM to be powered by the same source as the VBATIO pin (which powers /CS1). In this case, a pul-lup resistor is required on /CS1 to keep the RAM deselected during powerdown.

RESOUT — The RESOUT pin, which is powered by the backup battery, is high during reset and powerdown as long as VBAT and VBATIO are present, but low at all other times, and can be used to control an external power switch to disconnect VDDIO from VBATIO when the main power source is removed.

### 3.2.2 Clocks

The processor requires a 32 kHz clock input to generate the 2400 bps internal clock required for asynchronous serial bootstrap, which is used when booting via Dynamic C and the Rabbit Field Utility. No 32 kHz clock is required for either clocked serial or slave port bootstrap.

When the processor comes out of reset, the CPU clock and peripheral clocks are both in divide-by-8 mode.

### 3.2.3 Other Registers

Register	Function
<u>SPCR</u>	Enable/disable processor monitoring of SMODE pins; read current state of SMODE pins.

### 3.2.4 Interrupts

There are no interrupts associated with reset or bootstrap.

### 3.3 Operation

Pulling the /RESET pin low will initialize everything in the Rabbit 5000 except for the real-time clock registers and the onchip-encryption RAM. The reset of the Rabbit 5000 is delayed until any write cycles in progress are completed; the reset takes effect as soon as no write cycles are occurring. The reset sequence requires a minimum of 128 cycles of the main clock to complete in either case.

During reset, the impedance of the /CS1 pin is high and all other memory and I/O control signals are held high. The special behavior of /CS1 allows an external RAM to be powered by the same source as the VBATIO pin (which powers /CS1). In this case, a pullup resistor is required on /CS1 to keep the RAM deselected during powerdown. The RESOUT pin, which is powered by the backup battery, is high during reset and powerdown as long as VBAT and VBATIO are present, but low at all other times, and can be used to control an external power switch to disconnect VDDIO from VBATIO when the main power source is removed.

Table 3-1 lists the condition of the processor after reset takes place. The state of all registers after reset is provided in the chapter describing the specific peripheral.

**Table 3-1. Rabbit 5000 Condition After Reset**

Function	Operation After Reset
CPU Clock, Peripheral Clock	Divide-by-8 mode
Clock Doubler, Clock Dither	Disabled
Memory Bank 0 Control Register	/CS0, /OE0, write-protected, 4 wait states
Memory Advanced Control Register	8-bit interface
CPU Registers: PC, SP, IIR, EIR, SU, HTR	0x0000
Interrupt Priority (IP Register)	0xFF (Priority 3)
Watchdog Timer	Enabled (2 seconds)
Secondary Watchdog Timer	Disabled

The processor checks the SMODE and SYSCFG0 pins after the /RESET signal is inactive. Table 3-2 summarizes what happens.

**Table 3-2. SMODE Pin Settings**

SMODE Pins [1,0]	SYSCFG0	Operation
00	0	No bootstrap; code is fetched from address 0x0000 on /CS0, /OE0.
00	1	No bootstrap; code is fetched from address 0x0000 on /CS3, /OE0. The internal SRAM is enabled as a 16-bit memory device.
01	x	Bootstrap from the slave port.
10	x	Bootstrap from Serial Port A, serial flash mode.
11	x	Bootstrap from Serial Port A, asynchronous mode.

If both SMODE pins are zero, the Rabbit 5000 begins fetching instructions from the memory device mapped into memory bank 0. When SYSCFG0 is low, memory bank 0 is set to /CS0 and /OE0. If SYSCFG0 is high, memory bank 0 is set to /CS3 and /OE0, and the internal SRAM is selected in 16-bit mode. If a 16-bit memory is used in memory bank 0, the first section of code must immediately select the 16-bit bus mode. Chapter 5 provides a short sample program to do this.

If either of the SMODE pins is high, the processor will enter the bootstrap mode and accept triplets from Serial Port A, the serial flash bootstrap port, or the slave port, depending on the SMODE pin selection. It is good practice to place pulldown resistors on the SMODE pins to ensure the proper operation of your design.

In the bootstrap mode, the processor inhibits the normal memory fetch, and instead fetches instructions from a small internal boot ROM. This program reads triplets of three bytes from the selected peripheral. The first byte is the most-significant byte of a 16-bit address, the second byte is the least-significant byte of the address, and the third byte is the data to be written. If the uppermost bit of the address is 1, then the address is assumed to be an internal register address instead of a memory address, and the data are written to the appropriate register instead. For example, a triplet of (0x04, 0x34, 0x5A) will write 0x5A to logical memory address 0x0434, while a triplet of (0x80, 0x34, 0x5A) will write 0x5A to processor register 0x34. Processor registers with addresses above 0xFF are not accessible in the bootstrap mode.

The boot ROM program waits for data to be available; each byte received automatically resets the watchdog timer with a 2-second timeout. Bytes must be received quickly enough to prevent timeout (or the watchdog must be disabled).

The device checks the state of the SMODE pins each time it jumps back to the start of the ROM program and responds according to the current state. In addition, by setting bit 7 of

the Slave Port Control Register (SPCR) high, the processor can be told to ignore the state of the SMODE pins and continue normal operation.

Note that the processor can be told to re-enter bootstrap mode at any time by setting bit 7 of SPCR low; once this occurs and the least significant four bits of the current PC address are zero, the processor will sample the state of the SMODE pins and respond accordingly. This feature allows in-line downloading from the selected bootstrap port; once the download is complete, bit 7 of SPCR can be set high and the processor will continue operating from where it left off.

As a security feature, any attempt to enter the bootstrap mode from either the SMODE pins or by writing to bit 7 of the SPCR will erase the data stored in the onchip-encryption RAM. This prevents loading a small program in memory to read out the data.

### 3.3.1 Asynchronous Serial Bootstrap

When the *asynchronous serial bootstrap mode* is selected by the SMODE pins, the Rabbit 5000 will be accepting triplets at 2400 bps on Serial Port A. The baud rate is generated from the 32 kHz clock input, so a 32 kHz clock is required for this mode.

### 3.3.2 Serial Flash Bootstrap

When the *serial flash bootstrap mode* is selected by the SMODE pins, the Rabbit 5000 will enable the SPI serial flash bootstrap port on pins PD4, PD5, PD6, and PB0; the pins' functionality is listed in Table 3-3 below. Note that these pins can be used for Serial Port B in normal operation, so the serial flash may use the serial port as a regular serial port if desired.

**Table 3-3. Serial Flash Bootstrap Pin Functions**

Pin	SPI Signal	Operation
PD4	MOSI	Rabbit data transmit (to serial flash)
PD5	MISO	Rabbit data receive (from serial flash)
PD6	CS	Chip select (to serial flash)
PB0	SCK	Serial clock (output to serial flash)

The Rabbit 5000 divides the main clock by 64 to provide the SPI clock for the serial flash bootstrap. Once this mode is entered, the Rabbit 5000 will send the byte sequence "0x03 0x00 0x00 0x00", which is an industry-standard command that enables continuous read mode starting at serial flash address 0x0. Figure 3-1 provides a sample timing diagram. The Rabbit 5000 will then read triplets out of the serial flash until the bootstrap mode is exited.



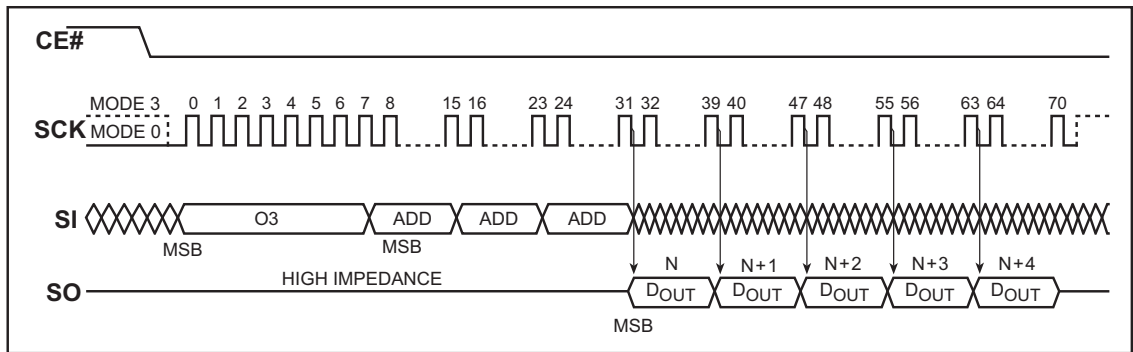

**Figure 3-1. SPI Timing Diagram for Serial Flash Bootstrap Mode**

### 3.3.3 Parallel Bootstrap

When the *parallel bootstrap mode* is selected by the SMODE pins, the Rabbit 5000 will enable the parallel slave port interface on Parallel Ports A and B, and will wait for triplets to be sent to that interface. See Chapter 19 for more details on the operation of the slave port.

### 3.4 Register Descriptions

Slave Port Control Register (SPCR) (Address = 0x0024)		
Bit(s)	Value	Description
7	0	Program fetch as a function of the SMODE pins.
	1	Ignore the SMODE pins program fetch function.
6:5	Read	These bits report the state of the SMODE pins.
	Write	These bits are ignored and should be written with zero.
4:2	000	Disable the slave port. Parallel Port A is a byte-wide input port.
	001	Disable the slave port. Parallel Port A is a byte-wide output port.
	010	Enable the slave port, with /SCS from Parallel Port E bit 7.
	011	Enable the external I/O bus. Parallel Port A is used for the data bus and Parallel Port B[7:2] is used for the address bus.
	100	This bit combination is reserved and should not be used.
	101	This bit combination is reserved and should not be used.
	110	Enable the slave port, with /SCS from Parallel Port B bit 6.
	111	Enable the external I/O bus. Parallel Port A is used for the data bus and Parallel Port B[7:0] is used for the address bus.
1:0	00	Slave port interrupts are disabled.
	01	Slave port interrupts use Interrupt Priority 1.
	10	Slave port interrupts use Interrupt Priority 2.
	11	Slave port interrupts use Interrupt Priority 3.

## 4. SYSTEM MANAGEMENT

### 4.1 Overview

There are a number of basic system peripherals in the Rabbit 5000 processor, some of which are covered in later chapters. The peripherals covered in this chapter are the periodic interrupt, the real-time clock, the watchdog timers, the battery-backed onchip-encryption RAM, and some of the miscellaneous output pins and their control and processor registers that provide the processor ID and revision numbers.

The periodic interrupt, when enabled, is generated every 16 clocks of the 32 kHz clock (every 488  $\mu$ s, or 2.048 kHz). This interrupt can be used to perform periodic tasks.

The real-time clock (RTC) consists of a 48-bit counter that is clocked by the 32 kHz clock. It is powered by the VBAT pin, and so can be battery-backed. The value in the counter is not affected by reset, and can only be set to zero by writing to the RTC control register. The 48-bit width provides a 272-year span before rollover occurs.

There are two watchdog timers in the Rabbit 5000, both clocked by the 32 kHz clock. The main watchdog timer can be set to time out from 250 ms to 2 seconds, and resets the processor if not reloaded within that time. Its purpose is to restart the processor when it detects that a program gets stuck or disabled.

The secondary watchdog timer can time out from 30.5  $\mu$ s up to 7.8 ms, and generates a Priority 3 secondary watchdog interrupt when it is not reset within that time. The primary use for the secondary watchdog is to act as a safety net for the periodic interrupt — if the secondary watchdog is reloaded in the periodic interrupt, it will count down to zero if the periodic interrupt stops occurring. In addition, it can be used as a periodic interrupt on its own.

The battery-backed onchip-encryption RAM consists of 32 bytes of memory that are powered by the VBAT pin. Their values are not affected by reset, but are erased if the state of the SMODE pins changes. These 32 bytes are intended for storing sensitive data (such as an encryption key) somewhere other than an external memory device. The “tamper-protection” erase feature prevents loading a program into the onchip-encryption RAM via the programming port and reading out the bytes.

The following other registers are also described in this chapter.

- Global Output Control Register (GOCR), which controls the behavior of the CLK, STATUS, /WDT, and /BUFEN pins
- Global CPU Register (GCPU), which holds the identification number of the processor.
- Global Revision Register (GREV), which hold the revision number of the processor.

### 4.1.1 Block Diagram

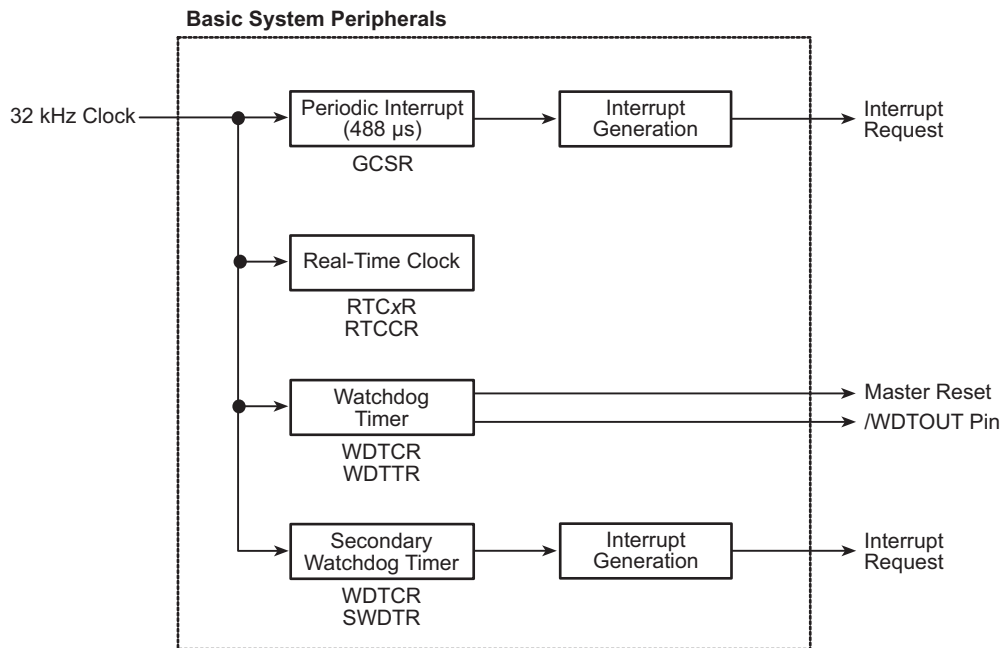

## 4.1.2 Registers

Register Name	Mnemonic	I/O Address	R/W	Reset
Global Control/Status Register	GCSR	0x0000	R/W	11000000
Real-Time Clock Control Register	RTCCR	0x0001	W	00000000
Real-Time Clock Byte 0 Register	RTC0R	0x0002	R/W	xxxxxxxx
Real-Time Clock Byte 1 Register	RTC1R	0x0003	R	xxxxxxxx
Real-Time Clock Byte 2 Register	RTC2R	0x0004	R	xxxxxxxx
Real-Time Clock Byte 3 Register	RTC3R	0x0005	R	xxxxxxxx
Real-Time Clock Byte 4 Register	RTC4R	0x0006	R	xxxxxxxx
Real-Time Clock Byte 5 Register	RTC5R	0x0007	R	xxxxxxxx
Watchdog Timer Control Register	WDTCR	0x0008	W	00000000
Watchdog Timer Test Register	WDTTR	0x0009	W	00000000
Secondary Watchdog Timer Register	SWDTR	0x000C	W	11111111
Global Output Control Register	GOCR	0x000E	R/W	00000000
Global ROM Configuration Register	GROM	0x002C	R	0xx00000
Global RAM Configuration Register	GRAM	0x002D	R	0xx00000
Global CPU Configuration Register	GCPU	0x002E	R	0xx00010
Global Revision Register	GREV	0x002F	R	0xx00000
Battery-Backed Onchip-Encryption RAM Byte 00–1F	VRAM00– VRAM1F	0x0600–0x061F	R/W	xxxxxxxx

## 4.2 Dependencies

### 4.2.1 I/O Pins

The CLK, STATUS, /WDTOUT, and /BUFEN pins are controlled by GOCR. Each of these pins can be used as general-purpose outputs by driving them high or low.

- The CLK pin can output the peripheral clock, the peripheral clock divided by two, or be driven high or low.
- The STATUS pin can be active low during the first byte of each opcode fetch, active low during an interrupt acknowledge, or driven high or low.
- The /WDTOUT pin can be active low whenever the watchdog timer resets the device or driven low.
- The /BUFEN pin can be active low during external I/O cycles, active low during data memory cycles, or driven high or low.

The values in the battery-backed onchip-encryption RAM bytes are cleared if the signal on the SMODE pins changes state.

### 4.2.2 Clocks

The periodic interrupt, real-time clock, watchdog timer, and secondary watchdog timer require the 32 kHz clock.

### 4.2.3 Interrupts

The periodic interrupt is enabled in GCSR, and will occur every 488  $\mu$ s. It is cleared by reading GCSR. It can operate at Priority 1, 2, or 3.

The secondary watchdog interrupt will occur whenever the secondary watchdog is enabled and allowed to count down to zero. It is cleared by restarting the secondary watchdog by writing to WDTCR. The secondary watchdog interrupt always occurs at Priority 3.

## 4.3 Operation

### 4.3.1 Periodic Interrupt

The following steps explain how a periodic interrupt is used.

1. Write the vector to the interrupt service routine to the internal interrupt table.
2. Enable the periodic interrupt by writing to GCSR.
3. The interrupt request is cleared by reading from GCSR.

A sample interrupt handler is shown below.

```
periodic_isr::  
    push af  
    ioi ld a, (GCSR)    ; clear the interrupt request and get status  
  
    ; handle any periodic tasks here  
  
    pop af  
    ipres  
    ret
```

### 4.3.2 Real-Time Clock

The real-time clock consists of six 8-bit registers that together comprise a 48-bit value. The real-time clock is not synchronized to the read operation, so the least-significant bit should be read twice and checked for matching values; if the two reads do not match, then the real-time clock may have been updating during the read and should be read again.

Writing to RTCOR latches the current real-time clock value into the RTCxR holding registers, so the following sequence should be used to read the real-time clock.

1. Write any value to RTCOR and then read back a value from RTCOR.
2. Write a value to RTCOR again, and again read back a value from RTCOR.
3. If the two values do not match, repeat Step 2 until the last two readings are identical.
4. At this point, registers RTC1R through RTC6R can also be read and used.

Note that the periodic interrupt and the real-time clock are clocked by the same edge of the 32 kHz clock; if read from the periodic interrupt, the count is guaranteed to be stable and only needs to be read once (assuming it occurs within one clock of the 32 kHz clock).

The real-time clock can be reset by writing the sequence 0x40 – 0x80 to RTCCR. It can be reset and left in the byte increment mode by writing 0x40 – 0xC0 to RTCCR and then writing bytes repeatedly to RTCCR to increment the appropriate bytes of the real-time clock. The byte increment mode is disabled by writing 0x00 to RTCCR.

### 4.3.3 Watchdog Timer

The watchdog timer is enabled on reset with a 2-second timeout. Unless specific data are written to WDTCR before that time expires, the processor will be reset. The watchdog timer can be disabled by writing a sequence of two bytes to WDTTR as described in the register description.

**Table 4-1. Watchdog Timer Settings**

WDTCR Value	Effect
0x5A	Restart watchdog timer with 2-second timeout.
0x57	Restart watchdog timer with 1-second timeout.
0x59	Restart watchdog timer with 500-millisecond timeout.
0x53	Restart watchdog timer with 250-millisecond timeout.
0x5F	Restart the secondary watchdog timer.

The watchdog timer also contains a special test mode that speeds up the timeout period by clocking it with the peripheral clock instead of the 32 kHz clock. This mode can be enabled by writing to WDTTR.

### 4.3.4 Secondary Watchdog Timer

The secondary watchdog timer is disabled on reset. The following steps explain how to use the secondary watchdog timer.

1. Write the vector to the interrupt service routine to the internal interrupt table.
2. Write the desired timeout period to SWDTR. This also enables the secondary watchdog timer.
3. Restart the secondary watchdog timer by either writing the timeout period to SWDTR or writing 0x5F to WDTCR.

If the secondary watchdog timer counts down to zero, a Priority 3 secondary watchdog interrupt will occur. This interrupt request is cleared by writing a new timeout value to SWDTR. A sample interrupt handler is shown below.

```
secwd_isr::
    push af

    ; determine why the interrupt occurred and take appropriate action

    ld a, 0x40          ; timeout period of 0x40/32kHz = 1.95ms
    ioi ld (SWDTR), a   ; clear the interrupt request

    pop af
    ipres
    ret
```



## 4.4 Register Descriptions

Global Control/Status Register (GCSR) (Address = 0x0000)		
Bit(s)	Value	Description
7:6 (Read-only)	00	No reset or watchdog timer timeout since the last read.
	01	The watchdog timer timed out. These bits are cleared by a read of this register.
	10	This bit combination is not possible.
	11	Reset occurred. These bits are cleared by a read of this register.
5	0	No effect on the periodic interrupt. This bit will always be read as zero.
	1	Force a periodic interrupt to be pending.
4:2	000	Processor clock from the main clock, divided by eight. Peripheral clock from the main clock, divided by eight.
	001	Processor clock from the main clock, divided by eight. Peripheral clock from the main clock.
	010	Processor clock from the main clock. Peripheral clock from the main clock.
	011	Processor clock from the main clock, divided by two. Peripheral clock from the main clock, divided by two.
	100	Processor clock from the 32 kHz clock, optionally divided via GPSCR. Peripheral clock from the 32 kHz clock, optionally divided via GPSCR.
	101	Processor clock from the 32 kHz clock, optionally divided via GPSCR. Peripheral clock from the 32 kHz clock, optionally divided via GPSCR. The main clock is disabled.
	110	Processor clock from the main clock, divided by four. Peripheral clock from the main clock, divided by four.
	111	Processor clock from the main clock, divided by six. Peripheral clock from the main clock, divided by six.
1:0	00	Periodic interrupts are disabled.
	01	Periodic interrupts use Interrupt Priority 1.
	10	Periodic interrupts use Interrupt Priority 2.
	11	Periodic interrupts use Interrupt Priority 3.

<b>Real-Time Clock Control Register (RTCCR) (Address = 0x0001)</b>		
<b>Bit(s)</b>	<b>Value</b>	<b>Description</b>
7:0	0x00	No effect on the real-time clock counter, or disable the byte increment function, or cancel the real-time clock reset command.
	0x40	Arm the real-time clock for reset or byte increment. This command must be written prior to either the real-time clock reset command or the first byte increment write.
	0x80	Reset all six bytes of the real-time clock counter to 0x00. The reset must be preceded by writing 0x40 to arm the reset function.
	0xC0	Reset all six bytes of the real-time clock counter to 0x00, and remain in byte-increment mode in preparation for setting the time.
7:6	01	This bit combination must be used with every byte-increment write.
5:0	0	No effect on the real-time clock counter.
	1	Increment the corresponding byte of the real-time clock counter.

<b>Real-Time Clock x Register (RTC0R) (Address = 0x0002) (RTC1R) (Address = 0x0003) (RTC2R) (Address = 0x0004) (RTC3R) (Address = 0x0005) (RTC4R) (Address = 0x0006) (RTC5R) (Address = 0x0007)</b>		
<b>Bit(s)</b>	<b>Value</b>	<b>Description</b>
7:0	Read	The current value of the 48-bit real-time clock counter is returned.
	Write	Writing to RTC0R transfers the current count of the real-time clock to a holding register while the real-time clock continues counting.

<b>Watchdog Timer Control Register (WDTCR) (Address = 0x0008)</b>		
<b>Bit(s)</b>	<b>Value</b>	<b>Description</b>
7:0	0x5A	Restart the watchdog timer with a 2-second timeout period.
	0x57	Restart the watchdog timer with a 1-second timeout period.
	0x59	Restart the watchdog timer with a 500 ms timeout period.
	0x53	Restart the watchdog timer with a 250 ms timeout period.
	0x5F	Restart the secondary watchdog timer.
	other	No effect on watchdog timer or secondary watchdog timer.

<b>Watchdog Timer Test Register (WDTTR) (Address = 0x0009)</b>		
<b>Bit(s)</b>	<b>Value</b>	<b>Description</b>
7:0	0x51	Clock the least significant byte of the watchdog timer from the peripheral clock.
	0x52	Clock the most significant byte of the watchdog timer from the peripheral clock.
	0x53	Clock both bytes of the watchdog timer, in parallel, from the peripheral clock.
	0x54	Disable the watchdog timer. This value, by itself, does not disable the watchdog timer. Only a sequence of two writes, where the first write is 0x51, 0x52, or 0x53, followed by a write of 0x54, actually disables the watchdog timer. The watchdog timer will be re-enabled by any other write to this register.
	other	Normal clocking (32 kHz clock) for the watchdog timer.

<b>Secondary Watchdog Timer Register (SWDTR) (Address = 0x000C)</b>		
<b>Bit(s)</b>	<b>Value</b>	<b>Description</b>
7:0		The time constant for the secondary watchdog timer is stored. This time constant will take effect the next time that the secondary watchdog counter counts down to zero. The timer counts modulo $n + 1$ , where $n$ is the programmed time constant. The secondary watchdog timer can be disabled by writing the sequence 0x5A – 0x52 – 0x44 to this register.

<b>Global ROM Configuration Register (GROM) (Address = 0x002C)</b>		
<b>Bit(s)</b>	<b>Value</b>	<b>Description</b>
7 (Read-only)	0	Program fetch as a function of the SMODE pins.
	1	Ignore the SMODE pins program fetch function.
6:5	Read	These bits report the state of the SMODE pins.
4:0	00000	ROM identifier for this version of the chip.

<b>Global RAM Configuration Register (GRAM) (Address = 0x002D)</b>		
<b>Bit(s)</b>	<b>Value</b>	<b>Description</b>
7 (Read-only)	0	Program fetch as a function of the SMODE pins.
	1	Ignore the SMODE pins program fetch function.
6:5	Read	These bits report the state of the SMODE pins.
4:0	00001	RAM identifier for this version of the chip.

<b>Global Output Control Register (GOCR) (Address = 0x000E)</b>		
<b>Bit(s)</b>	<b>Value</b>	<b>Description</b>
7:6	00	CLK pin is driven with peripheral clock.
	01	CLK pin is driven with peripheral clock divided by 2.
	10	CLK pin is low.
	11	CLK pin is high.
5:4	00	STATUS pin is active (low) during a first opcode byte fetch.
	01	STATUS pin is active (low) during an interrupt acknowledge.
	10	STATUS pin is low.
	11	STATUS pin is high.
3:2	00	/WDTOOUT pin functions normally.
	01	Enable /WDTOOUT for test mode. Reserved for internal use only.
	10	/WDTOOUT pin is low (1 cycle min, 2 cycles max, of 32 kHz).
	11	This bit combination is reserved and should not be used.
1:0	00	/BUFEN pin is active (low) during external I/O cycles.
	01	/BUFEN pin is active (low) during data memory accesses.
	10	/BUFEN pin is low.
	11	/BUFEN pin is high.

<b>Global CPU Register (GCPU) (Address = 0x002E)</b>		
<b>Bit(s)</b>	<b>Value</b>	<b>Description</b>
7 (Read-only)	0	Program fetch as a function of the SMODE pins.
	1	Ignore the SMODE pins program fetch function.
6:5	Read	These bits report the state of the SMODE pins.
4:0	00011	CPU identifier for this version of the chip.

<b>Global Revision Register (GREV) (Address = 0x002F)</b>		
<b>Bit(s)</b>	<b>Value</b>	<b>Description</b>
7 (Read-only)	0	Program fetch as a function of the SMODE pins.
	1	Ignore the SMODE pins program fetch function.
6:5	Read	These bits report the state of the SMODE pins.
4:0	00011	CPU identifier for this version of the chip.

Battery-Backed Onchip-Encryption RAM (VRAM00) through (VRAM31) (Address = 0x0600) through (Address = 0x061F)		
Bit(s)	Value	Description
7:0		General-purpose RAM locations. Cleared by Intrusion Detect conditions.





## 5. MEMORY MANAGEMENT

### 5.1 Overview

The Rabbit 5000 supports both 8-bit and 16-bit external flash and SRAM devices; three chip selects and two read/write-enable strobes allow up to six external devices to be attached at once. The 8-bit mode allows 0, 1, 2, or 4 wait states to be specified for each device, and the 16-bit mode allows 0 to 7 wait states depending on the settings. Both 8-bit and 16-bit page-mode devices are also supported.

In addition, the Rabbit 5000 contains 128 KB of internal SRAM that resides on its own chip select signal. It can be enabled in either 8- or 16-bit mode.

The Rabbit 5000's physical memory space contains four consecutive banks, each of which can be mapped to an individual chip-select/enable strobe pair. The banks can be set for equal sizes ranging from 128 KB up to 4 MB, providing a total physical memory range from 512 KB up to 16 MB. Figure 5-1 shows a sample configuration.

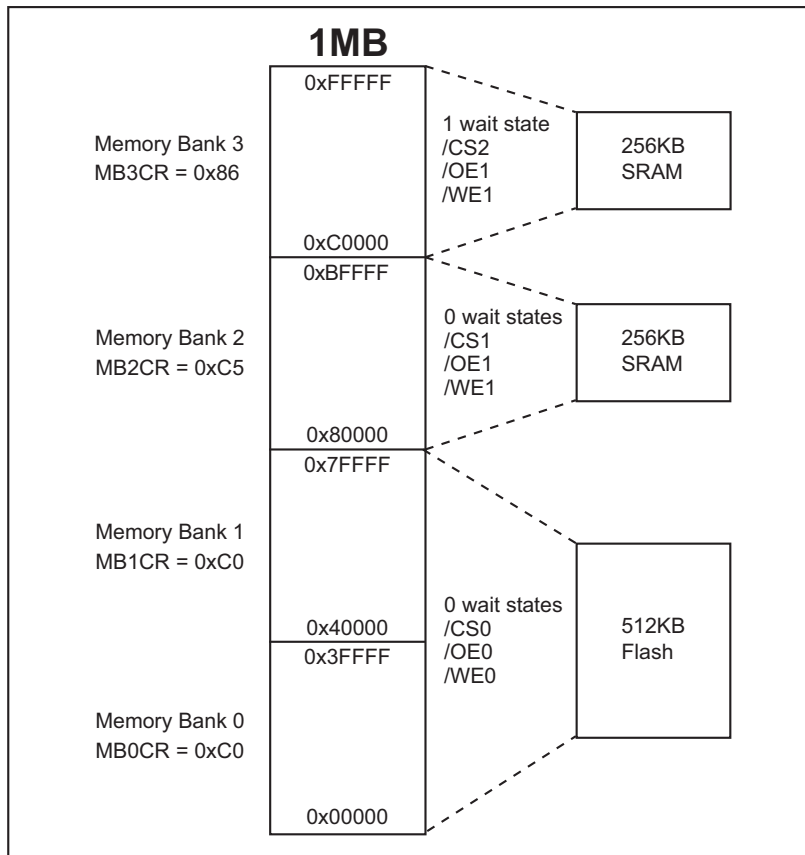

**Figure 5-1. Mapping Rabbit 5000 Physical Memory Space**

Either one or both of the two most significant address bits (which are used to select the quadrant) can be inverted, providing the ability to bank-switch other pages from a larger memory device into the same memory bank.

Code is executed in the 64 KB logical memory space, which is divided into four segments: root, data, stack, and XMEM. The root segment is mapped directly to physical address 0x000000, while the data and stack segments can be mapped to 4 KB boundaries anywhere in the physical space. The boundaries between the root and data segments and the data and stack segments can be adjusted in 4 KB blocks as well.

The XMEM segment is a fixed 8 KB, and points to a physical memory address block specified in the XPC register. It is possible to run code in the XMEM window, providing an easy means of storing and executing code beyond the 64 KB logical memory space. Special call and return instructions to physical addresses are provided that automatically update the XPC register as necessary.



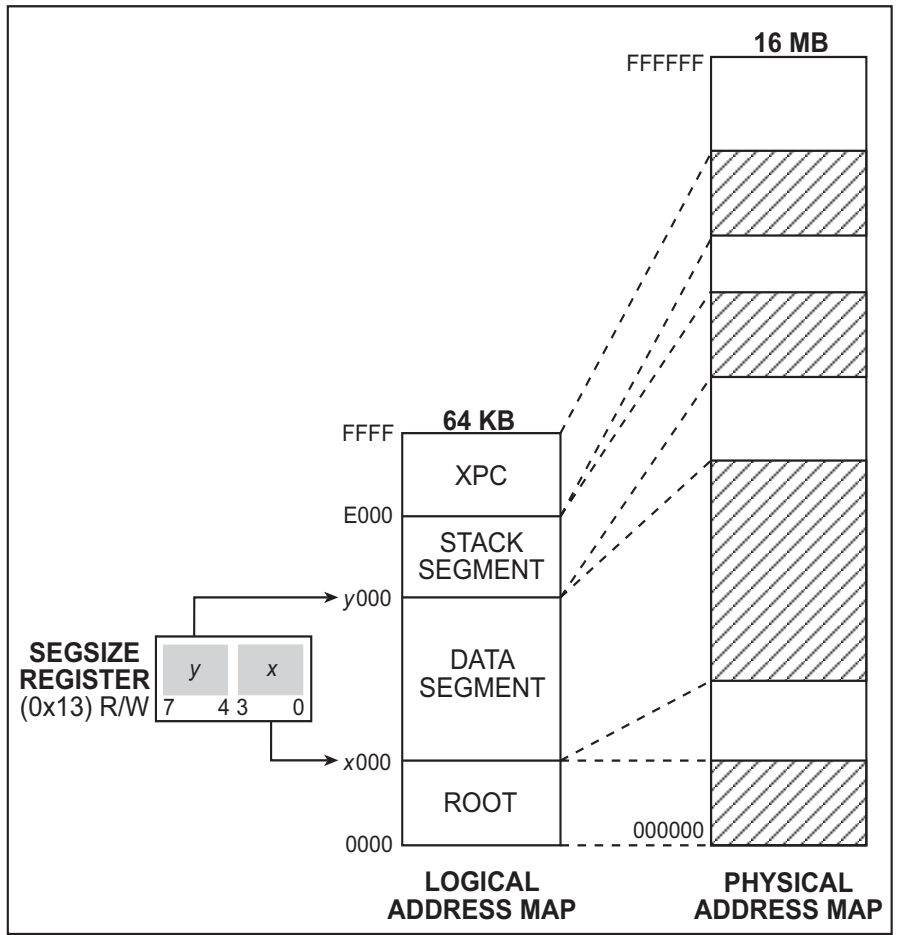

**Figure 5-2. Logical and Physical Memory Mapping**

The Rabbit 2000 and 3000 had numerous instructions for reading and writing data to logical addresses, but only had limited support for reading and writing data to a physical memory address. In the Rabbit 4000, a wide range of instructions was provided to read and write to physical addresses. The same instructions can be used to write to logical addresses. All of these instructions are available in the Rabbit 5000.

The 64 KB logical memory space limitation can also be expanded by using the separate instruction and data space mode. When this mode is enabled, address bit A16 is inverted for all data accesses in the root and/or data segments, and address bit A19 is inverted for all data accesses in the root and/or data segments *before* bank selection (physical device) occurs. These two features allow both code and data to access separate 64 KB logical spaces instead of sharing a single space.

It is possible to protect memory in the Rabbit 5000 at three different levels—each of the memory banks can be made read-only, physical memory can be write-protected in 64 KB blocks, and two of those 64 KB blocks can be protected with a granularity of 4 KB. A Priority 3 interrupt will occur if a write is attempted in one of the protected 64 KB or 4 KB blocks. In addition, it is possible to place limits around the code execution stack and generate an interrupt if a stack-related write occurs within 16 bytes of those limits.

### 5.1.1 Block Diagram

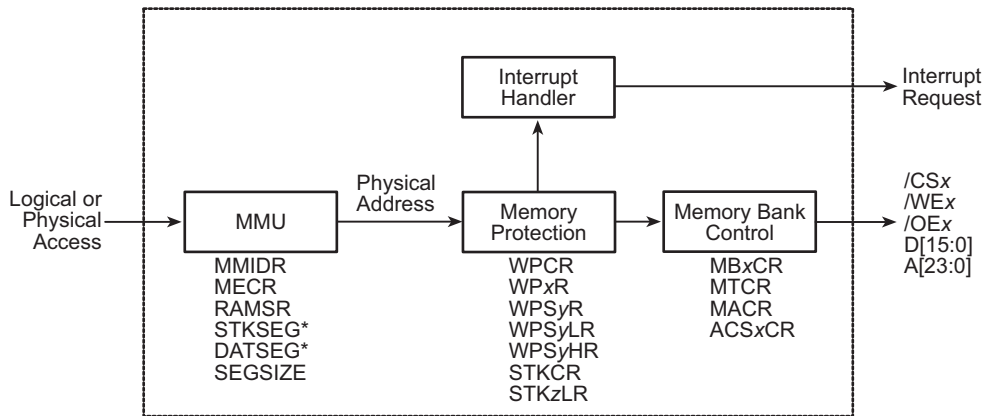

## 5.1.2 Registers

Register Name	Mnemonic	I/O Address	R/W	Reset
MMU Instruction/Data Register	MMIDR	0x0010	R/W	00000000
Stack Segment Register	STACKSEG	0x0011	R/W	00000000
Stack Segment LSB Register	STACKSEGL	0x001A	R/W	00000000
Stack Segment MSB Register	STACKSEGH	0x001B	R/W	00000000
Data Segment Register	DATSEG	0x0012	R/W	00000000
Data Segment LSB Register	DATSEGL	0x001E	R/W	00000000
Data Segment MSB Register	DATSEGH	0x001F	R/W	00000000
Segment Size Register	SEGSIZE	0x0013	R/W	11111111
Memory Bank 0 Control Register	MB0CR	0x0014	R/W	00001000
Memory Bank 1 Control Register	MB1CR	0x0015	R/W	xxxxxxxx
Memory Bank 2 Control Register	MB2CR	0x0016	R/W	xxxxxxxx
Memory Bank 3 Control Register	MB3CR	0x0017	R/W	xxxxxxxx
MMU Expanded Code Register	MECR	0x0018	R/W	00000000
Memory Timing Control Register	MTCR	0x0019	R/W	00000000
Memory Alternate Control Register	MACR	0x001D	R/W	00000000
Advanced /CS0 Control Register	ACS0CR	0x0410	R/W	00000000
Advanced /CS1 Control Register	ACS1CR	0x0411	R/W	00000000
Advanced /CS2 Control Register	ACS2CR	0x0412	R/W	00000000
RAM Segment Register	RAMSR	0x0448	R/W	00000000
Write-Protect Control Register	WPCR	0x0440	R/W	00000000
Write-Protect x Register	WPxR	0x460+x	W	00000000
Write-Protect Segment A Register	WPSAR	0x0480	W	00000000
Write-Protect Segment A Low Register	WPSALR	0x0481	W	00000000
Write-Protect Segment A High Register	WPSAHR	0x0482	W	00000000
Write-Protect Segment B Register	WPSBR	0x0484	W	00000000
Write-Protect Segment B Low Register	WPSBLR	0x0485	W	00000000
Write-Protect Segment B High Register	WPSBHR	0x0486	W	00000000
Stack Limit Control Register	STKCR	0x0444	R/W	00000000
Stack Low Limit Register	STKLLR	0x0445	W	xxxxxxxx
Stack High Limit Register	STKHLR	0x0446	W	xxxxxxxx

## 5.2 Dependencies

### 5.2.1 I/O Pins

There are three chip select pins, /CS0, /CS1, and /CS2; two read strobes, /OE0 and /OE1; and two write strobes, /WE0 and /WE1. /CS3 is available to the internal SRAM only and does not come out to a pin.

There are eight dedicated data bus pins, D0 through D7. If the 16-bit mode is enabled, then PH0–PH7 automatically act as the upper byte of the data bus, D8 through D15.

There are 20 dedicated address pins, A0 through A19. Up to four more address pins can be enabled on PE0–PE3, representing A20 through A23.

Pin PE4 can be enabled as /A0 to allow byte reads and writes in 16-bit SRAM devices.

### 5.2.2 Clocks

All memory operations are clocked by the processor clock.

### 5.2.3 Other Registers

Register	Function
PEFR, PEALR, PEAHR	Enable A20-A23 and /A0.

### 5.2.4 Interrupts

When a write is attempted to a write-protected 64 KB or 4 KB block, a write-protection violation interrupt is generated. The interrupt request is cleared when it is handled. The write-protection violation interrupt vector is in the IIR at offset 0x090. It is always set to Priority 3.

When a stack-related write is attempted to a region outside that set by the stack limit registers, a stack limit violation occurs. The interrupt request is cleared when it is handled. The stack limit violation interrupt vector is in the IIR at offset 0x1B0. It is always set to Priority 3.

## 5.3 Operation

### 5.3.1 Memory Management Unit (MMU)

Code execution takes place in the 64 KB logical memory space, which is divided into four segments: root, data, stack, and extended (XMEM). The root segment is always mapped starting at physical address 0x000000, but the other segments can be remapped to start at any physical 4 KB block boundary.

The data and stack segment mappings are set by writing to the appropriate register, as shown in Table 5-1. The DATASEG and STACKSEG registers provide backwards compatibility to the Rabbit 2000 and 3000 processors; these registers map directly to DATASEGL and STACKSEGL, but the contents of DATASEGH and STACKSEGH are set to zero.

**Table 5-1. Memory Management Registers**

Register	Segment	Size	Comments
DATASEG	Data	8 bits	Maps to DATASEGL; DATASEGH set to 0x00
DATASEGL	Data	8 bits	—
DATASEGH	Data	4 bits	—
STACKSEG	Stack	8 bits	Maps to STACKSEGL; STACKSEGH set to 0x00
STACKSEGL	Stack	8 bits	—
STACKSEGH	Stack	4 bits	—
XPC	XMEM	8 bits	Loaded via instructions <b>LD XPC, A</b> and <b>LD A, XPC</b>
LXPC	XMEM	12 bits	Loaded via instructions: <b>LD LXPC, HL</b> and <b>LD HL, LXPC</b>

Each of these registers provides a 4 KB offset that is added to the logical address to provide a physical address as shown in Figure 5-3.

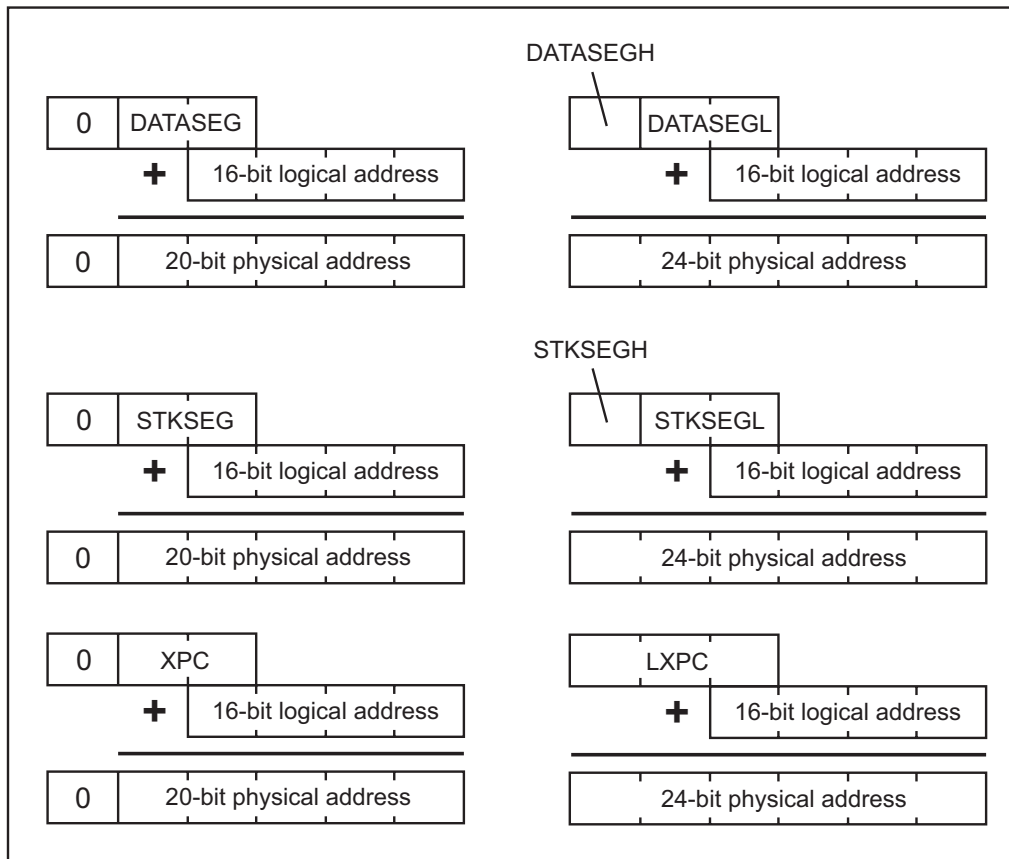

**Figure 5-3. MMU Operation**

### 5.3.2 Memory Bank Operation

On startup the Rabbit 5000 checks the status of the SYSCFG pins. To provide support for external memory, both SYSCFG pins should be set low and Memory Bank 0 enabled to use /CS0, /OE0, and /WE0 in 8-bit mode with four wait states and write protection enabled. It is expected that an external flash device containing startup code is attached to those strobes. The other memory banks come up undefined and their controls should be set via the appropriate MBxCR register to a valid setting before use.

If SYSCFG0 is high and SYSCFG1 is low, Memory Bank 0 is enabled to use /CS3, /OE0, and /WE0 in 16-bit mode. This allows the processor to start operation directly out of the internal SRAM.

The size of the memory banks is defined in the MECR register. The default size is 256 KB (the bank selection looks at the two most significant address bits), but this value can be adjusted down to 128 KB or up to 4 MB per bank.

The two address bits used to select the bank can be inverted in MBxCR, which enables mapping different sections of a memory device larger than the current memory bank into memory. Figure 5-4 shows an example of this feature.

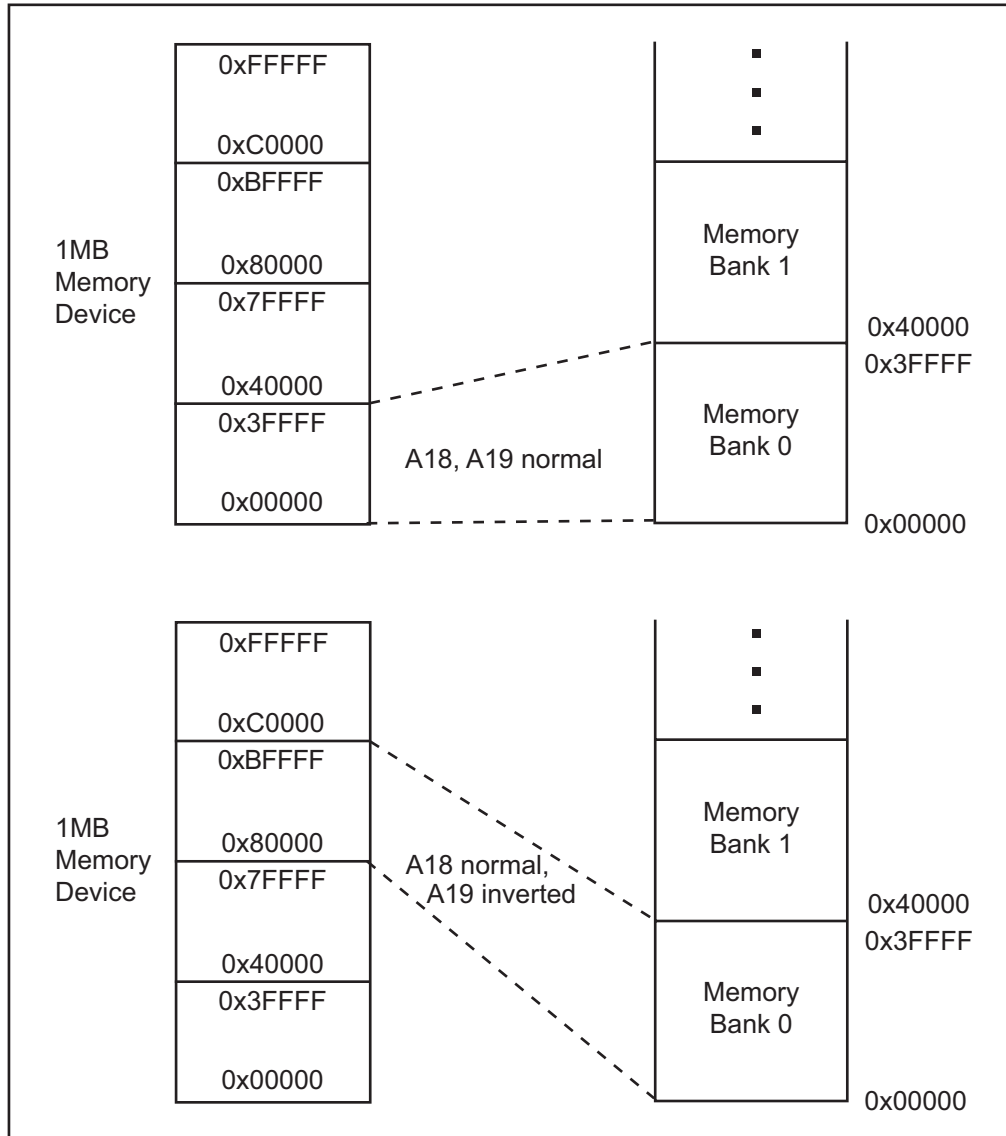

**Figure 5-4. Mapping Different Sections of a Memory Device Larger Than the Current Memory Bank**

It is possible to extend the timing of the /OE and/or /WE strobes by one half of a clock. This provides slightly longer strobes for slower memories; see the timing diagrams in Chapter 31. These options are available in MTCR.

It is possible to force /CS1 to be always active in MMIDR; enabling this will cause conflicts only if a device shares a /OE or /WE strobe with another device. This option allows faster access to particular memory devices.

### 5.3.3 Memory Modes

The Rabbit 5000 supports both 8-bit and 16-bit memories on all chip selects, including the internal SRAM. It also provides support for page-mode devices. The mode for each chip select is set in MACR; 8-bit mode is the default for all chip selects.

When in basic 8-bit mode, the wait states are selected in the memory bank registers, MBxCR; the options are 0, 1, 2, or 4 wait states. Note that this may put an upper bound on the processor clock speed, depending on the access time of your 8-bit memory device. When in 16-bit or page-mode (either 8- or 16-bit), the wait states are selected by the advanced chip select registers, ACSxCR.

When the 16-bit mode is enabled, Parallel Port H is used for the high byte of the data, and is configured automatically for this operation, overriding any other Parallel Port H function.

**Table 5-2. Memory Modes**

Mode	Byte Writes?	Word Reads?	Word Writes?	Wait State Register	Wait State Options
8-bit	Yes	No	No	MBxCR	0, 1, 2, 4
16-bit	Selectable	Yes	Yes	ACSxCR	0–7
8-bit Page Mode	Yes	No	No	ACSxCR	0–7 first access, 0–3 page accesses
16-bit Page Mode	Selectable	Yes	Yes	ACSxCR	0–7 first access, 0–3 page accesses

A 16-bit memory device may or may not support byte writes, so there is an option to select between these two cases in ACSxCR. With the default option any byte writes or unaligned word writes to a 16-bit memory will be suppressed (i.e., the /WE will not be asserted). Any aligned word reads or writes are recognized internally and are combined into just one write transaction on the external bus. The other option for the 16-bit bus does not inhibit byte writes or unaligned word writes, and replicates the byte data on both halves of the data bus in these cases. In this mode the A0 and /A0 signals must be used by the memory to enable the individual bytes.

**Table 5-3. A0 and /A0 Signals for Various Transaction Types**

Transaction Type	A0	/A0
Word Read (prefetch only)	Low	Low
Word Write	Low	Low
Byte Read or Write — Even Address	Low	High
Byte Read or Write — Odd Address	High	Low

All of the power-saving modes in Chapter 29 can be used with the 16-bit mode.



The second advanced bus mode is the Page Mode. This mode also can be enabled for any external chip select, and can be used with either 8-bit or 16-bit memories connected to these chip selects. Page-Mode memories provide for a faster access time if the requested data are in the same page as the previous data. In the Rabbit 5000 (and most memory devices) a page can be selected as either 8 or 16 bytes. Thus, if an address is identical to the previous address except in the lower four bits, the access time is assumed to be faster. These wait-state options are also controlled in the ACSxCR.

In Page Mode the chip select and /OE remain active from one page access to the next, and only the three or four least-significant bits of the address change to request the new data. This obviously interferes with a number of the power-saving modes and will take precedence over them for chip select accesses, as appropriate. The power-saving modes will still apply to the other chip select and output-enable signals. The logic recognizes which /OE is being used with each chip select in the Page Mode.

As mentioned previously, the ACSxCR registers each contain three fields to control the generation of wait states in the advanced bus modes. These settings are used in place of the wait-state setting in MBxCR when an advanced bus mode is enabled. When the 16-bit bus is enabled, from one to seven automatic wait states for memory read bus cycles can be enabled. This setting is also used for the first access when the Page Mode is enabled; a second setting selects the number of wait states for all subsequent reads in the Page Mode, allowing from zero to three automatic wait states for the same-page accesses in the Page Mode. The choices available for the advanced bus wait states are sufficient to allow interfacing to a variety of standard memories for any Rabbit 5000 speed grade.

When a 16-bit memory is connected to /CS0, the first few instructions must program the device to operate in 16-bit mode. This code is shown below. This code should be the first thing executed by your device. Because the processor is fetching bytes from a 16-bit memory device that is not connected to A0, only one-byte instructions can be used, and they must occur in pairs.

```

ORG      0000h
XOR      A          ; a <= 00000000
XOR      A
LD       H, A      ; h <= 00000000
LD       H, A
SCF
SCF
RLA          ; a <= 00000001
RLA          ; a <= 00000010
LD       B, A      ; b <= 00000010
LD       B, A
SCF
SCF
ADC      A, B      ; a <= 00000101
ADC      A, B      ; a <= 00000111
ADD      A, A      ; a <= 00001110
ADD      A, A      ; a <= 00011100
SCF
SCF

```

```

ADC      A, H      ; a <= 00011101
ADC      A, H
LD       L, A      ; l <= 00011101
LD       L, A
IOI
IOI
LD       (HL), B   ; MACR <= 00000010
LD       (HL), B   ; dummy memory write (no /WE)
NOP
NOP      ; required delay to start
NOP      ; up the 16-bit bus

```

### 5.3.4 Separate Instruction and Data Space

To make better use of the 64 KB of logical space, an option is provided to map code and data accesses in the same address space to separate devices. This is accomplished by enabling the inversion of A16 and the most-significant bit of the bank select bits for accesses in the root and data segments. Careful use of these features allows both code and data to separately use up to 64 KB of logical memory.

The RAM segment register (RAMSR) provides a shortcut for updating code by accessing it as data. It provides a “window” that uses the instruction address decoding when read or written as data. This mapping will only occur when the RAMSR is within the root or data segments; the RAMSR will be ignored if it is mapped to the stack segment or XPC window.

The *Rabbit 5000 Designer’s Handbook* provides further details on the use of the separate instruction and data space feature.

### 5.3.5 Memory Protection

Memory blocks may be protected at three separate granularities, as shown in Table 5-4. Writes can be prevented to any memory bank by writing to MBxCR. Writes can be prevented and trapped at a resolution of 64 KB by enabling protection for that block in the appropriate WPxR register. For further control, two of those 64 KB blocks can be further subdivided into 4 KB blocks by selecting them as the write protect segments A or B.

When a write is attempted to a block protected in WPxR, WPSxLR, or WPSxHR, a Priority 3 write-protect interrupt occurs. This feature is automatically enabled by writing to the block protection registers; to disable it, set all the write-protect block registers to zero.

**Table 5-4. Memory Protection Options**

Method	Block Size	Registers Used
Memory Bank	128 KB – 4 MB	MBxCR, MECR
Write-Protect Blocks	64 KB	WPCR, WPxR
Write Protect Segment A/B	4 KB	WPSxR, WPSxLR, WPSxHR

### 5.3.6 Stack Protection

The Rabbit 5000 provides stack overflow and underflow protection. Low and high logical address limits can be set in STKLLR and STKHLR; a Priority 3 stack-violation interrupt occurs when a stack-based write occurs within the 16 bytes below the upper limit or within the 16 bytes above the lower limit. Note that the writes will still occur even if they are within the 16 bytes surrounding the limits, but the interrupt can serve as a warning to the application that the stack is in danger of being over or underrun.

The stack checking can be enabled or disabled by writing to STKCR.

## 5.4 Register Descriptions

MMU Instruction/Data Register		(MMIDR)	(Address = 0x0010)
Bit(s)	Value	Description	
7	0	Internal I/O addresses are decoded using only the lower eight bits of the internal I/O address bus. This restricts internal I/O addresses to the range 0x0000–0x00FF.	
	1	Internal I/O addresses are decoded using all 15 bits of the address internal I/O address bus. This option must be selected to access internal I/O addresses of 0x0100 and higher.	
6		This bit is reserved and must be written with zero.	
5	0	Enable A16 and bank select address MSB inversion independent of instruction/data.	
	1	Enable A16 and bank select address MSB inversion for data accesses only. This enables the instruction/data split.	
4	0	Normal /CS1 operation.	
	1	Force /CS1 always active. This will not cause any conflicts as long as the memory using /CS1 does not also share an output enable or write enable with another memory.	
3	0	Normal operation.	
	1	For a data segment access, invert bank select address MSB before MBxCR decision.	
2	0	Normal operation.	
	1	For a data segment access, invert A16	
1	0	Normal operation.	
	1	For a root segment access, invert bank select address MSB before MBxCR decision.	
0	0	Normal operation.	
	1	For a root segment access, invert A16	

Stack Segment Register		(STACKSEG)	(Address = 0x0011)
Bit(s)	Value	Description	
7:0	Read	The current contents of this register are reported.	
	Write	Eight LSBs (MSBs are set to zero by write) of physical address offset to use if $SEGSIZ[7:4] \leq Addr[15:12] < 0xE$	

<b>Stack Segment Low Register (STACKSEGL) (Address = 0x001A)</b>		
<b>Bit(s)</b>	<b>Value</b>	<b>Description</b>
7:0	Read	The current contents of this register are reported.
	Write	Eight LSBs of physical address offset to use if $SEGSIZ[7:4] \leq Addr[15:12] < 0xE$

<b>Stack Segment High Register (STACKSEGH) (Address = 0x001B)</b>		
<b>Bit(s)</b>	<b>Value</b>	<b>Description</b>
7:4		These bits are reserved and should always be written as zero. These bits always return zeros when read.
3:0	Read	The current contents of this register are reported.
	Write	Four MSBs of physical address offset to use if $SEGSIZ[7:4] \leq Addr[15:12] < 0xE$

<b>Data Segment Register (DATSEG) (Address = 0x0012)</b>		
<b>Bit(s)</b>	<b>Value</b>	<b>Description</b>
7:0	Read	The current contents of this register are reported.
	Write	Eight LSBs (MSBs are set to zero by write) of physical address offset to use if: $SEGSIZ[3:0] \leq Addr[15:12] < SEGSIZ[7:4]$

<b>Data Segment Low Register (DATSEGL) (Address = 0x001E)</b>		
<b>Bit(s)</b>	<b>Value</b>	<b>Description</b>
7:0		Eight LSBs of physical address offset to use if $SEGSIZ[3:0] \leq Addr[15:12] < SEGSIZ[7:4]$

<b>Data Segment High Register (DATSEGH) (Address = 0x001F)</b>		
<b>Bit(s)</b>	<b>Value</b>	<b>Description</b>
7:4		These bits are reserved and should always be written as zero. These bits always return zeros when read.
3:0		Four MSBs of physical address offset to use if $SEGSIZ[3:0] \leq Addr[15:12] < SEGSIZ[7:4]$

<b>Segment Size Register (SEGSIZ) (Address = 0x0013)</b>		
<b>Bit(s)</b>	<b>Value</b>	<b>Description</b>
7:0	Read	The current contents of this register are reported.
7:4	Write	Boundary value for switching from DATSEG to STACKSEG for translation.
3:0	Write	Boundary value for switching from none to DATSEG for translation.

<b>Memory Bank x Control Register (MB0CR) (Address = 0x0014) (MB1CR) (Address = 0x0015) (MB2CR) (Address = 0x0016) (MB3CR) (Address = 0x0017)</b>		
<b>Bit(s)</b>	<b>Value</b>	<b>Description</b>
7:6	00	Four (five for writes) wait states for accesses in this bank.
	01	Two (three for writes) wait states for accesses in this bank.
	10	One (two for writes) wait states for accesses in this bank.
	11	Zero (one for writes) wait states for accesses in this bank.
5	0	Pass bank select address MSB for accesses in this bank.
	1	Invert bank select address MSB for accesses in this bank.
4	0	Pass bank select address LSB for accesses in this bank.
	1	Invert bank select address LSB for accesses in this bank.
3:2	00	/OE0 and /WE0 are active for accesses in this bank.
	01	/OE1 and /WE1 are active for accesses in this bank.
	10	/OE0 only is active for accesses in this bank (i.e., read-only). Transactions are normal in every other way.
	11	/OE1 only is active for accesses in this bank (i.e., read-only). Transactions are normal in every other way.
1:0	00	/CS0 is active for accesses in this bank.
	01	/CS1 is active for accesses in this bank.
	10	/CS2 is active for accesses in this bank.
	11	/CS3 (internal memory) is active for accesses in this bank. When standalone operation is selected (by strapping a pin), this bit combination is forced for MB0CR only.

<b>MMU Expanded Code Register (MECR)</b>		
<b>(Address = 0x0018)</b>		
<b>Bit(s)</b>	<b>Value</b>	<b>Description</b>
7:5	000	Bank select address is A[19:18].
	001	Bank select address is A[20:19].
	010	Bank select address is A[21:20].
	011	Bank select address is A[22:21].
	100	Bank select address is A[23:22].
	101	This bit combination is reserved and should not be used.
	110	This bit combination is reserved and should not be used.
	111	Bank select address is A[18:17].
4:3		These bits are reserved and should be written with zeros. Read returns zeros.
2:0	000	Normal operation.
	001	This bit combination is reserved and should not be used.
	010	This bit combination is reserved and should not be used.
	011	This bit combination is reserved and should not be used.
	100	For an XPC access, use MBOCR independent of bank select address.
	101	For an XPC access, use MB1CR independent of bank select address.
	110	For an XPC access, use MB2CR independent of bank select address.
	111	For an XPC access, use MB3CR independent of bank select address.

<b>Memory Timing Control Register (MTCR)</b>		
<b>(Address = 0x0019)</b>		
<b>Bit(s)</b>	<b>Value</b>	<b>Description</b>
7:4		These bits are reserved and should be written with zeros.
3	0	Normal timing for /OE1 (rising edge to rising edge, one clock minimum).
	1	Extended timing for /OE1 (one-half clock earlier than normal).
2	0	Normal timing for /OE0 (rising edge to rising edge, one clock minimum).
	1	Extended timing for /OE0 (one-half clock earlier than normal).
1	0	Normal timing for /WE1 (rising edge to falling edge, one and one-half clocks minimum).
	1	Extended timing for /WE1 (falling edge to falling edge, two clocks minimum).
0	0	Normal timing for /WE0 (rising edge to falling edge, one and one-half clocks minimum).
	1	Extended timing for /WE0 (falling edge to falling edge, two clocks minimum).

<b>Memory Alternate Control Register (MACR) (Address = 0x001D)</b>		
<b>Bit(s)</b>	<b>Value</b>	<b>Description</b>
7	0	Normal 8-bit operation for /CS3. Use MBxCR for wait states. This bit is used only when external memory is present.
	1	Normal 16-bit operation for /CS3. Use MBxCR for wait states. When stand-alone operation is selected (by strapping a pin), this bit is forced high.
6		This bit is reserved and must not be used.
5:4	00	Normal 8-bit operation for /CS2.
	01	Page-Mode 8-bit operation for /CS2.
	10	Normal 16-bit operation for /CS2.
	11	Page-Mode 16-bit operation for /CS2.
3:2	00	Normal 8-bit operation for /CS1.
	01	Page-Mode 8-bit operation for /CS1.
	10	Normal 16-bit operation for /CS1.
	11	Page-Mode 16-bit operation for /CS1.
1:0	00	Normal 8-bit operation for /CS0.
	01	Page-Mode 8-bit operation for /CS0.
	10	Normal 16-bit operation for /CS0.
	11	Page-Mode 16-bit operation for /CS0.



<b>Advanced Chip Select x Control Register</b>		
		<b>(ACS0CR) (Address = 0x0410)</b>
		<b>(ACS1CR) (Address = 0x0411)</b>
		<b>(ACS2CR) (Address = 0x0412)</b>
<b>Bit(s)</b>	<b>Value</b>	<b>Description</b>
7:5	000	Zero extra wait states for reads, writes, or first Page-Mode access.
	001	One extra wait state for reads, writes, or first Page-Mode read access.
	010	Two extra wait states for reads, writes, or first Page-Mode access.
	011	Three extra wait states for reads, writes, or first Page-Mode read access.
	100	Four extra wait states for reads, writes, or first Page-Mode read access.
	101	Five extra wait states for reads, writes, or first Page-Mode read access.
	110	Six extra wait state for reads, writes, or first Page-Mode read access.
	111	Seven extra wait state for reads, writes, or first Page-Mode read access.
4:3	00	Zero extra wait states for subsequent Page-Mode accesses.
	01	One extra wait state for subsequent Page-Mode accesses.
	10	Two extra wait states for subsequent Page-Mode accesses.
	11	Three extra wait states for subsequent Page-Mode accesses.
2		This bit is reserved and should not be used.
1	0	Page size 16 bytes.
	1	Page size 8 bytes.
0	0	Disable byte writes on 16-bit bus.
	1	Enable byte writes on 16-bit bus.

<b>RAM Segment Register</b>		
		<b>(RAMSR) (Address = 0x0448)</b>
<b>Bit(s)</b>	<b>Value</b>	<b>Description</b>
7:2		Compare value for RAM segment limit checking.
1:0	00	Disable RAM segment limit checking.
	01	Select data-type MMU translation if PC[15:10] is equal to RAMSR[7:2].
	10	Select data-type MMU translation if PC[15:11] is equal to RAMSR[7:3].
	11	Select data-type MMU translation if PC[15:12] is equal to RAMSR[7:4].

<b>Write Protection Control Register (WPCR) (Address = 0x0440)</b>		
<b>Bit(s)</b>	<b>Value</b>	<b>Description</b>
7:1		These bits are reserved and should be written with zeros.
0	0	Write protection in User Mode only.
	1	Write protection in System and User modes.

Write-Protect x Register		
	(WP0R)	(Address = 0x0460)
	(WP1R)	(Address = 0x0461)
	(WP2R)	(Address = 0x0462)
	(WP3R)	(Address = 0x0463)
	(WP4R)	(Address = 0x0464)
	(WP5R)	(Address = 0x0465)
	(WP6R)	(Address = 0x0466)
	(WP7R)	(Address = 0x0467)
	(WP8R)	(Address = 0x0468)
	(WP9R)	(Address = 0x0469)
	(WP10R)	(Address = 0x046A)
	(WP11R)	(Address = 0x046B)
	(WP12R)	(Address = 0x046C)
	(WP13R)	(Address = 0x046D)
	(WP14R)	(Address = 0x046E)
	(WP15R)	(Address = 0x046F)
	(WP16R)	(Address = 0x0470)
	(WP17R)	(Address = 0x0471)
	(WP18R)	(Address = 0x0472)
	(WP19R)	(Address = 0x0473)
	(WP20R)	(Address = 0x0474)
	(WP21R)	(Address = 0x0475)
	(WP22R)	(Address = 0x0476)
	(WP23R)	(Address = 0x0477)
	(WP24R)	(Address = 0x0478)
	(WP25R)	(Address = 0x0479)
	(WP26R)	(Address = 0x047A)
	(WP27R)	(Address = 0x047B)
	(WP28R)	(Address = 0x047C)
	(WP29R)	(Address = 0x047D)
	(WP30R)	(Address = 0x047E)
	(WP31R)	(Address = 0x047F)
Bit(s)	Value	Description
7:0	0	Disable write protection for the corresponding 64 KB segment.
	1	Enable write protection for the corresponding 64 KB segment. The eight-bit address of the segment to be write-protected is formed using bits [4:0] of the WPxR register address concatenated with the bit address of the corresponding bit in the register.

<b>Write-Protect Segment x Register</b>		
		<b>(WPSAR)</b> <b>(WPSBR)</b>
		<b>(Address = 0x0480)</b> <b>(Address = 0x0484)</b>
<b>Bit(s)</b>	<b>Value</b>	<b>Description</b>
7:0		When these eight bits [23:16] match bits of the physical address, write-protect that 64 KB range in 4 KB increments using WPSxLR and WPSxHR.

<b>Write-Protect Segment x Low Register</b>		
		<b>(WPSALR)</b> <b>(WPSBLR)</b>
		<b>(Address = 0x0481)</b> <b>(Address = 0x0485)</b>
<b>Bit(s)</b>	<b>Value</b>	<b>Description</b>
7	0	Disable 4 KB write protect for relative address 0x7000–0x7FFF in WP Segment x.
	1	Enable 4 KB write protect for relative address 0x7000–0x7FFF in WP Segment x.
6	0	Disable 4 KB write protect for relative address 0x6000–0x6FFF in WP Segment x.
	1	Enable 4 KB write protect for relative address 0x6000–0x6FFF in WP Segment x.
5	0	Disable 4 KB write protect for relative address 0x5000–0x5FFF in WP Segment x.
	1	Enable 4 KB write protect for relative address 0x5000–0x5FFF in WP Segment x.
4	0	Disable 4 KB write protect for relative address 0x4000–0x4FFF in WP Segment x.
	1	Enable 4 KB write protect for relative address 0x4000–0x4FFF in WP Segment x.
3	0	Disable 4 KB write protect for relative address 0x3000–0x3FFF in WP Segment x.
	1	Enable 4 KB write protect for relative address 0x3000–0x3FFF in WP Segment x.
2	0	Disable 4 KB write protect for relative address 0x2000–0x2FFF in WP Segment x.
	1	Enable 4 KB write protect for relative address 0x2000–0x2FFF in WP Segment x.
1	0	Disable 4 KB write protect for relative address 0x1000–0x1FFF in WP Segment x.
	1	Enable 4 KB write protect for relative address 0x1000–0x1FFF in WP Segment x.
0	0	Disable 4 KB write protect for relative address 0x0000–0x0FFF in WP Segment x.
	1	Enable 4 KB write protect for relative address 0x0000–0x0FFF in WP Segment x.

<b>Write-Protect Segment x High Register (WPSAHR) (WPSBHR) (Address = 0x0482) (Address = 0x0486)</b>		
<b>Bit(s)</b>	<b>Value</b>	<b>Description</b>
7	0	Disable 4 KB write protect for relative address 0xF000–0xFFFF in WP Segment x.
	1	Enable 4 KB write protect for relative address 0xF000–0xFFFF in WP Segment x.
6	0	Disable 4 KB write protect for relative address 0xE000–0xEFFF in WP Segment x.
	1	Enable 4 KB write protect for relative address 0xE000–0xEFFF in WP Segment x.
5	0	Disable 4 KB write protect for relative address 0xD000–0xDFFF in WP Segment x.
	1	Enable 4 KB write protect for relative address 0xD000–0xDFFF in WP Segment x.
4	0	Disable 4 KB write protect for relative address 0xC000–0xCFFF in WP Segment x.
	1	Enable 4 KB write protect for relative address 0xC000–0xCFFF in WP Segment x.
3	0	Disable 4 KB write protect for relative address 0xB000–0xBFFF in WP Segment x.
	1	Enable 4 KB write protect for relative address 0xB000–0xBFFF in WP Segment x.
2	0	Disable 4 KB write protect for relative address 0xA000–0xAFFF in WP Segment x.
	1	Enable 4 KB write protect for relative address 0xA000–0xAFFF in WP Segment x.
1	0	Disable 4 KB write protect for relative address 0x9000–0x9FFF in WP Segment x.
	1	Enable 4 KB write protect for relative address 0x9000–0x9FFF in WP Segment x.
0	0	Disable 4 KB write protect for relative address 0x8000–0x8FFF in WP Segment x.
	1	Enable 4 KB write protect for relative address 0x8000–0x8FFF in WP Segment x.

<b>Stack Limit Control Register (STKCR) (Address = 0x0444)</b>		
<b>Bit(s)</b>	<b>Value</b>	<b>Description</b>
7:1		These bits are reserved and should be written with zeros.
0	0	Disable stack-limit checking.
	1	Enable stack-limit checking.

<b>Stack Low Limit Register (STKLLR) (Address = 0x0445)</b>		
<b>Bit(s)</b>	<b>Value</b>	<b>Description</b>
7:0		Lower limit for stack-limit checking. If a stack operation or stack-relative memory access is attempted at an address less than {STKLLR, 0x10}, a stack-limit violation interrupt is generated.

<b>Stack High Limit Register (STKHLR) (Address = 0x0446)</b>		
<b>Bit(s)</b>	<b>Value</b>	<b>Description</b>
7:0		Upper limit for stack-limit checking. If a stack operation or stack-relative memory access is attempted at an address greater than {STKHLR, 0xEF}, a stack-limit violation interrupt is generated.

## 6. INTERRUPTS

### 6.1 Overview

The Rabbit 5000 can operate at one of four priority levels, 0–3, with Priority 0 being the expected standard operating level. The current priority and up to three previous priority levels are kept in the processor’s 8-bit IP register, where bits 0–1 contain the current priority. Every time an interrupt is handled or an IPSET instruction occurs, the value in the register is shifted left by two bits, and the new priority placed in bits 0–1. When an IPRES or IRET instruction occurs, the value in IP is shifted right by two bits (bits 0–1 are shifted into bits 6–7). On reset, the processor starts at Priority 3.

Most interrupts can be set to be Priority 1–3. A pending interrupt will be handled only if its interrupt priority is greater than the current processor priority. This means that even a Priority 3 interrupt can be blocked if the processor is currently at Priority 3. The System Mode Violation, Stack Limit Violation, Write Protection Violation, secondary watchdog, and breakpoint interrupts are always enabled at Priority 3. In addition, when the System/User Mode is enabled and the processor is in the User Mode, the processor will not actually enter Priority 3; any attempt to enter Priority 3 will actually be requested as Priority 2.

When an interrupt is handled, a call is executed to a fixed location in the interrupt vector tables. This operation requires 11 clocks, the minimum interrupt latency for the Rabbit 5000. There are two vector tables, the internal and the external interrupt vector tables, that can be located anywhere in logical memory by setting the processor’s IIR and EIR registers. The IIR and EIR registers hold the upper byte of each table’s address. For example, if IIR is loaded with 0xC4, then the internal interrupt vector table will start at the logical memory address 0xC400.

The internal interrupt vector table occupies 512 bytes, and the external interrupt vector table is 256 bytes in size. Since the RST and SYSCALL vectors use all eight bits of the IIR for addressing, the lowermost bit of IIR should always be set to zero so to keep some vectors from inadvertently overlapping.

Each interrupt’s vector begins on a 16-byte boundary inside the vector tables. It may be possible to fit a small routine into that space, but it is typical to place a call to a separate routine in that location.

Some Rabbit 5000 instructions are “chained atomic,” which means that an interrupt cannot occur between that instruction and the following instruction. These instructions are useful for doing things like exiting interrupt handlers properly or updating semaphores.

## 6.2 Operation

To ensure proper operation, all interrupt handler routines should be written according to the following guidelines.

- Push all registers to be used by the routine onto the stack before use, and pop them off the stack before returning from the ISR.
- Keep the ISR as short and fast as possible. The use of assembly code is strongly recommended.
- If the ISR will run for some time, lower the interrupt priority as soon as possible within the ISR to allow other interrupts to occur.
- A number of special rules apply to interrupts when operating in the system/user mode; please see the appropriate chapter for more details.

## 6.3 Interrupt Tables

Table 6-1 shows the structure of the internal interrupt vector table. The first column is the vector address offset within the table. The second column shows the vectors in the first 256 bytes of the table, and the third column shows the vectors in the second 256 bytes.

**Table 6-1. Internal Interrupt Vector Table Structure**

Offset	0x0000+	0x0100+
0x00	Periodic Interrupt	—
0x10	Secondary Watchdog	—
0x20	RST 10	—
0x30	RST 18	—
0x40	RST20	—
0x50	RST 28	—
0x60	Syscall instruction	—
0x70	RST 38	PWM
0x80	Slave Port	Sys/User Mode Violation
0x90	Write Protect Violation	Quadrature Decoder
0xA0	Timer A	Input Capture
0xB0	Timer B	Stack Limit Violation
0xC0	Serial Port A	Serial Port E
0xD0	Serial Port B	Serial Port F
0xE0	Serial Port C	Network Port B/C
0xF0	Serial Port D	Timer C



Table 6-2 shows the structure of the external interrupt vector table. Each interrupt vector falls on a 16-byte boundary inside the table.

**Table 6-2. External Interrupt Vector Table Structure**

Offset	0x0000+
0x00	External Interrupt 0
0x10	External Interrupt 1
0x20	—
0x30	—
0x40	Breakpoints
0x50	—
0x60	—
0x70	—
0x80	DMA Channel 0
0x90	DMA Channel 1
0xA0	DMA Channel 2
0xB0	DMA Channel 3
0xC0	DMA Channel 4
0xD0	DMA Channel 5
0xE0	DMA Channel 6
0xF0	DMA Channel 7

There is a priority among interrupts if multiple requests are pending, as shown in Table 6-3. Interrupts marked as “cleared automatically” have their requests cleared when the interrupt is first handled.

**Table 6-3. Interrupt Priorities**

Priority	Interrupt Source	Action Required to Clear the Interrupt
Highest	Breakpoint	Read the status from BDCR.
	System Mode Violation	Cleared automatically.
	Stack Limit Violation	Cleared automatically.
	Write Protection Violation	Cleared automatically.
	Secondary Watchdog	Restart secondary watchdog by writing to WDTCR.
	External Interrupt 1	Cleared automatically.
	External Interrupt 0	Cleared automatically.
	Periodic Interrupt	Read the status from GCSR.
	Quadrature Decoder	Read the status from QDCSR.
	Timer B	Read the status from TBCSR.
	Timer A	Read the status from TACSR.
	Input Capture	Read the status from ICCSR.
	PWM	Write any PWM register.
	Timer C	Read the status from TCCSR.
	Slave Port	Rd: Read from SPD0R, SPD1R or SPD2R. Wr: Write to SPD0R, SPD1R, SPD2R or dummy write to SPSR.
	DMA 7	Cleared automatically.
	DMA 6	Cleared automatically.
	DMA 5	Cleared automatically.
	DMA 4	Cleared automatically.
	DMA 3	Cleared automatically.
	DMA 2	Cleared automatically.
	DMA 1	Cleared automatically.
	DMA 0	Cleared automatically.
	Network Port B/C	Read interrupt status from NBCSR or NCCSR.
	Serial Port E	Rx: Read from SEDR or SEAR. Tx: Write to SEDR, SEAR, SELR or dummy write to SESR.
	Serial Port F	Rx: Read from SFDR or SFAR. Tx: Write to SFDR, SFAR, SFLR or dummy write to SFSR.
	Serial Port A	Rx: Read from SADR or SAAR. Tx: Write to SADR, SAAR, SALR or dummy write to SASR.
Serial Port B	Rx: Read from SBDR or SBAR. Tx: Write to SBDR, SBAR, SBLR or dummy write to SBSR.	
Serial Port C	Rx: Read from SCDR or SCAR. Tx: Write to SCDR, SCAR, SCLR or dummy write to SCSR.	
Lowest	Serial Port D	Rx: Read from SDDR or SDAR. Tx: Write to SDDR, SDAR, SDLR or dummy write to SDSR.

# 7. EXTERNAL INTERRUPTS

## 7.1 Overview

The Rabbit 5000 has six external interrupts available, and they share two interrupt vectors. In the case of multiple interrupts sharing an interrupt vector, the data register corresponding to the parallel port(s) being used can be read. Each interrupt vector can be set to trigger on a rising edge, a falling edge, or either edge.

The signal on the external interrupt pin must be present for at least three peripheral clock cycles to be detected. In addition, the Rabbit 5000 has a minimum latency of 11 clocks to respond to an interrupt, so the minimum external interrupt response time is three peripheral clock cycles plus 11 processor clock cycles.

## 7.2 Block Diagram

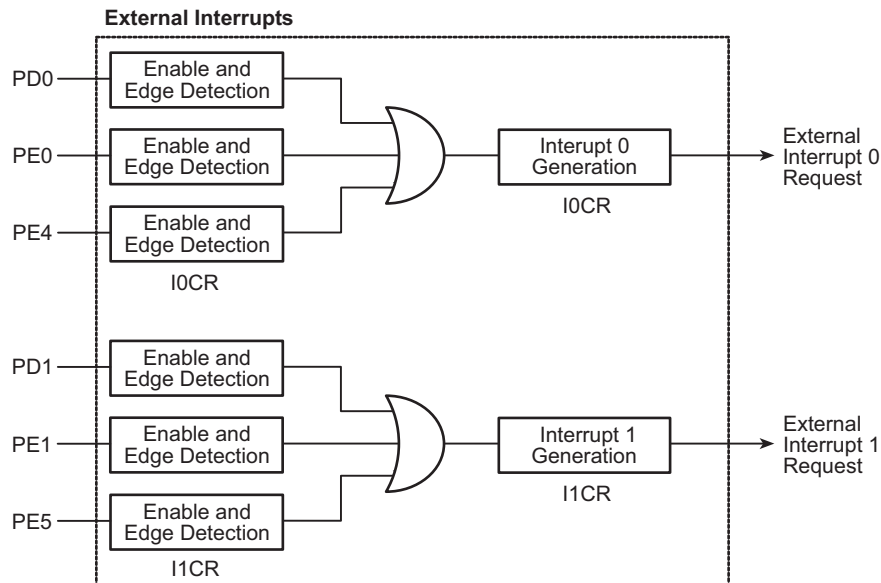

## 7.2.1 Registers

Register Name	Mnemonic	I/O Address	R/W	Reset
Interrupt 0 Control Register	IOCR	0x0098	R/W	xx000000
Interrupt 1 Control Register	IICR	0x0099	R/W	xx000000

## 7.3 Dependencies

### 7.3.1 I/O Pins

The external interrupts can be enabled on pins PD0, PD1, PE0, PE1, PE4, and PE5. Each pin is associated with a particular interrupt vector as shown in Table 7-1 below.

**Table 7-1. Rabbit 5000 Interrupt Vectors**

Vector	Register	Pins
Interrupt 0	IOCR	PD0, PE0, PE4
Interrupt 1	IICR	PD1, PE1, PE5

### 7.3.2 Clocks

The external interrupts are controlled by the peripheral clock. A pulse must be present for at least three peripheral clock cycles to trigger an interrupt.

### 7.3.3 Interrupts

An external interrupt is generated whenever the selected edge occurs on an enabled pin. The interrupt request is automatically cleared when the interrupt is handled.

The external interrupt vectors are in the EIR at offsets 0x000 and 0x010. They can be set as Priority 1, 2, or 3 in the appropriate IxCR.

## 7.4 Operation

The following steps must be taken to enable the external interrupts.

1. Write the vector(s) to the interrupt service routine to the external interrupt table.
2. Configure IxCR to select which pins are enabled for external interrupts, what edges are detected on each pin, and the interrupt priority.

### 7.4.1 Example ISR

A sample interrupt handler is shown below.

```
extInt_isr::  
    ; respond to external interrupt here  
    ; interrupt is automatically cleared by interrupt acknowledge  
    ipres  
    ret
```

## 7.5 Register Descriptions

Interrupt x Control Register			(I0CR)	(Address = 0x0098)
			(I1CR)	(Address = 0x0099)
Bit(s)	Value	Description		
7:6	00	Parallel Port D low nibble interrupt disabled.		
	01	Parallel Port D low nibble interrupt on falling edge.		
	10	Parallel Port D low nibble interrupt on rising edge.		
	11	Parallel Port D low nibble interrupt on both edges.		
5:4	00	Parallel Port E high nibble interrupt disabled.		
	01	Parallel Port E high nibble interrupt on falling edge.		
	10	Parallel Port E high nibble interrupt on rising edge.		
	11	Parallel Port E high nibble interrupt on both edges.		
3:2	00	Parallel Port E low nibble interrupt disabled.		
	01	Parallel Port E low nibble interrupt on falling edge.		
	10	Parallel Port E low nibble interrupt on rising edge.		
	11	Parallel Port E low nibble interrupt on both edges.		
1:0	00	This external interrupt is disabled.		
	01	This external interrupt uses Interrupt Priority 1.		
	10	This external interrupt uses Interrupt Priority 2.		
	11	This external interrupt uses Interrupt Priority 3.		



# 8. PARALLEL PORT A

## 8.1 Overview

Parallel Port A is a byte-wide port that can be used as an input or an output port. Parallel Port A is also used as the data bus for the slave port and external I/O bus. The Slave Port Control Register (SPCR) is used to configure how Parallel Port A is used. Parallel Port A is an input at startup or reset. If the SMODE pins have selected the slave port bootstrap mode, Parallel Port A will be the slave port data bus until disabled by the processor. Parallel Port A can also be used as an external I/O data bus to isolate external I/O from the main data bus.

**Table 8-1. Parallel Port A Pin Alternate Output Functions**

Pin Name	Slave Port Data Bus	External I/O Bus
PA[7:0]	SD[7:0]	ID[7:0]

### 8.1.1 Block Diagram

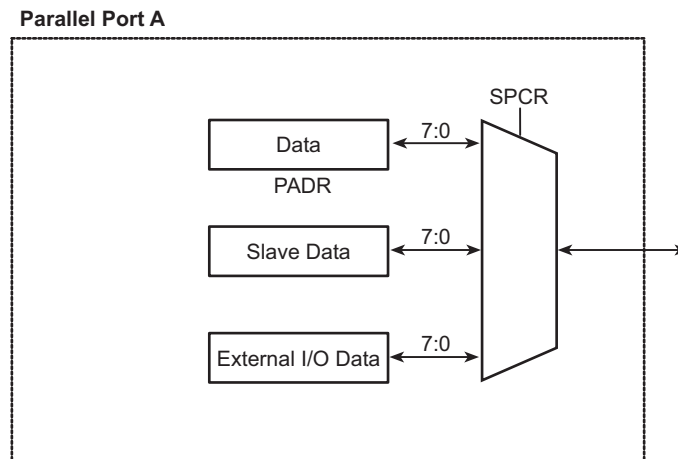

### 8.1.2 Registers

Register Name	Mnemonic	I/O Address	R/W	Reset
Port A Data Register	PADR	0x0030	R/W	xxxxxxxx

## 8.2 Dependencies

### 8.2.1 I/O Pins

Parallel Port A uses pins PA0 through PA7. These pins can be used as follows.

- General-purpose 8-bit data input (write 0x080 to SPCR)
- General-purpose 8-bit data output (write 0x084 to SPCR)
- Slave port data bus (write 0x088 to SPCR)
- External I/O data bus (write 0x08C to SPCR)

All Parallel Port A bits are inputs at startup or reset.

See the associated peripheral chapters for details on how they use Parallel Port A.

### 8.2.2 Clocks

Any outputs on Parallel Port A are clocked by the peripheral clock.

### 8.2.3 Other Registers

Register	Function
SPCR	Used to set up Parallel Port A.

### 8.2.4 Interrupts

There are no interrupts associated with Parallel Port A, except when the slave port is being used.

## 8.3 Operation

The following steps explain how to set up Parallel Port A.

1. Select the desired mode using SPCR.
2. If the slave port or external I/O bus is selected, refer to the chapters for those peripherals for further setup.

Once Parallel Port A is set up, data can be read or written by accessing PADR. Note that Parallel Port A is not available for general-purpose I/O while the slave port or the external I/O bus is selected. Selecting these options for Parallel Port A affects Parallel Port B because Parallel Port B is then used for address and control signals.



## 8.4 Register Descriptions

Parallel Port A Data Register		(PADR)	(Address = 0x0030)
Bit(s)	Value	Description	
7:0	Read	The current state of Parallel Port A pins PA7–PA0 is reported.	
	Write	The Parallel Port A buffer is written with this value for transfer to the Parallel Port A output register on the next rising edge of the peripheral clock.	

Slave Port Control Register		(SPCR)	(Address = 0x0024)
Bit(s)	Value	Description	
7	0	Program fetch as a function of the SMODE pins.	
	1	Ignore the SMODE pins program fetch function.	
6:5	read	These bits report the state of the SMODE pins.	
	write	These bits are ignored and should be written with zero.	
4:2	000	Disable the slave port. Parallel Port A is a byte-wide input port.	
	001	Disable the slave port. Parallel Port A is a byte-wide output port.	
	010	Enable the slave port, with /SCS from Parallel Port E bit 7.	
	011	Enable the external I/O bus. Parallel Port A is used for the data bus and Parallel Port B[7:2] is used for the address bus.	
	100	This bit combination is reserved and should not be used.	
	101	This bit combination is reserved and should not be used.	
	110	Enable the slave port, with /SCS from Parallel Port B bit 6.	
	111	Enable the external I/O bus. Parallel Port A is used for the data bus and Parallel Port B[7:0] is used for the address bus.	
1:0	00	Slave port interrupts are disabled.	
	01	Slave port interrupts use Interrupt Priority 1.	
	10	Slave port interrupts use Interrupt Priority 2.	
	11	Slave port interrupts use Interrupt Priority 3.	



# 9. PARALLEL PORT B

## 9.1 Overview

Parallel Port B is a byte-wide port with each bit programmable for direction. The Parallel Port B pins are also used to access other peripherals on the chip—the slave port, the auxiliary I/O address bus, and clock I/O for clocked serial mode option for Serial Ports A and B. The Slave Port Control Register (SPCR) is used to configure how Parallel Port B is used when selecting the slave port or the external I/O bus modes.

When the slave port is enabled, either under program control or during parallel bootstrap, Parallel Port B pins carry the Slave Attention output signal, and the Slave Read strobe, Slave Write strobe, and Slave Address inputs. The Slave Chip Select can also be programmed to come from a Parallel Port B pin.

When the external I/O bus option is enabled, either six or eight pins carry the external I/O address signals selected in SPCR.

Two pins are used for the clocks for Serial Ports A and B when they are configured for the clocked serial mode. These two inputs can be used as clock outputs for these ports if selected in the respective serial port control registers. Note that the clocked serial output clock selection overrides all other programming for the two relevant Parallel Port B pins.

**Table 9-1. Parallel Port B Pin Alternate Output Functions**

Pin Name	Slave Port	Serial Ports A–D	External I/O Bus
PB7	/SLVATTN	—	IA5
PB6	/SCS	—	IA4
PB5	SA1	—	IA3
PB4	SA0	—	IA2
PB3	/SRD	—	IA1
PB2	/SWR	—	IA0
PB1	—	SCLKA	IA7
PB0	—	SCLKB	IA6

## 9.1.1 Block Diagram

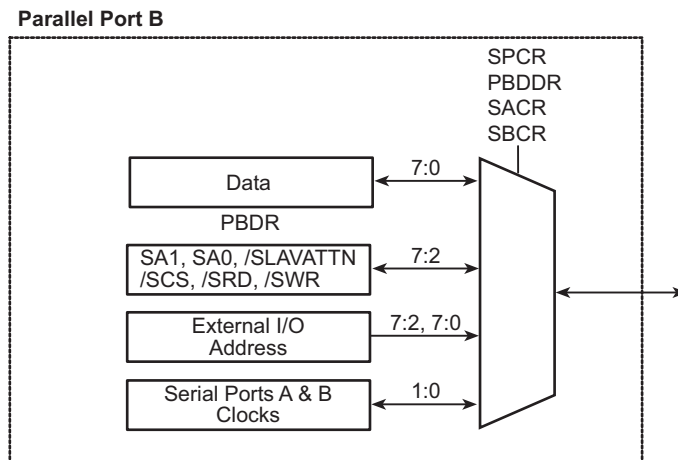

## 9.1.2 Registers

Register Name	Mnemonic	I/O Address	R/W	Reset
Port B Data Register	PBDR	0x0040	R/W	00xxxxxx
Port B Data Direction Register	PBDDR	0x0047	R/W	11000000

## 9.2 Dependencies

### 9.2.1 I/O Pins

Parallel Port B uses pins PB0 through PB7. These pins can be used individually as data inputs or outputs; as the address bits for the external I/O bus; as control signals for the slave port; or as clocks for Serial Ports A and B.

On startup, bits 6 and 7 are outputs set low for backwards compatibility with the Rabbit 2000. All other pins are inputs.

Note that when the external I/O bus or slave port is enabled in SPCR, the Parallel Port B pins associated with those peripherals perform those actions, no matter what the settings are in PBDR or PBDDR. See the associated peripheral chapters for details on how they use Parallel Port B.

### 9.2.2 Clocks

All outputs on Parallel Port B are clocked by the peripheral clock (perclk).

### 9.2.3 Other Registers

Register	Function
SPCR	Sets the Parallel Port B function for some pins if the slave port or external I/O bus is enabled.

## 9.2.4 Interrupts

There are no interrupts associated with Parallel Port B, except when the slave port is being used.

## 9.3 Operation

The following steps must be taken before using Parallel Port B.

1. Select the desired input/output direction for each pin via PBDDR. Note that this setting is superseded for some pins if the slave port or external I/O bus is enabled in SPCR or if the clocked serial mode is enabled for Serial Ports A or B.
2. If the slave port or the external I/O bus is selected, refer to the chapters for those peripherals for further setup information.

Once the port is set up, data can be read or written by accessing PBDR. The value in PBDR of an output pin will reflect its current output value, but any value written to an input pin will not appear on that pin until that pin becomes an output.

## 9.4 Register Descriptions

Parallel Port B Data Register		(PBDR)	(Address = 0x0040)
Bit(s)	Value	Description	
7:0	Read	The current state of Parallel Port B pins PB7–PB0 is reported.	
	Write	The Parallel Port B buffer is written with this value for transfer to the Parallel Port B output register on the next rising edge of the peripheral clock.	

Parallel Port B Data Direction Register		(PBDDR)	(Address = 0x0047)
Bit(s)	Value	Description	
7:0	0	The corresponding port bit is an input.	
	1	The corresponding port bit is an output.	

<b>Slave Port Control Register (SPCR) (Address = 0x0024)</b>		
<b>Bit(s)</b>	<b>Value</b>	<b>Description</b>
7	0	Program fetch as a function of the SMODE pins.
	1	Ignore the SMODE pins program fetch function.
6:5	Read	These bits report the state of the SMODE pins.
	Write	These bits are ignored and should be written with zero.
4:2	000	Disable the slave port. Parallel Port A is a byte-wide input port.
	001	Disable the slave port. Parallel Port A is a byte-wide output port.
	010	Enable the slave port, with /SCS from Parallel Port E bit 7.
	011	Enable the external I/O bus. Parallel Port A is used for the data bus and Parallel Port B[7:2] is used for the address bus.
	100	This bit combination is reserved and should not be used.
	101	This bit combination is reserved and should not be used.
	110	Enable the slave port, with /SCS from Parallel Port B bit 6.
	111	Enable the external I/O bus. Parallel Port A is used for the data bus and Parallel Port B[7:0] is used for the address bus.
1:0	00	Slave port interrupts are disabled.
	01	Slave port interrupts use Interrupt Priority 1.
	10	Slave port interrupts use Interrupt Priority 2.
	11	Slave port interrupts use Interrupt Priority 3.

# 10. PARALLEL PORT C

## 10.1 Overview

Parallel Port C is a byte-wide port with each bit programmable for data direction and drive level. These are simple inputs and outputs controlled and reported in the Port C Data Register (PCDR).

All the Parallel Port C pins have alternate output functions, and most of them can be used as inputs to various on-chip peripherals.

**Table 10-1. Parallel Port C Pin Alternate Output Functions**

Pin Name	Alt Out 0	Alt Out 1	Alt Out 2	Alt Out 3
PC7	TXA	I7	PWM3	SCLKC
PC6	TXA	I6	PWM2	TXE
PC5	TXB	I5	PWM1	RCLKE
PC4	TXB	I4	PWM0	TCLKE
PC3	TXC	I3	TIMER C3	SCLKD
PC2	TXC	I2	TIMER C2	TXF
PC1	TXD	I1	TIMER C1	RCLKF
PC0	TXD	I0	TIMER C0	TCLKF

**Table 10-2. Parallel Port C Pin Alternate Input Functions**

Pin Name	Input Capture	Serial Ports A–D	Serial Ports E–F
PC7	×	RXA	RXE
PC6	—	—	—
PC5	×	RXB	RCLKE
PC4	—	—	TCLKE
PC3	×	RXC	RXF
PC2	—	—	—
PC1	×	RXD	RCLKF
PC0	—	—	TCLKF

After reset, the default condition for Parallel Port C is four outputs (the even-numbered bits) and four inputs (the odd-numbered bits). For compatibility with the Rabbit 2000 and the Rabbit 3000 microprocessors, these outputs are driven with a logic zero (low) on PC6 and a logic one (high) on PC4, PC2, and PC0. When PCDR is read, the value of the voltage on the pin is returned. If the pin is an output, the value it is set to is returned.

### 10.1.1 Block Diagram

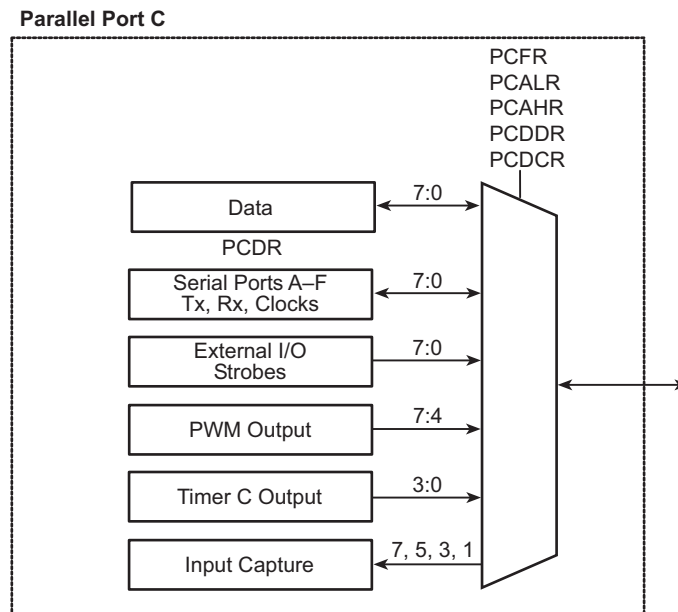

### 10.1.2 Registers

Register Name	Mnemonic	I/O Address	R/W	Reset
Port C Data Register	PCDR	0x0050	R/W	00010101
Port C Data Direction Register	PCDDR	0x0051	R/W	01010101
Port C Alternate Low Register	PCALR	0x0052	R/W	00000000
Port C Alternate High Register	PCADR	0x0053	R/W	00000000
Port C Drive Control Register	PCDCR	0x0054	R/W	00000000
Port C Function Register	PCFR	0x0055	R/W	00000000



## 10.2 Dependencies

### 10.2.1 I/O Pins

Parallel Port C uses pins PC0 through PC7. These pins can be used individually as data inputs or outputs; as serial port transmit and receive for Serial ports A–F; as clocks for Serial Ports C–F; as external I/O strobes; or as outputs for the PWM and Timer C peripherals. The input capture peripheral can also watch pins PC7, PC5, PC3, and PC1.

On startup, PC4, PC2, and PC0 are outputs set high, PC6 is set low, and the other pins are inputs for compatibility with the Rabbit 3000.

The individual pins can be set to be open-drain via PCDCR.

See the associated peripheral chapters for details on how they use Parallel Port C.

### 10.2.2 Clocks

All outputs on Parallel Port C are clocked by the peripheral clock.

### 10.2.3 Other Registers

Register	Function
SACR, SBCR, SCCR, SDCR, SECR, SFCR	Select a Parallel Port C pin as serial data (and optional clock) input.
ICS1R, ICS2R	Select a Parallel Port C pin as a start/stop condition for Input Capture input.

### 10.2.4 Interrupts

There are no interrupts associated with Parallel Port C.

## 10.3 Operation

The following steps must be taken before using Parallel Port C.

1. Select the desired input/output direction for each pin via PCDDR.
2. Select driven or open-drain functionality for outputs via PCDCR.
3. If an alternate peripheral output function is desired for a pin, select it via PCALR or PCAHR and then enable it via PCFR. Refer to the appropriate peripheral chapter for further use of that pin.

Once the port is set up, data can be read or written by accessing PCDR. The value in PCDR of an output pin will reflect its current output value, but any value written to an input pin will not appear on that pin until that pin becomes an output.

## 10.4 Register Descriptions

Parallel Port C Data Register (PCDR) (Address = 0x0050)		
Bit(s)	Value	Description
7:0	Read	The current state of Parallel Port C pins PC7–PC0 is reported.
	Write	The Parallel Port C buffer is written with this value for transfer to the Parallel Port C output register on the next rising edge of the peripheral clock.

Parallel Port C Data Direction Register (PCDDR) (Address = 0x0051)		
Bit(s)	Value	Description
7:0	0	The corresponding port bit is an input.
	1	The corresponding port bit is an output.

Parallel Port C Alternate Low Register (PCALR) (Address = 0x0052)		
Bit(s)	Value	Description
7:6	00	Parallel Port C bit 3 alternate output 0 (TXC).
	01	Parallel Port C bit 3 alternate output 1 (I3).
	10	Parallel Port C bit 3 alternate output 2 (TIMER C3).
	11	Parallel Port C bit 3 alternate output 3 (SCLKD).
5:4	00	Parallel Port C bit 2 alternate output 0 (TXC).
	01	Parallel Port C bit 2 alternate output 1 (I2).
	10	Parallel Port C bit 2 alternate output 2 (TIMER C2).
	11	Parallel Port C bit 2 alternate output 3 (TXF).
3:2	00	Parallel Port C bit 1 alternate output 0 (TXD).
	01	Parallel Port C bit 1 alternate output 1 (I1).
	10	Parallel Port C bit 1 alternate output 2 (TIMER C1).
	11	Parallel Port C bit 1 alternate output 3 (RCLKF).
1:0	00	Parallel Port C bit 0 alternate output 0 (TXD).
	01	Parallel Port C bit 0 alternate output 1 (I0).
	10	Parallel Port C bit 0 alternate output 2 (TIMER C0).
	11	Parallel Port C bit 0 alternate output 3 (TCLKF).

<b>Parallel Port C Alternate High Register (PCAHR) (Address = 0x0053)</b>		
<b>Bit(s)</b>	<b>Value</b>	<b>Description</b>
7:6	00	Parallel Port C bit 7 alternate output 0 (TXA).
	01	Parallel Port C bit 7 alternate output 1 (I7).
	10	Parallel Port C bit 7 alternate output 2 (PWM3).
	11	Parallel Port C bit 7 alternate output 3 (SCLKC).
5:4	00	Parallel Port C bit 6 alternate output 0 (TXA).
	01	Parallel Port C bit 6 alternate output 1 (I6).
	10	Parallel Port C bit 6 alternate output 2 (PWM2).
	11	Parallel Port C bit 6 alternate output 3 (TXE).
3:2	00	Parallel Port C bit 5 alternate output 0 (TXB).
	01	Parallel Port C bit 5 alternate output 1 (I5).
	10	Parallel Port C bit 5 alternate output 2 (PWM1).
	11	Parallel Port C bit 5 alternate output 3 (RCLKE).
1:0	00	Parallel Port C bit 4 alternate output 0 (TXB).
	01	Parallel Port C bit 4 alternate output 1 (I4).
	10	Parallel Port C bit 4 alternate output 2 (PWM0).
	11	Parallel Port C bit 4 alternate output 3 (TCLKE).

<b>Parallel Port C Drive Control Register (PCDCR) (Address = 0x0054)</b>		
<b>Bit(s)</b>	<b>Value</b>	<b>Description</b>
7:0	0	The corresponding port bit, as an output, is driven high and low.
	1	The corresponding port bit, as an output, is open-drain.

<b>Parallel Port C Function Register (PCFR) (Address = 0x0055)</b>		
<b>Bit(s)</b>	<b>Value</b>	<b>Description</b>
7:0	0	The corresponding port bit functions normally.
	1	The corresponding port bit carries its alternate signal as an output. See Table 10-1.

<b>Serial Port x Control Register</b>		
		<b>(SACR)</b> <b>(Address = 0x00C4)</b> <b>(SBCR)</b> <b>(Address = 0x00D4)</b> <b>(SCCR)</b> <b>(Address = 0x00E4)</b> <b>(SDCR)</b> <b>(Address = 0x00F4)</b>
<b>Bit(s)</b>	<b>Value</b>	<b>Description</b>
7:6	00	No operation. These bits are ignored in the asynchronous mode.
	01	In the clocked serial mode, start a byte-receive operation.
	10	In the clocked serial mode, start a byte-transmit operation.
	11	In the clocked serial mode, start a byte-transmit operation and a byte-receive operation simultaneously.
5:4	00	Parallel Port C is used for input.
	01	Parallel Port D is used for input.
	10	Parallel Port E is used for input.
	11	Disable the receiver input.
3:2	00	Asynchronous mode with 8 bits per character.
	01	Asynchronous mode with 7 bits per character. In this mode the most significant bit of a byte is ignored for transmit, and is always zero in receive data.
	10	Clocked serial mode with external clock.
	11	Clocked serial mode with internal clock.
1:0	00	The serial port interrupt is disabled.
	01	The serial port uses Interrupt Priority 1.
	10	The serial port uses Interrupt Priority 2.
	11	The serial port uses Interrupt Priority 3.

<b>Input Capture Source x Register</b>		
		<b>(ICS1R) (ICS2R)</b>
		<b>(Address = 0x0059) (Address = 0x005D)</b>
<b>Bit(s)</b>	<b>Value</b>	<b>Description</b>
7:6	00	Parallel Port C used for Start condition input.
	01	Parallel Port D used for Start condition input.
	10	Parallel Port E used for Start condition input.
	11	This bit combination is reserved and should not be used.
5:4	00	Use port bit 1 for Start condition input.
	01	Use port bit 3 for Start condition input.
	10	Use port bit 5 for Start condition input.
	11	Use port bit 7 for Start condition input.
3:2	00	Parallel Port C used for Stop condition input.
	01	Parallel Port D used for Stop condition input.
	10	Parallel Port E used for Stop condition input.
	11	This bit combination is reserved and should not be used.
1:0	00	Use port bit 1 for Stop condition input.
	01	Use port bit 3 for Stop condition input.
	10	Use port bit 5 for Stop condition input.
	11	Use port bit 7 for Stop condition input.



# 11. PARALLEL PORT D

## 11.1 Overview

Parallel Port D is a byte-wide port with each bit programmable for data direction and drive level. These are simple inputs and outputs controlled and reported in the Port D Data Register (PDDR).

All of the Parallel Port D pins have alternate output functions, and all of them can be used as inputs to various on-chip peripherals.

When used as outputs, the Parallel Port D bits are buffered, with the data written to PDDR transferred to the output pins on a selected timing edge. Either the peripheral clock or the outputs of Timer A1, Timer B1, or Timer B2 can be used for this function, with each nibble of the port having a separate select field to control this timing. Each bit can either be programmed as open-drain or driven high and low.

Because of the buffered nature of Parallel Port D, a read-modify-write type of operation can lead to old data being written to PDDR. To alleviate this potential problem, each bit of the port can be written individually using a separate address for each bit.

**Table 11-1. Parallel Port D Pin Alternate Output Functions**

Pin Name	Alt Out 0	Alt Out 1	Alt Out 2	Alt Out 3
PD7	IA7	I7	PWM3	SCLKC
PD6	TXA	I6	PWM2	TXE
PD5	IA6	I5	PWM1	RCLKE
PD4	TXB	I4	PWM0	TCLKE
PD3	IA7	I3	TIMER C3	SCLKD
PD2	SCLKC	I2	TIMER C2	TXF
PD1	IA6	I1	TIMER C1	RCLKF
PD0	SCLKD	I0	TIMER C0	TCLKF

**Table 11-2. Parallel Port D Pin Alternate Input Functions**

<b>Pin Name</b>	<b>Input Capture</b>	<b>Serial Ports A–D</b>	<b>Serial Ports E–F</b>	<b>DMA</b>	<b>External Interrupts</b>	<b>Quad Decode</b>
PD7	×	RXA	RXE	—	—	—
PD6	—	—	—	—	—	—
PD5	×	RXB	RCLKE	—	—	—
PD4	—	—	TCLKE	—	—	—
PD3	×	RXC	RXF	DREQ1	—	QRD2A
PD2	—	SCLKC	—	DREQ0	—	QRD2B
PD1	×	RXD	RCLKF	—	INT1	QRD1A
PD0	—	SCLKD	TCLKF	—	INT0	QRD1B



## 11.1.1 Block Diagram

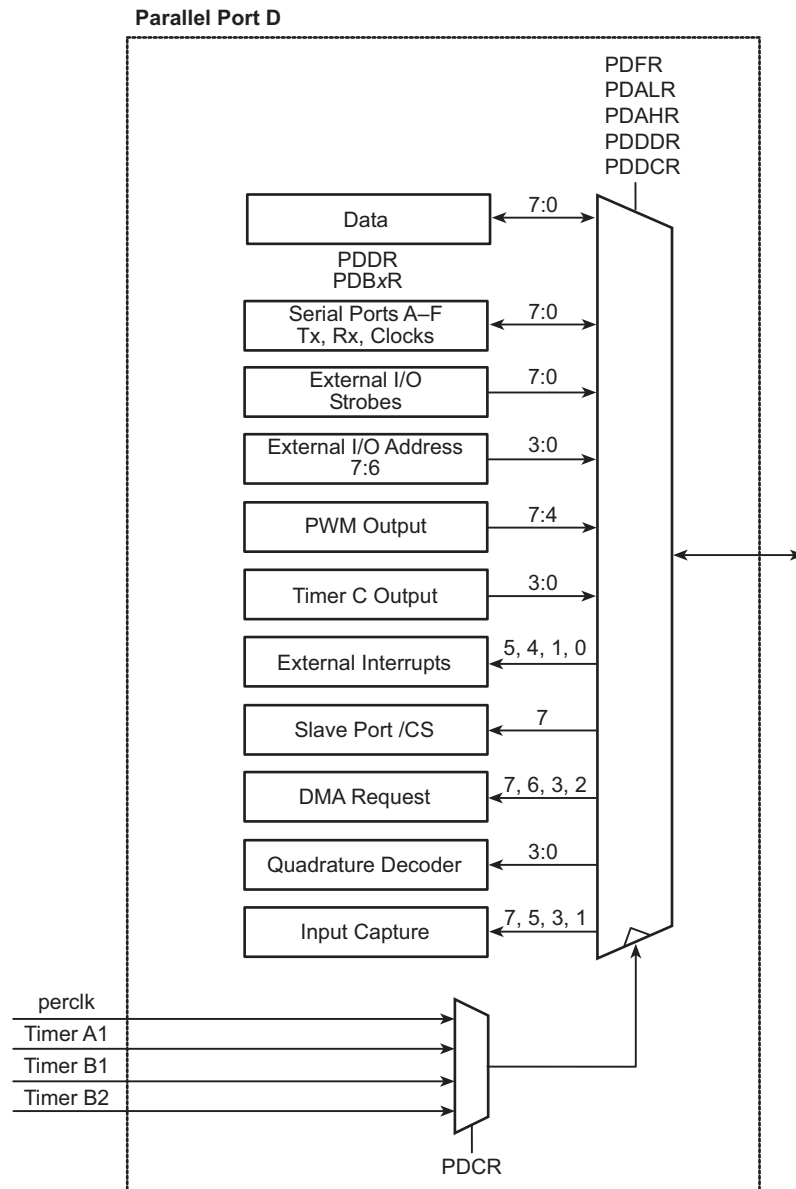

## 11.1.2 Registers

Register Name	Mnemonic	I/O Address	R/W	Reset
Port D Data Register	PDDR	0x0060	R/W	xxxxxxxx
Port D Alternate Low Register	PDALR	0x0062	R/W	00000000
Port D Alternate High Register	PDAHR	0x0063	R/W	00000000
Port D Control Register	PDCR	0x0064	R/W	xx00xx00
Port D Function Register	PDFR	0x0065	R/W	xxxxxxxx
Port D Drive Control Register	PDDCR	0x0066	R/W	xxxxxxxx
Port D Data Direction Register	PDDDR	0x0067	R/W	00000000
Port D Bit 0 Register	PDB0R	0x0068	W	xxxxxxxx
Port D Bit 1 Register	PDB1R	0x0069	W	xxxxxxxx
Port D Bit 2 Register	PDB2R	0x006A	W	xxxxxxxx
Port D Bit 3 Register	PDB3R	0x006B	W	xxxxxxxx
Port D Bit 4 Register	PDB4R	0x006C	W	xxxxxxxx
Port D Bit 5 Register	PDB5R	0x006D	W	xxxxxxxx
Port D Bit 6 Register	PDB6R	0x006E	W	xxxxxxxx
Port D Bit 7 Register	PDB7R	0x006F	W	xxxxxxxx

## 11.2 Dependencies

### 11.2.1 I/O Pins

Parallel Port D uses pins PD0 through PD7. These pins can be used individually as data inputs or outputs; as serial port transmit and receive for Serial Ports A, B, E, and F; as clocks for Serial Ports C–F; as external I/O strobes; or as outputs for the PWM and Timer C peripherals. The input capture peripheral can also watch pins PD7, PD5, PD3, and PD1.

All pins are set as inputs on startup.

The individual bits can be set to be open-drain via PDDCR.

See the associated peripheral chapters for details on how they use Parallel Port D.

### 11.2.2 Clocks

All outputs on Parallel Port D are clocked by the peripheral clock unless changed in PDCR, where the option of updating the Parallel Port D pins can be synchronized to the output of Timer A1, Timer B1, or Timer B2.

### 11.2.3 Other Registers

Register	Function
SACR, SBCR, SCCR, SDCR, SECR, SFCR	Select a Parallel Port D pin as serial data (and optional clock) input.
ICS1R, ICS2R	Select a Parallel Port D pin as a start/stop condition for Input Capture input.
QDCR	Select a Parallel Port D pin as a Quadrature Decoder input.
I0CR, I1CR	Select a Parallel Port D pin as an external interrupt input.
DMR0CR, DMR1CR	Select a Parallel Port D pin as an external DMA request input.

### 11.2.4 Interrupts

External interrupts can be accepted from pins PD1 or PD0; see Chapter 7 for more details.

## 11.3 Operation

The following steps must be taken before using Parallel Port D.

1. Select the desired input/output direction for each pin via PDDDR.
2. Select high/low or open-drain functionality for outputs via PDDCR.
3. If an alternative peripheral output function is desired for a pin, select it via PDALR or PDAHR and then enable it via PDFR. Refer to the appropriate peripheral chapter for further use of that pin.

Once Parallel Port D is set up, data can be read or written by accessing PDDR. Read PDDR to learn the current state of a Parallel Port D pin; any value written to an input pin will not appear on that pin until that pin becomes an output.

## 11.4 Register Descriptions

Parallel Port D Data Register		(PDDR)	(Address = 0x0060)
Bit(s)	Value	Description	
7:0	Read	The current state of Parallel Port D pins PD7–PD0 is reported.	
	Write	The Parallel Port D buffer is written with this value for transfer to the Parallel Port D output register on the next rising edge of the port transfer clock. The port transfer clock is established by PDCR.	

Parallel Port D Alternate Low Register		(PDALR)	(Address = 0x0062)
Bit(s)	Value	Description	
7:6	00	Parallel Port D bit 3 alternate output 0 (IA7).	
	01	Parallel Port D bit 3 alternate output 1 (I3).	
	10	Parallel Port D bit 3 alternate output 2 (TIMER C3).	
	11	Parallel Port D bit 3 alternate output 3 (SCLKD).	
5:4	00	Parallel Port D bit 2 alternate output 0 (SCLKC).	
	01	Parallel Port D bit 2 alternate output 1 (I2).	
	10	Parallel Port D bit 2 alternate output 2 (TIMER C2).	
	11	Parallel Port D bit 2 alternate output 3 (TXF).	
3:2	00	Parallel Port D bit 1 alternate output 0 (IA6).	
	01	Parallel Port D bit 1 alternate output 1 (I1).	
	10	Parallel Port D bit 1 alternate output 2 (TIMER C1).	
	11	Parallel Port D bit 1 alternate output 3 (RCLKF).	
1:0	00	Parallel Port D bit 0 alternate output 0 (SCLKD).	
	01	Parallel Port D bit 0 alternate output 1 (I0).	
	10	Parallel Port D bit 0 alternate output 2 (TIMER C0).	
	11	Parallel Port D bit 0 alternate output 3 (TCLKF).	

<b>Parallel Port D Alternate High Register (PDAHR) (Address = 0x0063)</b>		
<b>Bit(s)</b>	<b>Value</b>	<b>Description</b>
7:6	00	Parallel Port D bit 7 alternate output 0 (IA7).
	01	Parallel Port D bit 7 alternate output 1 (I7).
	10	Parallel Port D bit 7 alternate output 2 (PWM3).
	11	Parallel Port D bit 7 alternate output 3 (SCLKC).
5:4	00	Parallel Port D bit 6 alternate output 0 (TXA).
	01	Parallel Port D bit 6 alternate output 1 (I6).
	10	Parallel Port D bit 6 alternate output 2 (PWM2).
	11	Parallel Port D bit 6 alternate output 3 (TXE).
3:2	00	Parallel Port D bit 5 alternate output 0 (IA6).
	01	Parallel Port D bit 5 alternate output 1 (I5).
	10	Parallel Port D bit 5 alternate output 2 (PWM1).
	11	Parallel Port D bit 5 alternate output 3 (RCLKE).
1:0	00	Parallel Port D bit 4 alternate output 0 (TXB).
	01	Parallel Port D bit 4 alternate output 1 (I4).
	10	Parallel Port D bit 4 alternate output 2 (PWM0).
	11	Parallel Port D bit 4 alternate output 3 (TCLKE).

<b>Parallel Port D Control Register (PDCR) (Address = 0x0064)</b>		
<b>Bit(s)</b>	<b>Value</b>	<b>Description</b>
7:6		These bits are ignored and should be written with zero.
5:4	00	The upper nibble of the port transfer clock is perclk/2.
	01	The upper nibble of the port transfer clock is the output of Timer A1.
	10	The upper nibble of the port transfer clock is the output of Timer B1.
	11	The upper nibble of the port transfer clock is the output of Timer B2.
3:2		These bits are ignored and should be written with zero.
1:0	00	The lower nibble of the port transfer clock is perclk/2.
	01	The lower nibble of the port transfer clock is the output of Timer A1.
	10	The lower nibble of the port transfer clock is the output of Timer B1.
	11	The lower nibble of the port transfer clock is the output of Timer B2.

<b>Parallel Port D Function Register (PDFR) (Address = 0x0065)</b>		
<b>Bit(s)</b>	<b>Value</b>	<b>Description</b>
7:0	0	The corresponding port bit functions normally.
	1	The corresponding port bit carries its alternate signal as an output. See Table 11-1.

<b>Parallel Port D Drive Control Register (PDDCR) (Address = 0x0066)</b>		
<b>Bit(s)</b>	<b>Value</b>	<b>Description</b>
7:0	0	The corresponding port bit, as an output, is driven high and low.
	1	The corresponding port bit, as an output, is open-drain.

<b>Parallel Port D Data Direction Register (PDDDR) (Address = 0x0067)</b>		
<b>Bit(s)</b>	<b>Value</b>	<b>Description</b>
7:0	0	The corresponding port bit is an input.
	1	The corresponding port bit is an output.

<b>Parallel Port D Bit 0 Register (PDB0R) (Address = 0x0068)</b>		
<b>Bit(s)</b>	<b>Value</b>	<b>Description</b>
7:1		These bits are ignored.
0	Write	The port buffer (bit 0) is written with the value of this bit. The port buffer will be transferred to the port output register on the next rising edge of the port transfer clock

<b>Parallel Port D Bit 1 Register (PDB1R) (Address = 0x0069)</b>		
<b>Bit(s)</b>	<b>Value</b>	<b>Description</b>
7:2,0		These bits are ignored.
1	Write	The port buffer (bit 1) is written with the value of this bit. The port buffer will be transferred to the port output register on the next rising edge of the port transfer clock

<b>Parallel Port D Bit 2 Register (PDB2R) (Address = 0x006A)</b>		
<b>Bit(s)</b>	<b>Value</b>	<b>Description</b>
7:3,1:0		These bits are ignored.
2	Write	The port buffer (bit 2) is written with the value of this bit. The port buffer will be transferred to the port output register on the next rising edge of the port transfer clock

<b>Parallel Port D Bit 3 Register (PDB3R) (Address = 0x006B)</b>		
<b>Bit(s)</b>	<b>Value</b>	<b>Description</b>
7:4,2:0		These bits are ignored.
3	Write	The port buffer (bit 3) is written with the value of this bit. The port buffer will be transferred to the port output register on the next rising edge of the port transfer clock

<b>Parallel Port D Bit 4 Register (PDB4R) (Address = 0x006C)</b>		
<b>Bit(s)</b>	<b>Value</b>	<b>Description</b>
7:5,3:0		These bits are ignored.
4	Write	The port buffer (bit 4) is written with the value of this bit. The port buffer will be transferred to the port output register on the next rising edge of the port transfer clock

<b>Parallel Port D Bit 5 Register (PDB5R) (Address = 0x006D)</b>		
<b>Bit(s)</b>	<b>Value</b>	<b>Description</b>
7:6,4:0		These bits are ignored.
5	Write	The port buffer (bit 5) is written with the value of this bit. The port buffer will be transferred to the port output register on the next rising edge of the port transfer clock



<b>Parallel Port D Bit 6 Register (PDB6R) (Address = 0x006E)</b>		
<b>Bit(s)</b>	<b>Value</b>	<b>Description</b>
7,5:0		These bits are ignored.
6	Write	The port buffer (bit 6) is written with the value of this bit. The port buffer will be transferred to the port output register on the next rising edge of the port transfer clock

<b>Parallel Port D Bit 7 Register (PDB7R) (Address = 0x006F)</b>		
<b>Bit(s)</b>	<b>Value</b>	<b>Description</b>
6:0		These bits are ignored.
7	Write	The port buffer (bit 7) is written with the value of this bit. The port buffer will be transferred to the port output register on the next rising edge of the port transfer clock

<b>Serial Port x Control Register</b>		
		<b>(SACR)</b>
		<b>(SBCR)</b>
		<b>(SCCR)</b>
		<b>(SDCR)</b>
		<b>(Address = 0x00C4)</b>
		<b>(Address = 0x00D4)</b>
		<b>(Address = 0x00E4)</b>
		<b>(Address = 0x00F4)</b>
<b>Bit(s)</b>	<b>Value</b>	<b>Description</b>
7:6	00	No operation. These bits are ignored in the asynchronous mode.
	01	In the clocked serial mode, start a byte-receive operation.
	10	In the clocked serial mode, start a byte-transmit operation.
	11	In the clocked serial mode, start a byte-transmit operation and a byte-receive operation simultaneously.
5:4	00	Parallel Port C is used for input.
	01	Parallel Port D is used for input.
	10	Parallel Port E is used for input.
	11	Disable the receiver input.
3:2	00	Asynchronous mode with 8 bits per character.
	01	Asynchronous mode with 7 bits per character. In this mode the most significant bit of a byte is ignored for transmit, and is always zero in receive data.
	10	Clocked serial mode with external clock.
	11	Clocked serial mode with internal clock.
1:0	00	The serial port interrupt is disabled.
	01	The serial port uses Interrupt Priority 1.
	10	The serial port uses Interrupt Priority 2.
	11	The serial port uses Interrupt Priority 3.

<b>Input Capture Source x Register</b>		
		<b>(ICS1R)</b> <b>(ICS2R)</b>
		<b>(Address = 0x0059)</b> <b>(Address = 0x005D)</b>
<b>Bit(s)</b>	<b>Value</b>	<b>Description</b>
7:6	00	Parallel Port C used for Start condition input.
	01	Parallel Port D used for Start condition input.
	10	Parallel Port E used for Start condition input.
	11	This bit combination is reserved and should not be used.
5:4	00	Use port bit 1 for Start condition input.
	01	Use port bit 3 for Start condition input.
	10	Use port bit 5 for Start condition input.
	11	Use port bit 7 for Start condition input.
3:2	00	Parallel Port C used for Stop condition input.
	01	Parallel Port D used for Stop condition input.
	10	Parallel Port E used for Stop condition input.
	11	This bit combination is reserved and should not be used.
1:0	00	Use port bit 1 for Stop condition input.
	01	Use port bit 3 for Stop condition input.
	10	Use port bit 5 for Stop condition input.
	11	Use port bit 7 for Stop condition input.

<b>Quad Decode Control Register (QDCR) (Address = 0x0091)</b>		
<b>Bit(s)</b>	<b>Value</b>	<b>Description</b>
7:6	00	Disable Quadrature Decoder 2 inputs. Writing a new value to these bits will not cause Quadrature Decoder 2 to increment or decrement.
	01	Quadrature Decoder 2 inputs from Parallel Port D bits 3 and 2.
	10	Quadrature Decoder 2 inputs from Parallel Port E bits 3 and 2.
	11	Quadrature Decoder 2 inputs from Parallel Port E bits 7 and 6.
5	0	Eight-bit quadrature decoder counters (both channels).
	1	Ten-bit quadrature decoder counters (both channels).
4		This bit is reserved and should be written as zero.
3:2	00	Disable Quadrature Decoder 1 inputs. Writing a new value to these bits will not cause Quadrature Decoder 1 to increment or decrement.
	01	Quadrature Decoder 1 inputs from Parallel Port D bits 1 and 0.
	10	Quadrature Decoder 1 inputs from Parallel Port E bits 1 and 0.
	11	Quadrature Decoder 1 inputs from Parallel Port E bits 5 and 4.
1:0	00	Quadrature Decoder interrupts are disabled.
	01	Quadrature Decoder interrupt use Interrupt Priority 1.
	10	Quadrature Decoder interrupt use Interrupt Priority 2.
	11	Quadrature Decoder interrupt use Interrupt Priority 3.

<b>Interrupt x Control Register</b>		<b>(I0CR)</b>	<b>(Address = 0x0098)</b>
		<b>(I1CR)</b>	<b>(Address = 0x0099)</b>
<b>Bit(s)</b>	<b>Value</b>	<b>Description</b>	
7:6	00	Parallel Port D low nibble interrupt disabled.	
	01	Parallel Port D low nibble interrupt on falling edge.	
	10	Parallel Port D low nibble interrupt on rising edge.	
	11	Parallel Port D low nibble interrupt on both edges.	
5:4	00	Parallel Port E high nibble interrupt disabled.	
	01	Parallel Port E high nibble interrupt on falling edge.	
	10	Parallel Port E high nibble interrupt on rising edge.	
	11	Parallel Port E high nibble interrupt on both edges.	
3:2	00	Parallel Port E low nibble interrupt disabled.	
	01	Parallel Port E low nibble interrupt on falling edge.	
	10	Parallel Port E low nibble interrupt on rising edge.	
	11	Parallel Port E low nibble interrupt on both edges.	
1:0	00	This external interrupt is disabled.	
	01	This external interrupt uses Interrupt Priority 1.	
	10	This external interrupt uses Interrupt Priority 2.	
	11	This external interrupt uses Interrupt Priority 3.	

<b>DMA Master Request 0 Control Register (DMR0CR) (Address = 0x0106)</b>		
<b>Bit(s)</b>	<b>Value</b>	<b>Description</b>
7:6	00	External DMA Request 0 disabled.
	01	External DMA Request 0 enabled from Parallel Port D2.
	10	External DMA Request 0 enabled from Parallel Port E2.
	11	External DMA Request 0 enabled from Parallel Port E6.
5		This bit is reserved and should be written with zero.
4:3	00	External DMA Request 0 falling-edge triggered. One transfer per request.
	01	External DMA Request 0 rising-edge triggered. One transfer per request.
	10	External DMA Request 0 active low. Transfers continue while low.
	11	External DMA Request 0 active high. Transfers continue while high.
2:0	000	External DMA Request 0 supplied to DMA Channel 0.
	001	External DMA Request 0 supplied to DMA Channel 1.
	010	External DMA Request 0 supplied to DMA Channel 2.
	011	External DMA Request 0 supplied to DMA Channel 3.
	100	External DMA Request 0 supplied to DMA Channel 4.
	101	External DMA Request 0 supplied to DMA Channel 5.
	110	External DMA Request 0 supplied to DMA Channel 6.
	111	External DMA Request 0 supplied to DMA Channel 7.

<b>DMA Master Request 1 Control Register (DMR1CR) (Address = 0x0107)</b>		
<b>Bit(s)</b>	<b>Value</b>	<b>Description</b>
7:6	00	External DMA Request 1 disabled.
	01	External DMA Request 1 enabled from Parallel Port D3.
	10	External DMA Request 1 enabled from Parallel Port E3.
	11	External DMA Request 1 enabled from Parallel Port E7.
5		This bit is reserved and should be written with zero.
4:3	00	External DMA Request 1 falling edge triggered. One byte per request.
	01	External DMA Request 1 rising edge triggered. One transfer per request.
	10	External DMA Request 1 active low. Transfers continue while low.
	11	External DMA Request 1 active high. Transfers continue while high.
2:0	000	External DMA Request 1 supplied to DMA Channel 0.
	001	External DMA Request 1 supplied to DMA Channel 1.
	010	External DMA Request 1 supplied to DMA Channel 2.
	011	External DMA Request 1 supplied to DMA Channel 3.
	100	External DMA Request 1 supplied to DMA Channel 4.
	101	External DMA Request 1 supplied to DMA Channel 5.
	110	External DMA Request 1 supplied to DMA Channel 6.
	111	External DMA Request 1 supplied to DMA Channel 7.





# 12. PARALLEL PORT E

## 12.1 Overview

Parallel Port E is a byte-wide port with each bit programmable for data direction and drive level. These are simple inputs and outputs controlled and reported in the Port E Data Register (PEDR).

All of the Parallel Port E pins have alternate output functions, and all of them can be used as inputs to various on-chip peripherals.

When used as outputs, the Parallel Port E bits are buffered, with the data written to PEDR transferred to the output pins on a selected timing edge. Either the peripheral clock or the outputs of Timer A1, Timer B1, or Timer B2 can be used for this function, with each nibble of the port having a separate select field to control this timing. Each bit can either be programmed as open-drain or driven high and low.

Because of the buffered nature of Parallel Port E, using a read-modify-write type of operation can lead to old data being written to PEDR. To alleviate this potential problem, each bit of the port can be written individually using a separate address for each bit.

Bit 7 of Parallel Port E is used as the default chip select input for the slave port when the slave port is enabled, either for parallel bootstrap or under program control.

**Table 12-1. Parallel Port E Pin Alternate Output Functions**

Pin Name	Alt Out 0	Alt Out 1	Alt Out 2	Alt Out 3
PE7	I7	—	PWM3	SCLKC
PE6	I6	—	PWM2	TXE
PE5	I5	—	PWM1	RCLKC
PE4	I4	/A0	PWM0	TCLKC
PE3	I3	A23	TIMER C3	SCLKD
PE2	I2	A22	TIMER C2	TXF
PE1	I1	A21	TIMER C1	RCLKF
PE0	I0	A20	TIMER C0	TCLKF

**Table 12-2. Parallel Port E Pin Alternate Input Functions**

Pin Name	Input Capture	I/O Handshake	Serial Ports A–D	Serial Ports E–F	DMA	External Interrupts	Quad Decode
PE7	×	×	RXA	RXE	DREQ1	—	—
PE6	—	×	—	—	DREQ0	—	—
PE5	×	×	RXB	RCLKE	—	INT1	—
PE4	—	×	—	TCLKE	—	INT0	—
PE3	×	×	RXC	RXF	DREQ1	—	QRD2A
PE2	—	×	SCLKC	—	DREQ0	—	QRD2B
PE1	×	×	RXD	RCLKF	—	INT1	QRD1A
PE0	—	×	SCLKD	TCLKF	—	INT0	QRD1B

## 12.1.1 Block Diagram

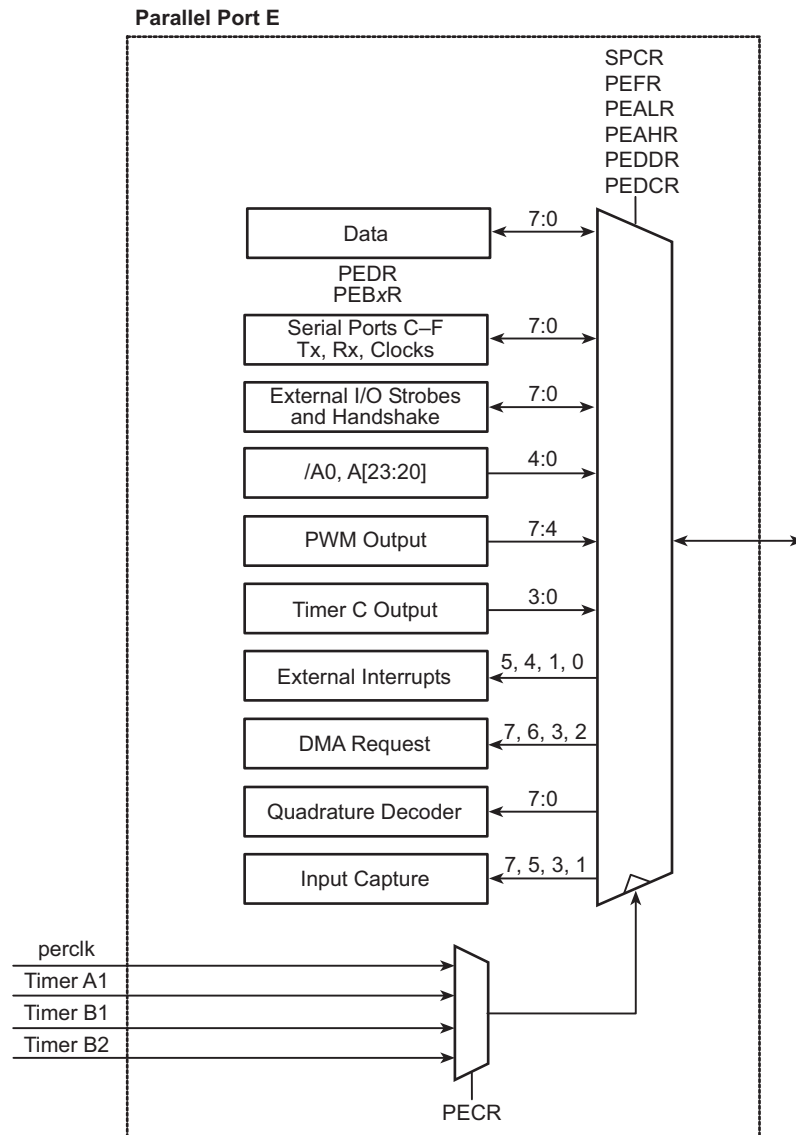

## 12.1.2 Registers

Register Name	Mnemonic	I/O Address	R/W	Reset
Port E Data Register	PEDR	0x0070	R/W	xxxxxxxx
Port E Alternate Low Register	PEALR	0x0072	R/W	00000000
Port E Alternate High Register	PEAHR	0x0073	R/W	00000000
Port E Control Register	PECR	0x0074	R/W	xx00xx00
Port E Function Register	PEFR	0x0075	R/W	00000000
Port E Drive Control Register	PEDCR	0x0076	R/W	00000000
Port E Data Direction Register	PEDDR	0x0077	R/W	00000000
Port E Bit 0 Register	PEB0R	0x0078	W	xxxxxxxx
Port E Bit 1 Register	PEB1R	0x0079	W	xxxxxxxx
Port E Bit 2 Register	PEB2R	0x007A	W	xxxxxxxx
Port E Bit 3 Register	PEB3R	0x007B	W	xxxxxxxx
Port E Bit 4 Register	PEB4R	0x007C	W	xxxxxxxx
Port E Bit 5 Register	PEB5R	0x007D	W	xxxxxxxx
Port E Bit 6 Register	PEB6R	0x007E	W	xxxxxxxx
Port E Bit 7 Register	PEB7R	0x007F	W	xxxxxxxx

## 12.2 Dependencies

### 12.2.1 I/O Pins

Parallel Port E uses the pins PE0 through PE7. These pins can be used individually as data inputs or outputs; as serial port transmit and receive for Serial Ports E and F; as clocks for Serial Ports C–F; as external I/O strobes; as outputs for the PWM and Timer C peripherals; or as the upper address bits A[23:20]. The input capture peripheral can also watch pins PE7, PE5, PE3, and PE1. There is also an option to provide the slave port chip select on PE7.

All pins are set as inputs on startup.

The individual bits can be set to be open-drain via PEDCR.

See the associated peripheral chapters for details on how they use Parallel Port E.

### 12.2.2 Clocks

All outputs on Parallel Port E are clocked by the peripheral clock unless changed in PECR, where the option of updating the Parallel Port E pins can be synchronized to the output of Timer A1, Timer B1, or Timer B2.

### 12.2.3 Other Registers

Register	Function
SACR, SBCR, SCCR, SDCR, SECR, SFCR	Select a Parallel Port E pin as serial data (and optional clock) input.
ICS1R, ICS2R	Select a Parallel Port E pin as a start/stop condition for Input Capture input.
QDCR	Select a Parallel Port E pin as a Quadrature Decoder input.
I0CR, I1CR	Select a Parallel Port E pin as an external interrupt input.
DMR0CR, DMR1CR	Select a Parallel Port E pin as an external DMA request input.
SPCR	Select slave chip select on PE7.
IHCR, IHSR, IHTR	Select a Parallel Port E pin for I/O handshake.

### 12.2.4 Interrupts

External interrupts can be accepted from pins PE5, PE4, PE1 or PE0; see Chapter 7 for more details.

## 12.3 Operation

The following steps must be taken before using Parallel Port E.

1. Select the desired input/output direction for each pin via PEDDR.
2. Select high/low or open-drain functionality for outputs via PEDCR.
3. If an alternative peripheral output function is desired for a pin, select it via PEALR or PEahr and then enable it via PEFr. Refer to the appropriate peripheral chapter for further use of that pin.

Once the port is set up, data can be read or written by accessing PEDR. Read PEDR to learn the current state of a Parallel Port E pin; any value written to an input pin will not appear on that pin until that pin becomes an output.

## 12.4 Register Descriptions

<b>Parallel Port E Data Register (PEDR) (Address = 0x0070)</b>		
<b>Bit(s)</b>	<b>Value</b>	<b>Description</b>
7:0	Read	The current state of Parallel Port E pins PE7–PE0 is reported.
	Write	The Parallel Port E buffer is written with this value for transfer to the Parallel Port E output register on the next rising edge of the port transfer clock. The port transfer clock is established by PECR.

<b>Parallel Port E Alternate Low Register (PEALR) (Address = 0x0072)</b>		
<b>Bit(s)</b>	<b>Value</b>	<b>Description</b>
7:6	00	Parallel Port E bit 3 alternate output 0 (I3).
	01	Parallel Port E bit 3 alternate output 1 (A23).
	10	Parallel Port E bit 3 alternate output 2 (TIMER C3).
	11	Parallel Port E bit 3 alternate output 3 (SCLKD).
5:4	00	Parallel Port E bit 2 alternate output 0 (I2).
	01	Parallel Port E bit 2 alternate output 1 (A22).
	10	Parallel Port E bit 2 alternate output 2 (TIMER C2).
	11	Parallel Port E bit 2 alternate output 3 (TXF).
3:2	00	Parallel Port E bit 1 alternate output 0 (I1).
	01	Parallel Port E bit 1 alternate output 1 (A21).
	10	Parallel Port E bit 1 alternate output 2 (TIMER C1).
	11	Parallel Port E bit 1 alternate output 3 (RCLKF).
1:0	00	Parallel Port E bit 0 alternate output 0 (I0).
	01	Parallel Port E bit 0 alternate output 1 (A20).
	10	Parallel Port E bit 0 alternate output 2 (TIMER C0).
	11	Parallel Port E bit 0 alternate output 3 (TCLKF).

<b>Parallel Port E Alternate High Register (PEAHR) (Address = 0x0073)</b>		
<b>Bit(s)</b>	<b>Value</b>	<b>Description</b>
7:6	00	Parallel Port E bit 7 alternate output 0 (I7).
	01	Parallel Port E bit 7 alternate output 1 (no functionality).
	10	Parallel Port E bit 7 alternate output 2 (PWM3).
	11	Parallel Port E bit 7 alternate output 3 (SCLKC).
5:4	00	Parallel Port E bit 6 alternate output 0 (I6).
	01	Parallel Port E bit 6 alternate output 1 (no functionality).
	10	Parallel Port E bit 6 alternate output 2 (PWM2).
	11	Parallel Port E bit 6 alternate output 3 (TXE).
3:2	00	Parallel Port E bit 5 alternate output 0 (I5).
	01	Parallel Port E bit 5 alternate output 1 (no functionality).
	10	Parallel Port E bit 5 alternate output 2 (PWM1).
	11	Parallel Port E bit 5 alternate output 3 RCLKE).
1:0	00	Parallel Port E bit 4 alternate output 0 (I4).
	01	Parallel Port E bit 4 alternate output 1 (/A0).
	10	Parallel Port E bit 4 alternate output 2 (PWM0).
	11	Parallel Port E bit 4 alternate output 3 (TCLKE).

<b>Parallel Port E Control Register (PECR) (Address = 0x0074)</b>		
<b>Bit(s)</b>	<b>Value</b>	<b>Description</b>
7:6		These bits are ignored and should be written with zero.
5:4	00	The upper nibble peripheral clock is perclk/2.
	01	The upper nibble peripheral clock is the output of Timer A1.
	10	The upper nibble peripheral clock is the output of Timer B1.
	11	The upper nibble peripheral clock is the output of Timer B2.
3:2		These bits are ignored and should be written with zero.
1:0	00	The lower nibble peripheral clock is perclk/2.
	01	The lower nibble peripheral clock is the output of Timer A1.
	10	The lower nibble peripheral clock is the output of Timer B1.
	11	The lower nibble peripheral clock is the output of Timer B2.

<b>Parallel Port E Function Register (PEFR) (Address = 0x0075)</b>		
<b>Bit(s)</b>	<b>Value</b>	<b>Description</b>
7:0	0	The corresponding port bit functions normally.
	1	The corresponding port bit carries its alternate signal as an output. See Table 12-1.

<b>Parallel Port E Drive Control Register (PEDCR) (Address = 0x0076)</b>		
<b>Bit(s)</b>	<b>Value</b>	<b>Description</b>
7:0	0	The corresponding port bit, as an output, is driven high and low.
	1	The corresponding port bit, as an output, is open-drain.

<b>Parallel Port E Data Direction Register (PEDDR) (Address = 0x0077)</b>		
<b>Bit(s)</b>	<b>Value</b>	<b>Description</b>
7:0	0	The corresponding port bit is an input.
	1	The corresponding port bit is an output.

<b>Parallel Port E Bit 0 Register (PEB0R) (Address = 0x0078)</b>		
<b>Bit(s)</b>	<b>Value</b>	<b>Description</b>
7:1		These bits are ignored.
0	Write	The port buffer (bit 0) is written with the value of this bit. The port buffer will be transferred to the port output register on the next rising edge of the peripheral clock.

<b>Parallel Port E Bit 1 Register (PEB1R) (Address = 0x0079)</b>		
<b>Bit(s)</b>	<b>Value</b>	<b>Description</b>
7:2,0		These bits are ignored.
1	Write	The port buffer (bit 1) is written with the value of this bit. The port buffer will be transferred to the port output register on the next rising edge of the peripheral clock.



<b>Parallel Port E Bit 2 Register (PEB2R) (Address = 0x007A)</b>		
<b>Bit(s)</b>	<b>Value</b>	<b>Description</b>
7:3,1:0		These bits are ignored.
2	Write	The port buffer (bit 2) is written with the value of this bit. The port buffer will be transferred to the port output register on the next rising edge of the peripheral clock.

<b>Parallel Port E Bit 3 Register (PEB3R) (Address = 0x007B)</b>		
<b>Bit(s)</b>	<b>Value</b>	<b>Description</b>
7:4,2:0		These bits are ignored.
3	Write	The port buffer (bit 3) is written with the value of this bit. The port buffer will be transferred to the port output register on the next rising edge of the peripheral clock.

<b>Parallel Port E Bit 4 Register (PEB4R) (Address = 0x007C)</b>		
<b>Bit(s)</b>	<b>Value</b>	<b>Description</b>
7:5,3:0		These bits are ignored.
4	Write	The port buffer (bit 4) is written with the value of this bit. The port buffer will be transferred to the port output register on the next rising edge of the peripheral clock.

<b>Parallel Port E Bit 5 Register (PEB5R) (Address = 0x007D)</b>		
<b>Bit(s)</b>	<b>Value</b>	<b>Description</b>
7:6,4:0		These bits are ignored.
5	Write	The port buffer (bit 5) is written with the value of this bit. The port buffer will be transferred to the port output register on the next rising edge of the peripheral clock.

<b>Parallel Port E Bit 6 Register (PEB6R) (Address = 0x007E)</b>		
<b>Bit(s)</b>	<b>Value</b>	<b>Description</b>
7,5:0		These bits are ignored.
6	Write	The port buffer (bit 6) is written with the value of this bit. The port buffer will be transferred to the port output register on the next rising edge of the peripheral clock.

<b>Parallel Port E Bit 7 Register (PEB7R) (Address = 0x007F)</b>		
<b>Bit(s)</b>	<b>Value</b>	<b>Description</b>
6:0		These bits are ignored.
7	Write	The port buffer (bit 7) is written with the value of this bit. The port buffer will be transferred to the port output register on the next rising edge of the peripheral clock.

<b>Serial Port x Control Register</b>		
		<b>(SACR)</b>
		<b>(SBCR)</b>
		<b>(SCCR)</b>
		<b>(SDCR)</b>
		<b>(Address = 0x00C4)</b>
		<b>(Address = 0x00D4)</b>
		<b>(Address = 0x00E4)</b>
		<b>(Address = 0x00F4)</b>
<b>Bit(s)</b>	<b>Value</b>	<b>Description</b>
7:6	00	No operation. These bits are ignored in the asynchronous mode.
	01	In the clocked serial mode, start a byte-receive operation.
	10	In the clocked serial mode, start a byte-transmit operation.
	11	In the clocked serial mode, start a byte-transmit operation and a byte-receive operation simultaneously.
5:4	00	Parallel Port C is used for input.
	01	Parallel Port D is used for input.
	10	Parallel Port E is used for input.
	11	Disable the receiver input.
3:2	00	Asynchronous mode with 8 bits per character.
	01	Asynchronous mode with 7 bits per character. In this mode the most significant bit of a byte is ignored for transmit, and is always zero in receive data.
	10	Clocked serial mode with external clock.
	11	Clocked serial mode with internal clock.
1:0	00	The serial port interrupt is disabled.
	01	The serial port uses Interrupt Priority 1.
	10	The serial port uses Interrupt Priority 2.
	11	The serial port uses Interrupt Priority 3.

<b>Input Capture Source x Register</b>		<b>(ICS1R)</b>	<b>(Address = 0x0059)</b>
		<b>(ICS2R)</b>	<b>(Address = 0x005D)</b>
<b>Bit(s)</b>	<b>Value</b>	<b>Description</b>	
7:6	00	Parallel Port C used for Start condition input.	
	01	Parallel Port D used for Start condition input.	
	10	Parallel Port E used for Start condition input.	
	11	This bit combination is reserved and should not be used.	
5:4	00	Use port bit 1 for Start condition input.	
	01	Use port bit 3 for Start condition input.	
	10	Use port bit 5 for Start condition input.	
	11	Use port bit 7 for Start condition input.	
3:2	00	Parallel Port C used for Stop condition input.	
	01	Parallel Port D used for Stop condition input.	
	10	Parallel Port E used for Stop condition input.	
	11	This bit combination is reserved and should not be used.	
1:0	00	Use port bit 1 for Stop condition input.	
	01	Use port bit 3 for Stop condition input.	
	10	Use port bit 5 for Stop condition input.	
	11	Use port bit 7 for Stop condition input.	

<b>Quad Decode Control Register (QDCR) (Address = 0x0091)</b>		
<b>Bit(s)</b>	<b>Value</b>	<b>Description</b>
7:6	00	Disable Quadrature Decoder 2 inputs. Writing a new value to these bits will not cause Quadrature Decoder 2 to increment or decrement.
	01	Quadrature Decoder 2 inputs from Parallel Port D bits 3 and 2.
	10	Quadrature Decoder 2 inputs from Parallel Port E bits 3 and 2.
	11	Quadrature Decoder 2 inputs from Parallel Port E bits 7 and 6.
5	0	Eight-bit quadrature decoder counters (both channels).
	1	Ten-bit quadrature decoder counters (both channels).
4		This bit is reserved and should be written as zero.
3:2	00	Disable Quadrature Decoder 1 inputs. Writing a new value to these bits will not cause Quadrature Decoder 1 to increment or decrement.
	01	Quadrature Decoder 1 inputs from Parallel Port D bits 1 and 0.
	10	Quadrature Decoder 1 inputs from Parallel Port E bits 1 and 0.
	11	Quadrature Decoder 1 inputs from Parallel Port E bits 5 and 4.
1:0	00	Quadrature Decoder interrupts are disabled.
	01	Quadrature Decoder interrupt use Interrupt Priority 1.
	10	Quadrature Decoder interrupt use Interrupt Priority 2.
	11	Quadrature Decoder interrupt use Interrupt Priority 3.

<b>Interrupt x Control Register</b>		<b>(I0CR)</b>	<b>(Address = 0x0098)</b>
		<b>(I1CR)</b>	<b>(Address = 0x0099)</b>
<b>Bit(s)</b>	<b>Value</b>	<b>Description</b>	
7:6	00	Parallel Port D low nibble interrupt disabled.	
	01	Parallel Port D low nibble interrupt on falling edge.	
	10	Parallel Port D low nibble interrupt on rising edge.	
	11	Parallel Port D low nibble interrupt on both edges.	
5:4	00	Parallel Port E high nibble interrupt disabled.	
	01	Parallel Port E high nibble interrupt on falling edge.	
	10	Parallel Port E high nibble interrupt on rising edge.	
	11	Parallel Port E high nibble interrupt on both edges.	
3:2	00	Parallel Port E low nibble interrupt disabled.	
	01	Parallel Port E low nibble interrupt on falling edge.	
	10	Parallel Port E low nibble interrupt on rising edge.	
	11	Parallel Port E low nibble interrupt on both edges.	
1:0	00	This external interrupt is disabled.	
	01	This external interrupt uses Interrupt Priority 1.	
	10	This external interrupt uses Interrupt Priority 2.	
	11	This external interrupt uses Interrupt Priority 3.	

<b>DMA Master Request 0 Control Register (DMR0CR) (Address = 0x0106)</b>		
<b>Bit(s)</b>	<b>Value</b>	<b>Description</b>
7:6	00	External DMA Request 0 disabled.
	01	External DMA Request 0 enabled from Parallel Port D2.
	10	External DMA Request 0 enabled from Parallel Port E2.
	11	External DMA Request 0 enabled from Parallel Port E6.
5		This bit is reserved and should be written with zero.
4:3	00	External DMA Request 0 falling-edge triggered. One transfer per request.
	01	External DMA Request 0 rising-edge triggered. One transfer per request.
	10	External DMA Request 0 active low. Transfers continue while low.
	11	External DMA Request 0 active high. Transfers continue while high.
2:0	000	External DMA Request 0 supplied to DMA Channel 0.
	001	External DMA Request 0 supplied to DMA Channel 1.
	010	External DMA Request 0 supplied to DMA Channel 2.
	011	External DMA Request 0 supplied to DMA Channel 3.
	100	External DMA Request 0 supplied to DMA Channel 4.
	101	External DMA Request 0 supplied to DMA Channel 5.
	110	External DMA Request 0 supplied to DMA Channel 6.
	111	External DMA Request 0 supplied to DMA Channel 7.

<b>DMA Master Request 1 Control Register (DMR1CR) (Address = 0x0107)</b>		
<b>Bit(s)</b>	<b>Value</b>	<b>Description</b>
7:6	00	External DMA Request 1 disabled.
	01	External DMA Request 1 enabled from Parallel Port D3.
	10	External DMA Request 1 enabled from Parallel Port E3.
	11	External DMA Request 1 enabled from Parallel Port E7.
5		This bit is reserved and should be written with zero.
4:3	00	External DMA Request 1 falling edge triggered. One byte per request.
	01	External DMA Request 1 rising edge triggered. One transfer per request.
	10	External DMA Request 1 active low. Transfers continue while low.
	11	External DMA Request 1 active high. Transfers continue while high.
2:0	000	External DMA Request 1 supplied to DMA Channel 0.
	001	External DMA Request 1 supplied to DMA Channel 1.
	010	External DMA Request 1 supplied to DMA Channel 2.
	011	External DMA Request 1 supplied to DMA Channel 3.
	100	External DMA Request 1 supplied to DMA Channel 4.
	101	External DMA Request 1 supplied to DMA Channel 5.
	110	External DMA Request 1 supplied to DMA Channel 6.
	111	External DMA Request 1 supplied to DMA Channel 7.



<b>Slave Port Control Register (SPCR) (Address = 0x0024)</b>		
<b>Bit(s)</b>	<b>Value</b>	<b>Description</b>
7	0	Program fetch as a function of the SMODE pins.
	1	Ignore the SMODE pins program fetch function.
6:5	Read	These bits report the state of the SMODE pins.
	Write	These bits are ignored and should be written with zero.
4:2	000	Disable the slave port. Parallel Port A is a byte-wide input port.
	001	Disable the slave port. Parallel Port A is a byte-wide output port.
	010	Enable the slave port, with /SCS from Parallel Port E bit 7.
	011	Enable the external I/O bus. Parallel Port A is used for the data bus and Parallel Port B[7:2] is used for the address bus.
	100	This bit combination is reserved and should not be used.
	101	This bit combination is reserved and should not be used.
	110	Enable the slave port, with /SCS from Parallel Port B bit 6.
	111	Enable the external I/O bus. Parallel Port A is used for the data bus and Parallel Port B[7:0] is used for the address bus.
1:0	00	Slave port interrupts are disabled.
	01	Slave port interrupts use Interrupt Priority 1.
	10	Slave port interrupts use Interrupt Priority 2.
	11	Slave port interrupts use Interrupt Priority 3.

<b>I/O Handshake Control Register (IHCR) (Address = 0x0028)</b>		
<b>Bit(s)</b>	<b>Value</b>	<b>Description</b>
7:5		These bits are reserved and should be written with zeros.
4	0	I/O handshake is active low (I/O transaction held until signal goes high).
	1	I/O handshake is active high (I/O transaction held until signal goes low).
3		This bit is reserved and should be written with zero.
2:0	000	Use Parallel Port E bit 0 for I/O handshake.
	001	Use Parallel Port E bit 1 for I/O handshake.
	010	Use Parallel Port E bit 2 for I/O handshake.
	011	Use Parallel Port E bit 3 for I/O handshake.
	100	Use Parallel Port E bit 4 for I/O handshake.
	101	Use Parallel Port E bit 5 for I/O handshake.
	110	Use Parallel Port E bit 6 for I/O handshake.
	111	Use Parallel Port E bit 7 for I/O handshake.

<b>I/O Handshake Select Register</b>		<b>(IHSR)</b>	<b>(Address = 0x0029)</b>
<b>Bit(s)</b>	<b>Value</b>	<b>Description</b>	
7	0	Disable I/O handshake for I/O Bank 7.	
	1	Enable I/O handshake for I/O Bank 7.	
6	0	Disable I/O handshake for I/O Bank 6.	
	1	Enable I/O handshake for I/O Bank 6.	
5	0	Disable I/O handshake for I/O Bank 5.	
	1	Enable I/O handshake for I/O Bank 5.	
4	0	Disable I/O handshake for I/O Bank 4.	
	1	Enable I/O handshake for I/O Bank 4.	
3	0	Disable I/O handshake for I/O Bank 3.	
	1	Enable I/O handshake for I/O Bank 3.	
2	0	Disable I/O handshake for I/O Bank 2.	
	1	Enable I/O handshake for I/O Bank 2.	
1	0	Disable I/O handshake for I/O Bank 1.	
	1	Enable I/O handshake for I/O Bank 1.	
0	0	Disable I/O handshake for I/O Bank 0.	
	1	Enable I/O handshake for I/O Bank 0.	

<b>I/O Handshake Timeout Register</b>		<b>(IHTR)</b>	<b>(Address = 0x002A)</b>
<b>Bit(s)</b>	<b>Value</b>	<b>Description</b>	
7	0	No I/O handshake timeout has occurred since the last read of this register.	
	1	An I/O handshake timeout has occurred since the last read of this register. This bit is cleared by a read of this register.	
6		This bit is reserved and should be written with zero.	
5:0		Time constant for the I/O handshake timeout counter. This time constant (times 32) selects the number of clocks that the I/O handshake input may delay completion of an I/O transaction before the I/O transaction will complete automatically.	



# 13. PARALLEL PORT H

## 13.1 Overview

Parallel Port H is a byte-wide port with each bit programmable for data direction and drive level. These are simple inputs and outputs controlled and reported in the Port H Data Register (PHDR).

All of the Parallel Port H pins have alternate output functions.

When used as outputs, the Parallel Port H bits are buffered, with the data written to PHDR transferred to the output pins. Each bit can either be programmed as open-drain or driven high and low.

Parallel Port H acts as the upper byte of the data bus when the 16-bit mode is enabled; all other Parallel Port H functionality will be disabled automatically when the 16-bit mode is in effect.

Parallel Port H has no alternate input functionality.

**Table 13-1. Parallel Port H Pin Alternate Output Functions**

Pin Name	Alt Out 0	Alt Out 1	Alt Out 2	Alt Out 3	16-bit Data Bus
PH7	—	I7	PWM3	SCLKC	D15
PH6	—	I6	PWM2	TXE	D14
PH5	—	I5	PWM1	RCLKE	D13
PH4	—	I4	PWM0	TCLKE	D12
PH3	—	I3	TIMER C3	SCLKD	D11
PH2	—	I2	TIMER C2	TXF	D10
PH1	—	I1	TIMER C1	RCLKF	D9
PH0	—	I0	TIMER C0	TCLKF	D8

### 13.1.1 Block Diagram

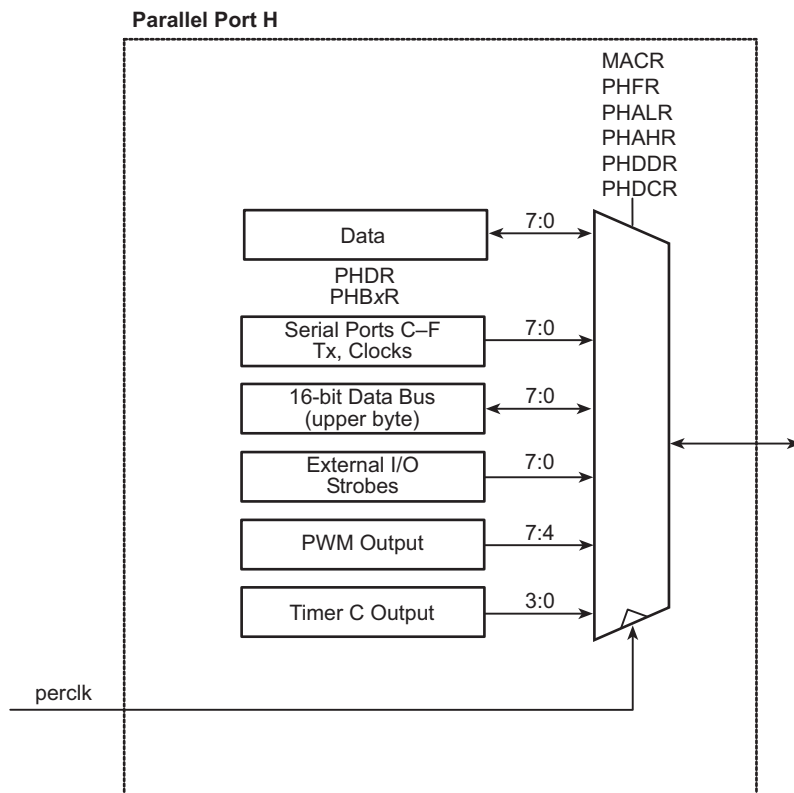

### 13.1.2 Registers

Register Name	Mnemonic	I/O Address	R/W	Reset
Port H Data Register	PHDR	0x0034	R/W	00000000
Port H Alternate Low Register	PHALR	0x0032	R/W	00000000
Port H Alternate High Register	PHAHR	0x0033	R/W	00000000
Port H Function Register	PHFR	0x0035	R/W	00000000
Port H Drive Control Register	PHDCR	0x0036	R/W	00000000
Port H Data Direction Register	PHDDR	0x0037	R/W	00000000

## 13.2 Dependencies

### 13.2.1 I/O Pins

Parallel Port H uses pins PH0 through PH7. These pins can be used individually as data inputs or outputs; as the serial port transmit for Serial Ports E and F; as the clock transmit (internal clock mode) for Serial Ports C–F; as external I/O strobes; or as outputs for the PWM and Timer C peripherals. In addition, Parallel Port H acts as the upper byte of the data bus (D[15:8]) when 16-bit addressing is enabled.

All pins are set as inputs on startup.

The individual bits can be set to be open-drain via PHDCR.

See the associated peripheral chapters for details on how they use Parallel Port H.

### 13.2.2 Clocks

All outputs on Parallel Port H are clocked by the peripheral clock.

### 13.2.3 Other Registers

Register	Function
MACR	Enable 16-bit data bus.

### 13.2.4 Interrupts

There are no interrupts associated with Parallel Port H.

## 13.3 Operation

The following steps must be taken before using Parallel Port H.

1. Select the desired input/output direction for each pin via PHDDR.
2. Select high/low or open-drain functionality for outputs via PHDCR.
3. If an alternative peripheral output function is desired for a pin, select it via PHALR or PHAHR and then enable it via PHFR. Refer to the appropriate peripheral chapter for further use of that pin.
4. All these settings will be superseded if a 16-bit memory interface is selected since Parallel Port H is used for the upper half of the data bus in that mode.

Once Parallel Port H is set up, data can be read or written by accessing PHDR. The value of an output pin read in from PHDR will reflect its current output value, but any value written to an input pin will not appear on that pin until that pin becomes an output.

## 13.4 Register Descriptions

Parallel Port H Data Register (PHDR) (Address = 0x0034)		
Bit(s)	Value	Description
7:0	Read	The current state of Parallel Port H pins PH7–PH0 is reported.
	Write	The Parallel Port H buffer is written with this value for transfer to the Parallel Port H output register on the next rising edge of the peripheral clock.

Parallel Port H Alternate Low Register (PHALR) (Address = 0x0032)		
Bit(s)	Value	Description
7:6	00	This value is reserved and must not be used.
	01	Parallel Port H bit 3 alternate output 1 (I3).
	10	Parallel Port H bit 3 alternate output 2 (TIMER C3).
	11	Parallel Port H bit 3 alternate output 3 (SCLKD).
5:4	00	This value is reserved and must not be used.
	01	Parallel Port H bit 2 alternate output 1 (I2).
	10	Parallel Port H bit 2 alternate output 2 (TIMER C2).
	11	Parallel Port H bit 2 alternate output 3 (TXF).
3:2	00	This value is reserved and must not be used.
	01	Parallel Port H bit 1 alternate output 1 (I1).
	10	Parallel Port H bit 1 alternate output 2 (TIMER C1).
	11	Parallel Port H bit 1 alternate output 3 (RCLKF).
1:0	00	This value is reserved and must not be used.
	01	Parallel Port H bit 0 alternate output 1 (I0).
	10	Parallel Port H bit 0 alternate output 2 (TIMER C0).
	11	Parallel Port H bit 0 alternate output 3 (TCLKF).



<b>Parallel Port H Alternate High Register (PHAHR) (Address = 0x0033)</b>		
<b>Bit(s)</b>	<b>Value</b>	<b>Description</b>
7:6	00	This value is reserved and must not be used.
	01	Parallel Port H bit 7 alternate output 1 (I7).
	10	Parallel Port H bit 7 alternate output 2 (PWM3).
	11	Parallel Port H bit 7 alternate output 3 (SCLKC).
5:4	00	This value is reserved and must not be used.
	01	Parallel Port H bit 6 alternate output 1 (I6).
	10	Parallel Port H bit 6 alternate output 2 (PWM2).
	11	Parallel Port H bit 6 alternate output 3 (TXE).
3:2	00	This value is reserved and must not be used.
	01	Parallel Port H bit 5 alternate output 1 (I5).
	10	Parallel Port H bit 5 alternate output 2 (PWM1).
	11	Parallel Port H bit 5 alternate output 3 (RCLKE).
1:0	00	This value is reserved and must not be used.
	01	Parallel Port H bit 4 alternate output 1 (I4).
	10	Parallel Port H bit 4 alternate output 2 (PWM0).
	11	Parallel Port H bit 4 alternate output 3 (TCLKE).

<b>Parallel Port H Function Register (PHFR) (Address = 0x0035)</b>		
<b>Bit(s)</b>	<b>Value</b>	<b>Description</b>
7:0	0	The corresponding port bit functions normally.
	1	The corresponding port bit carries its alternate signal as an output. See Table 13-1.

<b>Parallel Port H Drive Control Register (PHDCR) (Address = 0x0036)</b>		
<b>Bit(s)</b>	<b>Value</b>	<b>Description</b>
7:0	0	The corresponding port bit, as an output, is driven high and low.
	1	The corresponding port bit, as an output, is open-drain.

<b>Parallel Port H Data Direction Register (PHDDR) (Address = 0x0037)</b>		
<b>Bit(s)</b>	<b>Value</b>	<b>Description</b>
7:0	0	The corresponding port bit is an input.
	1	The corresponding port bit is an output.

<b>Memory Alternate Control Register (MACR) (Address = 0x001D)</b>		
<b>Bit(s)</b>	<b>Value</b>	<b>Description</b>
7	0	Normal 8-bit operation for /CS3. Use MBxCR for wait states. This bit is used only when external memory is present.
	1	Normal 16-bit operation for /CS3. Use MBxCR for wait states. When stand-alone operation is selected (by strapping a pin), this bit is forced high.
6		This bit is reserved and must not be used.
5:4	00	Normal 8-bit operation for /CS2.
	01	Page-Mode 8-bit operation for /CS2.
	10	Normal 16-bit operation for /CS2.
	11	Page-Mode 16-bit operation for /CS2.
3:2	00	Normal 8-bit operation for /CS1.
	01	Page-Mode 8-bit operation for /CS1.
	10	Normal 16-bit operation for /CS1.
	11	Page-Mode 16-bit operation for /CS1.
1:0	00	Normal 8-bit operation for /CS0.
	01	Page-Mode 8-bit operation for /CS0.
	10	Normal 16-bit operation for /CS0.
	11	Page-Mode 16-bit operation for /CS0.

# 14. TIMER A

## 14.1 Overview

The Timer A peripheral consists of ten separate eight-bit countdown timers, A1–A10. Each counter counts down from a programmed time constant, which is automatically reloaded into the respective counter when the count reaches zero. For example, if the reload register contains 127, then 128 pulses enter on the left before a pulse exits on the right (see Figure 14-1). If the reload register contains zero, then each pulse on the left results in a pulse on the right, that is, there is division by one. The reload register can contain any number in the range from 0 to 255. The counter divides by  $(n + 1)$ .

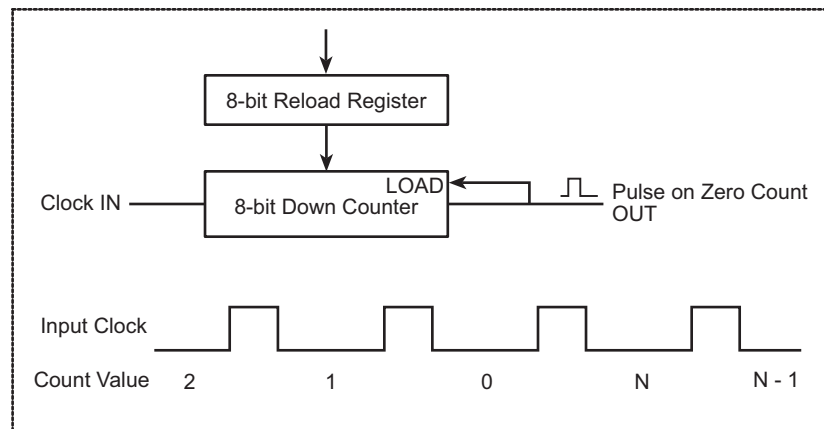

**Figure 14-1. Reload Register Operation**

The output pulses are always one clock wide. Clocking of the timers takes place on the negative edge of these pulses. When the counter reaches zero, the reload register is loaded into the counter on the next input pulse instead of a count being performed. The terminal count condition for Timers A1–A7 is reported in a status register and can be programmed to generate an interrupt. Six of these seven timers (A2–A7) have the option of being cascaded from Timer A1, but the primary clock for all of the timers is the peripheral clock either directly or divided by 2 (the default).

Timers A2–A7 can be used to generate baud rates for Serial Ports A–F, or they can be used as general-purpose timers if the dedicated timers on the Rabbit 5000 serial ports are used. The three remaining timers (A8–A10) serve as prescalers for the input capture, PWM, and quadrature decoder peripherals respectively. The peripherals clocked by these timers can

generate interrupts but the timers themselves cannot. Furthermore, these timers cannot be cascaded with Timer A1.

The individual Timer A capabilities are summarized in the table below. There is a bit in the control/status register to disable all ten timers globally.

Timer	Cascade from A1	Interrupt	Associated Peripheral
A1	No	Yes	Parallel Ports D–E, Timers B–C
A2	Yes	Yes	Serial Port E
A3	Yes	Yes	Serial Port F
A4	Yes	Yes	Serial Port A
A5	Yes	Yes	Serial Port B
A6	Yes	Yes	Serial Port C
A7	Yes	Yes	Serial Port D
A8	No	No	Input Capture
A9	No	No	Pulse-Width Modulator
A10	No	No	Quadrature Decoder

There is one interrupt vector for Timer A and a common interrupt priority. A common status register (TACSR) has bits for Timers A1–A7 that indicate if the output pulse for that timer has taken place since the last read of the status register. These bits are cleared when the status register is read. No bit will be lost. Either it will be read by the status register read or it will be set after the status register read is complete. If a bit is on and the corresponding interrupt is enabled, an interrupt will occur when priorities allow. However, a separate interrupt is not guaranteed for each bit with an enabled interrupt. If the bit is read in the status register, it is cleared and no further interrupt corresponding to that bit will be requested. It is possible that one bit will cause an interrupt, and then one or more additional bits will be set before the status register is read. After these bits are cleared, they cannot cause an interrupt. The proper rule to follow is for the interrupt routine to handle all bits that it sees set.

### 14.1.1 Block Diagram

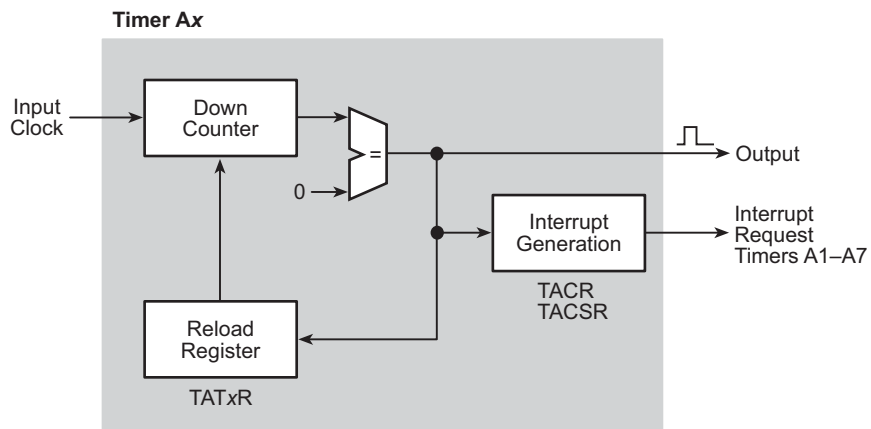
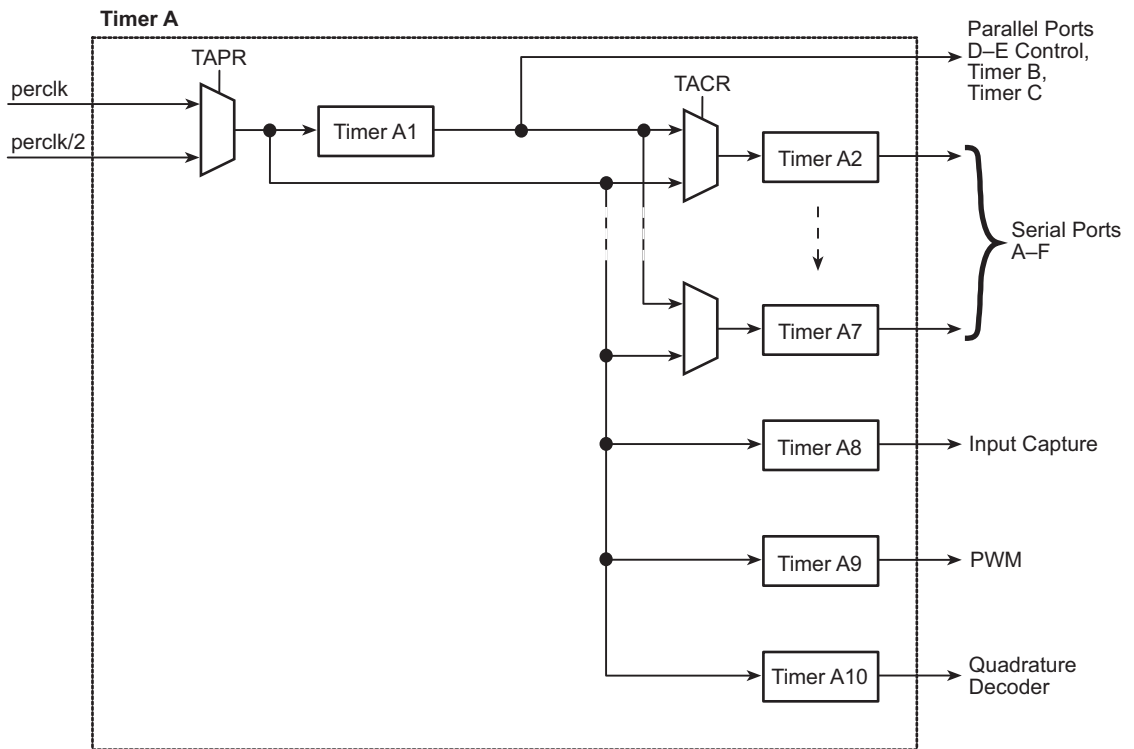

## 14.1.2 Registers

Register Name	Mnemonic	I/O Address	R/W	Reset
Timer A Control/Status Register	TACSR	0x00A0	R/W	00000000
Timer A Prescale Register	TAPR	0x00A1	R/W	xxxxxxx1
Timer A Time Constant 1 Register	TAT1R	0x00A3	R/W	xxxxxxx
Timer A Control Register	TACR	0x00A4	R/W	00000000
Timer A Time Constant 2 Register	TAT2R	0x00A5	R/W	xxxxxxx
Timer A Time Constant 8 Register	TAT8R	0x00A6	R/W	xxxxxxx
Timer A Time Constant 3 Register	TAT3R	0x00A7	R/W	xxxxxxx
Timer A Time Constant 9 Register	TAT9R	0x00A8	R/W	xxxxxxx
Timer A Time Constant 4 Register	TAT4R	0x00A9	R/W	xxxxxxx
Timer A Time Constant 10 Register	TAT10R	0x00AA	R/W	xxxxxxx
Timer A Time Constant 5 Register	TAT5R	0x00AB	R/W	xxxxxxx
Timer A Time Constant 6 Register	TAT6R	0x00AD	R/W	xxxxxxx
Timer A Time Constant 7 Register	TAT7R	0x00AF	R/W	xxxxxxx

## 14.2 Dependencies

### 14.2.1 I/O Pins

The Timer A outputs do not come out directly on any of the I/O pins. They can be used to control when the output occurs on Parallel Ports D–E, and can affect the output times of Serial Ports A–F and the PWM.

### 14.2.2 Clocks

The timers in Timer A can be clocked by either `perclk` or `perclk/2`, as selected in `TAPR`. In addition, Timers A2–A7 can be clocked by the output of Timer A1 by selecting that option in `TACSR`.

### 14.2.3 Other Registers

Register	Function
GCSR	Select peripheral clock mode.

## 14.2.4 Interrupts

A Timer A interrupt can be generated whenever Timers A1–A7 decrement to zero by enabling the appropriate bit in TACSR. The interrupt request is cleared when TACSR is read.

The Timer A interrupt vector is in the IIR at offset 0x0A0. It can be set as priority 1, 2, or 3 in TACR.

## 14.3 Operation

The following steps explain how to set up a Timer A timer.

1. Use the default  $\text{perclk}/2$  in TAPR as the Timer A input clock. You may instead select  $\text{perclk}$  in TAPR.
2. Select the source clocks for Timers A2–A7 in TACR.
3. Write the desired divider value to TATxR for all timers that will be used.
4. Enable Timer A by writing a 1 to bit 0 of TACSR.

### 14.3.1 Handling Interrupts

The following steps explain how an interrupt is set up and used.

1. Write the vector to the interrupt service routine to the internal interrupt table.
2. Configure TACSR to select which timers will generate an interrupt.
3. Configure TACR to select the interrupt priority (note that interrupts will be enabled once this value is set). This should be done last.

The interrupt request is cleared by reading from TACSR.

### 14.3.2 Example ISR

A sample interrupt handler is shown below.

```
timerA_isr::
    push af                ; save used registers
    ioi ld a, (TACSR)     ; clear the interrupt request and get status

    ; handle all interrupts flagged in TACSR here

    pop af                ; restore registers
    ipres
    ret
```

## 14.4 Register Descriptions

Timer A Control/Status Register (TACSR) (Address = 0x00A0)		
Bit(s)	Value	Description
7:1 (Read-only)	0	The corresponding Timer A counter has not reached its terminal count.
	1	The corresponding Timer A counter has reached its terminal count. These status bits (not the interrupt enable bits) are cleared by the read of this register, as is the Timer A interrupt.
7:1 (Write-only)	0	The corresponding Timer A interrupt is disabled.
	1	The corresponding Timer A interrupt is enabled.
0	0	The clock for Timer A (perclk or perclk/2) is disabled.
	1	The clock for Timer A (perclk or perclk/2) is enabled.

Timer A Prescale Register (TAPR) (Address = 0x00A1)		
Bit(s)	Value	Description
7:1		These bits are reserved and should be written with zero.
0	0	The main clock for Timer A is the peripheral clock (perclk).
	1	The main clock for Timer A is the peripheral clock divided by two (perclk/2).



<b>Timer A Control Register (TACR) (Address = 0x00A4)</b>		
<b>Bit(s)</b>	<b>Value</b>	<b>Description</b>
7	0	Timer A7 clocked by the main Timer A clock.
	1	Timer A7 clocked by the output of Timer A1.
6	0	Timer A6 clocked by the main Timer A clock.
	1	Timer A6 clocked by the output of Timer A1.
5	0	Timer A5 clocked by the main Timer A clock.
	1	Timer A5 clocked by the output of Timer A1.
4	0	Timer A4 clocked by the main Timer A clock.
	1	Timer A4 clocked by the output of Timer A1.
3	0	Timer A3 clocked by the main Timer A clock.
	1	Timer A3 clocked by the output of Timer A1.
2	0	Timer A2 clocked by the main Timer A clock.
	1	Timer A2 clocked by the output of Timer A1.
1:0	00	Timer A interrupts are disabled.
	01	Timer A interrupt use Interrupt Priority 1.
	10	Timer A interrupt use Interrupt Priority 2.
	11	Timer A interrupt use Interrupt Priority 3.

<b>Timer A Time Constant x Register (TAT1R) (Address = 0x00A3)</b>		
<b>(TAT2R) (Address = 0x00A5)</b>		
<b>(TAT3R) (Address = 0x00A7)</b>		
<b>(TAT4R) (Address = 0x00A9)</b>		
<b>(TAT5R) (Address = 0x00AB)</b>		
<b>(TAT6R) (Address = 0x00AD)</b>		
<b>(TAT7R) (Address = 0x00AF)</b>		
<b>(TAT8R) (Address = 0x00A6)</b>		
<b>(TAT9R) (Address = 0x00A8)</b>		
<b>(TAT10R) (Address = 0x00AA)</b>		
<b>Bit(s)</b>	<b>Value</b>	<b>Description</b>
7:0		Time constant for the Timer A counter. This time constant will take effect the next time that the Timer A counter counts down to zero. The timer counts modulo $n + 1$ , where $n$ is the programmed time constant.

<b>Global Control/Status Register (GCSR) (Address = 0x0000)</b>		
<b>Bit(s)</b>	<b>Value</b>	<b>Description</b>
4:2	000	Processor clock from the main clock, divided by eight. Peripheral clock from the main clock, divided by eight.
	001	Processor clock from the main clock, divided by eight. Peripheral clock from the main clock.
	010	Processor clock from the main clock. Peripheral clock from the main clock.
	011	Processor clock from the main clock, divided by two. Peripheral clock from the main clock, divided by two.
	100	Processor clock from the 32 kHz clock, optionally divided via GPSCR. Peripheral clock from the 32 kHz clock, optionally divided via GPSCR.
	101	Processor clock from the 32 kHz clock, optionally divided via GPSCR. Peripheral clock from the 32 kHz clock, optionally divided via GPSCR. The fast clock is disabled.
	110	Processor clock from the main clock, divided by four. Peripheral clock from the main clock, divided by four.
	111	Processor clock from the main clock, divided by six. Peripheral clock from the main clock, divided by six.

# 15. TIMER B

## 15.1 Overview

The Timer B peripheral consists of a ten-bit free running up-counter, two match registers, and two step registers. Timer B is driven by  $\text{perclk}/2$ , by  $\text{perclk}/16$ , or by the output of Timer A1. Timer B generates an output pulse whenever the counter reaches the match value. This output pulse can generate an interrupt and will set a status bit in the status register. The processor may then write a new value to the match register. This allows Timer B to be used for pulse-width or pulse-position modulation because the outputs of Timer B can clock the outputs on Parallel Ports D and E.

The compare value comes from either the match register or the value internally generated via the step register. When using the match register, a new match value must be written to the match register after each match condition, LSB first. When using the step register, the hardware automatically calculates the next match value by adding the contents of the step register to the current match value. This allows Timer B matches to be generated at regular periods without calculating the new match value during the interrupt service routine.

### 15.1.1 Block Diagram

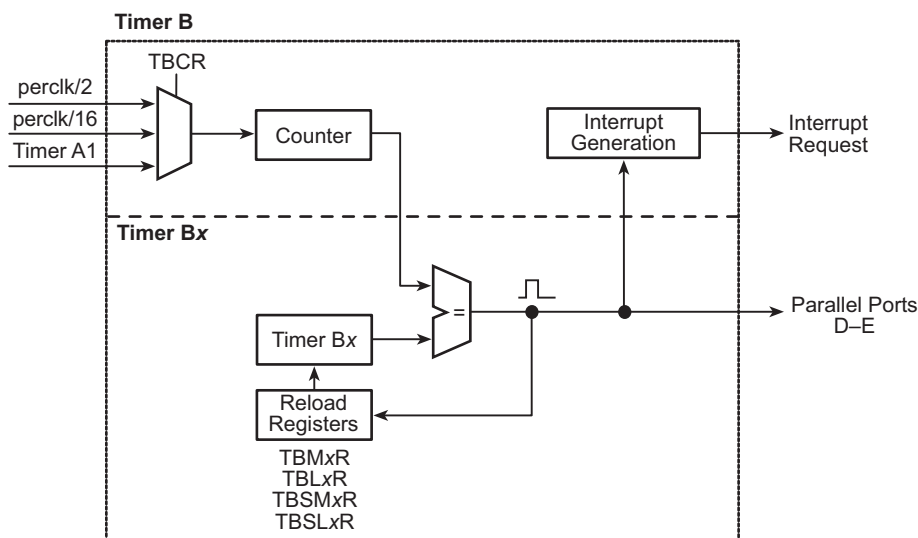

## 15.1.2 Registers

Register Name	Mnemonic	I/O Address	R/W	Reset
Timer B Control/Status Register	TBCSR	0x00B0	R/W	xxxx0000
Timer B Control Register	TBCR	0x00B1	R/W	xx000000
Timer B MSB 1 Register	TBM1R	0x00B2	R/W	xxxxxxx
Timer B LSB 1 Register	TBL1R	0x00B3	R/W	xxxxxxx
Timer B MSB 2 Register	TBM2R	0x00B4	R/W	xxxxxxx
Timer B LSB 2 Register	TBL2R	0x00B5	R/W	xxxxxxx
Timer B Step LSB 1 Register	TBSL1R	0x00BA	R/W	xxxxxxx
Timer B Step MSB 1 Register	TBSM1R	0x00BB	R/W	xxxxxxx
Timer B Step LSB 2 Register	TBSL2R	0x00BC	R/W	xxxxxxx
Timer B Step MSB 2 Register	TBSM2R	0x00BD	R/W	xxxxxxx
Timer B Count MSB Register	TBCMR	0x00BE	R	xxxxxxx
Timer B Count LSB Register	TBCLR	0x00BF	R	xxxxxxx

## 15.2 Dependencies

### 15.2.1 I/O Pins

The output of Timer B does not come out directly on any of the I/O pins. It can be used to control when the output occurs on Parallel Ports D–E.

### 15.2.2 Clocks

The timer in Timer B can be clocked by  $\text{perclk}/2$ ,  $\text{perclk}/16$ , or by countdown Timer A1 as selected in TBCR.

### 15.2.3 Other Registers

Register	Function
GCSR	Select peripheral clock mode.

### 15.2.4 Interrupts

A Timer B interrupt can be generated whenever the counter equals one of the match registers by enabling the appropriate bit in TBCSR. The interrupt request is cleared when TBCSR is read.

## 15.3 Operation

The following steps explain how to set up a Timer B countdown timer.

1. Select  $\text{perclk}/2$ ,  $\text{perclk}/16$ , or countdown Timer A1 in TBCR.
2. Use TBCR to select whether countdown Timers B1–B2 operate normally with the match registers or whether they use the step registers to calculate match values.
3. Enable Timer B by writing a 1 to bit 0 of TBCSR.

### 15.3.1 Handling Interrupts

The following steps explain how an interrupt is set up and used.

1. Write the vector to the interrupt service routine to the internal interrupt table.
2. Configure TBCSR to select which match register will generate an interrupt.
3. Configure TBCR to select the interrupt priority (note that interrupts will be enabled once this value is set; this step should be done last).

The interrupt request is cleared by reading from TBCSR.

### 15.3.2 Example ISR

A sample interrupt handler is shown below.

```
timerB_isr::
    push af                ; save used registers
    ioi ld a, (TBCSR)     ; clear the interrupt request and get status

    ; handle all interrupts flagged in TBCSR here
    ; reload match register(s) if necessary

    pop af                ; restore used registers
    ipres
    ret
```

## 15.4 Register Descriptions

Timer B Control/Status Register (TBCSR) (Address = 0x00B0)		
Bit(s)	Value	Description
7:3		These bits always read as zero.
2:1 (Read-only)	0	The corresponding Timer B comparator has not encountered a match condition.
	1	The corresponding Timer B comparator has encountered a match condition. These status bits (but not the interrupt enable bits) are cleared by the read of this register, as is the Timer B interrupt.
2:1 (Write-only)	0	The corresponding Timer B interrupt is disabled.
	1	The corresponding Timer B interrupt is enabled.
0	0	The clock for Timer B (perclk/2) is disabled.
	1	The clock for Timer B (perclk/2) is enabled.

Timer B Control Register (TBCR) (Address = 0x00B1)		
Bit(s)	Value	Description
7:6		These bits are reserved and should be written with zero.
5	0	Normal Timer B2 operation using the match registers.
	1	Enable Timer B2 to use the step registers to calculate match values.
4	0	Normal Timer B1 operation, using the match registers.
	1	Enable Timer B1 to use the step registers to calculate match values.
3:2	00	Timer B clocked by perclk/2.
	01	Timer B clocked by the output of Timer A1.
	10	Timer B clocked by Timer B clock divided by 8 (perclk/16).
	11	Timer B clocked by Timer B clock divided by 8 (perclk/16).
1:0	00	Timer B interrupts are disabled.
	01	Timer B interrupt use Interrupt Priority 1.
	10	Timer B interrupt use Interrupt Priority 2.
	11	Timer B interrupt use Interrupt Priority 3.

<b>Timer B Count MSB x Register</b>			<b>(TBM1R)</b>	<b>(Address = 0x00B2)</b>
			<b>(TBM2R)</b>	<b>(Address = 0x00B4)</b>
<b>Bit(s)</b>	<b>Value</b>	<b>Description</b>		
7:6		Two MSBs of the compare value for the Timer B comparator. This compare value will be loaded into the actual comparator when the current compare detects a match.		
5:0		These bits are reserved and should be written with zero.		

<b>Timer B Count LSB x Register</b>			<b>(TBL1R)</b>	<b>(Address = 0x00B3)</b>
			<b>(TBL2R)</b>	<b>(Address = 0x00B5)</b>
<b>Bit(s)</b>	<b>Value</b>	<b>Description</b>		
7:0		Eight LSBs of the compare value for the Timer B comparator. This compare value will be loaded into the actual comparator when the current compare detects a match.		

<b>Timer B Step LSB x Register</b>			<b>(TBSL1R)</b>	<b>(Address = 0x00BA)</b>
			<b>(TBSL2R)</b>	<b>(Address = 0x00BC)</b>
<b>Bit(s)</b>	<b>Value</b>	<b>Description</b>		
7:0		Eight LSBs of the step size for the Timer B comparator. The new compare value will be loaded into the actual comparator when the current compare detects a match.		

<b>Timer B Step MSB x Register</b>			<b>(TBSM1R)</b>	<b>(Address = 0x00BB)</b>
			<b>(TBSM2R)</b>	<b>(Address = 0x00BD)</b>
<b>Bit(s)</b>	<b>Value</b>	<b>Description</b>		
7:2		These bits are ignored but should be written with zeros.		
1:0		Two MSBs of the step size for the Timer B comparator. The new compare value will be loaded into the actual comparator when the current compare detects a match.		

<b>Timer B Count MSB Register</b>			<b>(TBCMR)</b>	<b>(Address = 0x00BE)</b>
<b>Bit(s)</b>	<b>Value</b>	<b>Description</b>		
7:6	Read	The current value of the two MSBs of the Timer B counter is reported.		
5:0		These bits are always read as zeros.		

<b>Timer B Count LSB Register (TBCLR) (Address = 0x00BF)</b>		
<b>Bit(s)</b>	<b>Value</b>	<b>Description</b>
7:0	Read	The current value of the eight LSBs of the Timer B counter is reported.

<b>Global Control/Status Register (GCSR) (Address = 0x0000)</b>		
<b>Bit(s)</b>	<b>Value</b>	<b>Description</b>
4:2	000	Processor clock from the main clock, divided by eight. Peripheral clock from the main clock, divided by eight.
	001	Processor clock from the main clock, divided by eight. Peripheral clock from the main clock.
	010	Processor clock from the main clock. Peripheral clock from the main clock.
	011	Processor clock from the main clock, divided by two. Peripheral clock from the main clock, divided by two.
	100	Processor clock from the 32 kHz clock, optionally divided via GPSCR. Peripheral clock from the 32 kHz clock, optionally divided via GPSCR.
	101	Processor clock from the 32 kHz clock, optionally divided via GPSCR. Peripheral clock from the 32 kHz clock, optionally divided via GPSCR. The fast clock is disabled.
	110	Processor clock from the main clock, divided by four. Peripheral clock from the main clock, divided by four.
	111	Processor clock from the main clock, divided by six. Peripheral clock from the main clock, divided by six.



# 16. TIMER C

## 16.1 Overview

The Timer C peripheral is a 16-bit up-counter clocked by the peripheral clock divided by 2, by the peripheral clock divided by 16, or by the output of countdown Timer A1. The counter counts from zero to the limit programmed into the Timer C divider registers and then restarts at zero, so the overall cycle count is the value in the divider registers plus one. There are four Timer C outputs that are called Timers C0–C3. Each output is controlled by a 16-bit set value and a 16-bit reset value. Each output is set to one when the count matches the value in the corresponding set register and is cleared when the count matches the value programmed in the corresponding reset register. This allows the creation of quadrature signals or three-phase signals with a variable frequency for motor-control applications. The values in all of the Timer C registers are transferred to holding registers for use during the count cycle when the counter is reloaded with zeros, allowing the control registers to be reloaded at any time during the count cycle.

Timer C can generate an interrupt when the count limit value is reached.

A separate Timer C Block Access Register (TCBAR) and Timer C Block Pointer Register (TCBPR) are available to allow DMA control of Timer C. The pointer register contains the address of the Timer C register to be accessed via the access register. Each read or write of the access register automatically increments the pointer register through the sequence shown below. Note that only the lower five bits of the pointer actually change. This allows the DMA to write to a fixed internal I/O location but still program all of the relevant Timer registers. The pointer register can be written and read if necessary. Normally the pointer register is initialized to 0x02 (the Timer C Divider Low Register), and the DMA then transfers blocks of 18 bytes to completely reprogram Timer C.

```
0x502 -> 0x503 -> 0x508 -> 0x509 -> 0x50A -> 0x50B ->  
0x50C -> 0x50D -> 0x50E -> 0x50F -> 0x518 -> 0x519 ->  
0x51A -> 0x51B -> 0x51C -> 0x51D -> 0x51E -> 0x51F ->
```

When the DMA destination address is the TCBAR, the DMA request from Timer C is connected automatically to the DMA.

## 16.1.1 Block Diagram

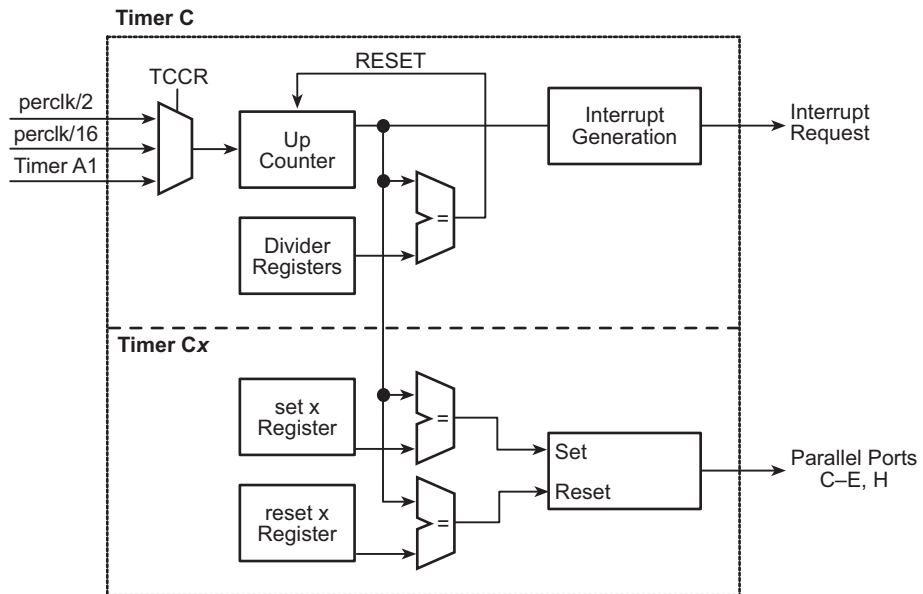

## 16.1.2 Registers

Register Name	Mnemonic	I/O Address	R/W	Reset
Timer C Control/Status Register	TCCSR	0x0500	R/W	xxxx0000
Timer C Control Register	TCCR	0x0501	R/W	xx000000
Timer C Divider Low Register	TCDLR	0x0502	R/W	00000000
Timer C Divider High Register	TCDHR	0x0503	R/W	00000000
Timer C Set 0 Low Register	TCS0LR	0x0508	R/W	xxxxxxxx
Timer C Set 0 High Register	TCS0HR	0x0509	R/W	xxxxxxxx
Timer C Reset 0 Low Register	TCR0LR	0x050A	R/W	xxxxxxxx
Timer C Reset 0 High Register	TCR0HR	0x050B	R/W	xxxxxxxx
Timer C Set 1 Low Register	TCS1LR	0x050C	R/W	xxxxxxxx
Timer C Set 1 High Register	TCS1HR	0x050D	R/W	xxxxxxxx
Timer C Reset 1 Low Register	TCR1LR	0x050E	R/W	xxxxxxxx
Timer C Reset 1 High Register	TCR1HR	0x050F	R/W	xxxxxxxx
Timer C Set 2 Low Register	TCS2LR	0x0518	R/W	xxxxxxxx
Timer C Set 2 High Register	TCS2HR	0x0519	R/W	xxxxxxxx
Timer C Reset 2 Low Register	TCR2LR	0x051A	R/W	xxxxxxxx
Timer C Reset 2 High Register	TCR2HR	0x051B	R/W	xxxxxxxx
Timer C Set 3 Low Register	TCS3LR	0x051C	R/W	xxxxxxxx
Timer C Set 3 High Register	TCS3HR	0x051D	R/W	xxxxxxxx
Timer C Reset 3 Low Register	TCR3LR	0x051E	R/W	xxxxxxxx
Timer C Reset 3 High Register	TCR3HR	0x051F	R/W	xxxxxxxx
Timer C Block Access Register	TCBAR	0x00F8	W	xxxxxxxx
Timer C Block Pointer Register	TCBPR	0x00F9	W	00000010

## 16.2 Dependencies

### 16.2.1 I/O Pins

The four Timer C outputs can be directed to PC0-PC3, PD0-PD3, PE0-PE3, or PH0-PH3.

### 16.2.2 Clocks

The timer in Timer C is a 16-bit up-counter clocked by the peripheral clock divided by 2, by the peripheral clock divided by 16, or by the output of Timer A1 as selected in TCCR.

### 16.2.3 Other Registers

Register	Function
GCSR	Select peripheral clock mode.
PCFR, PCALR PDFR, PDALR PEFR, PEALR PHFR, PHALR	Alternate port output selection

### 16.2.4 Interrupts

A Timer C interrupt is enabled in TCCR, and will occur whenever the count limit value is reached. The interrupt request is cleared when TCCSR is read.

## 16.3 Operation

The following steps explain how to set up a Timer C timer.

1. Select  $\text{perclk}/2$ ,  $\text{perclk}/16$ , or countdown Timer A1 in TCCR.
2. Load the desired upper limit for the counter into TCDLR and TCDHR. The overall clock count per Timer C cycle will be the value loaded into the divider registers plus one.
3. Load the desired set and reset values for the Timer C outputs into the set and reset registers (TCSxLR, TCSxHR, TCRxLR, and TCRxHR).
4. If you intend to use DMA control of Timer C, use TCBAR to access the Timer C register pointed to by TCBPR.
5. Enable the desired output pins for Timer C by writing to the appropriate parallel port function and alternate output registers.
6. Enable Timer C by writing a 1 to bit 0 of TCCSR.

### 16.3.1 Handling Interrupts

The following steps explain how an interrupt is used.

1. Write the vector to the interrupt service routine to the internal interrupt table.
2. Configure TCCR to select the interrupt priority (note that interrupts will be enabled once this value is set).

The interrupt request is cleared by reading from TCCSR.

### 16.3.2 Example ISR

A sample interrupt handler is shown below.

```
timerC_isr::
    push af                ; save used registers
    ioi ld a, (TCCSR)     ; clear the interrupt request and get status

    ; handle all interrupts flagged in TCCSR here

    pop af                 ; restore used registers
    ipres
    ret
```

## 16.4 Register Descriptions

Timer C Control/Status Register		(TCCSR)	(Address = 0x0500)
Bit(s)	Value	Description	
7:2		These bits are always read as zero.	
1 (Read-only)	0	Timer C divider has not reached its maximum value.	
	1	Timer C divider has reached its maximum value. This status bit is cleared by the read of this register, as is the Timer C interrupt.	
0	0	The clock for Timer C (perclk/2) is disabled.	
	1	The clock for Timer C (perclk/2) is enabled.	

Timer C Control Register		(TCCR)	(Address = 0x0501)
Bit(s)	Value	Description	
7:4		These bits are reserved and should be written with zero.	
3:2	00	Timer C clocked by the peripheral clock divided by 2.	
	01	Timer C clocked by the output of Timer A1.	
	10	Timer C clocked by the peripheral clock divided by 16.	
	11	Timer C clocked by the peripheral clock divided by 16.	
1:0	00	Timer C interrupts are disabled.	
	01	Timer C interrupt uses Interrupt Priority 1.	
	10	Timer C interrupt uses Interrupt Priority 2.	
	11	Timer C interrupt uses Interrupt Priority 3.	

Timer C Divider Low Register		(TCDLR)	(Address = 0x0502)
Bit(s)	Value	Description	
7:0		The eight LSBs of the divider limit value for Timer C are stored.	

Timer C Divider High Register		(TCDHR)	(Address = 0x0503)
Bit(s)	Value	Description	
7:0		The eight MSBs of the divider limit value for Timer C are stored.	

Timer C Set x Low Register		
		(TCS0LR) (Address = 0x0508)
		(TCS1LR) (Address = 0x050C)
		(TCS2LR) (Address = 0x0518)
		(TCS3LR) (Address = 0x051C)
Bit(s)	Value	Description
7:0		Eight LSBs of the match value to set Timer C Output x.

Timer C Set x High Register		
		(TCS0HR) (Address = 0x0509)
		(TCS1HR) (Address = 0x050D)
		(TCS2HR) (Address = 0x0519)
		(TCS3HR) (Address = 0x051D)
Bit(s)	Value	Description
7:0		Eight MSBs of the match value to set Timer C Output x.

Timer C Reset x Low Register		
		(TCR0LR) (Address = 0x050A)
		(TCR1LR) (Address = 0x050E)
		(TCR2LR) (Address = 0x051A)
		(TCR3LR) (Address = 0x051E)
Bit(s)	Value	Description
7:0		Eight LSBs of the match value to reset Timer C Output x.

Timer C Reset x High Register		
		(TCR0HR) (Address = 0x050B)
		(TCR1HR) (Address = 0x050F)
		(TCR2HR) (Address = 0x051B)
		(TCR3HR) (Address = 0x051F)
Bit(s)	Value	Description
7:0		Eight MSBs of the match value to reset Timer C Output x.

Timer C Block Access Register		
		(TCBAR) (Address = 0x00F8)
Bit(s)	Value	Description
7:0		Access the Timer C register pointed to by TCBPR. TCBPR is automatically updated to the next Timer C register address in the sequence.

<b>Timer C Block Pointer Register (TCBPR) (Address = 0x00F9)</b>		
<b>Bit(s)</b>	<b>Value</b>	<b>Description</b>
7:5		These bits always read as 0x0.
4:0		Five least significant bits of the Timer C register address for indirect access.

<b>Global Control/Status Register (GCSR) (Address = 0x0000)</b>		
<b>Bit(s)</b>	<b>Value</b>	<b>Description</b>
4:2	000	Processor clock from the main clock, divided by eight. Peripheral clock from the main clock, divided by eight.
	001	Processor clock from the main clock, divided by eight. Peripheral clock from the main clock.
	010	Processor clock from the main clock. Peripheral clock from the main clock.
	011	Processor clock from the main clock, divided by two. Peripheral clock from the main clock, divided by two.
	100	Processor clock from the 32 kHz clock, optionally divided via GPSCR. Peripheral clock from the 32 kHz clock, optionally divided via GPSCR.
	101	Processor clock from the 32 kHz clock, optionally divided via GPSCR. Peripheral clock from the 32 kHz clock, optionally divided via GPSCR. The fast clock is disabled.
	110	Processor clock from the main clock, divided by four. Peripheral clock from the main clock, divided by four.
	111	Processor clock from the main clock, divided by six. Peripheral clock from the main clock, divided by six.



# 17. SERIAL PORTS A – D

## 17.1 Overview

Serial Ports A, B, C, and D are identical, except for the source of the data clock and the transmit, receive, and clock pins. In addition to being used as a regular serial port, Serial Port A can be used to bootstrap the processor. Each serial port can be used in the asynchronous or the clocked serial mode with an internal or external clock.

In the asynchronous mode, either 7 or 8 data bits can be transferred, and a parity bit and/or a ninth data bit can be appended as well. Parity and the ninth data bits are also detected when they are received. The asynchronous mode is full-duplex, while the clocked mode can be half or full-duplex.

Both transmit and receive have one byte of buffering — a byte may be read while another byte is being received, or the next byte to be transmitted can be loaded while the current byte is still being transferred out.

The status of each serial port is available in its Serial Port Status Register (SxSR), and contains information on whether a received byte is available, the receive buffer was overrun, a parity error was received, the transmit buffer is empty or busy sending a byte, and the state of the ninth data bit (whether it is an address bit or a stop bit). Each serial port has a separate interrupt vector that will be requested whenever the transmit buffer is emptied or the receive buffer contains a full byte.

All four common SPI clock modes are supported, and the bit order of the data may be either MSB or LSB first. The transmit and receive operations are under program control as well.

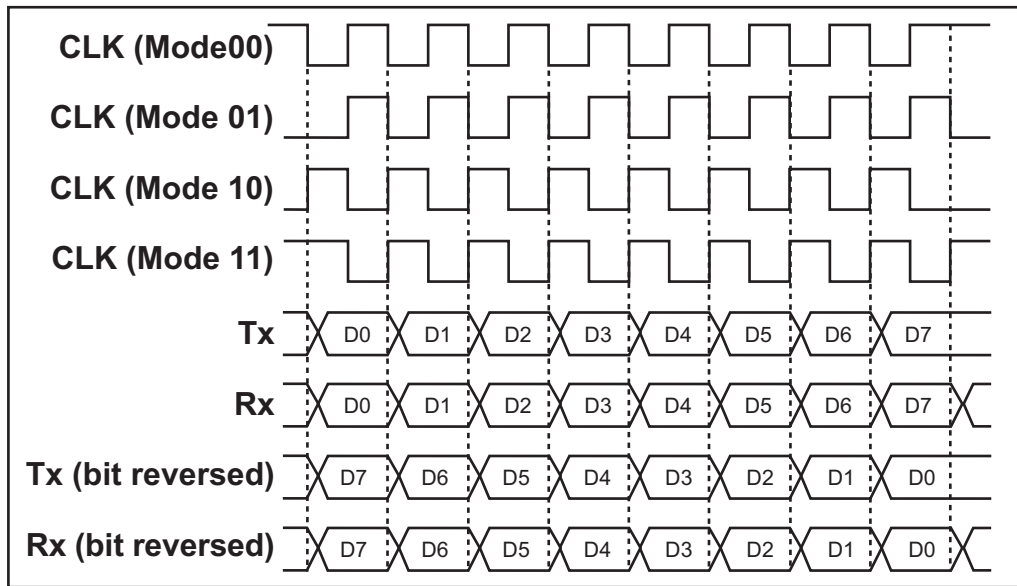

**Figure 17-1. Serial Ports A – D Operation in Clocked Serial Mode**

In the asynchronous mode, IrDA-compliant RZI encoding can be enabled to reduce the bit widths to 3/16 the normal width (1/8 the normal width if the serial data clock is 8× instead of 16×), which allows the serial port signal to be connected directly to an IrDA transceiver.

It is possible to select the same pin on Parallel Port C for both transmit and receive operation. This allows glueless support for bidirectional serial protocols.

It is possible to synchronize a clocked serial transfer to the match registers of Timer B to generate precisely timed transmissions.

**Table 17-1. Timer A Data Clocks**

Serial Port	Data Clock
A	Timer A4
B	Timer A5
C	Timer A6
D	Timer A7

The serial port data clocks can be generated from the appropriate 8-bit timer from Timer A shown in Table 17-1 or from a dedicated n+1 15-bit divider. In either case, the resulting byte data rate in the asynchronous mode is 1/8 or 1/16 the data clock rate (selectable). However, the byte data rate in the clocked serial mode is equal to the data clock rate as generated from the appropriate Timer A timer or from the dedicated 15-bit divider.

When Serial Port A is used in the asynchronous bootstrap mode, the 32 kHz clock is used to generate the expected 2400 bps data rate. An external clock must be supplied for the clocked serial bootstrap mode.

The behavior of the serial port during a break (line held low) is configurable; character assembly can continue during the break condition to allow for timing the break, or character assembly can be inhibited to reduce the interrupt overhead.

### 17.1.1 Block Diagram

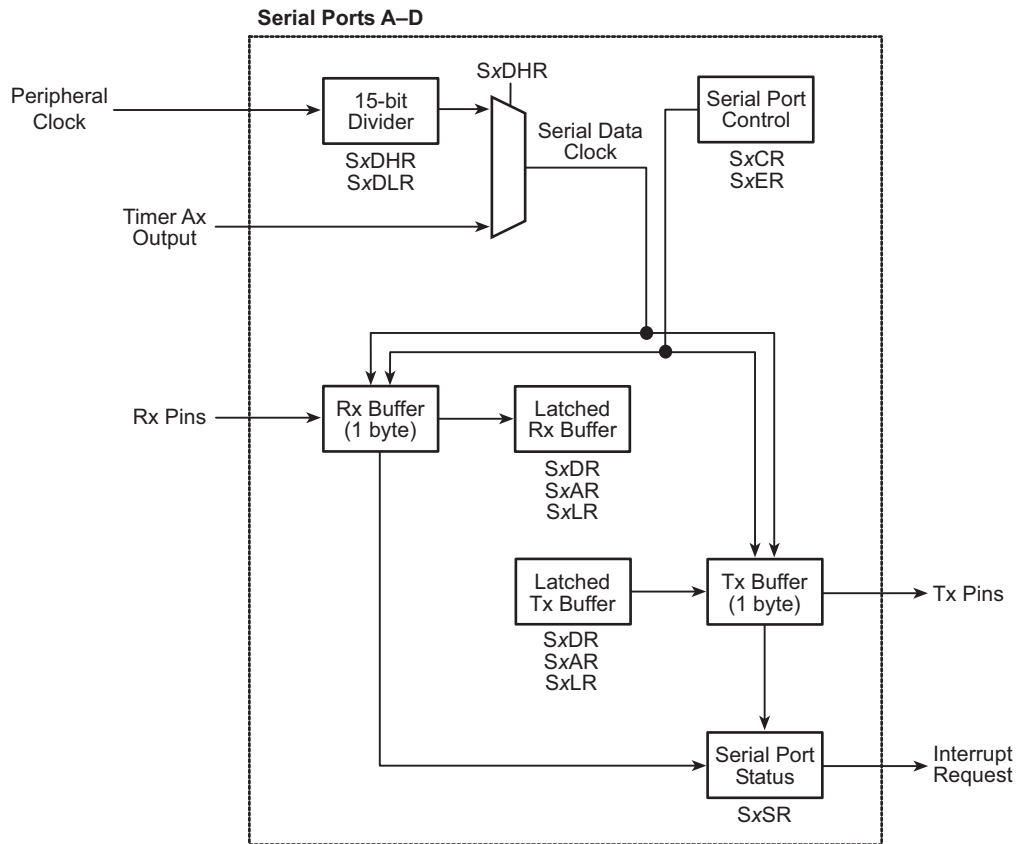

## 17.1.2 Registers

Register Name	Mnemonic	I/O Address	R/W	Reset
Serial Port A Data Register	SADR	0x00C0	R/W	xxxxxxx
Serial Port A Address Register	SAAR	0x00C1	W	xxxxxxx
Serial Port A Long Stop Register	SALR	0x00C2	W	xxxxxxx
Serial Port A Status Register	SASR	0x00C3	R	0xx00000
Serial Port A Control Register	SACR	0x00C4	R/W	xx000000
Serial Port A Extended Register	SAER	0x00C5	R/W	00000000
Serial Port A Divider Low Register	SADLR	0x00C6	R/W	xxxxxxx
Serial Port A Divider High Register	SADHR	0x00C7	R/W	0xxxxxxx
Serial Port B Data Register	SBDR	0x00D0	R/W	xxxxxxx
Serial Port B Address Register	SBAR	0x00D1	W	xxxxxxx
Serial Port B Long Stop Register	SBLR	0x00D2	W	xxxxxxx
Serial Port B Status Register	SBSR	0x00D3	R	0xx00000
Serial Port B Control Register	SBCR	0x00D4	R/W	xx000000
Serial Port B Extended Register	SBER	0x00D5	R/W	00000000
Serial Port B Divider Low Register	SBDLR	0x00D6	R/W	xxxxxxx
Serial Port B Divider High Register	SBDHR	0x00D7	R/W	0xxxxxxx
Serial Port C Data Register	SCDR	0x00E0	R/W	xxxxxxx
Serial Port C Address Register	SCAR	0x00E1	W	xxxxxxx
Serial Port C Long Stop Register	SCLR	0x00E2	W	xxxxxxx
Serial Port C Status Register	SCSR	0x00E3	R	0xx00000
Serial Port C Control Register	SCCR	0x00E4	R/W	xx000000
Serial Port C Extended Register	SCER	0x00E5	R/W	00000000
Serial Port C Divider Low Register	SCDLR	0x00E6	R/W	xxxxxxx
Serial Port C Divider High Register	SCDHR	0x00E7	R/W	0xxxxxxx
Serial Port D Data Register	SDDR	0x00F0	R/W	xxxxxxx
Serial Port D Address Register	SDAR	0x00F1	W	xxxxxxx
Serial Port D Long Stop Register	SDLR	0x00F2	W	xxxxxxx
Serial Port D Status Register	SDSR	0x00F3	R	0xx00000
Serial Port D Control Register	SDCR	0x00F4	R/W	xx000000
Serial Port D Extended Register	SDER	0x00F5	R/W	00000000
Serial Port D Divider Low Register	SDDLRL	0x00F6	R/W	xxxxxxx
Serial Port D Divider High Register	SDDHR	0x00F7	R/W	0xxxxxxx

## 17.2 Dependencies

### 17.2.1 I/O Pins

Serial Port A can transmit on parallel port pins PC7, PC6, or PD6, and can receive on pins PC7, PD7, or PE7. If the clocked serial mode is enabled, the serial clock is either transmitted or received on PB1. When an internal clock is selected in the clocked serial mode, PB1 is automatically enabled as a clock output.

Serial Port B can transmit on parallel port pins PC5, PC4, or PD4, and can receive on pins PC5, PD5, or PE5. If the clocked serial mode is enabled, the serial clock is either transmitted or received on PB0. When an internal clock is selected in the clocked serial mode, PB0 is automatically enabled as a clock output.

Serial Port C can transmit on parallel port pins PC3 or PC2, and can receive on pins PC3, PD3, or PE3. If the clocked serial mode is enabled, the serial clock can be transmitted on PC7, PD7, PD2, or PE7, and can be received on PD2 or PE2.

**NOTE:** When Serial Port C is used as a clocked serial port, the parallel port pin used to transmit the serial clock will not be available for other use.

Serial Port D can transmit on parallel port pins PC1 or PC0, and can receive on pins PC1, PD1, or PE1. If the clocked serial mode is enabled, the serial clock can be transmitted on PC3, PD3, PD0, or PE3, and can be received on PD0 or PE0.

**NOTE:** When Serial Port D is used as a clocked serial port, the parallel port pin used to transmit the serial clock will not be available for other use.

**Table 17-2. Pin Usage Serial Ports A – D**

Function	Serial Port A	Serial Port B	Serial Port C	Serial Port D
Transmit	PC7, PC6, PD6	PC5, PC4, PD4	PC3, PC2	PC1, PC0
Receive	PC7, PD7, PE7	PC5, PD5, PE5	PC3, PD3, PE3	PC1, PD1, PE1
Transmit Clock	PB1	PB0	PC7, PD7, PD2, PE7, PH7	PC3, PD3, PD0, PE3, PH3
Receive Clock	PB1	PB0	PD2, PE2	PD0, PE0

### 17.2.2 Clocks

The data clocks for Serial Ports A – D are based on the peripheral clock and are divided by either a Timer A divider or a dedicated 15-bit divider. In either case, the overall clock divider will be the value in the appropriate register plus one.

### 17.2.3 Other Registers

Register	Function
TAT4R	Time constant for Serial Port A
TAT5R	Time constant for Serial Port B
TAT6R	Time constant for Serial Port C
TAT7R	Time constant for Serial Port D
PCFR, PCAHR, PCALR PDFR, PDAHR, PDALR PEFR, PEAHR, PEALR	Alternate port output selection

### 17.2.4 Interrupts

A serial port interrupt can be generated whenever one of the following occurs.

- A byte is available in the receive buffer.
- A byte is moved from the transmit buffer to the transmitter.
- A byte has been sent out of the transmitter and the transmit buffer is empty.

These occurrences correspond to bits 2, 3, and 7 of the Serial Port Status Registers.

The serial port interrupt vectors are located in the IIR as follows.

- Serial Port A at offset 0x0C0
- Serial Port B at offset 0x0D0
- Serial Port C at offset 0x0E0
- Serial Port D at offset 0x0F0

Each of them can be set as Priority 1, 2, or 3 in SxCR, where x is A – D for the four serial ports.

## 17.3 Operation

### 17.3.1 Asynchronous Mode

The following steps explain how to set up Serial Ports A – D for asynchronous operation. The serial ports can be used by polling the status byte, but their performance will be better with an interrupt. These instructions also apply to the asynchronous operation of Serial Ports E – F.

1. Write the interrupt vector for the interrupt service routine to the internal interrupt table.
2. Set up the desired transmit pin by writing to the appropriate parallel port function register (PxFR) and alternate output register (PxALR or PxAHR).
3. Select the appropriate mode by writing to SxCR (receive input port and 7 or 8 bits). Also select the interrupt priority.
4. Select additional options by writing to SxER (parity, RZI encoding, clock polarity, and behavior during break).
5. Write the desired divider value to TATxR for the appropriate serial port, or else write a divider value to the dedicated 15-bit divider in SxDLR and SxDHR. If the dedicated divider is to be used, write a 1 to the most-significant bit of SxDHR to enable it.

A sample asynchronous serial interrupt handler is shown below for Serial Port A.

```
async_sera_isr::
    push af                ; save used registers
    ioi ld a, (SASR)      ; get status
    bit a,7                ; check if byte ready in RX buffer
    push af                ; save status for next check
    jr z, check_for_tx
rx_ready:
    ioi ld a, (SADR)      ; read byte and clear interrupt

    ; do something with byte here

check_for_tx:
    pop af
    bit a,3                ; check if TX buffer was emptied
    jr nz, done

    ; get next byte to be transmitted into A here

    ioi ld (SADR), a      ; load next byte into TX buffer and clear interrupt
done:
    pop af                ; restore used registers
    ipres
    ret
```

To transmit with an address (1) bit appended, write the data to SxAR instead of SxDR; to append a stop (0) bit write to SxLR instead.

### 17.3.2 Clocked Serial Mode

The following steps explain how to set up Serial Ports A – D for the clocked serial mode. When the internal clock is selected, the Rabbit 5000 is in control of all transmit and receive operations. When an external clock is selected the other device controls all transmit and receive operation. For both situations the decision between polling and interrupt-driven methods is application dependent.

1. Write the interrupt vector for the interrupt service routine to the internal interrupt table.
2. Set up the desired data transmit and clock pins by writing to the appropriate parallel port function register (PxFR) and alternate output register (PxALR or PxAHR).
3. Select the appropriate mode by writing to SxCR (receive input port and clock source). Also select the interrupt priority.
4. Select additional options by writing to SxER (clock polarity, bit order, and clock source if external).
5. Write the desired divider value to TATxR for the appropriate serial port, or else write a divider to the dedicated 15-bit divider in SxDLR and SxDHR. If the dedicated divider is to be used, write a 1 to the most-significant bit of SxDHR to enable it.
6. There are two methods to transfer a byte:
  - write the byte to SxDR and then write 10 (or 11) to bits 6-7 of SxCR to enable the transfer;
  - write the byte to SxAR which will automatically start the transfer.If the internal clock is selected, the transmission will begin immediately; if an external clock is selected, the transmission will begin when the clock is detected.
7. To receive a byte, write 01 to bits 6-7 of SxCR to start the receive operation. If the internal clock is selected, the clock will begin immediately and the data will be read; if an external clock is selected, the receive will occur when the clock is detected.



A sample clocked serial interrupt handler is shown below for Serial Port B.

```
clocked_serb_isr:
    push af                ; save used registers
    ioi ld a, (SASR)      ; get status
    bit a,7               ; check if byte ready in RX buffer
    push af               ; save status for next check
    jr z, check_for_tx
rx_ready:
    ioi ld a, (SADR)      ; read byte and clear interrupt

    ; do something with received byte here

    ld a, 0x41           ; set bits 6-7 to 01, the other bits should
                        ; represent the desired SACR setup

    ioi ld (SACR), a     ; start a new receive operation

check_for_tx:
    pop af
    bit a,3              ; check if TX buffer was emptied
    jr nz, done

    ; get next byte to be transmitted into A here

    ioi ld (SADR), a     ; load TX buffer with next byte and clear interrupt
done:
    pop af                ; restore used registers
    ipres
    ret
```

## 17.4 Register Descriptions

Serial Port x Data Register		
		(SADR) (Address = 0x00C0)
		(SBDR) (Address = 0x00D0)
		(SCDR) (Address = 0x00E0)
		(SDDR) (Address = 0x00F0)
Bit(s)	Value	Description
7:0	Read	Returns the contents of the receive buffer.
	Write	Loads the transmit buffer with a data byte for transmission.

Serial Port x Address Register		
		(SAAR) (Address = 0x00C1)
		(SBAR) (Address = 0x00D1)
		(SCAR) (Address = 0x00E1)
		(SDAR) (Address = 0x00F1)
Bit(s)	Value	Description
7:0	Read	Returns the contents of the receive buffer. Reading the data from this register in the clocked serial mode automatically causes the receiver to start a byte-receive operation, eliminating the need for software to issue the start-receive command.
	Write	Loads the transmit buffer with an address byte, marked with a “zero” address bit, for transmission. Writing the data to this register in the clocked serial mode causes the transmitter to start a byte-transmit operation, eliminating the need for the software to issue the start-transmit command.

Serial Port x Long Stop Register		
		(SALR) (Address = 0x00C2)
		(SBLR) (Address = 0x00D2)
		(SCLR) (Address = 0x00E2)
		(SDLR) (Address = 0x00F2)
Bit(s)	Value	Description
7:0	Read	Returns the contents of the receive buffer.
	Write	Loads the transmit buffer with an address byte, marked with a “one” address bit, for transmission.

Serial Port x Status Register (Asynchronous Mode Only)			(SASR) (SBSR) (SCSR) (SDSR)	(Address = 0x00C3) (Address = 0x00D3) (Address = 0x00E3) (Address = 0x00F3)
Bit(s)	Value	Description		
7	0	The receive data register is empty		
	1	There is a byte in the receive buffer. The serial port will request an interrupt while this bit is set. The interrupt is cleared when the receive buffer is empty.		
6	0	The byte in the receive buffer is data, received with a valid stop bit.		
	1	The byte in the receive buffer is an address, or a byte with a framing error. If an address bit is not expected, and the data in the buffer is all zeros, this is a break.		
5	0	The receive buffer was not overrun.		
	1	The receive buffer was overrun. This bit is cleared by reading the receive buffer.		
4	0	The byte in the receive buffer has no parity error (or was not checked for parity).		
	1	The byte in the receive buffer had a parity error.		
3	0	The transmit buffer is empty.		
	1	The transmit buffer is not empty. The serial port will request an interrupt when the transmitter takes a byte from the transmit buffer. Transmit interrupts are cleared when the transmit buffer is written, or any value (which will be ignored) is written to this register.		
2	0	The transmitter is idle.		
	1	The transmitter is sending a byte. An interrupt is generated when the transmitter clears this bit, which occurs only if the transmitter is ready to start sending another byte and the transmit buffer is empty.		
1:0	00	These bits are always zero in the asynchronous mode.		

<b>Serial Port x Status Register</b> <b>(Clocked Serial Mode Only)</b>			<b>(SASR)</b> <b>(SBSR)</b> <b>(SCSR)</b> <b>(SDSR)</b>	<b>(Address = 0x00C3)</b> <b>(Address = 0x00D3)</b> <b>(Address = 0x00E3)</b> <b>(Address = 0x00F3)</b>
<b>Bit(s)</b>	<b>Value</b>	<b>Description</b>		
7	0	The receive data register is empty.		
	1	There is a byte in the receive buffer. The serial port will request an interrupt while this bit is set. The interrupt is cleared when the receive buffer is empty.		
6	0	This bit is always zero in the clocked serial mode.		
5	0	The receive buffer was not overrun.		
	1	The receive buffer was overrun. This bit is cleared by reading the receive buffer.		
4	0	This bit is always zero in the clocked serial mode.		
3	0	The transmit buffer is empty.		
	1	The transmit buffer is not empty. The serial port will request an interrupt when the transmitter takes a byte from the transmit buffer. Transmit interrupts are cleared when the transmit buffer is written, or any value (which will be ignored) is written to this register.		
2	0	The transmitter is idle.		
	1	The transmitter is sending a byte. An interrupt is generated when the transmitter clears this bit, which occurs only if the transmitter is ready to start sending another byte and the transmit buffer is empty.		
1:0	00	These bits are always zero in the clocked serial mode.		

<b>Serial Port x Control Register</b>		
		<b>(SACR)</b> <b>(Address = 0x00C4)</b> <b>(SBCR)</b> <b>(Address = 0x00D4)</b> <b>(SCCR)</b> <b>(Address = 0x00E4)</b> <b>(SDCR)</b> <b>(Address = 0x00F4)</b>
<b>Bit(s)</b>	<b>Value</b>	<b>Description</b>
7:6	00	No operation. These bits are ignored in the asynchronous mode.
	01	In the clocked serial mode, start a byte-receive operation.
	10	In the clocked serial mode, start a byte-transmit operation.
	11	In the clocked serial mode, start a byte-transmit operation and a byte-receive operation simultaneously.
5:4	00	Parallel Port C is used for input.
	01	Parallel Port D is used for input.
	10	Parallel Port E is used for input.
	11	Disable the receiver input.
3:2	00	Asynchronous mode with 8 bits per character.
	01	Asynchronous mode with 7 bits per character. In this mode the most significant bit of a byte is ignored for transmit, and is always zero in receive data.
	10	Clocked serial mode with external clock.
	11	Clocked serial mode with internal clock.
1:0	00	The serial port interrupt is disabled.
	01	The serial port uses Interrupt Priority 1.
	10	The serial port uses Interrupt Priority 2.
	11	The serial port uses Interrupt Priority 3.

Serial Port x Extended Register (Asynchronous Mode Only)			(SAER) (SBER) (SCER) (SDER)	(Address = 0x00C5) (Address = 0x00D5) (Address = 0x00E5) (Address = 0x00F5)
Bit(s)	Value	Description		
7:5	000	Disable parity generation and checking.		
	001	This bit combination is reserved and should not be used.		
	010	This bit combination is reserved and should not be used.		
	011	This bit combination is reserved and should not be used.		
	100	Enable parity generation and checking with even parity.		
	101	Enable parity generation and checking with odd parity.		
	110	Enable parity generation and checking with space (always zero) parity.		
	111	Enable parity generation and checking with mark (always one) parity.		
4	0	Normal asynchronous data encoding.		
	1	Enable RZI coding (3/16 bit cell IrDA-compliant).		
3	0	Normal break operation. This option should be selected when address bits are expected.		
	1	Fast break termination. At the end of break, a dummy character is written to the buffer, and the receiver can start character assembly after one bit time.		
2	0	Asynchronous clock is 16× data rate.		
	1	Asynchronous clock is 8× data rate.		
1	0	Continue character assembly during break to allow timing the break condition.		
	1	Inhibit character assembly during break. One character (all zeros, with framing error) at start and one character (garbage) at completion.		
0		This bit is ignored in the asynchronous mode.		

<b>Serial Port x Extended Register</b> <b>(Clocked Serial Mode Only)</b>			<b>(SAER)</b> <b>(SBER)</b> <b>(SCER)</b> <b>(SDER)</b>	<b>(Address = 0x00C5)</b> <b>(Address = 0x00D5)</b> <b>(Address = 0x00E5)</b> <b>(Address = 0x00F5)</b>
Bit(s)	Value	Description		
7	0	Normal clocked serial operation.		
	1	Timer-synchronized clocked serial operation.		
6	0	Timer-synchronized clocked serial uses Timer B1.		
	1	Timer-synchronized clocked serial uses Timer B2.		
5:4	00	Normal clocked serial clock polarity, inactive high. Internal or external clock.		
	01	Normal clocked serial clock polarity, inactive low. Internal clock only.		
	10	Inverted clocked serial clock polarity, inactive low. Internal or external clock.		
	11	Inverted clocked serial clock polarity, inactive high. Internal clock only.		
3	0	Normal bit order (LSB first) for transmit and receive.		
	1	Reverse bit order (MSB first) for transmit and receive.		
2	0	Serial clock (input mode only) from Parallel Port D (SCER and SDER only).		
	1	Serial clock (input mode only) from Parallel Port E (SCER and SDER only).		
1	0	No effect on transmitter.		
	1	Terminate current clocked serial transmission. No effect on buffer.		
0	0	No effect on receiver.		
	1	Terminate current clocked serial reception.		

<b>Serial Port x Divider Low Register</b>			<b>(SADLR)</b> <b>(SBDLR)</b> <b>(SCDLR)</b> <b>(SDDLRL)</b>	<b>(Address = 0x00C6)</b> <b>(Address = 0x00D6)</b> <b>(Address = 0x00E6)</b> <b>(Address = 0x00F6)</b>
Bit(s)	Value	Description		
7:0		Eight LSBs of the divider that generates the serial clock for this channel. This divider is not used unless the MSB of the corresponding SxDHR is set to one.		

Serial Port x Divider High Register		
		(SADHR) (Address = 0x00C7)
		(SBDHR) (Address = 0x00D7)
		(SCDHR) (Address = 0x00E7)
		(SDDHR) (Address = 0x00F7)
Bit(s)	Value	Description
7	0	Disable the serial port divider and use the output of Timer A to clock the serial port.
	1	Enable the serial port divider, and use its output to clock the serial port. The serial port divider counts modulo $n + 1$ and is clocked by the peripheral clock.
6:0		Seven MSBs of the divider that generates the serial clock for this channel.



# 18. SERIAL PORTS E – F

## 18.1 Overview

Serial Ports E and F are identical to each other, and their asynchronous operation is identical to that of Serial Ports A – D except for the source of the data clock, the buffer sizes, and the transmit, receive, and clock pins. Each serial port can be used in the asynchronous or the HDLC mode with an internal or external clock.

In the asynchronous mode, either 7 or 8 data bits can be transferred, and both a parity bit and/or ninth data bit can be appended as well. Parity and the ninth data bits are also detected when they are received. The asynchronous mode is full-duplex.

The transmit and receive buffers of Serial Ports E and F have 4 bytes each; this reduces the interrupt overhead requirements because an interrupt does not have to be generated as often. A serial port interrupt is generated whenever at least one byte is available in the receive buffer or whenever a byte is shifted out of the transmit buffer.

The status of each serial port is available in its Serial Port Status Register (SxSR), and contains information on whether a received byte is available, the receive buffer was overrun, a parity error was received, the transmit buffer is empty or busy sending a byte, and the state of the ninth data bit (whether it is an address bit or a stop bit).

Serial Ports E and F support the HDLC mode with either an internal or an external clock; separate pins may be used for the transmit and receive clocks, or the transmit and receive clocks may be combined onto a single pin. The HDLC packet flag encapsulation, flag escapes, and CRC calculation and check are handled automatically by the processor. The serial port can detect end-of-frame, short-frame, and CRC errors. Interrupts are generated by the reception of an end-of-frame, at the end of a transmission of a CRC, by an abort sequence, or by a closing flag. Transmit and receive operations are essentially automatic.

The standard CRC-CCITT polynomial ( $x^{16} + x^{12} + x^5 + 1$ ) is implemented for the CRC, with the generator and checker preset to all ones.

It is possible to send packets with or without a CRC appended. It is also possible to select whether an abort or flag will be transmitted if the transmitter underflows. A packet under transition can be aborted and the abort pattern sent. The idle condition of the line can be flags or all ones.

Several types of data encoding are available in HDLC mode: NRZ, NRZI, biphas-level (Manchester), biphas-space (FM0), and biphas-mark (FM1). IrDA-compliant RZI

encoding is also available in HDLC mode; it reduces the bit widths to  $\frac{1}{4}$  the normal width, which allows the serial-port signal to be connected directly to an IrDA transceiver.

If an internal clock is selected, the serial port data clocks can be generated from the appropriate 8-bit timer (Timer A2 for Serial Port E and Timer A3 for Serial Port F) or from a dedicated 15-bit divider. In HDLC mode, the byte data rate is equal to the data clock rate divided by 16.

When using an external clock, a  $1\times$  (same speed as the data rate) clock is supported. In this case, the maximum data rate is  $\frac{1}{6}$  of the peripheral clock rate. The receive clock is generated from the transitions in the data stream via a digital phase-locked loop (DPLL). The timing of this synchronization is adjusted with each incoming transition, allowing for tracking if the two external clocks differ slightly in frequency. For more on the clock synchronization and data encoding, see Section 18.3.3.

### 18.1.1 Block Diagram

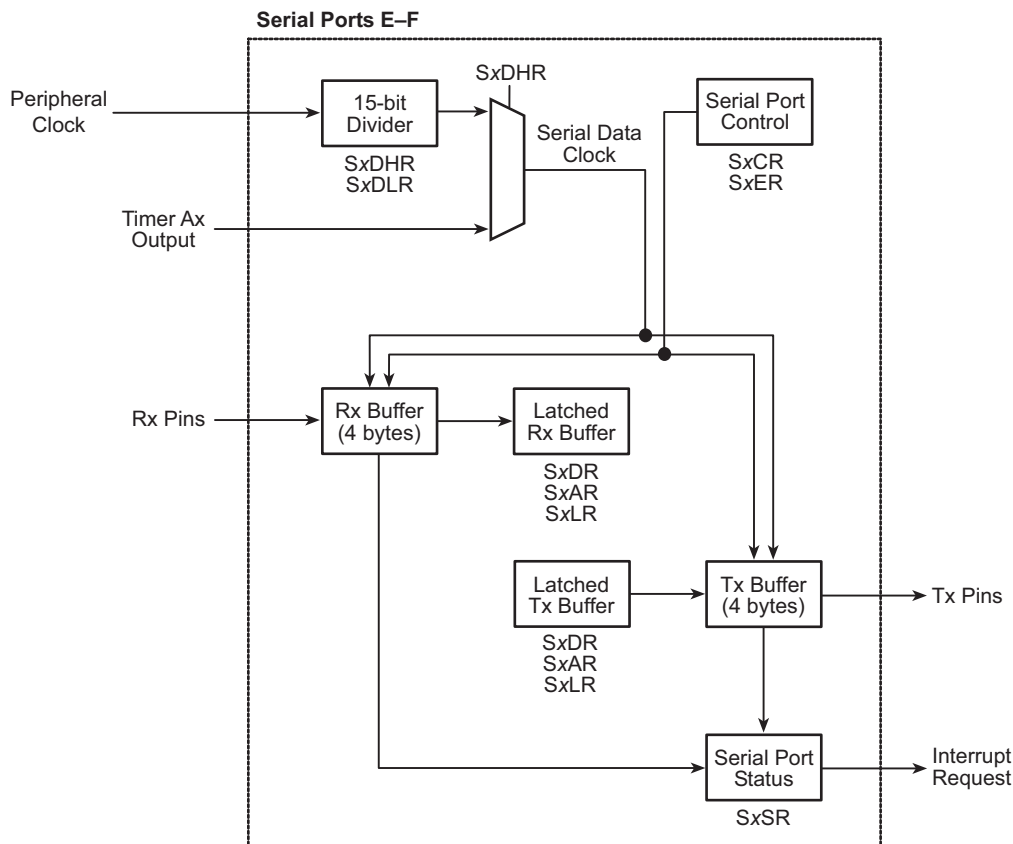

## 18.1.2 Registers

Register Name	Mnemonic	I/O Address	R/W	Reset
Serial Port E Data Register	SEDR	0x00C8	R/W	xxxxxxx
Serial Port E Address Register	SEAR	0x00C9	W	xxxxxxx
Serial Port E Long Stop Register	SELR	0x00CA	W	xxxxxxx
Serial Port E Status Register	SESR	0x00CB	R	0xx00000
Serial Port E Control Register	SECR	0x00CC	R/W	xx000000
Serial Port E Extended Register	SEER	0x00CD	R/W	00000000
Serial Port E Divider Low Register	SEDLR	0x00CE	R/W	xxxxxxx
Serial Port E Divider High Register	SEDHR	0x00CF	R/W	0xxxxxxx
Serial Port F Data Register	SFDR	0x00D8	R/W	xxxxxxx
Serial Port F Address Register	SFAR	0x00D9	W	xxxxxxx
Serial Port F Long Stop Register	SFLR	0x00DA	W	xxxxxxx
Serial Port F Status Register	SFSR	0x00DB	R	0xx00000
Serial Port F Control Register	SFCR	0x00DC	R/W	xx000000
Serial Port F Extended Register	SFER	0x00DD	R/W	00000000
Serial Port F Divider Low Register	SFDLR	0x00DE	R/W	xxxxxxx
Serial Port F Divider High Register	SFDHR	0x00DF	R/W	0xxxxxxx

## 18.2 Dependencies

### 18.2.1 I/O Pins

Serial Port E can transmit on parallel port pins PC6, PD6, PE6, or PH6, and can receive on pins PC7, PD7, or PE7. If the HDLC mode is enabled, the transmit serial clock is either transmitted or received on PC4, PD4, or PE4, while the receive serial clock is either transmitted or received on PC5, PD5, or PE5. The transmit and receive clocks can also be transmitted on PH4 or PH0 if internal clock mode is enabled.

Serial Port F can transmit on parallel port pins PC2, PD2, PE2, or PH2, and can receive on pins PC3, PD3, or PE3. If the HDLC mode is enabled, the transmit serial clock is either transmitted or received on PC0, PD0, or PE0, while the receive serial clock is either transmitted or received on PC1, PD1, or PE1. The transmit and receive clocks can also be transmitted on PH5 or PH1 if internal clock mode is enabled.

**Table 18-1. Serial Ports E and F Pin Usage**

Function	Serial Port E	Serial Port F
Transmit	PC6, PD6, PE6, PH6	PC2, PD2, PE2, PH2
Receive	PC7, PD7, PE7	PC3, PD3, PE3
Transmit Clock	PC4, PD4, PE4, PH4	PC0, PD0, PE0, PH0
Receive Clock	PC5, PD5, PE5, PH5	PC1, PD1, PE1, PH1

### 18.2.2 Clocks

The data clocks for Serial Ports E – F are based on the peripheral clock and divided by either a Timer A divider or a dedicated 15-bit divider. In either case, the overall clock divider will be the value in the appropriate register plus one.

### 18.2.3 Other Registers

Register	Function
TAT2R	Time constant for Serial Port E
TAT3R	Time constant for Serial Port F
PCFR, PCAHR, PCALR PDFR, PDAHR, PDALR PEFR, PEAHR, PEALR PHFR, PHAHR, PHALR	Alternate port output selection

### 18.2.4 Interrupts

In the asynchronous mode, a serial port interrupt can be generated whenever one of the following occurs.

- A byte is available in the receive buffer.
- A byte is moved from the transmit buffer to the transmitter.
- A byte has been sent out of the transmitter and the transmit buffer is empty.

These occurrences correspond to bits 2, 3, and 7 of the Serial Port Status Registers.

In the HDLC mode, interrupts are also generated by the reception of an end-of-frame (with abort, valid CRC, or CRC error), at the end of a transmission of a CRC, by an abort sequence, or by a closing flag.

The serial port interrupt vectors are located in the IIR as follows.

- Serial Port E at offset 0x1C0
- Serial Port F at offset 0x1D0

Each of them can be set as Priority 1, 2, or 3 in SxCR, where x is E – F for the two serial ports.

## 18.3 Operation

### 18.3.1 Asynchronous Mode

The steps to set up Serial Ports E – F for asynchronous operation are identical to those described in Section 17.3.1 to set up Serial Ports A – D.

### 18.3.2 HDLC Mode

The following steps explain how to set up Serial Ports E – F for the HDLC mode.

1. Write the interrupt vector for the interrupt service routine to the internal interrupt table.
2. Set up the desired data transmit and clock pins by writing to the appropriate parallel port function register (PxFR) and alternate output register (PxALR or PxAHR).
3. Select the appropriate mode by writing to SxCR (receive input port and clock source). Also select the interrupt priority.
4. Select additional options by writing to SxER (data encoding, idle line condition, under-run behavior, and combined or separate clocks).
5. Write the desired divider value to TATxR for the appropriate serial port, or else write a divider to the dedicated 15-bit divider in SxDLR and SxDHR. If the dedicated divider is to be used, write a 1 to the most-significant bit of SxDHR to enable it. In either case, the overall clock divider will be the value in the appropriate register plus one.
6. To start transmission of a packet, write the first byte to SxDR. If internal clock is selected, the transmission will begin immediately; if an external clock is selected the transmission will begin when the clock is detected.
7. Continue writing bytes when space is available in the transmit buffer until the final byte of the packet. If a CRC is to be appended to the packet, write the final byte to SxAR. If no CRC is required, write the final byte to SxLR and just a closing flag will be appended. If it is desirable to abort the current packet, write 11 to bits 6–7 of SxCR, and an abort pattern will be transmitted.
8. The receiver will be synchronized on flag bytes and will reset the CRC. By monitoring the received bytes, decisions can be made about the incoming packet; if it is not desired (i.e., it is not addressed to this device), writing a 01 to bits 6–7 of SxCR will force the receiver back into the flag search mode.

A sample HDLC interrupt handler is shown below for Serial Port E.

```

hdlc_sere_isr::
    push af
    ioi ld a, (SESR)    ; get status
    bit a,7            ; check if byte ready in RX buffer
    push af            ; save status for next check
    jr z, check_for_tx
rx_ready:

    ; check status byte in A for abort or invalid CRC flags

    ioi ld a, (SEDR)    ; read byte and clear interrupt

    ; store byte in A here

check_for_tx:
    pop af
    bit a,3            ; check if TX buffer was emptied
    jr nz, done

    ; check status byte in A for transmit finish reason (CRC, abort, etc.)

    ; get next byte to be transmitted into A here; if it is the last
    ; byte of the packet, load it into SEAR or SELR instead

    ioi ld (SEDR), a    ; load next byte into buffer and clear interrupt
done:
    pop af
    ipres
    ret

```

### 18.3.3 More on Clock Synchronization and Data Encoding

The transmitter is not capable of sending an arbitrary number of bits, but only a multiple of bytes. However, the receiver can receive frames of any bit length. If the last “byte” in the frame is not eight bits, the receiver sets a status flag that is buffered along with this last byte. Software can then use the table below to determine the number of valid data bits in this last “byte.” Note that the receiver transfers all bits between the opening and closing flags, except for the inserted zeros, to the receiver data buffer.

Last Byte Bit Pattern	Valid Data Bits
bbbbbbb0	7
bbbbbb01	6
bbbb011	5
bbb0111	4
bb01111	3
b011111	2
0111111	1

Several types of data encoding are available in the HDLC mode. In addition to the normal NRZ, they are NRZI, biphas-level (Manchester), biphas-space (FM0), and biphas-mark (FM1). Examples of these encodings are shown below. Note that the signal level does not convey information in NRZI, biphas-space, and biphas-mark. Instead it is the placement of the transitions that determine the data. In biphas-level it is the polarity of the transition that determines the data.

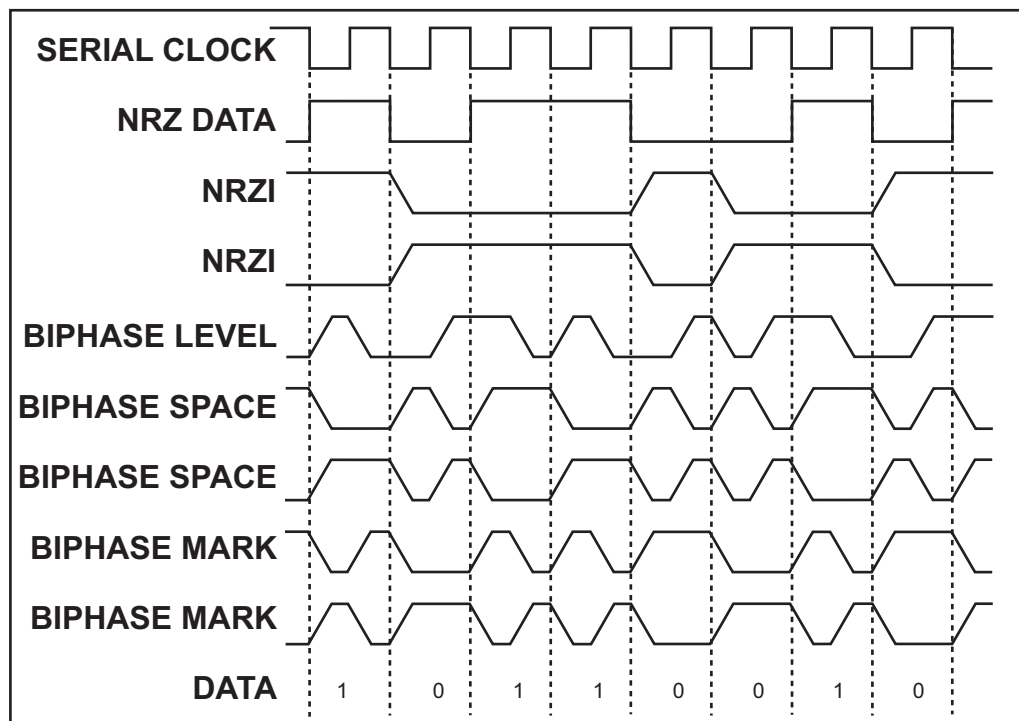

**Figure 18-1. Examples of Data Encoding In the HDLC Mode**

In the HDLC mode the internal clock comes from the output of Timer A2/Timer A3 or the dedicated divider. The timer/divider output is divided by 16 to form the transmit clock, and is fed to the digital phase-locked loop (DPLL) to form the receive clock. The DPLL is basically just a divide-by-16 counter that uses the timing of the transitions on the receive data stream to adjust its count. The DPLL adjusts the count so that the DPLL output will be properly placed in the bit cells to sample the receive data. To work properly, then, transitions are required in the receive data stream. NRZ data encoding does not guarantee transitions in all cases (a long string of zeros, for example), but the other data encodings do. NRZI guarantees transitions because of the inserted zeros, and the biphas encodings all have at least one transition per bit cell.

The DPLL counter normally counts by 16, but if a transition occurs earlier or later than expected, the count will be modified during the next count cycle. If the transition occurs earlier than expected, it means that the bit cell boundaries are early with respect to the DPLL-tracked bit-cell boundaries, so the count is shortened by either one or two counts. If the transition occurs later than expected, it means that the bit-cell boundaries are late with



respect to the DPLL-tracked bit-cell boundaries, so the count is lengthened by either one or two counts. The decision to adjust by one or by two depends on how far off the DPLL-tracked bit cell boundaries are. This tracking allows for minor differences in the transmit and receive clock frequencies.

With NRZ and NRZI data encoding, the DPLL counter runs continuously, and adjusts after every receive data transition. Since NRZ encoding does not guarantee a minimum density of transitions, the difference between the sending data rate and the DPLL output clock rate must be very small, and depends on the longest possible run of zeros in the received frame. NRZI encoding guarantees at least one transition every six bits (with the inserted zeros). Since the DPLL can adjust by two counts every bit cell, the maximum difference between the sending data rate and the DPLL output clock rate is  $1/48$  (~2%).

With biphasic data encoding (either biphasic-level, biphasic-mark, or biphasic-space), the DPLL runs only as long as transitions are present in the receive data stream. Two consecutive missed transitions causes the DPLL to halt operation and wait for the next available transition. This mode of operation is necessary because it is possible for the DPLL to lock onto the optional transitions in the receive data stream. Since they are optional, they will eventually not be present, and the DPLL can attempt to lock onto the required transitions. Since the DPLL can adjust by one count every bit cell, the maximum difference between the sending data rate and the DPLL output clock rate is  $1/16$  (~6%).

With biphasic data encoding, the DPLL is designed to work in multiple-access conditions where there might not be flags on an idle line. The DPLL will generate an output clock correctly based on the first transition in the leading zero of an opening flag. Similarly, only the completion of the closing flag is necessary for the DPLL to provide the extra two clocks to the receiver to assemble the data correctly. The transition is specified as follows.

- In the biphasic-level mode this means the transition that defines the last zero of the closing flag.
- In the biphasic-mark and the biphasic-space modes this means the transition that defines the end of the last zero of the closing flag.

Figure 18-2 shows the adjustment ranges and output clock for the different modes of operation of the DPLL. Each mode of operation will be described in turn.

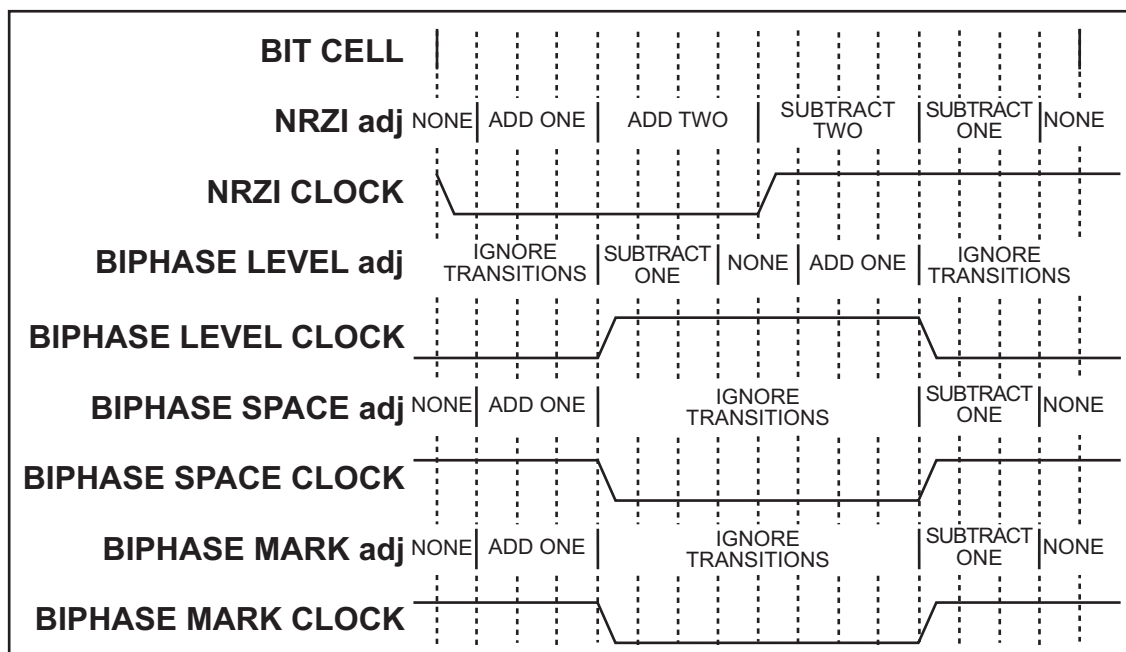

**Figure 18-2. Adjustment Ranges and Output Clock for Different DPLL Modes**

With NRZ and NRZI encoding, all transitions occur on bit-cell boundaries and the data should be sampled in the middle of the bit cell. If a transition occurs after the expected bit-cell boundary (but before the midpoint), the DPLL needs to lengthen the count to line up the bit-cell boundaries. This corresponds to the “add one” and “add two” regions shown. If a transition occurs before the bit-cell boundary (but after the midpoint), the DPLL needs to shorten the count to line up the bit-cell boundaries. This corresponds to the “subtract one” and “subtract two” regions shown. The DPLL makes no adjustment if the bit-cell boundaries are lined up within one count of the divide-by-16 counter. The regions that adjust the count by two allow the DPLL to synchronize faster to the data stream when starting up.

With biphase-level encoding, there is a guaranteed “clock” transition at the center of every bit cell and optional “data” transitions occur at the bit cell boundaries. The DPLL only uses the clock transitions to track the bit-cell boundaries by ignoring all transitions occurring outside a window around the center of the bit cell. This window is half a bit cell wide. Additionally, because the clock transitions are guaranteed, the DPLL requires that they always be present. If no transition is found in the window around the center of the bit cell for two successive bit cells, the DPLL is not in lock and immediately enters the search mode. The search mode assumes that the next transition seen is a clock transition and immediately synchronizes to this transition. No clock output is provided to the receiver during the search operation. Decoding biphase-level data requires that the data be sampled at either the quarter or three-quarter point in the bit cell. The DPLL here uses the quarter point to sample the data.

Biphase-mark encoding and biphase-space encoding are identical as far as the DPLL is concerned, and are similar to biphase-level encoding. The primary difference is the placement of the clock and data transitions. With these encodings the clock transitions are at the bit-cell boundary, the data transitions are at the center of the bit cell, and the DPLL operation is adjusted accordingly. Decoding biphase-mark or biphase-space encoding requires that the data be sampled by both edges of the recovered receive clock.

## 18.4 Register Descriptions

<b>Serial Port x Data Register</b>		<b>(SEDR)</b> <b>(SFDR)</b>	<b>(Address = 0x00C8)</b> <b>(Address = 0x00D8)</b>
<b>Bit(s)</b>	<b>Value</b>	<b>Description</b>	
7:0	Read	Returns the contents of the receive buffer.	
	Write	Loads the transmit buffer with a data byte for transmission.	

<b>Serial Port x Address Register</b>		<b>(SEAR)</b> <b>(SFAR)</b>	<b>(Address = 0x00C9)</b> <b>(Address = 0x00D9)</b>
<b>Bit(s)</b>	<b>Value</b>	<b>Description</b>	
7:0	Read	Returns the contents of the receive buffer.	
	Write	Loads the transmit buffer with an address byte, marked with a “zero” address bit, for transmission. In the HDLC mode, the last byte of a frame must be written to this register to enable subsequent CRC and closing flag transmission.	

<b>Serial Port x Long Stop Register</b>		<b>(SELR)</b> <b>(SFLR)</b>	<b>(Address = 0x00CA)</b> <b>(Address = 0x00DA)</b>
<b>Bit(s)</b>	<b>Value</b>	<b>Description</b>	
7:0	Read	Returns the contents of the receive buffer.	
	Write	Loads the transmit buffer with an address byte, marked with a “one” address bit, for transmission.	

<b>Serial Port x Status Register (Asynchronous Mode Only)</b>		<b>(SESR) (SFSR)</b>	<b>(Address = 0x00CB) (Address = 0x00DB)</b>
<b>Bit(s)</b>	<b>Value</b>	<b>Description</b>	
7	0	The receive data register is empty	
	1	There is a byte in the receive buffer. The serial port will request an interrupt while this bit is set. The interrupt is cleared when the receive buffer is empty.	
6	0	The byte in the receive buffer is data, received with a valid stop bit.	
	1	The byte in the receive buffer is an address, or a byte with a framing error. If an address bit is not expected, and the data in the buffer is all zeros, this is a break.	
5	0	The receive buffer was not overrun.	
	1	The receive buffer was overrun. This bit is cleared by reading the receive buffer.	
4	0	The byte in the receive buffer has no parity error (or was not checked for parity).	
	1	The byte in the receive buffer had a parity error.	
3	0	The transmit buffer is empty.	
	1	The transmit buffer is not empty. The serial port will request an interrupt when the transmitter takes a byte from the transmit buffer. Transmit interrupts are cleared when the transmit buffer is written, or any value (which will be ignored) is written to this register.	
2	0	The transmitter is idle.	
	1	The transmitter is sending a byte. An interrupt is generated when the transmitter clears this bit, which occurs only if the transmitter is ready to start sending another byte and the transmit buffer is empty.	
1:0	00	These bits are always zero in the asynchronous mode.	

<b>Serial Port x Status Register (HDLC Mode Only)</b>		<b>(SESR) (SFSR)</b>	<b>(Address = 0x00CB) (Address = 0x00DB)</b>
<b>Bit(s)</b>	<b>Value</b>	<b>Description</b>	
7	0	The receive data register is empty	
	1	There is a byte in the receive buffer. The serial port will request an interrupt while this bit is set. The interrupt is cleared when the receive buffer is empty.	
6,4	00	The byte in the receive buffer is data.	
	01	The byte in the receive buffer was followed by an abort.	
	10	The byte in the receive buffer is the last in the frame, with valid CRC.	
	11	The byte in the receive buffer is the last in the frame, with a CRC error.	
5	0	The receive buffer was not overrun.	
	1	The receive buffer was overrun. This bit is cleared by reading the receive buffer.	
3	0	The transmit buffer is empty.	
	1	The transmit buffer is not empty. The serial port will request an interrupt when the transmitter takes a byte from the transmit buffer, unless the byte is marked as the last in the frame. Transmit interrupts are cleared when the transmit buffer is written, or when any value (which will be ignored) is written to this register.	
2:1	00	Transmit interrupt due to buffer empty condition.	
	01	Transmitter finished sending CRC. An interrupt is generated at the end of the CRC transmission. Data written in response to this interrupt will cause only one flag to be transmitted between frames, and no interrupt will be generated by this flag.	
	10	Transmitter finished sending an abort. An interrupt is generated at the end of an abort transmission.	
	11	The transmitter finished sending a closing flag. Data written in response to this interrupt will cause at least two flags to be transmitted between frames.	
0	0	The byte in the receiver buffer is 8 bits.	
	1	The byte in the receiver buffer is less than 8 bits.	

<b>Serial Port x Control Register</b>		
		<b>(SECR)</b> <b>(SFCR)</b>
		<b>(Address = 0x00CC)</b> <b>(Address = 0x00DC)</b>
<b>Bit(s)</b>	<b>Value</b>	<b>Description</b>
7:6	00	No operation. These bits are ignored in the asynchronous mode.
	01	In HDLC mode, force receiver in flag search mode.
	10	No operation.
	11	In HDLC mode, transmit an abort pattern.
5:4	00	Parallel Port C is used for data (and optional clock) input.
	01	Parallel Port D is used for data (and optional clock) input.
	10	Parallel Port E is used for data (and optional clock) input.
	11	Disable the receiver data input. Clocks from Parallel Port E.
3:2	00	Asynchronous mode with 8 bits per character.
	01	Asynchronous mode with 7 bits per character. In this mode the most significant bit of a byte is ignored for transmit, and is always zero in receive data.
	10	HDLC mode with external clock. The external clocks are supplied via parallel port pins.
	11	HDLC mode with internal clock. The clock is 16× the data rate, and the DPLL is used to recover the receive clock. If necessary, the receiver and transmitter clocks can be output via parallel port pins.
1:0	00	The serial port interrupt is disabled.
	01	The serial port uses Interrupt Priority 1.
	10	The serial port uses Interrupt Priority 2.
	11	The serial port uses Interrupt Priority 3.

<b>Serial Port x Extended Register (Asynchronous Mode Only)</b>		<b>(SEER) (SFER)</b>	<b>(Address = 0x00CD) (Address = 0x00DD)</b>
<b>Bit(s)</b>	<b>Value</b>	<b>Description</b>	
7:5	000	Disable parity generation and checking.	
	001	This bit combination is reserved and should not be used.	
	010	This bit combination is reserved and should not be used.	
	011	This bit combination is reserved and should not be used.	
	100	Enable parity generation and checking with even parity.	
	101	Enable parity generation and checking with odd parity.	
	110	Enable parity generation and checking with space (always zero) parity.	
	111	Enable parity generation and checking with mark (always one) parity.	
4	0	Normal asynchronous data encoding.	
	1	Enable RZI coding (3/16 bit cell IrDA-compliant).	
3	0	Normal break operation. This option should be selected when address bits are expected.	
	1	Fast break termination. At the end of break, a dummy character is written to the buffer, and the receiver can start character assembly after one bit time.	
2	0	Asynchronous clock is 16× data rate.	
	1	Asynchronous clock is 8× data rate.	
1	0	Continue character assembly during break to allow timing the break condition.	
	1	Inhibit character assembly during break. One character (all zeros, with framing error) at start and one character (garbage) at completion.	
0		This bit is ignored in the asynchronous mode.	

<b>Serial Port x Extended Register (HDLC Mode Only)</b>		<b>(SEER) (SFER)</b>	<b>(Address = 0x00CD) (Address = 0x00DD)</b>
<b>Bit(s)</b>	<b>Value</b>	<b>Description</b>	
7:5	000	NRZ data encoding for HDLC receiver and transmitter.	
	010	NRZI data encoding for HDLC receiver and transmitter.	
	100	Biphase-level (Manchester) data encoding for HDLC receiver and transmitter.	
	110	Biphase-space data encoding for HDLC receiver and transmitter.	
	111	Biphase-mark data encoding for HDLC receiver and transmitter.	
4	0	Normal HDLC data encoding.	
	1	Enable RZI coding (¼ bit cell IrDA-compliant). This mode can only be used with an internal clock and NRZ data encoding.	
3	0	Idle line condition is flags.	
	1	Idle line condition is all ones.	
2	0	Transmit flag on underrun.	
	1	Transmit abort on underrun.	
1	0	Separate HDLC external receive and transmit clocks.	
	1	Combined HDLC external and transmit clock, from transmit clock pin.	
0		This bit is ignored in HDLC mode.	

<b>Serial Port x Divider Low Register</b>		<b>(SEDLR) (SFDLR)</b>	<b>(Address = 0x00CE) (Address = 0x00DE)</b>
<b>Bit(s)</b>	<b>Value</b>	<b>Description</b>	
7:0		Eight LSBs of the divider that generates the serial clock for this channel. This divider is not used unless the MSB of the corresponding SxDHR is set to one.	

<b>Serial Port x Divider High Register</b>		<b>(SEDHR) (SFDHR)</b>	<b>(Address = 0x00CF) (Address = 0x00DF)</b>
<b>Bit(s)</b>	<b>Value</b>	<b>Description</b>	
7	0	Disable the serial port divider and use the output of Timer A to clock the serial port.	
	1	Enable the serial port divider, and use its output to clock the serial port. The serial port divider counts modulo $n + 1$ and is clocked by the peripheral clock.	
6:0		Seven MSBs of the divider that generates the serial clock for this channel.	



# 19. SLAVE PORT

## 19.1 Overview

The slave port is a parallel communication port that can be used to communicate with an external master device. The slave port consists of three data input and data output registers, and a status register.

The data input registers are written by the master (the external device) and are read by the processor. The data output registers are written by the processor and are read by the master. Note that the data registers are named from the point of view of the processor. The slave device can only read the data input registers and write to the data output registers. Similarly, the master device can only read the data input registers and write the data output registers. Both devices can read and write to the status register.

The status register contains the interrupt status bits and a status flag corresponding to each data input or data output register to indicate the empty or full status of the data register. Data registers are marked full when written by the source side of the interface, and are marked empty when read by the destination side of the interface.

The hardware interface to the external master consists of an 8-bit bidirectional data bus with a read strobe, write strobe, and chip select. There are two address lines that select one of the three data registers or the status register.

**Table 19-1. Slave Port Addresses**

Slave Port Address	Slave Port Register
00	Data Register 0
01	Data Register 1
10	Data Register 2
11	Status Register

A slave attention signal is asserted when the processor writes to one of the slave port data registers (SPDOR), and can be deasserted by the master by performing a dummy write to the status register. This signal can be used to interrupt the master to indicate that the master needs to read data from the slave.

The slave port interrupt is asserted when the master writes to SPDOR. The processor clears this interrupt condition by writing to the status register.

The slave port can be used to bootstrap the processor by setting the SMODE pins appropriately. See Chapter 3 for more information on this mode.

### 19.1.1 Block Diagram

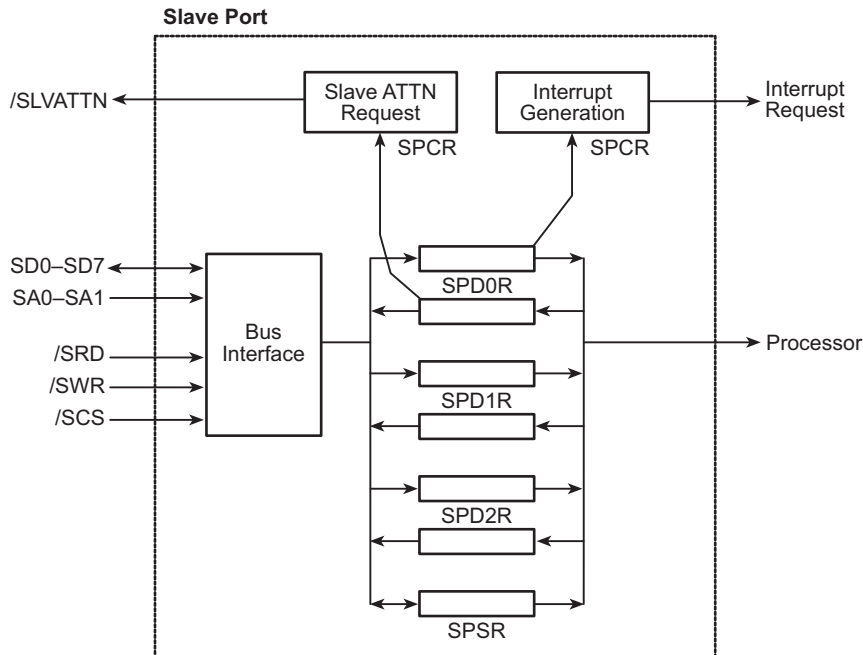

### 19.1.2 Registers

Register Name	Mnemonic	I/O Address	R/W	Reset
Slave Port Data 0 Register	SPD0R	0x0020	R/W	xxxxxxx
Slave Port Data 1 Register	SPD1R	0x0021	R/W	xxxxxxx
Slave Port Data 2 Register	SPD2R	0x0022	R/W	xxxxxxx
Slave Port Status Register	SPSR	0x0023	R	0000000
Slave Port Control Register	SPCR	0x0024	R/W	0xx0000

## 19.2 Dependencies

### 19.2.1 I/O Pins

When the slave port is enabled by writing to SPCR, the following pins are enabled for slave port mode. Note that enabling the slave port mode will override any general-purpose I/O or external I/O bus settings for these pins; when the slave port is enabled they will perform slave port functionality.

**Table 19-2. Slave Port Pin Functionality**

Pin(s)	Slave Port Signal	Direction	Functionality
PA0–PA7	SD0–SD7	Bidirectional	Slave data bus
PB7	/SLVATTN	Output	Slave interrupt request (output)
PB6	/SCS	Input	Slave chip select
PB4–PB5	SA0–SA1	Input	Slave address bus
PB3	/SRD	Input	Slave port read strobe
PB2	/SWR	Input	Slave port write strobe
PE7	/SCS	Input	Alternate slave chip select

### 19.2.2 Clocks

All slave port operations are based on the processor clock.

### 19.2.3 Interrupts

A slave port interrupt occurs on the slave device whenever the master writes to SPDOR. The /SLVATTN pin is asserted whenever the slave device writes to SPDOR. Either if these conditions is cleared when either the master or slave reads or writes any of the slave port registers.

The slave port interrupt vector is in the IIR at offset 0x080. It can be set as Priority 1, 2, or 3 by writing to SPCR.

### 19.3 Operation

Figure 19-1 shows a typical slave port connection between a Rabbit processor as the master and two slaves.

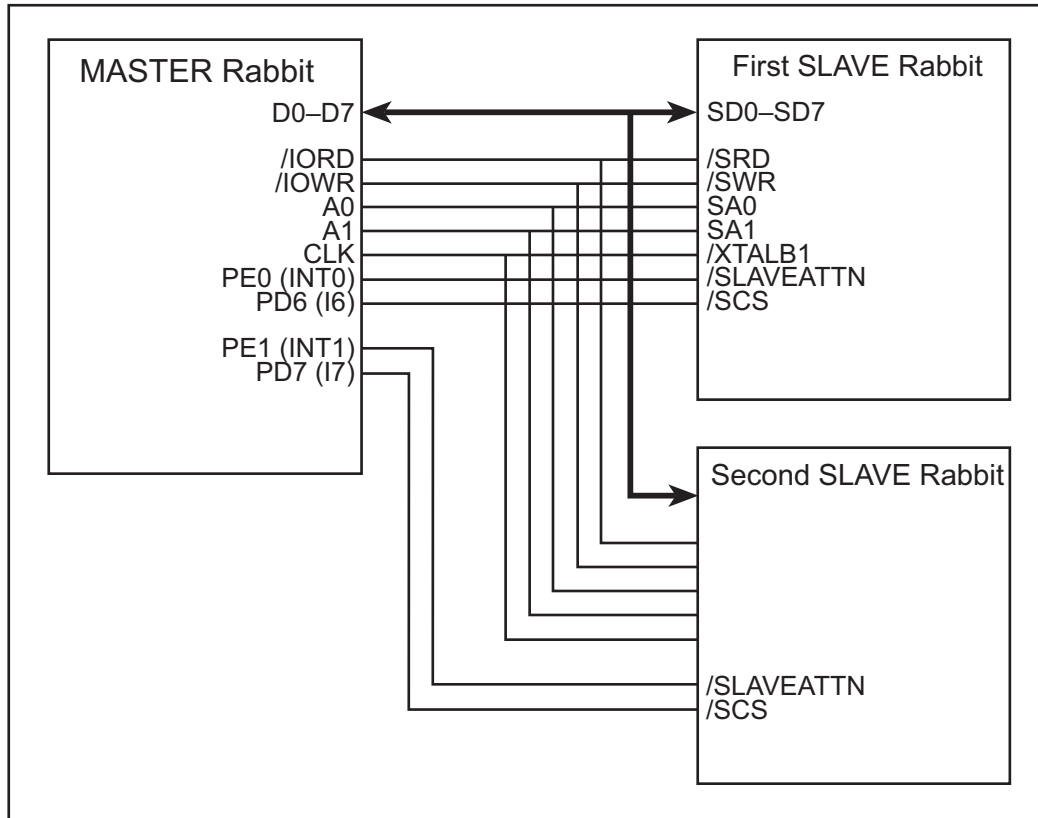

**Figure 19-1. Master/Slave Port Connections**

These connections are summarized in Table 19-3.

**Table 19-3. Typical Slave Port Connections**

Master		Slave #1		Slave #2	
Data Bus	D0–D7	SD0–SD7	PA0–PA7	SD0–SD7	PA0–PA7
Address Bus	A0–A1	SA0–SA1	PB4–PB5	SA0–SA1	PB4–PB5
I/O Read Strobe	/IORD	/SRD	PB3	/SRD	PB3
I/O Write Strobe	/IOWR	/SWR	PB2	/SWR	PB2
Slave #1 Chip Select (I/O strobe I6)	PD6	/SCS	PB6	—	—
Slave #2 Chip Select (I/O strobe I7)	PD7	—	—	/SCS	PB6
External Interrupt 0 (from Slave #1)	PE0	/SLVATTN	PB7	—	—
External Interrupt 1 (from Slave #2)	PE1	—	—	/SLVATTN	PB7

Note that the slave port on the master Rabbit processor is *not* used; the master uses the data bus to send and receive data to the slave port data registers on the slave devices.

In this setup, pins PD6 and PD7 are set up as I/O strobe chip selects for the two slave devices, and PE0 and PE1 are used as external interrupt inputs to monitor the /SLVATTN signals from the slaves.

In this setup, the slave port is used as follows:

- The slave responds to the interrupt and reads the slave port data registers.
- When the slave wishes to send data to the master, it writes the slave port data registers, writing SPD0R last, which enables the /SLVATTN signal.
- When the master detects the change on /SLVATTN, it reads the slave port data registers.

### 19.3.1 Master Setup

1. Enable the I/O strobes on PD6 and PD7 by writing to the appropriate Parallel Port D pin and external I/O registers.
2. Enable the external interrupts on PE0 and PE1 by writing to the appropriate external interrupt registers.

### 19.3.2 Slave Setup

1. Write the vector to the interrupt service routine to the internal interrupt table.
2. Configure SPCR to select the interrupt priority (note that interrupts will be enabled once this value is set).

### 19.3.3 Master/Slave Communication

1. The master writes data to the appropriate external I/O address on the data bus for the slave device and register desired. For example, in the setup described here, the master would write to register SPD2R on the first slave by writing to the address 0xC002 (0xC000 for the I6 strobe, and 0x0002 for SPD2R on that slave).
2. If the master is writing multiple bytes, it should write to SPD0R last since that will trigger an interrupt on the slave device. If only one byte is being sent, it should be written to SPD0R.
3. The slave responds to the interrupt, reading the data from the slave port data registers.

### 19.3.4 Slave/Master Communication

1. The slave writes data to the appropriate slave port data register. If it is writing multiple bytes, SPD0R should be written last, which enables the /SLVATTN line.
2. The master receives an external interrupt from the /SLVATTN line, and reads the data out of the slave port data registers via external I/O reads on the data bus.

### 19.3.5 Handling Interrupts

The interrupt request on the slave is cleared by either the master or the slave accessing one of the slave port registers. To clear the interrupt without affecting the register values, a dummy write can be made to SPSR.

### 19.3.6 Example ISR

A sample interrupt handler is shown below.

```
slave_isr::
    push af                ; save used registers

    ; read the data sent by the master
    ioi ld a, (SPD2R)
    ld (to_slv_d2), a
    ioi ld a, (SPD1R)
    ld (to_slv_d1), a
    ioi ld a, (SPD0R)
    ld (to_slv_d0), a

    ; if a response is required, perform it here
    ld a, (to_mas_d2)
    ioi ld (SPD2R), a
    ld a, (to_mas_d1)
    ioi ld (SPD1R), a
    ld a, (to_mas_d0)
    ioi ld (SPD0R), a    ; this write asserts /SLVATTN

    ; the interrupt request is cleared by any read/write of the registers

    pop af                ; restore used registers
    ipres
    ret
```

### 19.3.7 Other Configurations

There are other slave port configurations possible:

- The master could use the external I/O bus instead of the memory bus.
- All devices could poll the slave port status register to determine when data is present instead of relying on interrupts.
- The master could write to SPDOR, triggering an interrupt on the slave. The slave could then simply write a response into SPDOR, which the master detects by polling SPSR. This configuration is useful when fewer signals are desired, or the master device has no external interrupts available.

If polling is to be used, it is important to note that not all bits in the status register may be updated at once; it is possible to read a transitional value as the register updates. To guarantee a proper polling read, the status register should be read twice; when the same value is read both times the value is correct.

Similarly, it is possible to receive a scrambled value from a data register if it is read while being written. The protocol used should take account of this and prevent it from occurring (the protocol described above guarantees this will not occur).

### 19.3.8 Timing Diagrams

Figure 19-2 shows the sequence of events when the master reads/writes the slave port registers.

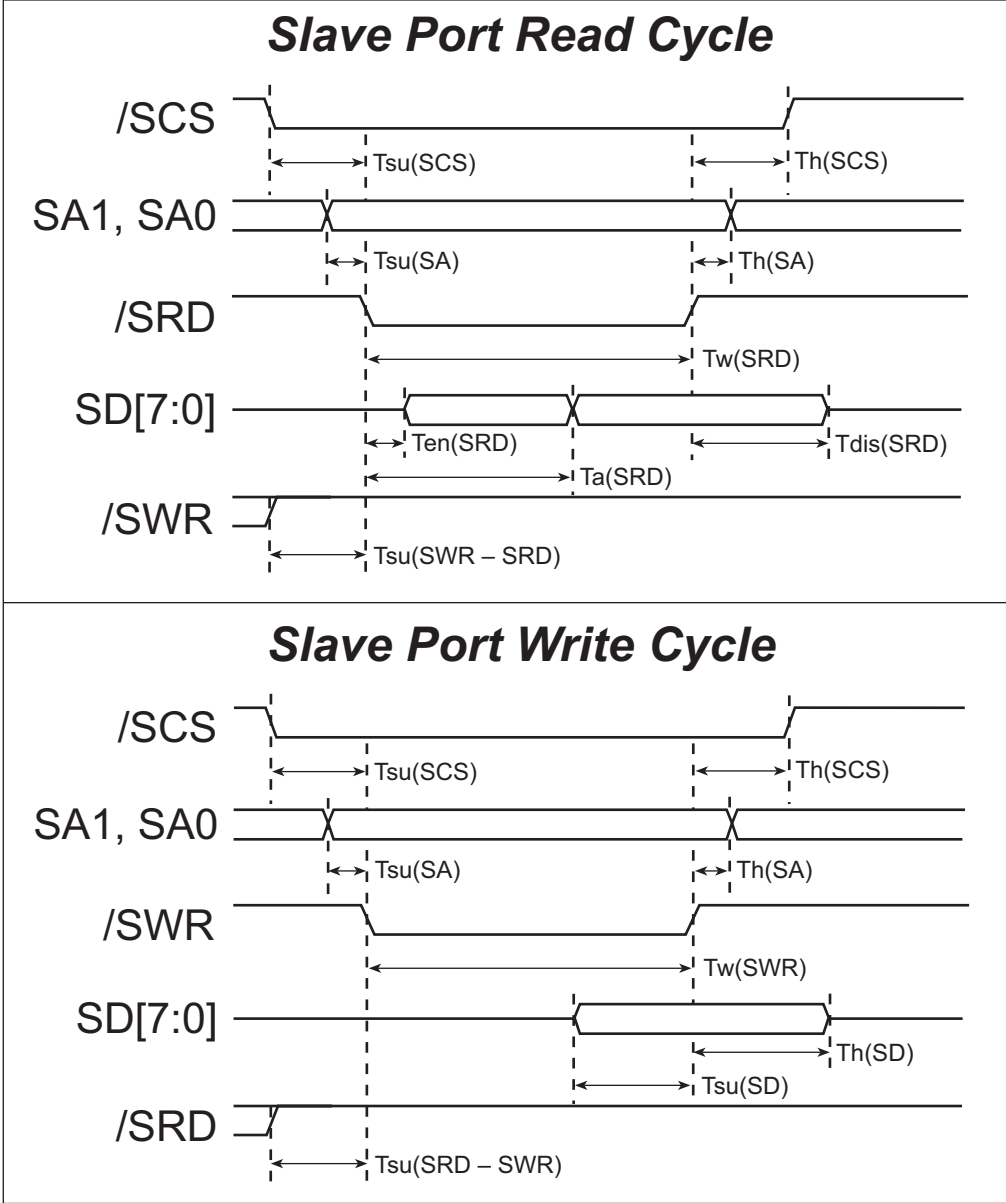

Figure 19-2. Slave Port R/W Timing Diagram



The following table explains the parameters used in Figure 19-2.

<b>Symbol</b>	<b>Parameter</b>	<b>Minimum (ns)</b>	<b>Maximum (ns)</b>
Tsu(SCS)	/SCS Setup Time	5	—
Th(SCS)	/SCS Hold Time	0	—
Tsu(SA)	SA Setup Time	5	—
Th(SA)	SA Hold Time	0	—
Tw(SRD)	/SRD Low Pulse Width	40	—
Ten(SRD)	/SRD to SD Enable Time	0	—
Ta(SRD)	/SRD to SD Access Time	—	30
Tdis(SRD)	/SRD to SD Disable Time	—	15
Tsu(SRW – SRD)	/SWR High to /SRD Low Setup Time	40	—
Tw(SWR)	/SWR Low Pulse Width	40	—
Tsu(SD)	SD Setup Time	10	—
Th(SD)	SD Hold Time	5	—
Tsu(SRD – SWR)	/SRD High to /SWR Low Setup Time	40	—

## 19.4 Register Descriptions

Slave Port Data x Registers		(SPD0R) (SPD1R) (SPD2R)	(Address = 0x0020) (Address = 0x0021) (Address = 0x0022)
Bit(s)	Value	Description	
7:0	Read	The corresponding byte of the slave port is read.	
	Write	The corresponding byte of the slave port is written.	

Slave Port Status Register		(SPSR)	(Address = 0x0023)
Bit(s)	Value	Description	
7	0	Processor wrote to SPSR.	
	1	Master wrote to Data Register 0.	
6	0	Slave port read byte 2 is empty.	
	1	Slave port read byte 2 is full.	
5	0	Slave port read byte 1 is empty.	
	1	Slave port read byte 1 is full.	
4	0	Slave port read byte 0 is empty.	
	1	Slave port read byte 0 is full.	
3	0	Master wrote to SPSR.	
	1	Processor wrote to SPD0R.	
2	0	Slave port write byte 2 is empty.	
	1	Slave port write byte 2 is full.	
1	0	Slave port write byte 1 is empty.	
	1	Slave port write byte 1 is full.	
0	0	Slave port write byte 0 is empty.	
	1	Slave port write byte 0 is full.	

<b>Slave Port Control Register (SPCR) (Address = 0x0024)</b>		
<b>Bit(s)</b>	<b>Value</b>	<b>Description</b>
7	0	Program fetch as a function of the SMODE pins.
	1	Ignore the SMODE pins program fetch function.
6:5	Read	These bits report the state of the SMODE pins.
	Write	These bits are ignored and should be written with zero.
4:2	000	Disable the slave port. Parallel Port A is a byte-wide input port.
	001	Disable the slave port. Parallel Port A is a byte-wide output port.
	010	Enable the slave port, with /SCS from Parallel Port E bit 7.
	011	Enable the external I/O bus. Parallel Port A is used for the data bus and Parallel Port B[7:2] is used for the address bus.
	100	This bit combination is reserved and should not be used.
	101	This bit combination is reserved and should not be used.
	110	Enable the slave port, with /SCS from Parallel Port B bit 6.
	111	Enable the external I/O bus. Parallel Port A is used for the data bus and Parallel Port B[7:0] is used for the address bus.
1:0	00	Slave port interrupts are disabled.
	01	Slave port interrupts use Interrupt Priority 1.
	10	Slave port interrupts use Interrupt Priority 2.
	11	Slave port interrupts use Interrupt Priority 3.



## 20. ANALOG COMPONENTS

### 20.1 Overview

The Rabbit 5000 has a 10-bit single-channel A/D converter, a 10-bit two-channel differential-input A/D converter, and a 10-bit two-channel differential-output D/A converter for 802.11 Wi-Fi operation. These analog features are available for customer use when Wi-Fi is not being used. Table 20-1 summarizes the analog features.

**Table 20-1. Analog Components**

Component Number	Function	Sampling Rate	Description	Pin(s)
0	A/D Converter	10 kilosamples/s to 50 megasamples/s	2 channels, 10-bit, differential Continuous Operation	VINIP + VININ VINQP + VINQN
1	D/A Converter	Up to 44 megasamples/s	2 channels, 10-bit, differential Continuous Operation	VOUTPI + VOUTNI VOUTPQ + VOUTNQ
2	A/D Converter	Up to 0.3 megasamples/s	1 channel, 10-bit, single-ended Convert on Signal	VIN8

The actual conversion rates depend on the clock sources used — each analog component can accept a clock from an external I/O pin or divide the peripheral clock by a value between 2 and 256.

Table 20-2 lists the detailed features for each analog component.

**Table 20-2. Analog Component Specifications**

Analog Component	Feature	Specification
0 (fast A/D converter)	Resolution	10 bits
	Input Range	2 V <sub>pp</sub> (differential)
	Operating Current Active Standby Power down	56 mA @ 1.8V, 20 mA @ 3.3V 2.5 mA @ 1.8 V 1 mA @ 1.8 V
	Transition Time Standby to active Power down to active	4 μs 1 ms
	Nonlinearity Differential (DNL) Integral (INL)	±0.5 LSB typ. ±1 LSB typ.
	Offset Error I to Q Offset Mismatch	±2% of full scale ±1% of full scale
	Gain Error I to Q Gain Mismatch	±5% of full scale ±1% of full scale
	Channel Isolation	60 dB typ.
1 (fast D/A converter)	Resolution	10 bits
	Input Range	2 V <sub>pp</sub> (differential)
	Allowed Common-Mode Voltage	0.9 V to 1.4 V
	Operating Current Active Standby Power down	22 mA @ 3.3 V < 1 mA @ 3.3 V < 1 μA @ 1.8 V
	Transition Time Standby to active Power down to active	2 μs 6 μs
	Offset Error I to Q Offset Mismatch	±2% of full scale ±1% of full scale
	Gain Error I to Q Gain Mismatch	±5% of full scale ±1% of full scale
	Channel Isolation	60 dB typ.

**Table 20-2. Analog Component Specifications (continued)**

Analog Component	Feature	Specification
2 (slow A/D converter)	Resolution	10 bits
	Input Range	0 V to 3.3 V
	Operating Current Active Standby	35 $\mu$ A @ 1.8 V, 62 $\mu$ A @ 3.3 V < 1 $\mu$ A @ 1.8 V, 3.3 V
	Transition Time Standby to active	15 $\mu$ s
	Nonlinearity Differential (DNL) Integral (INL)	$\pm 1$ LSB typ. $\pm 2$ LSB max.
	Offset Error	-1.5 to +2.5 LSB
	Gain Error	$\pm 2$ LSB max

## 20.2 Block Diagram

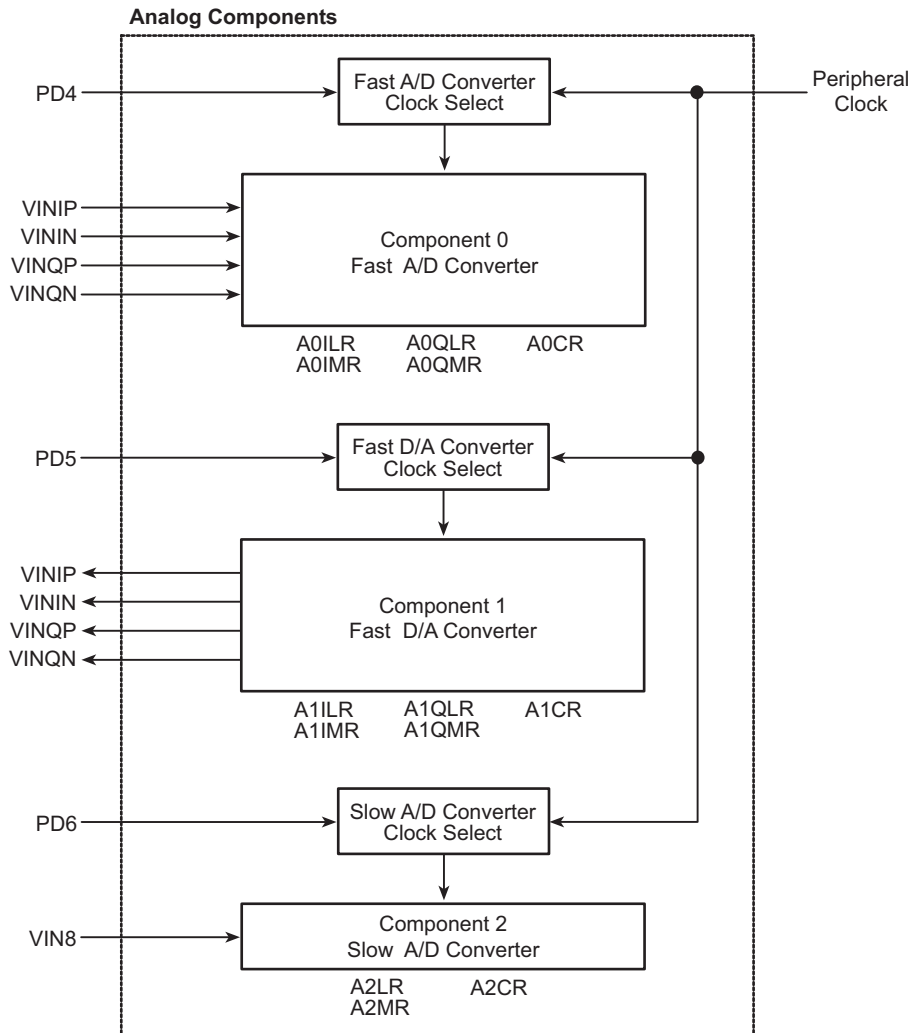



## 20.2.1 Registers

Register Name	Mnemonic	I/O Address	R/W	Reset
Analog Component 0 I LSB Register	A0ILR	0x0800	R/W	xxxxxxxx
Analog Component 0 I MSB Register	A0IMR	0x0801	R/W	xxxxxxxx
Analog Component 0 Q LSB Register	A0QLR	0x0802	R/W	xxxxxxxx
Analog Component 0 Q MSB Register	A0QMR	0x0803	R/W	xxxxxxxx
Analog Component 0 Control Register	A0CR	0x0804	R/W	00000000
Analog Component 1 I LSB Register	A1ILR	0x0810	R/W	xxxxxxxx
Analog Component 1 I MSB Register	A1IMR	0x0811	R/W	xxxxxxxx
Analog Component 1 Q LSB Register	A1QLR	0x0812	R/W	xxxxxxxx
Analog Component 1 Q MSB Register	A1QMR	0x0813	R/W	xxxxxxxx
Analog Component 1 Control Register	A1CR	0x0814	R/W	00000000
Analog Component 2 LSB Register	A2LR	0x0820	R/W	xxxxxxxx
Analog Component 2 MSB Register	A2MR	0x0821	R/W	xxxxxxxx
Analog Component 2 Control Register	A2CR	0x0824	R/W	00000000

## 20.3 Dependencies

### 20.3.1 I/O Pins

The fast A/D converter accepts differential input on the pin pairs VININ/VINIP and VINQN/VINQP. The VREFP, VREFN, ADVCM, and ADVBG pins should be connected as shown in the sample circuit diagrams. The IBIAS pin should remain unconnected.

The fast D/A converter provides differential output on the pin pairs VOUTNI/VOUTPI and VOUTNQ/VOUTPQ. The DAVCM pin should be used to provide the common-mode voltage, which can range from 0.9 V to 1.4 V; see the sample circuit diagram for an example. DAVBG should be connected as shown in the sample circuit diagram.

The slow ADC accepts a single input on the VIN8 pin.

The PD4, PD5, and PD6 pins can be used instead of the peripheral clock as clock inputs for analog component 0, 1, or 2 respectively.

### 20.3.2 Clocks

Each of the analog components can be clocked by the peripheral clock divided by 2, 4, 8, 16, 32, 64, 128, or 256, or by a clock input on PD4, PD5, or PD6, depending on the component. Exercise care when selecting the clock to keep the data rate below the maximum sample rate of the component you are configuring.

## 20.4 Operation

### 20.4.1 Fast A/D Converter

The following steps must be taken to operate the fast A/D converter.

1. Select the clock source and enable the fast A/D converter by writing to A0CR.
2. Read the channel data in the A0IxR and A0QxR registers. Reading the least-significant bit registers first will lock the value in the most-significant bit register until it is read.
3. For faster update, an 8-bit value can be obtained by only reading the most-significant bit registers (A0IMR or A0QMR).
4. To reduce power consumption, the fast A/D converter can be put into a standby or sleep mode by writing to A0CR.

### 20.4.2 Fast D/A Converter

The following steps must be taken to operate the fast D/A converter.

1. Select the clock source and enable the fast D/A converter by writing to A1CR.
2. Write the channel data to the A1IxR and A1QxR registers. Writing the least-significant bit registers first will hold the conversion output until the most-significant bit register is written.
3. For faster update, an 8-bit value can be output by only writing the most-significant bit registers (A1IMR or A1QMR).
4. To reduce power consumption, the fast D/A converter can be put into a standby or power-down mode by writing to A1CR.

### 20.4.3 Slow A/D Converter

The following steps must be taken to operate the slow A/D converter.

1. Select the clock source and enable the slow A/D converter by writing to A2CR.
2. Start a conversion by writing to bit 2 of A2CR.
3. Monitor bit 3 of A2CR to determine when the conversion is complete, then read the data in the A2LR and A2MR registers. Reading the least-significant bit registers first will lock the value in the most-significant bit register until it is read.
4. For faster update, an 8-bit value can be obtained by only reading A2MR.
5. To reduce power consumption, the slow A/D converter can be put into a sleep mode by writing to A2CR.

## 20.5 Sample Circuits

Sample circuits are shown below for the analog components. Since each analog component has dedicated power and ground, be sure to allow enough filtering for each block as shown — a range of ferrite beads may be used — we obtained good results with ferrite beads rated at  $120\ \Omega$  at  $100\ \text{MHz}$ .

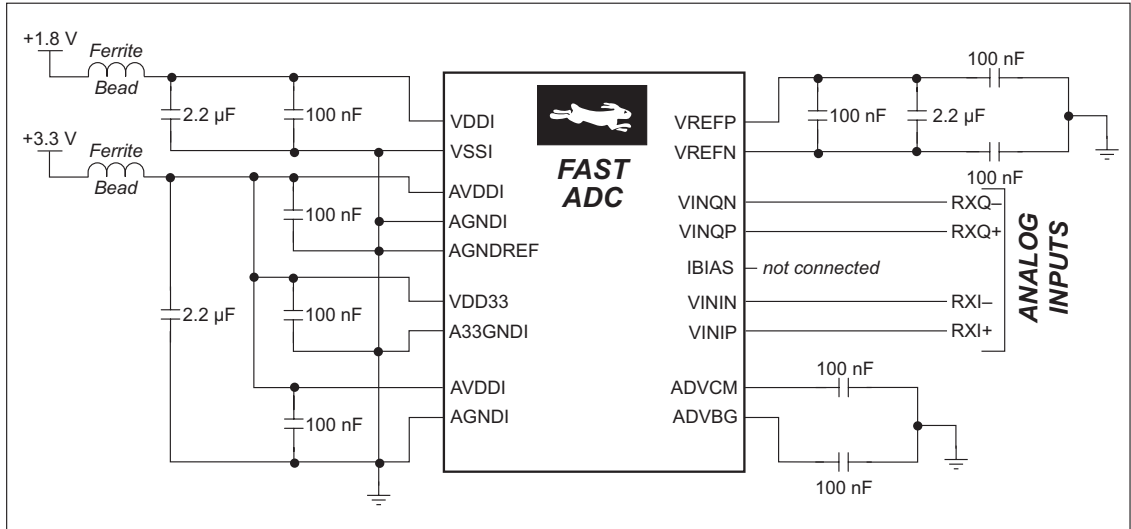

Figure 20-1. Sample Fast A/D Converter Circuit

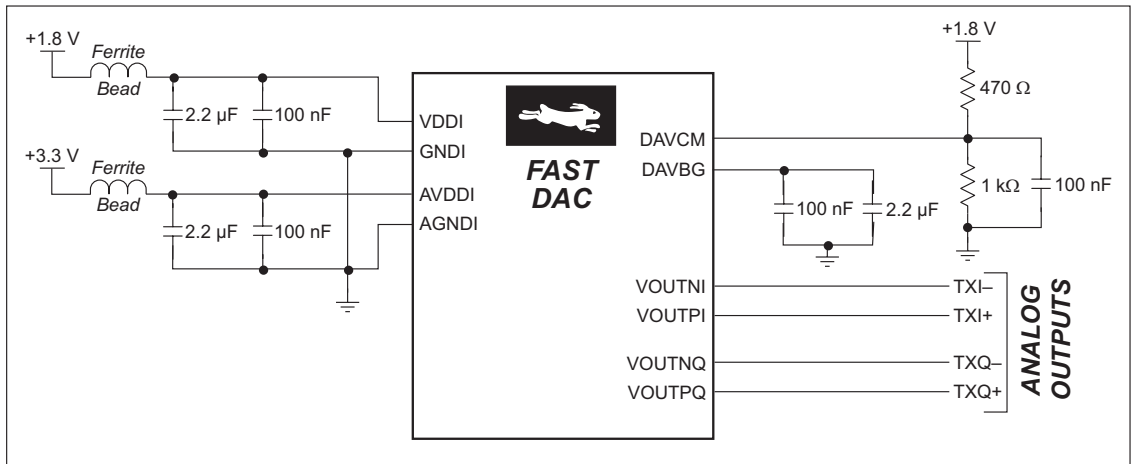
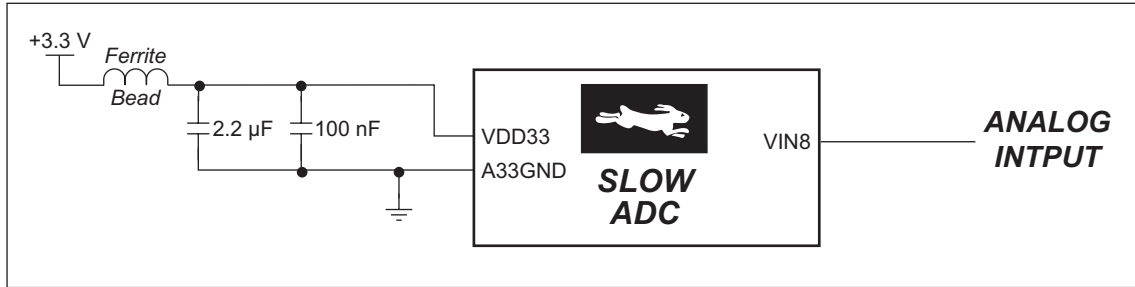

Figure 20-2. Sample Fast D/A Converter Circuit



**Figure 20-3. Sample Slow A/D Converter Circuit**

## 20.6 Register Descriptions

Analog Component 0 I LSB Register Analog Component 0 Q LSB Register		(A0ILR) (A0QLR)	(Address = 0x0800) (Address = 0x0802)
Bit(s)	Value	Description	
7:6	Read	The current value of the two least-significant bits of the fast A/D converter are returned. Reading this register locks the value in the corresponding MSB register to guarantee that the full 10 bits are valid.	
	Write	Writes to these bits are ignored.	
5:0		These bits are ignored and will always return zeros when read.	

Analog Component 0 I MSB Register Analog Component 0 Q MSB Register		(A0IMR) (A0QMR)	(Address = 0x0801) (Address = 0x0803)
Bit(s)	Value	Description	
7:0	Read	The current value of the eight most-significant bits of the fast A/D converter are returned.	
	Write	Writes to this register are ignored.	

<b>Analog Component 0 Control Register (A0CR) (Address = 0x0804)</b>		
<b>Bit(s)</b>	<b>Value</b>	<b>Description</b>
7	0	Use peripheral clock as fast A/D converter clock source.
	1	Use Parallel Port PD4 as fast A/D converter clock source.
6:4	000	Clock divided by 2.
	001	Clock divided by 4.
	010	Clock divided by 8.
	011	Clock divided by 16.
	100	Clock divided by 32.
	101	Clock divided by 64.
	110	Clock divided by 128.
	111	Clock divided by 256.
3	0	Disable fast A/D converter Q channel.
	1	Enable fast A/D converter Q channel.
2	0	Disable fast A/D converter I channel.
	1	Enable fast A/D converter I channel.
1:0	00	Fast A/D converter powered down.
	01	Fast A/D converter in sleep mode.
	10	Fast A/D converter active, outputting unsigned binary.
	11	Fast A/D converter active, outputting two's complement.

<b>Analog Component 1 I LSB Register (A1ILR) (Address = 0x0810)</b>		
<b>Analog Component 1 Q LSB Register (A1QLR) (Address = 0x0812)</b>		
<b>Bit(s)</b>	<b>Value</b>	<b>Description</b>
7:6	Write	The two least-significant bits for the fast D/A converter are stored. These bits will not be transferred to the fast D/A converter until the corresponding MSB register is written to guarantee that the full 10 bits are valid.
	Read	These bits always return zeros when read.
5:0		These bits are ignored and will always return zeros when read.

<b>Analog Component 1 I MSB Register</b>		<b>(A1IMR)</b>	<b>(Address = 0x0811)</b>
<b>Analog Component 1 Q MSB Register</b>		<b>(A1QMR)</b>	<b>(Address = 0x0813)</b>
<b>Bit(s)</b>	<b>Value</b>	<b>Description</b>	
7:0	Write	The eight most-significant bits for the fast D/A converter are stored. Writing these bits transfers the entire 10 bits to the fast D/A converter.	
	Read	These bits always return zeros when read.	

<b>Analog Component 1 Control Register</b>		<b>(A1CR)</b>	<b>(Address = 0x0814)</b>
<b>Bit(s)</b>	<b>Value</b>	<b>Description</b>	
7	0	Use peripheral clock as fast D/A converter clock source.	
	1	Use Parallel Port PD5 as fast D/A converter clock source.	
6:4	000	Clock divided by 2.	
	001	Clock divided by 4.	
	010	Clock divided by 8.	
	011	Clock divided by 16.	
	100	Clock divided by 32.	
	101	Clock divided by 64.	
	110	Clock divided by 128.	
	111	Clock divided by 256.	
3	0	Disable fast D/A converter Q channel.	
	1	Enable fast D/A converter Q channel.	
2	0	Disable fast D/A converter I channel.	
	1	Enable fast D/A converter I channel.	
1		This bit is reserved and should be written with zero.	
0	0	Fast D/A converter in normal mode (powered down if both channels are disabled).	
	1	Fast D/A converter in sleep mode.	

<b>Analog Component 2 LSB Register (A2LR) (Address = 0x0820)</b>		
<b>Bit(s)</b>	<b>Value</b>	<b>Description</b>
7:6	Read	The current value of the two least-significant bits of the slow A/D converter are returned. Reading this register locks the value in the corresponding MSB register to guarantee that the full 10 bits are valid.
	Write	Writes to this register are ignored.
5:0		These bits are ignored and will always return zeros when read.

<b>Analog Component 2 MSB Register (A2MR) (Address = 0x0821)</b>		
<b>Bit(s)</b>	<b>Value</b>	<b>Description</b>
7:0	Read	The current value of the eight most-significant bits of the slow A/D converter are returned.
	Write	Writes to this register are ignored.



<b>Analog Component 2 Control Register (A2CR) (Address = 0x0824)</b>		
<b>Bit(s)</b>	<b>Value</b>	<b>Description</b>
7	0	Use peripheral clock as slow A/D converter clock source.
	1	Use Parallel Port PD6 as slow A/D converter clock source.
6:4	000	Clock divided by 2.
	001	Clock divided by 4.
	010	Clock divided by 8.
	011	Clock divided by 16.
	100	Clock divided by 32.
	101	Clock divided by 64.
	110	Clock divided by 128.
	111	Clock divided by 256.
3 (Read-only)	0	Conversion not complete.
	1	Conversion complete.
2 (Write-only)	0	No effect on slow A/D converter.
	1	Start conversion.
1		These bits are reserved. Reads return zeros.
0	0	Slow A/D converter in sleep mode. This bit is ignored if Network Port C is enabled.
	1	Slow A/D converter active.



# 21. DMA CHANNELS

## 21.1 Overview

There are eight independent DMA channels on the Rabbit 5000. All eight channels are identical, and are capable of transferring data to or from memory, external I/O, or internal I/O. The priority between the channels can be either fixed or rotating, and the DMA use of the bus can be limited to guarantee interrupt latency or CPU throughput. The DMA channels are capable of special handling for the last byte of data when sending data to selected internal I/O addresses (such as the HDLC serial ports or to the Ethernet peripheral), and can also transfer end-of-frame status after transferring data from selected internal I/O addresses.

The DMA channels can watch the data being transferred, and can terminate a transfer when a particular byte is matched. A mask is available for the byte match to allow termination only on particular bit settings in the data instead of an exact byte match.

Memory-to-memory transfers proceed at the maximum transfer rate unless they are gated by an external request signal or the internal timed request. Transfers to or from a number of internal I/O addresses are controlled by transfer request signals. These transfer request signals are connected automatically as a function of the internal I/O address loaded into the DMA channel. Note that if both the source and the destination are internal I/O, the source transfer request is used by the DMA channel.

The DMA channels are inherently byte-oriented, so while DMA transfers can be done from a 16-bit memory, DMA transfers to a 16-bit memory can only be done if the 16-bit memory is set up to allow byte writes (see Chapter 5 for more information). For memory to memory transfers, a word transfer will occur if both addresses are aligned, but byte writes must still be enabled on the destination memory. The Ethernet and Wi-Fi peripherals are special cases as well — when the 16-bit bus is enabled and the DMA source or destination address is a network port register, the DMA will attempt to transfer words if the memory address is aligned.

There are two inputs available for requests linked to external I/O devices. These two external requests may be assigned to any DMA channel. These requests may also be used by a channel that has an internal I/O as a destination. In this case, the external request acts as a “flow control” signal for the DMA transfers because the external request is “ANDed” with the automatically connected internal request.

To facilitate periodic DMA transfers, there is also an internal *timed request*. This request is generated from a programmable 16-bit counter and may be assigned to any DMA channel. As in the case of the external requests, this request is “ANDed” with any internal or external request that is also assigned to that DMA channel. This periodic request can be programmed to transfer one byte or an entire buffer. The single-byte option is useful for driving an output port to create a sampled waveform, while the entire-buffer option can be used, for example, to send precisely timed serial messages over a serial port.

The DMA operation is controlled by memory structures called buffer descriptors. The current buffer descriptor resides in the registers of the DMA channel, but may have been either placed there by the processor or loaded directly by the DMA channel itself. Buffer descriptors may be used singly to transfer one block of data, or they may be linked together for “scatter-gather” operation. Each DMA channel also contains an “initial address” that points to the first buffer descriptor in memory and allows the DMA channel to rewind itself automatically in the case of a transmit retry by the network port. Each buffer descriptor contains a pair of control bytes, a byte count for the data, a source address, a destination address, and an optional link address. In addition, each DMA channel retains a count of the number of bytes remaining in the buffer to allow software to determine the amount of valid data in a buffer that are terminated early by the source of the data.

A buffer descriptor in memory consists of either 12 or 16 consecutive bytes organized as shown in Table 21-1. The DMA channel uses the information in the control byte to determine the length of the buffer descriptor as well as which information to fetch from the buffer descriptor. If no link address field is present, the buffer descriptor is only 12 bytes long. A memory address for either source or destination causes the DMA channel to fetch three bytes from the corresponding field in the buffer descriptor. An internal I/O or external I/O address for either source or destination causes the DMA channel to fetch two bytes from the corresponding field in the buffer descriptor.

DMA memory addresses are always physical addresses, and are never translated by the MMU. All DMA memory addresses use the memory control signals, wait states, and flipped bits as selected in the Master Memory Bank Control registers. All DMA external I/O addresses use the I/O control signals and wait states as selected in the external I/O registers.

The first byte in the first buffer descriptor (the byte pointed to by the initial address) is reserved for status information when transferring data from an internal serial or network device. This automatic status transfer means that the processor does not need to service any interrupts from a serial or network receiver except in the case of an error condition.

When transferring data to an internal HDLC serial or Ethernet transmitter, the last byte of the last buffer will be written automatically to a special destination address to tag the data as the last in the frame, without processor intervention. However, this function is not available in the case where the buffer contains only one byte of data. If this case should occur, the buffer descriptor must contain the special destination address.

All the DMA channels request interrupts at the same priority level, which is set by a field in the DMA Master Control Register, but each DMA channel has its own interrupt vector location. This speeds up interrupt processing for the DMA interrupts by eliminating the need to resolve which DMA channel is actually requesting an interrupt.

DMA transfers may be programmed to occur at any priority level. If the programmed level is greater than or equal to the current CPU operating level, DMA transfers will occur on demand. When the CPU operating level is greater than the programmed DMA operating level, no DMA transfers can occur. This allows interrupt services routines, or other critical code, to run with a guarantee that there will be no DMA activity during execution. Note that a simultaneous interrupt request and DMA transfer request will be resolved in favor of the DMA transfer request.

Normally all DMA transfers are flow-through, meaning that the DMA does separate read and write transactions to transfer the data. However, the Rabbit 5000 DMA also contains dedicated buses to support fly-by transactions to and from certain internal I/O addresses. A fly-by transfer looks like a single transaction on the internal and external bus, where data are transferred directly to/from the peripheral from/to a memory device. Only the network ports support fly-by transfers, and the DMA automatically recognizes internal I/O addresses that support fly-by transfers.

## 21.1.1 Block Diagram

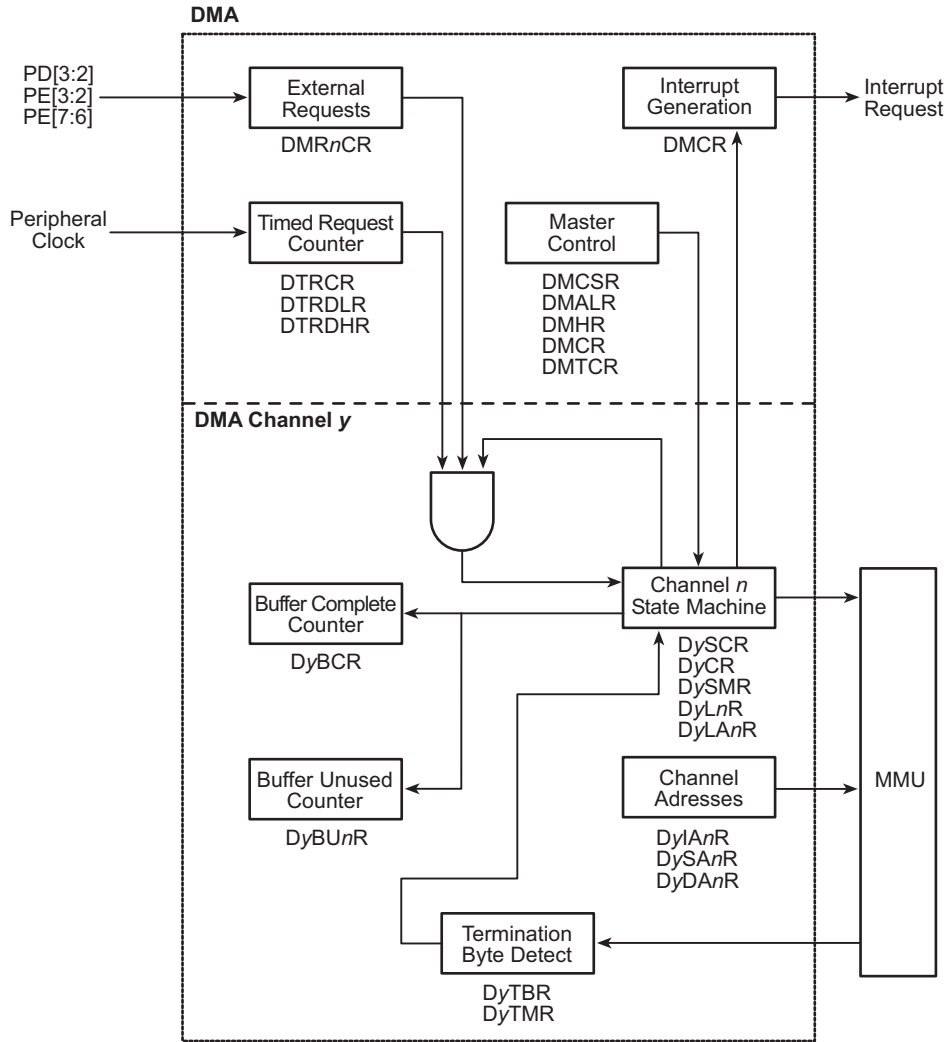

## 21.1.2 Registers

Register Name	Mnemonic	I/O Address	R/W	Reset
DMA Master Control/Status Register	DMCSR	0x0100	R/W	00000000
DMA Master Auto-Load Register	DMALR	0x0101	W	00000000
DMA Master Halt Register	DMHR	0x0102	W	00000000
DMA y Buffer Complete Register	DyBCR	0x01y3	R	00000000
DMA Master Control Register	DMCR	0x0104	R/W	00000000
DMA Master Timing Control Register	DMTCR	0x0105	R/W	00000000
DMA Master Request 0 Control Register	DMR0CR	0x0106	R/W	00000000
DMA Master Request 0 Control Register	DMR1CR	0x0107	R/W	00000000
DMA Timed Request Control Register	DTRCR	0x0115	R/W	00000000
DMA Timed Request Divider Low Register	DTRDLR	0x0116	R/W	xxxxxxx
DMA Timed Request Divider High Register	DTRDHR	0x0117	R/W	xxxxxxx
DMA y Termination Byte Register	DyTBR	0x01y8	R/W	xxxxxxx
DMA y Termination Mask Register	DyTMR	0x01y9	R/W	00000000
DMA y Buffer Unused [7:0] Register	DyBU0R	0x01yA	R	00000000
DMA y Buffer Unused [15:8] Register	DyBU1R	0x01yB	R	00000000
DMA y Initial Address [7:0] Register	DyIA0R	0x01yC	R/W	xxxxxxx
DMA y Initial Address [15:8] Register	DyIA1R	0x01yD	R/W	xxxxxxx
DMA y Initial Address [23:16] Register	DyIA2R	0x01yE	R/W	xxxxxxx
DMA y Special Control Register	DySCR	0x01z0 (z = y + 8)	R/W	00000000
DMA y Control Register	DyCR	0x01z1 (z = y + 8)	R/W	00000000
DMA y Buffer Length [7:0] Register	DyL0R	0x01z2 (z = y + 8)	R/W	xxxxxxx
DMA y Buffer Length [15:8] Register	DyL1R	0x01z3 (z = y + 8)	R/W	xxxxxxx
DMA y Source Address [7:0] Register	DySA0R	0x01z4 (z = y + 8)	W	xxxxxxx
DMA y Source Address [15:8] Register	DySA1R	0x01z5 (z = y + 8)	W	xxxxxxx
DMA y Source Address [23:16] Register	DySA2R	0x01z6 (z = y + 8)	W	xxxxxxx
DMA y Destination Address [7:0] Register	DyDA0R	0x01z8 (z = y + 8)	W	xxxxxxx
DMA y Destination Address [15:8] Register	DyDA1R	0x01z9 (z = y + 8)	W	xxxxxxx
DMA y Destination Address [23:16] Register	DyDA2R	0x01zA (z = y + 8)	W	xxxxxxx
DMA y Link Address [7:0] Register	DyLA0R	0x01zC (z = y + 8)	R/W	xxxxxxx
DMA y Link Address [15:8] Register	DyLA1R	0x01zD (z = y + 8)	R/W	xxxxxxx
DMA y Link Address [23:16] Register	DyLA2R	0x01zE (z = y + 8)	R/W	xxxxxxx

**NOTE:** The y in “DMA y ...” expresses the DMA channel number (0–7).

## **21.2 Dependencies**

### **21.2.1 I/O Pins**

External DMA Request 0 can be enabled from pins PD2, PE2, or PE6. External DMA Request 1 can be enabled from pins PD3, PE3, or PE7.

The DMA can use either the memory management unit or the external I/O bus to perform its transfers, and so will use the appropriate pins for each operation.

### **21.2.2 Clocks**

The DMA peripheral uses the peripheral clock for all operations. If the timed request option is enabled, then the 16-bit timed request counter will be clocked by the peripheral clock and will provide a DMA request each time it counts down to zero.

### **21.2.3 Interrupts**

Each DMA channel has its own dedicated interrupt that can occur at the end of any DMA transfer, as specified in DyCR (normally loaded from the buffer descriptor). The interrupt request is automatically cleared when the interrupt is handled.

The DMA interrupt vectors are in the EIR starting at offset 0x080 for DMA Channel 0 and ending at offset 0x0F0 for DMA Channel 7. They can be set as Priority 1, 2, or 3.



## 21.3 Operation

It is possible to set up and start a DMA operation by writing directly to all the relevant address, length, and control registers, but it is expected that the typical operation would be to create a buffer descriptor in memory, write the address of that descriptor to the initial address registers (DyIAnR), and use a write to DMALR to auto-load the values from memory into the registers and start the transfer. The DMA transfer will then continue reading buffer descriptors until a buffer-marked halt is completed.

The descriptor can be either 12 or 16 bytes in length; a bit in the channel control byte (which corresponds to DyCR) selects whether the link address is present or not. The processor skips the read of those bytes if a 12-byte descriptor is selected, and always skips the reads of the bytes marked “not used.”

**Table 21-1. DMA Buffer Descriptor**

	Byte 0	Byte 1	Byte 2	Byte 3
Bytes 0–3	Special Channel Control / Frame Status	Channel Control	Buffer Length [15:0]	
Bytes 4–7	Source Address [23:0]			Not Used
Bytes 8–11	Destination Address [23:0]			Not Used
Bytes 12–15	Link Address [23:0]			Not Used

It is possible to abort a DMA transfer by writing the appropriate bit to the halt register, DMHR. It is also possible to restart a DMA transfer using the already-loaded register values by writing to DMCSR.

The following steps explain how to set up a DMA channel.

1. Select the DMA transfer and interrupt priorities by writing to DMCR.
2. Select the DMA channel priority, maximum bytes per burst, and minimum clocks between bursts by writing to DMTCR.
3. Write the interrupt vector for the interrupt service routine to the external interrupt table.
4. Enable an external request line by writing to DMR0CR or DMR1CR. Make sure that the pin selected is set up as an input. Note that this enable will be logical-ANDed to any internal DMA enables if the DMA transfer is to/from an internal peripheral.
5. Enable the internal-timed transfer request by writing to DTRCR. Select the divider value by writing to DTRDLR and DTRDHR. Note that this enable will be logical-ANDed to any internal DMA enables if the DMA transfer is to/from an internal peripheral.
6. Select a byte to terminate the transfer on by writing to the appropriate DyTBR and DyTMR registers.

7. The desired control, length, and address registers should be written to a buffer descriptor (or descriptors) in memory if not done already. Several automatic options (auto-increment, auto-decrement, special peripheral enables) can be overridden by settings in DySCR.
8. The initial address registers (DyIANR) should be loaded with the physical address of the first buffer descriptor.
9. The buffer descriptor can be loaded and the DMA transfer started by writing to the appropriate bit of DMALR.

### 21.3.1 Handling Interrupts

The DMA interrupt request is cleared automatically when the interrupt is handled. A DMA interrupt will occur at the end of a transfer for any buffer descriptor that has bit 4 of DyCR set.

### 21.3.2 Example ISR

A sample interrupt handler is shown below.

```

dma_isr::
    push af

    ; do something with the data in the current buffer
    ; the interrupt request is automatically cleared

    pop af
    ipres
    ret

```

### 21.3.3 DMA Priority with the Processor

Since the Rabbit 5000 DMA uses the memory management unit to perform transfers, normal code execution cannot occur while the DMA is active. This includes handling interrupts, so it is important to limit the amount of time that the DMA can operate.

This is handled in several ways. First of all, the DMA transfers can be set to take place whenever the processor is operating at one of the four priority levels, 0–3 (note that there is a single priority level for all DMA transfers).

**Table 21-2. DMA Transfer Priority**

DMA Transfers at	Operation
Priority 0	DMA transfers only allowed when processor priority at 0
Priority 1	DMA transfers only allowed when processor priority at 0 or 1
Priority 2	DMA transfers only allowed when processor priority at 0, 1, or 2
Priority 3	DMA transfers allowed at any time

Setting an interrupt priority to something greater than the DMA transfer priority will ensure that no DMA activity occurs during that interrupt handler. Note that when both an interrupt and a DMA transfer are pending, the DMA transfer will be selected for execution first (provided its priority is equal or greater than the current processor priority level).

When a DMA transfer is occurring, normal code execution will not occur until the transfer is completed. To prevent DMA transfers from excessively blocking interrupts or otherwise interfering with normal code execution, two options can be set in DMTCR. First, the maximum limit of a DMA transfer can be set from 1 to 64 bytes, which sets an upper limit on interrupt latency arising from a DMA transfer. Second, the minimum number of clocks before the DMA can be active again can be set from 12 to 512 clocks, guaranteeing processing time for the application.

The values providing roughly equal access to the memory bus for both the processor and the DMA is eight bytes per burst and 64 clocks between bursts.

When starting up, the DMA requires several cycles of overhead. This overhead comes about because the DMA actually uses part of the processor to perform the data transfers, and consists of one instruction fetch time plus three clock cycles. The byte fetched during the instruction fetch time is discarded, and will be refetched at the completion of the DMA burst. At the end of the DMA burst, two clock cycles are required before this first instruction fetch starts. An individual DMA channel transfers data without any overhead between bytes, but there is always one clock cycle of dead time when switching between DMA channels. Table 21-3 shows the effective number of clock cycles required per burst, assuming a single DMA channel transfer, 8-bit memory, and no wait states. Access via 16-bit memory would provide up to twice the throughput, depending on address alignment.

**Table 21-3. Maximum DMA Transfer Rates**

Setting	Total Clocks	Clocks per Byte Transferred
1 byte per burst	11 clocks	11
2 bytes per burst	15 clocks	7.5
3 bytes per burst	19 clocks	6.3
4 bytes per burst	23 clocks	5.8
8 bytes per burst	39 clocks	4.9
16 bytes per burst	71 clocks	4.4
32 bytes per burst	135 clocks	4.2
64 bytes per burst	263 clocks	4.1

The total number of clocks listed in Table 21-3 is related to the number of bytes per burst by the following formula.

$$\text{Total Clocks} = 4 \times \text{Number of Bytes per Burst} + 7 \text{ (for overhead)}$$

### 21.3.4 DMA Channel Priority

It is possible to control the priority between separate DMA channels. There are three channel-priority options in the Rabbit 5000. The first is fixed priority after every byte where the priority of each channel is equal to its number, i.e., if both DMA Channels 3 and 4 have a pending transfer request, DMA Channel 4 will always be enabled first. If at any point a channel with higher priority than the one currently transferring has a DMA request pending, the current transfer will be terminated and the new channel's transfer will start. With this setting, DMA Channel 7 will always have priority over all other channels, and DMA Channel 0 will transfer only if no other channels have pending requests.

The other two settings rotate the priority between channels as shown in Table 21-4; after the seventh rotation, the priority sequence restarts at the top of the table. One option is to rotate priority after every byte analogous to the fixed-priority setting. The priority list is updated after each byte transferred, and if a higher priority channel has a pending request, the current transfer will be terminated and the new channel transfer will start. The other option is to rotate after every burst; this will guarantee that reasonable amounts of data are transferred by each channel before a switchover occurs.

**Table 21-4. Rotating DMA Channel Priority**

Rotation	Channel Priority, High to Low
Initial (and eighth)	7, 6, 5, 4, 3, 2, 1, 0
First	6, 5, 4, 3, 2, 1, 0, 7
Second	5, 4, 3, 2, 1, 0, 7, 6
Third	4, 3, 2, 1, 0, 7, 6, 5
Fourth	3, 2, 1, 0, 7, 6, 5, 4
Fifth	2, 1, 0, 7, 6, 5, 4, 3
Sixth	1, 0, 7, 6, 5, 4, 3, 2
Seventh	0, 7, 6, 5, 4, 3, 2, 1

### 21.3.5 Buffer Descriptor Modes

Flags in the control byte of a buffer descriptor (which gets loaded into DyCR) describe whether to halt on completion of the transfer (or load another descriptor) and whether the next descriptor is adjacent in memory (which implies that the current descriptor is only 12 bytes long) or located at the link address. Each descriptor can also be set to generate an interrupt on completion of the transfer. By using these options in various ways, the Rabbit 5000 DMA can be operated in a number of conventional DMA modes.

The most common options are described here; others are certainly possible by different use of the available linking methods.

### 21.3.5.1 Single Buffer

In the simplest mode, a single descriptor is set to halt and interrupt on completion.

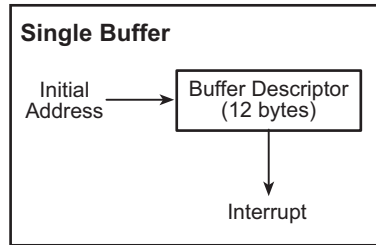

### 21.3.5.2 Buffer Array

In this mode, an array of 12-byte descriptors is set up adjacent in memory; only the last buffer is set to halt on completion. The last buffer is also typically set to interrupt on completion, but other buffer descriptors in the array can also generate interrupts.

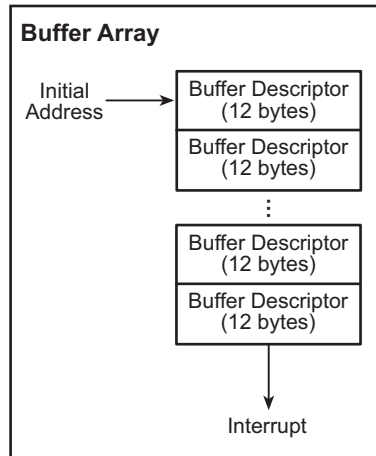

The advantage of the buffer array is that its descriptors require less memory than a full 16-byte descriptor.

The simplest version of the buffer array is a double buffer, which is frequently used to provide a reserve buffer in case the application is slow in handling the first buffer once received (in this case, both buffers are enabled to interrupt on completion).

### 21.3.5.3 Linked List

A linked list is similar to a buffer array, except that 16-byte descriptors are used and the descriptors are not necessarily adjacent in memory. The advantage of this mode is the ability to spread descriptors.

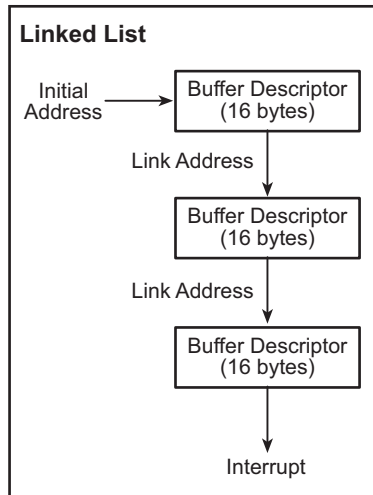

#### 21.3.5.4 Circular Queue

A circular queue is a buffer array or linked list where the final buffer is linked back to the first buffer in the sequence. This method allows for continuous reception of transfers without having to reload the initial address for the DMA buffer descriptor sequence.

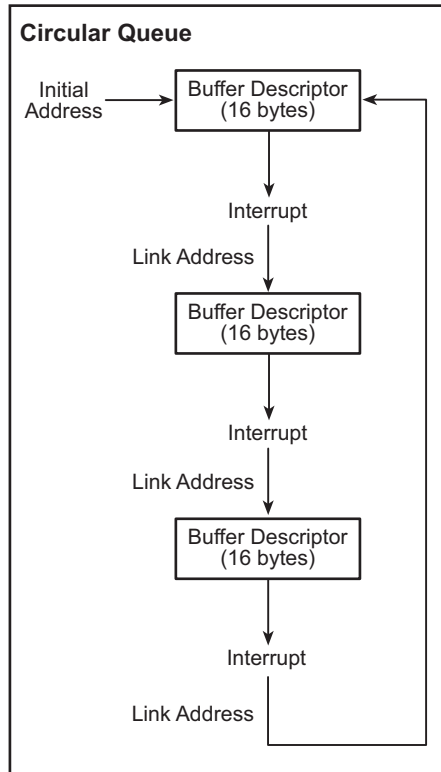

The “ping-pong buffer,” where there are only two buffers, is the simplest version of a circular queue. The application can operate on one buffer while the other buffer is being loaded.

#### 21.3.5.5 Linked Array

The linked array is simply a linked list of buffer arrays, where the last buffer in each array is linked to the first buffer in the next array (which can be located anywhere in memory). This method could be useful where a message is broken down into separate transfers, but entire messages could be scattered/gathered from anywhere in memory.

### **21.3.6 DMA with Peripherals**

When the DMA is directed towards an internal I/O address, the DMA transfer request signals will be connected as appropriate for that peripheral. For example, when a DMA transfer is performed to Serial Port D's data register, the transfer request will be enabled whenever the serial port transmit buffer is empty, and will be disabled whenever it is not.

#### **21.3.6.1 DMA with HDLC Serial Ports**

The HDLC serial ports receive special handling by the DMA. When the DMA destination is Serial Port E's or Serial Port F's data register (SxDR), the final byte of the transfer will be written to the appropriate last data register (SxLDR) as required to complete an HDLC packet and append the CRC value. In addition, the value in the appropriate status register (SxSR) will be written to the status byte in the buffer descriptor pointed to by the initial address registers (not necessarily the buffer descriptor that is currently being used). These features allow an application to automatically send and receive packets via DMA, only requiring direct handling of a packet when an error occurs.

#### **21.3.6.2 DMA with Ethernet**

The Ethernet network peripheral also receives special handling by the DMA. When the DMA destination is the network data register (NBDR), the final byte of the transfer will be written to the last data register (NBLDR) as required to complete an Ethernet packet and append the CRC value. The Ethernet network peripheral also has support for DMA fly-by transfers between the peripheral and external memory.

#### **21.3.6.3 DMA with Wi-Fi**

The Wi-Fi network peripheral has support for DMA fly-by transfers between the peripheral and external memory. However, the Wi-Fi peripheral has a minimum access time of 75 ns, and typically requires wait states, so fly-by DMA may not be the most efficient access method.

#### **21.3.6.4 DMA with PWM and Timer C**

The PWM and Timer C peripherals have special support for DMA — the block access and pointer registers in each of these peripherals provide a means for the DMA to update the settings of these peripherals at some desired rate. This allows complex PWM waveforms to be generated by using the DMA timed request to update the PWM duty cycles at regular intervals.



## 21.4 Register Descriptions

<b>DMA Master Control/Status Register (DMCSR) (Address = 0x0100)</b>		
<b>Bit(s)</b>	<b>Value</b>	<b>Description</b>
7:0  (Write-only)	0	No effect on the corresponding DMA channel.
	1	Start (or restart) the corresponding DMA channel using the contents of the DMA channel registers. This command should only be issued after all the DMA channel registers (source, destination, length, and link if applicable) have been loaded.
7:0  (Read-only)	0	The corresponding DMA channel is either disabled or has completed the last buffer descriptor.
	1	The corresponding DMA channel is enabled and active. These bits are set by the start command and remain set until the completion of the last buffer.

<b>DMA Master Auto-Load Register (DMALR) (Address = 0x0101)</b>		
<b>Bit(s)</b>	<b>Value</b>	<b>Description</b>
7:0	0	No effect on the corresponding DMA channel.
	1	Start (using auto-load) the corresponding DMA channel, using the buffer descriptor in memory addressed by the channel initial address register. This command should only be issued after the initial address has been loaded.

<b>DMA Master Halt Register (DMHR) (Address = 0x0102)</b>		
<b>Bit(s)</b>	<b>Value</b>	<b>Description</b>
7:0	0	No effect on the corresponding DMA channel.
	1	Halt the corresponding DMA channel. The DMA registers retain the current state, and the DMA can be restarted using DMCSR.

DMA y Buffer Complete Register		
		(D0BCR) (Address = 0x0103)
		(D1BCR) (Address = 0x0113)
		(D2BCR) (Address = 0x0123)
		(D3BCR) (Address = 0x0133)
		(D4BCR) (Address = 0x0143)
		(D5BCR) (Address = 0x0153)
		(D6BCR) (Address = 0x0163)
		(D7BCR) (Address = 0x0173)
Bit(s)	Value	Description
7:0	Read	The DMA increments a counter at the start of the next buffer. This count is latched in this register and can be used, along with the <i>buffer unused</i> count, to determine the actual amount of data transferred by the DMA. This counter is initialized by a start command or when the DMA is automatically rewound to the initial address.
	Write	Writing to this register loads the counter. This feature is intended only for testing, because the DMA automatically resets the counter to all ones when fetching from the initial address. The counter is incremented whenever the DMA fetches a new buffer length value from a descriptor.

DMA Master Control Register (DMCR) (Address = 0x0104)		
Bit(s)	Value	Description
7:4		These bits are reserved and should be written with zeros.
3:2	00	DMA transfers at Priority 0. No DMA transfers while CPU operates at Priority 3, 2, or 1.
	01	DMA transfers at Priority 1. No DMA transfers while CPU operates at Priority 3 or 2.
	10	DMA transfers at Priority 2. No DMA transfers while CPU operates at Priority 3.
	11	DMA transfers at Priority 3. DMA transfers at any time.
1:0	00	DMA interrupts are disabled.
	01	DMA interrupts use Interrupt Priority 1.
	10	DMA interrupts use Interrupt Priority 2.
	11	DMA interrupts use Interrupt Priority 3.

<b>DMA Master Timing Control Register (DMTCR) (Address = 0x0105)</b>		
<b>Bit(s)</b>	<b>Value</b>	<b>Description</b>
7:6	0x	Fixed DMA channel priority. Higher channel number has higher priority.
	10	Rotating DMA channel priority. Priority rotates highest channel number to lowest channel number after every byte is transferred.
	11	Rotating DMA channel priority. Priority rotates highest channel number to lowest channel number after the current channel request is serviced.
5:3	000	Maximum one byte per burst.
	001	Maximum two bytes per burst.
	010	Maximum three bytes per burst.
	011	Maximum four bytes per burst.
	100	Maximum eight bytes per burst.
	101	Maximum 16 bytes per burst.
	110	Maximum 32 bytes per burst.
	111	Maximum 64 bytes per burst.
2:0	000	Minimum 12 clocks between bursts.
	001	Minimum 16 clocks between bursts.
	010	Minimum 24 clocks between bursts.
	011	Minimum 32 clocks between bursts.
	100	Minimum 64 clocks between bursts.
	101	Minimum 128 clocks between bursts.
	110	Minimum 256 clocks between bursts.
	111	Minimum 512 clocks between bursts.

<b>DMA Master Request 0 Control Register (DMR0CR) (Address = 0x0106)</b>		
<b>Bit(s)</b>	<b>Value</b>	<b>Description</b>
7:6	00	External DMA Request 0 disabled.
	01	External DMA Request 0 enabled from Parallel Port D2.
	10	External DMA Request 0 enabled from Parallel Port E2.
	11	External DMA Request 0 enabled from Parallel Port E6.
5		This bit is reserved and should be written with zero.
4:3	00	External DMA Request 0 falling-edge triggered. One transfer per request.
	01	External DMA Request 0 rising-edge triggered. One transfer per request.
	10	External DMA Request 0 active low. Transfers continue while low.
	11	External DMA Request 0 active high. Transfers continue while high.
2:0	000	External DMA Request 0 supplied to DMA Channel 0.
	001	External DMA Request 0 supplied to DMA Channel 1.
	010	External DMA Request 0 supplied to DMA Channel 2.
	011	External DMA Request 0 supplied to DMA Channel 3.
	100	External DMA Request 0 supplied to DMA Channel 4.
	101	External DMA Request 0 supplied to DMA Channel 5.
	110	External DMA Request 0 supplied to DMA Channel 6.
	111	External DMA Request 0 supplied to DMA Channel 7.

<b>DMA Master Request 1 Control Register (DMR1CR) (Address = 0x0107)</b>		
<b>Bit(s)</b>	<b>Value</b>	<b>Description</b>
7:6	00	External DMA Request 1 disabled.
	01	External DMA Request 1 enabled from Parallel Port D3.
	10	External DMA Request 1 enabled from Parallel Port E3.
	11	External DMA Request 1 enabled from Parallel Port E7.
5		This bit is reserved and should be written with zero.
4:3	00	External DMA Request 1 falling-edge triggered. One transfer per request.
	01	External DMA Request 1 rising-edge triggered. One transfer per request.
	10	External DMA Request 1 active low. Transfers continue while low.
	11	External DMA Request 1 active high. Transfers continue while high.
2:0	000	External DMA Request 1 supplied to DMA Channel 0.
	001	External DMA Request 1 supplied to DMA Channel 1.
	010	External DMA Request 1 supplied to DMA Channel 2.
	011	External DMA Request 1 supplied to DMA Channel 3.
	100	External DMA Request 1 supplied to DMA Channel 4.
	101	External DMA Request 1 supplied to DMA Channel 5.
	110	External DMA Request 1 supplied to DMA Channel 6.
	111	External DMA Request 1 supplied to DMA Channel 7.

<b>DMA Timed Request Control Register (DTRCR) (Address = 0x0115)</b>		
<b>Bit(s)</b>	<b>Value</b>	<b>Description</b>
7	0	Timed DMA request disabled.
	1	Timed DMA request enabled.
6:5		These bits are reserved and should be written with zeros.
4:3	00	Timed DMA request transfers one byte per request.
	01	This bit combination is reserved and should not be used.
	10	Timed DMA request triggers transfers until current descriptor is complete. DMA channel fetches the next descriptor if appropriate.
	11	This bit combination is reserved and should not be used.
2:0	000	Timed DMA request supplied to DMA Channel 0.
	001	Timed DMA request supplied to DMA Channel 1.
	010	Timed DMA request supplied to DMA Channel 2.
	011	Timed DMA request supplied to DMA Channel 3.
	100	Timed DMA request supplied to DMA Channel 4.
	101	Timed DMA request supplied to DMA Channel 5.
	110	Timed DMA request supplied to DMA Channel 6.
	111	Timed DMA request supplied to DMA Channel 7.

<b>DMA Timed Request Divider Low Register (DTRDLR) (Address = 0x0116)</b>		
<b>Bit(s)</b>	<b>Value</b>	<b>Description</b>
7:0	Write	The eight LSBs of the limit value for the DMA timed request timer are stored.

<b>DMA Timed Request Divider High Register (DTRDHR) (Address = 0x0117)</b>		
<b>Bit(s)</b>	<b>Value</b>	<b>Description</b>
7:0	Write	The eight MSBs of the limit value for the DMA timed request timer are stored.

DMA y Termination Byte Register		
		(D0TBR) (Address = 0x0108)
		(D1TBR) (Address = 0x0118)
		(D2TBR) (Address = 0x0128)
		(D3TBR) (Address = 0x0138)
		(D4TBR) (Address = 0x0148)
		(D5TBR) (Address = 0x0158)
		(D6TBR) (Address = 0x0168)
		(D7TBR) (Address = 0x0178)
Bit(s)	Value	Description
7:0		Byte value that, if matched, will terminate a buffer.

DMA y Termination Mask Register		
		(D0TMR) (Address = 0x0109)
		(D1TMR) (Address = 0x0119)
		(D2TMR) (Address = 0x0129)
		(D3TMR) (Address = 0x0139)
		(D4TMR) (Address = 0x0149)
		(D5TMR) (Address = 0x0159)
		(D6TMR) (Address = 0x0169)
		(D7TMR) (Address = 0x0179)
Bit(s)	Value	Description
7:0		Mask for termination byte. A one in a bit position enables the corresponding bit of the termination byte to be used in the compare to generate the termination condition. A zero in a bit position disables the corresponding bit from contributing to the termination condition. A value of all zeros in this register disables the termination-byte match feature.

DMA y Buffer Unused[7:0] Register		
		(D0BU0R) (Address = 0x010A)
		(D1BU0R) (Address = 0x011A)
		(D2BU0R) (Address = 0x012A)
		(D3BU0R) (Address = 0x013A)
		(D4BU0R) (Address = 0x014A)
		(D5BU0R) (Address = 0x015A)
		(D6BU0R) (Address = 0x016A)
		(D7BU0R) (Address = 0x017A)
Bit(s)	Value	Description
7:0		Bits 7:0 of the buffer unused length value are stored in this register. The DMA copies the buffer remaining length to this register at the completion of the transfer. Normally the buffer remaining length is zero, but if the transfer terminates early, under source control or because of a termination-byte match, the number of unused bytes in the buffer is written.

<b>DMA y Buffer Unused[15:8] Register</b>		
	(D0BU1R)	(Address = 0x010B)
	(D1BU1R)	(Address = 0x011B)
	(D2BU1R)	(Address = 0x012B)
	(D3BU1R)	(Address = 0x013B)
	(D4BU1R)	(Address = 0x014B)
	(D5BU1R)	(Address = 0x015B)
	(D6BU1R)	(Address = 0x016B)
	(D7BU1R)	(Address = 0x017B)
Bit(s)	Value	Description
7:0		Bits 15:8 of the buffer unused-length value are stored in this register.

<b>DMA y Initial Addr[7:0] Register</b>		
	(D0IA0R)	(Address = 0x010C)
	(D1IA0R)	(Address = 0x011C)
	(D2IA0R)	(Address = 0x012C)
	(D3IA0R)	(Address = 0x013C)
	(D4IA0R)	(Address = 0x014C)
	(D5IA0R)	(Address = 0x015C)
	(D6IA0R)	(Address = 0x016C)
	(D7IA0R)	(Address = 0x017C)
Bit(s)	Value	Description
7:0		Bits 7:0 of the initial address are stored in this register.

<b>DMA y Initial Addr[15:8] Register</b>		
	(D0IA1R)	(Address = 0x010D)
	(D1IA1R)	(Address = 0x011D)
	(D2IA1R)	(Address = 0x012D)
	(D3IA1R)	(Address = 0x013D)
	(D4IA1R)	(Address = 0x014D)
	(D5IA1R)	(Address = 0x015D)
	(D6IA1R)	(Address = 0x016D)
	(D7IA1R)	(Address = 0x017D)
Bit(s)	Value	Description
7:0		Bits 15:8 of the initial address are stored in this register.

<b>DMA y Initial Addr[23:16] Register</b>		
	(D0IA2R)	(Address = 0x010E)
	(D1IA2R)	(Address = 0x011E)
	(D2IA2R)	(Address = 0x012E)
	(D3IA2R)	(Address = 0x013E)
	(D4IA2R)	(Address = 0x014E)
	(D5IA2R)	(Address = 0x015E)
	(D6IA2R)	(Address = 0x016E)
	(D7IA2R)	(Address = 0x017E)
Bit(s)	Value	Description
7:0		Bits 23:16 of the initial address are stored in this register.



DMA y Special Control Register		
		(D0SCR) (Address = 0x0180)
		(D1SCR) (Address = 0x0190)
		(D2SCR) (Address = 0x01A0)
		(D3SCR) (Address = 0x01B0)
		(D4SCR) (Address = 0x01C0)
		(D5SCR) (Address = 0x01D0)
		(D6SCR) (Address = 0x01E0)
		(D7SCR) (Address = 0x01F0)
Bit(s)	Value	Description
7:4		These bits are reserved and will always be read as zeros.
3	0	Auto-connect source DMA request.
	1	Disconnect source DMA request (full buffer transfer).
2	0	Normal source address.
	1	Source address fixed, independent of type.
1	0	Auto-connect destination DMA request.
	1	Disconnect destination DMA request (full buffer transfer).
0	0	Normal destination address.
	1	Destination address fixed, independent of type.

DMA y Control Register		
		(D0CR) (Address = 0x0181)
		(D1CR) (Address = 0x0191)
		(D2CR) (Address = 0x01A1)
		(D3CR) (Address = 0x01B1)
		(D4CR) (Address = 0x01C1)
		(D5CR) (Address = 0x01D1)
		(D6CR) (Address = 0x01E1)
		(D7CR) (Address = 0x01F1)
Bit(s)	Value	Description
7	0	Continue to next buffer descriptor.
	1	Final buffer descriptor. Stop DMA operation upon completion of this transfer.
6	0	Use sequential address for next buffer descriptor. The link address field is not present in this buffer descriptor, which is now 12 bytes long.
	1	Use the link address field as a pointer to the next buffer descriptor. This buffer descriptor is 16 bytes long.
5	0	No special treatment for last byte.
	1	Internal Source: status byte written to initial buffer descriptor before last data. Internal Destination: Last byte written to offset address for frame termination. All others: No effect.
4	0	No interrupt on completing this transfer.
	1	Interrupt on completing this transfer.
3:2	00	Source address is fixed internal I/O (two-byte) address.
	01	Source address is fixed external I/O (two-byte) address.
	10	Source address is memory (three-byte) address, auto-decrement.
	11	Source address is memory (three-byte) address, auto-increment.
1:0	00	Destination address is fixed internal I/O (two-byte) address.
	01	Destination address is fixed external I/O (two-byte) address.
	10	Destination address is memory (three-byte) address, auto-decrement.
	11	Destination address is memory (three-byte) address, auto-increment.

DMA y Length[7:0] Register		
		(D0L0R) (Address = 0x0182)
		(D1L0R) (Address = 0x0192)
		(D2L0R) (Address = 0x01A2)
		(D3L0R) (Address = 0x01B2)
		(D4L0R) (Address = 0x01C2)
		(D5L0R) (Address = 0x01D2)
		(D6L0R) (Address = 0x01E2)
		(D7L0R) (Address = 0x01F2)
Bit(s)	Value	Description
7:0		Bits 7:0 of the buffer length value are stored in this register. The DMA does a transfer followed by a decrement of this register, so an initial value of 0x0000 will result in a 65536-byte transfer.

DMA y Length[15:8] Register		
		(D0L1R) (Address = 0x0183)
		(D1L1R) (Address = 0x0193)
		(D2L1R) (Address = 0x01A3)
		(D3L1R) (Address = 0x01B3)
		(D4L1R) (Address = 0x01C3)
		(D5L1R) (Address = 0x01D3)
		(D6L1R) (Address = 0x01E3)
		(D7L1R) (Address = 0x01F3)
Bit(s)	Value	Description
7:0		Bits 15:8 of the buffer length value are stored in this register.

<b>DMA y Source Addr[7:0] Register</b>		
	(D0SA0R)	(Address = 0x0184)
	(D1SA0R)	(Address = 0x0194)
	(D2SA0R)	(Address = 0x01A4)
	(D3SA0R)	(Address = 0x01B4)
	(D4SA0R)	(Address = 0x01C4)
	(D5SA0R)	(Address = 0x01D4)
	(D6SA0R)	(Address = 0x01E4)
	(D7SA0R)	(Address = 0x01F4)
Bit(s)	Value	Description
7:0		Bits 7:0 of the source address are stored in this register.

<b>DMA y Source Addr[15:8] Register</b>		
	(D0SA1R)	(Address = 0x0185)
	(D1SA1R)	(Address = 0x0195)
	(D2SA1R)	(Address = 0x01A5)
	(D3SA1R)	(Address = 0x01B5)
	(D4SA1R)	(Address = 0x01C5)
	(D5SA1R)	(Address = 0x01D5)
	(D6SA1R)	(Address = 0x01E5)
	(D7SA1R)	(Address = 0x01F5)
Bit(s)	Value	Description
7:0		Bits 15:8 of the source address are stored in this register.

<b>DMA y Source Addr[23:16] Register</b>		
	(D0SA2R)	(Address = 0x0186)
	(D1SA2R)	(Address = 0x0196)
	(D2SA2R)	(Address = 0x01A6)
	(D3SA2R)	(Address = 0x01B6)
	(D4SA2R)	(Address = 0x01C6)
	(D5SA2R)	(Address = 0x01D6)
	(D6SA2R)	(Address = 0x01E6)
	(D7SA2R)	(Address = 0x01F6)
Bit(s)	Value	Description
7:0		Bits 23:16 of the source address are stored in this register.

<b>DMA y Destination Addr[7:0] Register</b>		
	(D0DA0R)	(Address = 0x0188)
	(D1DA0R)	(Address = 0x0198)
	(D2DA0R)	(Address = 0x01A8)
	(D3DA0R)	(Address = 0x01B8)
	(D4DA0R)	(Address = 0x01C8)
	(D5DA0R)	(Address = 0x01D8)
	(D6DA0R)	(Address = 0x01E8)
	(D7DA0R)	(Address = 0x01F8)
Bit(s)	Value	Description
7:0		Bits 7:0 of the destination address are stored in this register.

<b>DMA y Destination Addr[15:8] Register</b>		
	(D0DA1R)	(Address = 0x0189)
	(D1DA1R)	(Address = 0x0199)
	(D2DA1R)	(Address = 0x01A9)
	(D3DA1R)	(Address = 0x01B9)
	(D4DA1R)	(Address = 0x01C9)
	(D5DA1R)	(Address = 0x01D9)
	(D6DA1R)	(Address = 0x01E9)
	(D7DA1R)	(Address = 0x01F9)
Bit(s)	Value	Description
7:0		Bits 15:8 of the destination address are stored in this register.

<b>DMA y Destination Addr[23:16] Register</b>		
	(D0DA2R)	(Address = 0x018A)
	(D1DA2R)	(Address = 0x019A)
	(D2DA2R)	(Address = 0x01AA)
	(D3DA2R)	(Address = 0x01BA)
	(D4DA2R)	(Address = 0x01CA)
	(D5DA2R)	(Address = 0x01DA)
	(D6DA2R)	(Address = 0x01EA)
	(D7DA2R)	(Address = 0x01FA)
Bit(s)	Value	Description
7:0		Bits 23:16 of the destination address are stored in this register.

<b>DMA y Link Addr[7:0] Register</b>		
	(D0LA0R)	(Address = 0x018C)
	(D1LA0R)	(Address = 0x019C)
	(D2LA0R)	(Address = 0x01AC)
	(D3LA0R)	(Address = 0x01BC)
	(D4LA0R)	(Address = 0x01CC)
	(D5LA0R)	(Address = 0x01DC)
	(D6LA0R)	(Address = 0x01EC)
	(D7LA0R)	(Address = 0x01FC)
Bit(s)	Value	Description
7:0		Bits 7:0 of the link address are stored in this register.

<b>DMA y Link Addr[15:8] Register</b>		
	(D0LA1R)	(Address = 0x018D)
	(D1LA1R)	(Address = 0x019D)
	(D2LA1R)	(Address = 0x01AD)
	(D3LA1R)	(Address = 0x01BD)
	(D4LA1R)	(Address = 0x01CD)
	(D5LA1R)	(Address = 0x01DD)
	(D6LA1R)	(Address = 0x01ED)
	(D7LA1R)	(Address = 0x01FD)
Bit(s)	Value	Description
7:0		Bits 15:8 of the link address are stored in this register.

<b>DMA y Link Addr[23:16] Register</b>		
	(D0LA2R)	(Address = 0x018E)
	(D1LA2R)	(Address = 0x019E)
	(D2LA2R)	(Address = 0x01AE)
	(D3LA2R)	(Address = 0x01BE)
	(D4LA2R)	(Address = 0x01CE)
	(D5LA2R)	(Address = 0x01DE)
	(D6LA2R)	(Address = 0x01EE)
	(D7LA2R)	(Address = 0x01FE)
Bit(s)	Value	Description
7:0		Bits 23:16 of the link address are stored in this register.

## 22. 10/100BASE-T ETHERNET

### 22.1 Overview

Network Port B implements a full 10/100Base-T Ethernet MAC with an industry-standard MII interface for an external PHY chip. The MAC is fully compliant with the IEEE 802.3 Ethernet standard, including support for auto-negotiation, link detection, multicast filtering, and broadcast addresses. A wide variety of transmit and receive options are available, including control over frame size, CRC attachment, maximum allowed frame size, and interpacket gap length.

The receiver and transmitter each have a 2048-byte FIFO that is shared with the Wi-Fi peripheral; the I/O pins are also shared. Because of this, only one of the two network peripherals can be enabled at any time.

The Network Port B receiver transfers both data and status information to memory via the DMA, eliminating the need for receive data or status interrupts and dedicated receive status registers. The network port appends six bytes of status information to the last byte of the received data. Buffer and byte counts in the DMA can be used to find this status information in memory. In cases where a received frame has been discarded because of an error, only these six bytes of status will be transferred to memory. The DMA must be programmed to close a buffer on end-of-frame, as the network port marks the last byte of status this way.

The Network Port B transmitter uses interrupts because the DMA has no way of knowing when (or if) the frame has successfully been sent. Both the receive and transmit FIFOs are capable of DMA fly-by operation.

The network port requires an accurate 25 MHz clock to generate the 100 Mbits/s serial rate of 100Base-T. This clock comes from the external PHY chip, and is input on separate pins for the transmit and receive channels. The clock for the network port may also be disabled to conserve power. The network port contains synchronization circuitry to allow operation from the 25 MHz reference clock while the main system clock runs independently.

The network port transmitter precedes the transmit data automatically with a preamble and start-frame-delimiter, and appends CRC and the end-frame delimiter after the last byte. Frame transmission starts automatically once the transmit FIFO is complete and any inter-frame gap time or back-off time has expired. Transmission is aborted if a collision is detected, and is retried up to 16 times using the standard random back-off time algorithm. Detection of a collision causes the transmitter to send a 32-bit “jam” pattern of all ones to guarantee that all receivers in the network recognize the collision.

The network port receiver uses the received preamble to synchronize to the phase of the incoming frame, and then waits for the start-frame delimiter. Character assembly begins at this point, and each byte is transferred to the receive FIFO. However, no interrupt or DMA request will occur until after the first six bytes of the frame have been received and checked for an address match. The receiver can receive frames independent of the address (promiscuous mode), or it can receive frames with a physical address match, a broadcast address match, or a multicast address match.

Normal DMA transfers of data begin once an address match occurs, and continue until the end-frame delimiter is recognized or the line goes idle because of a collision. The network receiver calculates the CRC across the entire frame in parallel with character assembly, and reports the result when the end-frame delimiter is recognized. Normally frames with bad CRC are discarded. The receiver also reports misaligned end-frame delimiters (those that do not occur on byte boundaries).

The network port implements the NLP receive link integrity test state machine, which requires link integrity pulses to be detected at certain intervals in the absence of other network activity. If the network receiver enters the NLP Link Test Fail state because of missing link-test pulses, this state machine requires seven successive properly timed link test pulses (or an equal number of FLP bursts) before reporting that the link is again active. The reset state of this state machine is link-inactive. Note that this is a subtle difference relative to the normal 10Base-T receive link-integrity state machine, which requires either link test pulses or carrier sense to make the link active.

The network port implements the auto-negotiation algorithm to determine half-duplex or full-duplex operation. In addition to its normal automatic operation, this feature can be disabled or commanded to execute under software control.

The MII interface consists of 20 pins as specified in IEEE 802.3 standard. Two clocks are provided on the interface, one for transmit and one for receive.

The two A/D converters and single D/A converter are available for customer use when the Ethernet peripheral is enabled.



## 22.1.1 Block Diagram

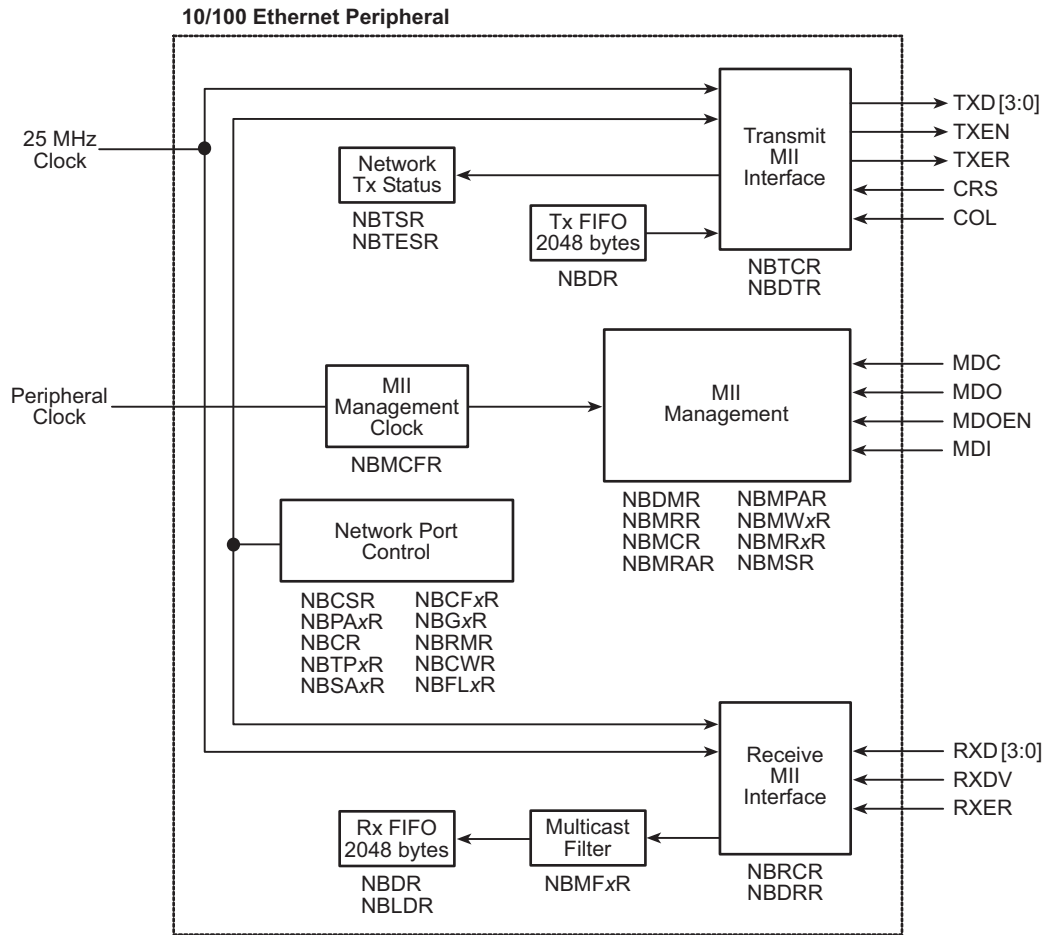

## 22.1.2 Registers

Register Name	Mnemonic	I/O Address	R/W	Reset
Network Port B Data Register	NBDR	0x0200	R/W	xxxxxxxx
Network Port B Last Data Register	NBLDR	0x0201	W	xxxxxxxx
Network Port B Transmit Status Register	NBTSR	0x0202	R	00000000
Network Port B Control/Status Register	NBCSR	0x0204	R/W	00000000
Network Port B Command Register	NBCR	0x0206	W	00000000
Network Port B Transmit Pause LSB Register	NBTPLR	0x0208	R/W	00000000
Network Port B Transmit Pause MSB Register	NBTPMR	0x0209	R/W	00000000
Network Port B Transmit Control Register	NBTCR	0x020A	R/W	00000000
Network Port B Receive Control Register	NBRCR	0x020B	R/W	00000000
Network Port B Transmit Extra Status Register	NBTESR	0x020C	R/W	00000000
Network Port B Phys. Addr. [7:0] Register	NBPA0R	0x0210	W	xxxxxxxx
Network Port B Phys. Addr. [15:8] Register	NBPA1R	0x0211	W	xxxxxxxx
Network Port B Phys. Addr. [23:16] Register	NBPA2R	0x0212	W	xxxxxxxx
Network Port B Phys. Addr. [31:24] Register	NBPA3R	0x0213	W	xxxxxxxx
Network Port B Phys. Addr. [39:32] Register	NBPA4R	0x0214	W	xxxxxxxx
Network Port B Phys. Addr. [47:40] Register	NBPA5R	0x0215	W	xxxxxxxx
Network Port B Multicast Filter [7:0] Register	NBMF0R	0x0218	R/W	xxxxxxxx
Network Port B Multicast Filter [15:8] Register	NBMF1R	0x0219	R/W	xxxxxxxx
Network Port B Multicast Filter [23:16] Register	NBMF2R	0x021A	R/W	xxxxxxxx
Network Port B Multicast Filter [31:24] Register	NBMF3R	0x021B	R/W	xxxxxxxx
Network Port B Multicast Filter [39:32] Register	NBMF4R	0x021C	R/W	xxxxxxxx
Network Port B Multicast Filter [47:40] Register	NBMF5R	0x021D	R/W	xxxxxxxx
Network Port B Multicast Filter [55:48] Register	NBMF6R	0x021E	R/W	xxxxxxxx
Network Port B Multicast Filter [63:56] Register	NBMF7R	0x021F	R/W	xxxxxxxx
Network Port B Direct Rx Register	NBDRR	0x0228	R	xxxxxxxx
Network Port B Direct Tx Register	NBDTR	0x0229	W	xxxxxxxx
Network Port B Direct MII Register	NBDMR	0x022A	R/W	xxxxxxxx
Network Port B Configuration 0 Register	NBCF0R	0x0240	R/W	00000000
Network Port B Configuration 1 Register	NBCF1R	0x0241	R/W	00000000
Network Port B Configuration 2 Register	NBCF2R	0x0242	R/W	00000000
Network Port B Configuration 3 Register	NBCF3R	0x0243	R/W	00000000
Network Port B Gap 0 Register	NBG0R	0x0244	R/W	00000000

Register Name	Mnemonic	I/O Address	R/W	Reset
Network Port B Gap 2 Register	NBG2R	0x0246	R/W	00000000
Network Port B Gap 1 Register	NBG1R	0x0247	R/W	00000000
Network Port B Retransmit Max Register	NBRMR	0x0248	R/W	00000000
Network Port B Collision Window Register	NBCWR	0x0249	R/W	00000000
Network Port B Frame Limit LSB Register	NBFLLR	0x024A	R/W	00000000
Network Port B Frame Limit MSB Register	NBFLMR	0x024B	R/W	00000000
Network Port B MII Configuration Register	NBMCFR	0x0250	R/W	00000000
Network Port B MII Reset Register	NBMRR	0x0251	R/W	00000000
Network Port B MII Command Register	NBMCR	0x0252	R/W	00000000
Network Port B MII Register Address Register	NBMRAR	0x0254	R/W	00000000
Network Port B MII PHY Address Register	NBMPAR	0x0255	R/W	00000000
Network Port B MII Write LSB Register	NBMWLR	0x0256	W	00000000
Network Port B MII Write MSB Register	NBMWMR	0x0257	W	00000000
Network Port B MII Read LSB Register	NBMRLR	0x0258	R	00000000
Network Port B MII Read MSB Register	NBMRMR	0x0259	R	00000000
Network Port B MII Status Register	NBMSR	0x025A	R/W	00000000
Network Port B Station Address 0 Register	NBSA0R	0x0260	R/W	00000000
Network Port B Station Address 1 Register	NBSA1R	0x0261	R/W	00000000
Network Port B Station Address 2 Register	NBSA2R	0x0262	R/W	00000000
Network Port B Station Address 3 Register	NBSA3R	0x0263	R/W	00000000
Network Port B Station Address 4 Register	NBSA4R	0x0264	R/W	00000000
Network Port B Station Address 5 Register	NBSA5R	0x0265	R/W	00000000
Enable Network Port Register	ENPR	0x0430	R/W	00000000

## 22.2 Dependencies

### 22.2.1 I/O Pins

The network port MII interface has 20 dedicated pins, which are listed in Table 22-1. These pins can be used as general-purpose inputs and outputs if the network port is not being used via NBDRR, NBDTR, and NBDMR.

**Table 22-1. Network Port MII Interface**

Section	Signal	Direction	Function
Transmit	TXD[3:0]	Output	Transmit data to PHY
	TX_EN	Output	Transmit enable
	TX_ER	Output	Transmit error
	CRS	Input	Carrier sense
	COL	Input	Collision detect
	TX_CLK	Input	Transmit clock (25 MHz)
Receive	RXD[3:0]	Input	Receive data from PHY
	RX_DV	Input	Receive data valid
	RX_ER	Input	Receive data error
	RX_CLK	Input	Receive clock (25 MHz)
Management	MDC	Output	Management data clock (varies)
	MDI	Input	Management data input
	MDO	Output	Management data output
	MDOEN	Output	Management data output enable

### 22.2.2 Clocks

The network port requires a 25 MHz clock input for proper 10/100Base-T operation; this clock is normally supplied separately to the receive and transmit portions of the peripheral on the RX\_CLK and TX\_CLK pins. The management data clock on MDC is generated by the Rabbit 5000 by dividing down the peripheral clock as selected in NBMCFR.

### 22.2.3 Other Registers

Register	Function
EDMR	Enable 10/100 Ethernet functionality.

## 22.2.4 Interrupts

The network interrupt can be generated by an Ethernet frame being transmitted correctly, transmitted with an error, or if a transmit pause occurs (control frame is transmitted but not the data). The events that generate an interrupt can be selected in NBCSR.

The receive frame status is attached to the end of the data frame itself, so the DMA interrupt can be used to handle received frame. See Section 22.3 for more details.

The network port interrupt vector is shared with Network Port C, the Wi-Fi network port. It is located in the IIR at offset 0x1E0. It can be set as Priority 1, 2, or 3 by writing to ENPR.

## 22.3 Operation

High-level support for TCP/IP and other protocols is beyond the scope of this manual, but this section will describe the low-level setup and operation of the 10/100Base-T Ethernet peripheral.

The contents of the six status bytes are shown below. Note that any status block marked with RxOV (receive overflow) is invalid, as the FIFO could not hold the entire frame. Only the marked frame is invalid, so any previous frames read from the FIFO are fine. Once an overflow is detected, no subsequent frames can be buffered to the FIFO until a FIFO purge command is written to the NBCR.

Status Byte	Bit 7	Bit 6	Bit 5	Bit 4	Bit 3	Bit 2	Bit 1	Bit 0
First	LSB of Rx Checksum							
Second	MSB of Rx Checksum							
Third	Receive Status Vector [7:0] (LSB of receive frame length)							
Fourth	Receive Status Vector [15:8] (MSB of receive frame length)							
Fifth	Receive Status Vector [23:16]							
Last	RxOV	Receive Status Vector [30:24]						

### 22.3.1 Setup

The following steps explain how to set up Network Port B.

1. Write the interrupt vector for the interrupt service routine to the external interrupt table.
2. Select the desired interrupts and interrupt priority by writing to NBCSR.
3. Select the MII interface settings by writing to NBMCFR, NBMRAR, and NBMPAR.
4. Select the desired configuration of transmit and receive operation by writing to NBTCR, NBTESR, and MBRCR.
5. Write the device's physical MAC address to the physical address (NBPxR) and station address registers (NBSAxR).
6. If desired, write to the multicast filter registers (NBMFxR) to generate a multicast filter.
7. Select other options in the configuration registers NBCFxR, NBGxR, NBRMR, NBCWR, and NBFLxR.
8. Enable the network port transmitter by writing to NBTCR.
9. Enable the network port receiver by writing to NBRCR.

### 22.3.2 Transmit

The following steps explain how to transmit an Ethernet packet.

1. Set up a DMA buffer descriptor that will read the packet data from memory and write it to NBDR. Write the buffer descriptor's address to the DMA's initial address registers (see Chapter 21 for more information).
2. Enable the DMA transfer by auto-loading the buffer.
3. The packet transmission will proceed automatically. If any interrupts were enabled for any transmitted packet events, they will occur upon completion (or error).

Note that network interrupts will occur when the data appears in the network peripheral, but DMA interrupts will occur when the DMA transfer is complete.

### 22.3.3 Receive

The following steps explain how to receive an Ethernet packet.

1. Set up a DMA buffer descriptor that will read the packet data from NBDR and write it to memory. Write the buffer descriptor's address to the DMA's initial address registers (see Chapter 21 for more information).
2. Set up a DMA interrupt to handle the packet once it has been received and copied to memory.
3. Enable the DMA transfer by auto-loading the buffer.
4. The packet transmission will proceed automatically when data come in. When the DMA transfer is complete, the DMA interrupt can be used to start the packet processing. The status of the received packet is appended to the received data.

### 22.3.4 Handling Interrupts

The network port transmit interrupt is automatically cleared by reading NBCSR; received packets are handled via the DMA interrupt, which is automatically cleared when the ISR is called.

A sample packet transmit interrupt handler is shown below.

```
network_isr::
    push af
    ioi ld a, (NBCSR)      ; read the interrupt status
    push af                ; save status byte for later
    bit 4,a                ; did transmit error occur?
    jp nz, handle_tx_err
    bit 4,a                ; did transmit pause occur?
    jp nz, handle_pause_err

done:
    pop af
    ipres
    ret

handle_tx_err:
    ioi ld a, (NBTSR)     ; get transmitter status
    ; check why error occurred and respond accordingly
    pop af
    pop af
    ipres
    ret

handle_pause_err:
    ; handle transmit pause
    pop af
    ipres
    ret
```

A sample packet receive interrupt handler is shown below.

```
dma_eth_rx_isr::
    ; interrupt is automatically cleared
    ; check status bytes appended to packet just received
    ipres
    ret
```

### 22.3.5 Multicast Addressing

A physical address match requires that the received frame address is a physical address that matches every bit of the programmed receive address. A broadcast address match requires that all 48 bits of the received frame address be “ones.” A multicast address match requires the received frame address to be a multicast address (LSB of the address is one) and a match in the multicast address filter. The multicast address filter uses the six most significant bits of the CRC calculated on the receive address as an index into a 64-by-1 bit table written under program control. A one in the corresponding table entry constitutes a multicast address match as far as the network port is concerned. A table of one set of unique multicast addresses corresponding to each filter bit is shown below. The table shows the least significant byte of the multicast address; the remaining five bytes of the address are all zeros for this set of multicast addresses.

Register	Bit 7	Bit 6	Bit 5	Bit 4	Bit 3	Bit 2	Bit 1	Bit 0
NBMF7R	0x17	0x0B	0x05	0x19	0x85	0x99	0x97	0x8B
NBMF6R	0xD9	0xC5	0xCB	0xD7	0x4B	0x57	0x59	0x45
NBMF5R	0xCF	0xD3	0xDD	0xC1	0x5D	0x41	0x4F	0x53
NBMF4R	0x01	0x1D	0x13	0x0F	0x93	0x8F	0x81	0x9D
NBMF3R	0x5F	0x43	0x4D	0x51	0xCD	0xD1	0xDF	0xC3
NBMF2R	0x91	0x8D	0x83	0x9F	0x03	0x1F	0x11	0x0D
NBMF1R	0x87	0x9B	0x95	0x89	0x15	0x09	0x07	0x1B
NBMF0R	0x49	0x55	0x5B	0x47	0xDB	0xC7	0xC9	0xD5



## 22.4 Register Descriptions

<b>Network Port B Data Register (NBDR) (Address = 0x0200)</b>		
<b>Bit(s)</b>	<b>Value</b>	<b>Description</b>
7:0	Read	Returns the contents of the receive buffer. This register is not normally accessed by the processor, but is accessed by the DMA channels.
	Write	Loads the transmit buffer with a data byte for transmission.

<b>Network Port B Last Data Register (NBLDR) (Address = 0x0201)</b>		
<b>Bit(s)</b>	<b>Value</b>	<b>Description</b>
7:0	Read	Returns the contents of the receive buffer. This register is not normally accessed by the processor, but is accessed by the DMA channels.
	Write	Loads the transmit buffer with the last data byte of a frame to enable the subsequent transmission of the CRC. The DMA automatically writes the last byte of the frame to this address.

<b>Network Port B Transmit Status Register (NBTSR) (Address = 0x0202)</b>		
<b>Bit(s)</b>	<b>Value</b>	<b>Description</b>
7	0	Frame transmission not complete.
	1	Frame transmission complete.
6	0	Frame transmission is not deferring.
	1	Frame transmission is deferring.
5	0	No excessive collisions.
	1	Frame transmission aborted due to excessive collisions.
4	0	No transmit underrun.
	1	Frame transmission aborted because of a FIFO underrun.
3	0	Frame transmission not too long.
	1	Frame transmission too long.
2	0	No excessive defers.
	1	Frame transmission deferred excessively.
1	0	No collisions.
	1	Frame transmission encountered at least one collision.
0	0	No late collisions.
	1	Frame transmission encountered a late collision (later than one slot time).

<b>Network Port B Control/Status Register (NBCSR) (Address = 0x0204)</b>		
<b>Bit(s)</b>	<b>Value</b>	<b>Description</b>
7:6		These bits are reserved and will always read as zero.
5:3 (Write-only)	0	The corresponding interrupt is disabled.
	1	The corresponding interrupt is enabled.
5:3	Read	These bits, and the Network Port interrupt, are automatically cleared by a read of this register. The individual interrupt enables are not affected.
5 (Read-only)	0	No transmit okay interrupt.
	1	Transmit okay interrupt.
4 (Read-only)	0	No transmit error interrupt.
	1	Transmit error interrupt.
3 (Read-only)	0	No transmit pause interrupt.
	1	Transmit pause interrupt (control frame complete).
2	0	This bit is reserved and will always read as zero.
1:0	00	The Network Port interrupt is disabled.
	01	The Network Port uses Interrupt Priority 1.
	10	The Network Port uses Interrupt Priority 2.
	11	The Network Port uses Interrupt Priority 3.

<b>Network Port B Command Register (NBCR) (Address = 0x0206)</b>		
<b>Bit(s)</b>	<b>Value</b>	<b>Description</b>
7	0	No operation.
	1	Transmit start command.
6	0	No operation.
	1	Transmit PAUSE control frame command.
5	0	No operation.
	1	Transmit half-duplex backpressure.
4	0	No operation.
	1	Transmit FIFO purge command.
3:1		These bits are ignored and should always be written as zeros.
0	0	No operation.
	1	Receive FIFO purge command.

<b>Network Port B Transmit Pause LSB Register (NBTPLR) (Address = 0x0208)</b>		
<b>Bit(s)</b>	<b>Value</b>	<b>Description</b>
7:0		LSB of parameter sent in PAUSE control frame.

<b>Network Port B Transmit Pause MSB Register (NBTPMR) (Address = 0x0209)</b>		
<b>Bit(s)</b>	<b>Value</b>	<b>Description</b>
7:0		MSB of parameter sent in PAUSE control frame.

<b>Network Port B Transmit Control Register (NBTCR) (Address = 0x020A)</b>		
<b>Bit(s)</b>	<b>Value</b>	<b>Description</b>
7:6	00	Disable transmit FIFO.
	01	DMA request when frame transmission is complete.
	10	Reserved.
	11	Reserved.
5:4	00	Start transmit on command only.
	01	Start transmit on command or Last Byte written.
	10	Start transmit on command, when FIFO is half full, or Last Byte written.
	11	Start transmit on command, when FIFO is one-fourth full, or Last Byte written.
3:0		These bits are reserved and should be written with zeros.

<b>Network Port B Receive Control Register (NBRCR) (Address = 0x020B)</b>		
<b>Bit(s)</b>	<b>Value</b>	<b>Description</b>
7:6	00	Disable receive FIFO.
	01	DMA request when frame reception is complete.
	10	DMA request when FIFO is half full or frame reception is complete.
	11	DMA request when FIFO is one-fourth full or frame reception is complete.
5	0	Normal receiver operation.
	1	Place receiver in Monitor Mode. Receiver operates normally, but does not buffer frames to memory.
4	0	Receive frames less than 64 bytes in length discarded.
	1	Receive frames as short as 8 bytes accepted.
3	0	Receive frames with errors discarded. Reclaim buffer space.
	1	Receive frames with errors accepted. Do not reclaim buffer space.
2	0	Receive frames with broadcast address ignored.
	1	Receive frames with broadcast address accepted
1	0	Receive frames with multicast addresses ignored.
	1	Receive frames with multicast addresses accepted if passing hashing filter.
0	0	Receive frames with mismatched physical addresses are ignored.
	1	Receive frames with any physical address accepted. Promiscuous mode.

<b>Network Port B Transmit Extra Status Register (NBTESR) (Address = 0x020C)</b>		
<b>Bit(s)</b>	<b>Value</b>	<b>Description</b>
7		This bit is reserved and will always be read as zero.
6	0	No transmit length out-of-range, or not checked.
	1	Transmit frame had length out-of-range error.
5	0	No transmit length check error, or transmit length not checked.
	1	Transmit frame had length check error.
4	0	No transmit CRC error, or transmit CRC not checked.
	1	Transmit frame had CRC error.
3:0		Transmit frame collision count.

<b>Network Port B Physical Address x Register (NBPA0R) (Address = 0x0210)</b>		
<b>(NBPA1R) (Address = 0x0211)</b>		
<b>(NBPA2R) (Address = 0x0212)</b>		
<b>(NBPA3R) (Address = 0x0213)</b>		
<b>(NBPA4R) (Address = 0x0214)</b>		
<b>(NBPA5R) (Address = 0x0215)</b>		
<b>Bit(s)</b>	<b>Value</b>	<b>Description</b>
7:0	Write	Byte of physical address for receive address filtering.

<b>Network Port B Multicast Filter x Register (NBMF0R) (Address = 0x0218)</b>		
<b>(NBMF1R) (Address = 0x0219)</b>		
<b>(NBMF2R) (Address = 0x021A)</b>		
<b>(NBMF3R) (Address = 0x021B)</b>		
<b>(NBMF4R) (Address = 0x021C)</b>		
<b>(NBMF5R) (Address = 0x021D)</b>		
<b>(NBMF6R) (Address = 0x021E)</b>		
<b>(NBMF7R) (Address = 0x021F)</b>		
<b>Bit(s)</b>	<b>Value</b>	<b>Description</b>
7:0	Write	Eight bits of the multicast filter. At the end of a received multicast address, the upper six bits of CRC are used as an index into this 64-bit table. If the corresponding bit is zero, the frame is discarded. If the corresponding bit is one, the frame is accepted.

<b>Network Port B Direct Rx Register (NBDRR) (Address = 0x0228)</b>		
<b>Bit(s)</b>	<b>Value</b>	<b>Description</b>
7:4	Read	Returns the state of the RXD pins.
3	Read	Returns the state of the RX_ER pin.
2	Read	Returns the state of the RX_DV pin.
1	Read	Returns the state of the RX_CLK pin.
0	Read	Returns the state of the CRS pin.

<b>Network Port B Direct Tx Register (NBDTR) (Address = 0x0229)</b>		
<b>Bit(s)</b>	<b>Value</b>	<b>Description</b>
7:4	Write	Controls the state of the TXD pins if both network ports are disabled.
3	Write	Controls the state of the TX_ER pin if both network ports are disabled.
2	Write	Controls the state of the TX_EN pin if both network ports are disabled.
1	Read	Returns the state of the TX_CLK pin.
0	Read	Returns the state of the COL pin.

<b>Network Port B Direct MII Register (NBDMR) (Address = 0x022A)</b>		
<b>Bit(s)</b>	<b>Value</b>	<b>Description</b>
7:4		These bits are reserved and should be written with zeros. Reads return zeros.
3	Write	Controls the state of the MDO pin if both network ports are disabled.
2	Write	Controls the state of the MDOEN pin if both network ports are disabled.
1	Write	Controls the state of the MDC pin if both network ports are disabled.
0	Read	Returns the state of the MDI pin.

<b>Network Port B Configuration 0 Register (NBCF0R) (Address = 0x0240)</b>		
<b>Bit(s)</b>	<b>Value</b>	<b>Description</b>
7:5		These bits are ignored and will always return zeros when read.
4	0	Disable loopback.
	1	Enable loopback.
3	0	Disable transmit flow control.
	1	Enable transmit flow control (PAUSE control frames).
2	0	Disable receive flow control.
	1	Enable receive flow control (PAUSE control frames).
1	0	Pass normal receive frames only.
	1	Pass all receive frames (normal or control).
0	0	Disable receiver.
	1	Enable receiver.

<b>Network Port B Configuration 1 Register (NBCF1R) (Address = 0x0241)</b>		
<b>Bit(s)</b>	<b>Value</b>	<b>Description</b>
7	0	No operation.
	1	Reset entire MAC.
6	0	No operation.
	1	Reset transmit random number generator.
5:4		These bits are ignored and will always return zeros when read.
3	0	No operation.
	1	Reset MAC control sublayer/receive domain logic.
2	0	No operation.
	1	Reset receiver.
1	0	No operation.
	1	Reset MAC control sublayer/transmit domain logic.
0	0	No operation.
	1	Reset transmitter.

<b>Network Port B Configuration 2 Register (NBCF2R) (Address = 0x0242)</b>		
<b>Bit(s)</b>	<b>Value</b>	<b>Description</b>
7:5	xx0	Disable transmit pad operation. Check CRC if not appended.
	001	Pad transmit frames to 60 bytes, append CRC.
	x11	Pad transmit frames to 64 bytes, append CRC.
	101	Pad transmit frames to 60 bytes (not VLAN tagged) or 64 bytes (VLAN tagged), append CRC.
4	0	Disable transmit CRC insertion.
	1	Enable transmit CRC insertion. Must be set if bit 5 is set.
3	0	Normal 802.3 frame structure.
	1	Enable 4-byte header (ignored by CRC).
2	0	Normal 802.3 frame length restrictions.
	1	Enable huge frames (transmit and receive).
1	0	Disable frame length checking.
	1	Enable frame length checking (transmit and receive).
0	0	Enable half-duplex.
	1	Enable full-duplex.

<b>Network Port B Configuration 3 Register (NBCF3R) (Address = 0x0243)</b>		
<b>Bit(s)</b>	<b>Value</b>	<b>Description</b>
7		This bit is ignored and will always return zero when read.
6	0	Abort transmit on excessive deferral.
	1	Defer to carrier indefinitely.
5	0	Normal transmit operation after back-pressure collision.
	1	Enable immediate transmission after back-pressure collision.
4	0	Normal 802.3 back-off operation.
	1	Enable immediate retransmit (no back-off).
3:2		These bits are ignored and will always return zeros when read.
1	0	Disable preamble length limit checking.
	1	Enable preamble length limit checking (12 bytes or less only).
0	0	Disable preamble checking.
	1	Enable preamble checking.



<b>Network Port B Gap 0 Register (NBG0R) (Address = 0x0244)</b>		
<b>Bit(s)</b>	<b>Value</b>	<b>Description</b>
7		This bit is ignored and will always return zero when read.
6:0		Back-to-back interpacket gap. Recommended values are 0x15 for full-duplex operation, and 0x12 for half-duplex operation. These values result in 9.6 $\mu$ s for 10 Mbits/s and 0.96 $\mu$ s for 100 Mbits/s, as specified by 802.3.

<b>Network Port B Gap 2 Register (NBG2R) (Address = 0x0246)</b>		
<b>Bit(s)</b>	<b>Value</b>	<b>Description</b>
7		This bit is ignored and will always return zero when read.
6:0		Non-back-to-back interpacket gap for carrier deference. Recommended value is 0x0C, as specified by 802.3.

<b>Network Port B Gap 1 Register (NBG1R) (Address = 0x0247)</b>		
<b>Bit(s)</b>	<b>Value</b>	<b>Description</b>
7		This bit is ignored and will always return zero when read.
6:0		Non-back-to-back interpacket gap. Recommended value is 0x12. This value results in 9.6 $\mu$ s for 10 Mbits/s and 0.96 $\mu$ s for 100 Mbits/s, as specified by 802.3.

<b>Network Port B Retransmit Max Register (NBRMR) (Address = 0x0248)</b>		
<b>Bit(s)</b>	<b>Value</b>	<b>Description</b>
7:4		These bits are ignored and will always return zero when read.
3:0		Number of retransmission attempts after a collision before aborting. Default (and value specified by 802.3) is 0xF.

<b>Network Port B Collision Window Register (NBCWR) (Address = 0x0249)</b>		
<b>Bit(s)</b>	<b>Value</b>	<b>Description</b>
7:6		These bits are ignored and will always return zero when read.
5:0		Collision window (slot time). Default (and value specified by 802.3) is 0x37.

<b>Network Port B Frame Limit LSB Register (NBFLLR) (Address = 0x024A)</b>		
<b>Bit(s)</b>	<b>Value</b>	<b>Description</b>
7:0		LSB of maximum frame length.

<b>Network Port B Frame Limit MSB Register (NBFLMR) (Address = 0x024B)</b>		
<b>Bit(s)</b>	<b>Value</b>	<b>Description</b>
7:0		MSB of maximum frame length. Default (and value specified by 802.3) is 0x0600.(1536), including preamble, address, length, and CRC fields. Should not be less than 0x05EE (1518) for normal operation.

<b>Network Port B MII Configuration Register (NBMCFR) (Address = 0x0250)</b>		
<b>Bit(s)</b>	<b>Value</b>	<b>Description</b>
7:5		These bits are ignored and will always return zeros when read.
4:2	000	MII Management Clock is system clock divided by 4.
	001	This value is reserved and should not be used.
	010	MII Management Clock is system clock divided by 6.
	011	MII Management Clock is system clock divided by 8.
	100	MII Management Clock is system clock divided by 10.
	101	MII Management Clock is system clock divided by 14.
	110	MII Management Clock is system clock divided by 20.
	111	MII Management Clock is system clock divided by 28.
1	0	Enable MII frame preambles.
	1	Disable MII frame preambles.
0	0	Disable MII scan function.
	1	Enable MII scan function.

<b>Network Port B MII Reset Register (NBMR) (Address = 0x0251)</b>		
<b>Bit(s)</b>	<b>Value</b>	<b>Description</b>
7	0	No operation.
	1	Reset the MII management module.
6:0		These bits are ignored and will always return zeros when read.

<b>Network Port B MII Command Register (NBMCR) (Address = 0x0252)</b>		
<b>Bit(s)</b>	<b>Value</b>	<b>Description</b>
7:2		These bits are ignored and will always return zeros when read.
1	0	No operation.
	1	Enable scan. MII module performs continuous read cycles.
0	0	No operation.
	1	Perform one MII read cycle.

<b>Network Port B MII Register Address Register (NBMRAR) (Address = 0x0254)</b>		
<b>Bit(s)</b>	<b>Value</b>	<b>Description</b>
7:5		These bits are ignored and will always return zeros when read.
4:0		MII register address.

<b>Network Port B MII PHY Address Register (NBMPAR) (Address = 0x0255)</b>		
<b>Bit(s)</b>	<b>Value</b>	<b>Description</b>
7:5		These bits are ignored and will always return zeros when read.
4:0		MII PHY address.

<b>Network Port B MII Write LSB Register (NBMWLR) (Address = 0x0256)</b>		
<b>Bit(s)</b>	<b>Value</b>	<b>Description</b>
7:0		LSB of MII write data.

<b>Network Port B MII Write MSB Register (NBMWMR) (Address = 0x0257)</b>		
<b>Bit(s)</b>	<b>Value</b>	<b>Description</b>
7:0		MSB of MII write data. Writing to this register triggers an MII write cycle.

<b>Network Port B MII Read LSB Register (NBMRLR) (Address = 0x0258)</b>		
<b>Bit(s)</b>	<b>Value</b>	<b>Description</b>
7:0		LSB of MII read data.

<b>Network Port B MII Read MSB Register (NBMRMR) (Address = 0x0259)</b>		
<b>Bit(s)</b>	<b>Value</b>	<b>Description</b>
7:0		MSB of MII read data.

<b>Network Port B MII Status Register (NBMSR) (Address = 0x025A)</b>		
<b>Bit(s)</b>	<b>Value</b>	<b>Description</b>
7:4		These bits are ignored and will always return zeros when read.
3	0	MII link okay.
	1	MII link fail.
2	0	MII read data valid.
	1	MII read data not valid.
1	0	MII not busy scanning.
	1	MII scan operation in progress.
0	0	MII not busy performing a read or write cycle.
	1	MII busy performing a read or write cycle.

<b>Network Port B Station Address x Register (NBSA0R) (Address = 0x0260)</b>		
<b>(NBSA1R) (Address = 0x0261)</b>		
<b>(NBSA2R) (Address = 0x0262)</b>		
<b>(NBSA3R) (Address = 0x0263)</b>		
<b>(NBSA4R) (Address = 0x0264)</b>		
<b>(NBSA5R) (Address = 0x0265)</b>		
<b>Bit(s)</b>	<b>Value</b>	<b>Description</b>
7:0		Byte of physical address for transmit control frames.

<b>Enable Network Port Register (ENPR) (Address = 0x0430)</b>		
<b>Bit(s)</b>	<b>Value</b>	<b>Description</b>
7:6	00	Disable both Network Port B and Network Port C.
	01	Enable Network Port B (the 10/100Base-T Ethernet port).
	10	Enable Network Port C (the Wi-Fi port). This bit combination is forced whenever either SCFG pin is high.*
	11	This bit combination is reserved and must not be used.
5:2	0	These bits are reserved and should be written with zeros.
1:0	00	Network Port C interrupts are disabled.
	01	Network Port C interrupts use Interrupt Priority 1.
	10	Network Port C interrupts use Interrupt Priority 2.
	11	Network Port C interrupts use Interrupt Priority 3.

\* Customers wishing to incorporate the Wi-Fi peripheral in their own design should contact Rabbit for more information.



## 23. 802.11B/G WIRELESS

### 23.1 Overview

Network Port C implements an 802.11b/g compatible wireless LAN radio. It consists of a baseband processor, high-speed A/D and D/A converters, and an interface for one of several external radio-frequency (RF) transceivers. The external transceiver is responsible for the up-conversion and down-conversion of the RF signal.

The receiver and transmitter each have a 2048-byte FIFO that is shared with the Ethernet peripheral; the I/O pins are also shared. Because of this, only one of the two network peripherals can be enabled at any particular time.

Communication with the external transceiver is accomplished through a 3-wire serial interface. Support is also provided for a parallel automatic gain control feedback loop. Control for multiple antennas is available, providing support for separate receive and transmit antennas or switched antenna diversity reception.

The MAC processing is handed by a combination of the baseband processor and software on the Rabbit; any timing-critical MAC operations are handled automatically by the baseband. These operations include time management and transmission-interval spacing. The MAC also performs the CRC check of all received frames and handles the virtual carrier sense functionality.

The Rabbit 5000 supports both the infrastructure and the ad-hoc modes. Multicast transmissions are supported as well.

The external interface to the external transceiver consists of 20 digital pins and 8 analog pins. A 20 MHz clock is required as an input. A separate low-speed A/D converter is available to monitor the transmit power via software.

The wireless peripheral also contains an AES encryption/decryption engine for both transmitted and received packets. Up to four expanded keys can be stored in the peripheral at one time.

### 23.1.1 Block Diagram

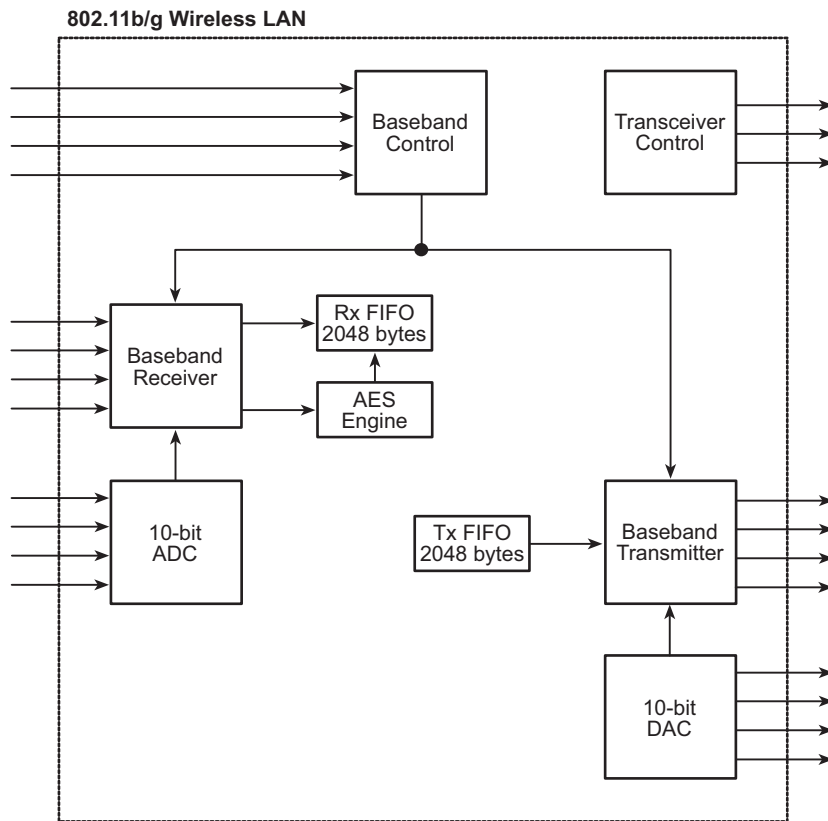



## 23.1.2 Registers

Register Name	Mnemonic	I/O Address	R/W	Reset
Enable Network Port Register	ENPR	0x0430	R/W	00000000
Network Port C Version 0 Register	NCV0R	0x0A00	R	00000000
Network Port C Version 1 Register	NCV1R	0x0A01	R	00000001
Network Port C General Control 0 Register	NCGC0R	0x0A04	R/W	00000000
Network Port C General Control 1 Register	NCGC1R	0x0A05	R/W	01000000
Network Port C General Control 2 Register	NCGC2R	0x0A06	R/W	01111111
Network Port C General Control 3 Register	NCGC3R	0x0A07	R	00110111
Network Port C General Status 0 Register	NCGS0R	0x0A08	R	00010000
Network Port C General Status 1 Register	NCGS1R	0x0A09	R/W	00000000
Network Port C General Status 2 Register	NCGS2R	0x0A0A	R/W	00000000
Network Port C General Status 3 Register	NCGS3R	0x0A0B	R/W	00110000
Network Port C RSSI 0 Register	NCRSSI0R	0x0A0C	R	01111111
Network Port C RSSI 1 Register	NCRSSI1R	0x0A0D	R	00000000
Network Port C RSSI 2 Register	NCRSSI2R	0x0A0E	R	00000000
Network Port C RSSI 3 Register	NCRSSI3R	0x0A0F	R	00000000
Network Port C Interrupt Mask Register	NCIMR	0x0A10	R/W	00000000
Network Port C Interrupt Status Register	NCISR	0x0A14	R/W	00000000
Network Port C SPI Data 0 Register	NCSPID0R	0x0A18	W	00000000
Network Port C SPI Data 1 Register	NCSPID1R	0x0A19	W	00000000
Network Port C SPI Data 2 Register	NCSPID2R	0x0A1A	W	00000000
Network Port C SPI Data 3 Register	NCSPID3R	0x0A1B	W	00000000
Network Port C SPI Control Register	NCSPICR	0x0A1C	R/W	00011000
Network Port C Data FIFO 0 Register	NCDFR	0x0A20	R/W	00000000
Network Port C Configuration-1 Register 0	NCC1R0	0x0A28	R/W	00101100
Network Port C Configuration-1 Register 1	NCC1R1	0x0A29	R/W	00000000
Network Port C Configuration-1 Register 2	NCC1R2	0x0A2A	R/W	01000011
Network Port C Configuration-1 Register 3	NCC1R3	0x0A2B	R/W	10000000
Network Port C Configuration-2 Register 0	NCC2R0	0x0A2C	R/W	00010100
Network Port C Configuration-2 Register 1	NCC2R1	0x0A2D	R/W	10110011
Network Port C Configuration-2 Register 2	NCC2R2	0x0A2E	R/W	10000010
Network Port C Configuration-2 Register 3	NCC2R3	0x0A2F	R/W	00001000
Network Port C AES FIFO Register	NCAFR	0x0A30	R/W	xxxxxxxx

Register Name	Mnemonic	I/O Address	R/W	Reset
Network Port C AES Mode Register	NCAMR	0x0A38	R/W	00000000
Network Port C Output Control Register 0	NCOCR0	0x0A3C	R/W	00000001
Network Port C Output Control Register 1	NCOCR1	0x0A3D	R/W	00000000
Network Port C Output Control Register 2	NCOCR2	0x0A3E	R/W	00000000
Network Port C Output Control Register 3	NCOCR3	0x0A3F	R/W	00000000
Network Port C Station ID x Register	NCSTAI DxR	0x0A40–0x0A45	R/W	xxxxxxx
Network Port C BSS ID x Register	NCBSSIDxR	0x0A48–0x0A4D	R/W	xxxxxxx
Network Port C OFDM Basic Rate Set Register	NCOFDMBSR	0x0A50	R/W	xxxxxxx
Network Port C PSK Basic Rate Set Register	NCPSKBSR	0x0A51	R/W	xxxxxxx
Network Port C SSID Length Register	NCSSIDLR	0x0A53	R/W	xxxxxxx
Network Port C Backoff 0 Register	NCBO0R	0x0A56	R/W	xxxxxxx
Network Port C Backoff 1 Register	NCBO1R	0x0A57	R/W	xxxxxxx
Network Port C DTIM Period Register	NCDTIMPR	0x0A58	R/W	xxxxxxx
Network Port C CFP Period Register	NCCFP PR	0x0A59	R/W	xxxxxxx
Network Port C Listen Interval 0 Register	NCLI0R	0x0A5A	R/W	xxxxxxx
Network Port C Listen Interval 1 Register	NCLI1R	0x0A5B	R/W	xxxxxxx
Network Port C Beacon Interval 0 Register	NCBI0R	0x0A5C	R/W	xxxxxxx
Network Port C Beacon Interval 1 Register	NCBI1R	0x0A5D	R/W	xxxxxxx
Network Port C CFP Max Duration 0 Register	NCCFPMD0R	0x0A5E	R/W	xxxxxxx
Network Port C CFP Max Duration 1 Register	NCCFPMD1R	0x0A5F	R/W	xxxxxxx
Network Port C MAC Status Register	NCMACSR	0x0A6C	R/W	xxxxxxx
Network Port C MAC Control Register	NCMACCR	0x0A67	R/W	xxxxxxx
Network Port C Remaining Backoff 0 Register	NCRBO0R	0x0A6A	R/W	xxxxxxx
Network Port C Remaining Backoff 1 Register	NCRBO1R	0x0A6B	R/W	xxxxxxx
Network Port C Beacon Filter Register	NCBFR	0x0A6D	R/W	xxxxxxx
Network Port C Beacon Backoff 0 Register	NCBBO0R	0x0A6E	R/W	xxxxxxx
Network Port C Beacon Backoff 1 Register	NCBBO1R	0x0A6F	R/W	xxxxxxx

## 23.2 Dependencies

### 23.2.1 I/O Pins

The wireless network port interface has 28 dedicated pins, as shown in Table 23-1. Of those, 20 are digital and can be used as general-purpose I/O via NBDRR, NBDTR, and NBDMR if the network port is not being used.

**Table 23-1. Wireless Port Interface**

Block	Section	Signal	Direction	Function
Analog	Input	VINQP	Input	Q channel differential input
		VINQN	Input	
		VINIP	Input	I channel differential input
		VININ	Input	
	Output	VOUTPQ	Output	Q channel differential output
		VOUTNQ	Output	
		VOUTPI	Output	I channel differential output
		VOUTNI	Output	
	Clock	CLK_IN	Input	20 MHz clock input
	Digital	Auto Gain Correction	VGA[4:0]	Output
LNA[1:0]			Output	Linear amplifier setting
Control		TX_ON	Output	Transmit enable
		RX_ON	Output	Receive enable
		LOCK	Input	Transceiver PLL lock input
		RXHP	Output	Reserved for future use, may be used as a general-purpose output
		ANT_SEL	Output	Antenna select enable
		/ANT_SEL	Output	Antenna select enable
		PA2G_ON	Output	2G preamplifier enable
		PA5G_ON	Output	5G preamplifier enable
		ACT_LED	Output	Activity LED control
		BOOTMUX	Output	General-purpose output
Management		SCLK	Output	3-wire serial clock
		SDATA	Output	3-wire serial data
		/SEN	Output	3-wire serial enable

## 23.3 Clocks

The wireless network port requires a 20 MHz clock input at CLK\_IN for proper operation.

### 23.3.1 Other Registers

Register	Function
EDMR	Enable Wi-Fi functionality.
NCWR	Set Network Port C wait states (0–15).

### 23.3.2 Interrupts

The wireless network interrupt can be generated for any of the following reasons.

- When data are available in the receive FIFO.
- When the transmit FIFO becomes empty.
- When a receive timeout occurs.
- When a transmit abort occurs.
- When an Announcement Traffic Indication Message (ATIM) is received.
- When the receive FIFO is overrun.
- When a complete packet is received.

The events that generate an interrupt can be selected in NCISR.

The wireless network port interrupt vector is shared with the Ethernet network port. It is located in the IIR at offset 0x1E0. It can be set as Priority 1, 2, or 3 by writing to ENPR.

## 23.4 Operation

At the present time, the wireless peripheral is intended to be used only in Rabbit-branded and other products offered by Digi International. The information provided in the *Rabbit 5000 Microprocessor User's Manual* should be sufficient to explain the operation of the wireless peripheral in these products. Customers wishing to incorporate the wireless peripheral in their own design should contact Rabbit for more information.

## 24. INPUT CAPTURE

### 24.1 Overview

The input capture peripheral consists of two channels, each of which contains a 16-bit counter and edge-detection circuitry. The input capture channels are usually used to determine the time between events. An event is signaled by a rising or falling edge (or optionally by either edge) on one of 12 input pins that can be selected as the input for either of the two channels. A digital low-pass filter is present on the inputs, as explained in Section 24.2.4.

Each channel can be used in one of two modes—input capture or input count. In the input-capture mode, the channel starts/stops the counter (clocked by Timer A8) according to the signal edges on various parallel port pins, providing the ability to measure pulse widths and time intervals between external events, time-stamp signal changes on a pin, and measure time intervals between a software start and an external event. An interrupt can also be generated when an edge is detected or when a counter rolls over

In the input-count mode the channel simply increments the counter each time a desired edge is detected. The start condition is enabled by the first Timer A8 clock after the mode is selected and the stop condition generated when the count matches the value written into the counter registers; this allows an interrupt to be generated when a particular count is reached.

A 16 bit counter is used to record the time at which the event takes place. The counter is driven by the output of Timer A8 and can be set to count at a rate ranging from the full clock speed ( $\text{perclk}/2$ ) down to  $1/256$  the clock speed ( $\text{perclk}/512$ ).

Two events are recognized: a *start condition* and a *stop condition*. The start condition may be used to start counting and the stop condition to stop counting. However, the counter may also run continuously or run until a stop condition is encountered. The start and stop conditions may also be used to latch the current time at the instant the condition occurs rather than actually start or stop the counter. The same pin may be used to detect the start and stop condition—for example a rising edge could be the start condition and a falling edge could be the stop condition. The start and stop condition can also be the input from separate pins.

The input capture channels can be used to measure the width of fast pulses. This is done by starting the counter on the first edge of the pulse and capturing the counter value on the second edge of the pulse. In this case the maximum error in the measurement is approximately 2 periods of the clock used to count the counter. If there is sufficient time between events for an interrupt to take place the unit can be set up to capture the counter value on

either start or stop conditions (or both) and cause an interrupt each time the count is captured. The counter can also be cleared and started under software control and then have its value captured in response to an input.

The capture counter can be synchronized with Timer B outputs to load parallel port output registers. This makes it possible to generate an output signal precisely synchronized with an input signal. Usually it will be desired to synchronize one of the input capture counters with the Timer B counter. The count offset can be measured by outputting a pulse at a precise time using Timer B to set the output time and capturing the output pulse with an input capture channel. Once the phase relationship is known between the counters it is then possible to output pulses a precise time delay after an input pulse is captured, provided that the time delay is great enough for the interrupt routine to process the capture event and set up the output pulse synchronized by Timer B. The minimum time delay needed is probably less than 10  $\mu$ s if the software is done carefully and the clock speed is reasonably high.

### 24.1.1 Block Diagram

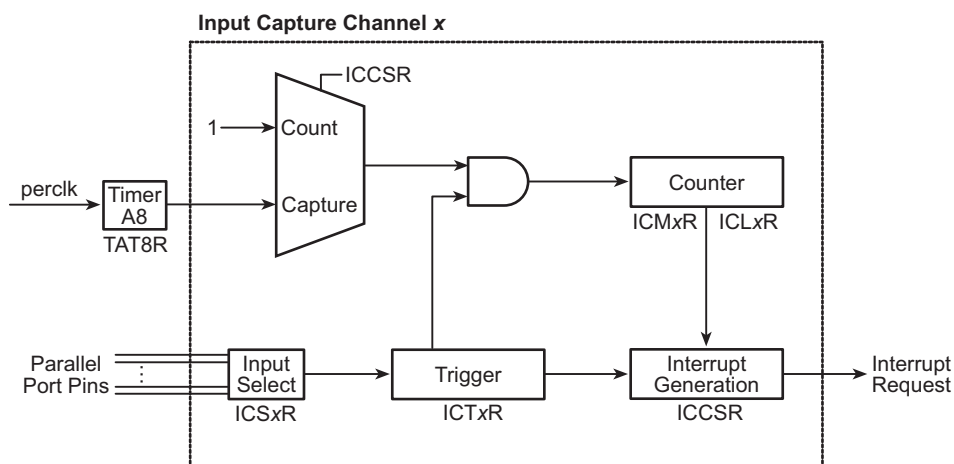

## 24.1.2 Registers

Register Name	Mnemonic	I/O Address	R/W	Reset
Input Capture Ctrl/Status Register	ICCSR	0x0056	R/W	00000000
Input Capture Control Register	ICCR	0x0057	W	00000000
Input Capture Trigger 1 Register	ICT1R	0x0058	R/W	00000000
Input Capture Source 1 Register	ICS1R	0x0059	R/W	xxxxxxxx
Input Capture LSB 1 Register	ICL1R	0x005A	R	xxxxxxxx
Input Capture MSB 1 Register	ICM1R	0x005B	R	xxxxxxxx
Input Capture Trigger 2 Register	ICT2R	0x005C	R/W	00000000
Input Capture Source 2 Register	ICS2R	0x005D	R/W	xxxxxxxx
Input Capture LSB 2 Register	ICL2R	0x005E	R	xxxxxxxx
Input Capture MSB 2 Register	ICM2R	0x005F	R	xxxxxxxx

## 24.2 Dependencies

### 24.2.1 I/O Pins

Each input-capture channel can accept input from one of the following parallel port pins: PC1, PC3, PC5, PC7, PD1, PD3, PD5, PD7, PE1, PE3, PE5, PE7. Use ICTxR to select which input pin to trigger on.

Note that these pins can be used for other peripherals at the same time as the input-capture peripheral. For example, you can use input capture to use measure the pulse width on a serial port input to measure the baud rate.

### 24.2.2 Clocks

The 16-bit input-capture counters are clocked from the output of Timer A8, and can run at rates from  $\text{perclk}/2$  down to  $\text{perclk}/512$  by writing the appropriate value to TAT8R.

### 24.2.3 Other Registers

Register	Function
TAT8R	Time constant for input-capture clock.

### 24.2.4 Interrupts

Each input capture channel can generate an interrupt whenever a start/stop condition occurs. The interrupt request is cleared when ICCSR is read.

The input capture interrupt vector is in the IIR at offset 0x1A0. It can be set as Priority 1, 2, or 3.

The input-capture channels synchronize their inputs to the peripheral clock (further divided by Timer A8). Since the inputs are only sampled in synch with the peripheral clock, any faster state faster changes cannot be detected, which is akin to a digital low-pass filter functionality on the inputs. Because of this, there is some delay between the input transition and when an interrupt is requested, as shown below. The status bits in ICSxR are set coincident with the interrupt request and are reset when read from the ICSxR.

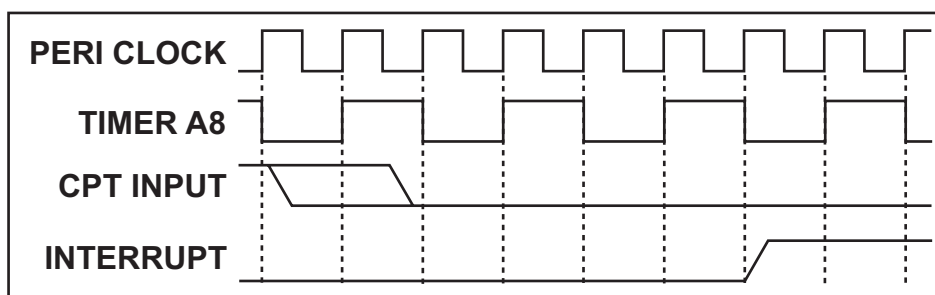



## 24.3 Operation

### 24.3.1 Input-Capture Channel

The following steps explain how to set up an input-capture channel.

1. Configure Timer A8 via TAT8R to provide the desired input-capture clock.
2. Configure ICTxR to provide the desired start/stop operation and conditions.
3. Configure ICSxR to select the input pins for the start and stop conditions.
4. Configure ICCR to select either the count or the capture mode.
5. Reset the counter by writing to ICCSR.

### 24.3.2 Handling Interrupts

The following steps explain how an interrupt is used.

1. Write the vector to the interrupt service routine to the internal interrupt table
2. Configure the Input Capture Control/Status Register (ICCSR) to select events that will generate an interrupt.
3. Configure the Input Capture Control Register (ICCR) to select the interrupt priority (note that interrupts will be enabled once this value is set; this step should be done last).

The following actions occur within the interrupt service routine.

- If needed, the current counter value can be read from ICLxR and LCMxR (reading from ICLxR latches the value of ICLxR, so ICLxR should always be read first)
- If the counter is expected to roll over, determine if that is why the interrupt occurred by reading the status bits in ICCSR and adjusting any software counters accordingly
- The interrupt request should be cleared by reading from ICCSR

### 24.3.3 Example ISR

A sample interrupt handler is shown below.

```
ic_isr:
    push af
    ioi ld a, (ICCSR)    ; clear the interrupt request and get status
    ; determine which interrupts have occurred
    ; if rollover, perform any necessary software counter adjustments here
    ; read counter values
    pop af
    ipres
    ret
```

## 24.3.4 Capture Mode

### Pulse Width or Time Between Events

The following steps explain how to measure the pulse width or time between events.

1. Select the same input pin to perform a pulse-width measurement between the start and stop conditions, or select two different input pins to measure time between events on those pins.
2. Set the counter to start on the start condition and stop on the stop condition, latch on the stop condition, and generate an interrupt on the stop condition.
3. In the interrupt handler, read out the counter to determine the pulse width or time interval between the two events.

### Time-Stamp External Events

The following steps explain how to time-stamp external events.

1. Set the trigger for the desired event type.
2. Set the counter to run continuously, latch on the start (and/or stop) condition, and generate an interrupt on the start (and/or stop) condition
3. In the interrupt handler, read out the counter as an event timestamp.

### Measure Time Interval from a Software Start to an External Event

The following steps explain how to measure the time interval between a software start and the occurrence of an external event.

1. Set up the counter to run continuously, latch on the stop condition, and generate an interrupt on the stop condition.
2. Set up the stop condition for the event of interest.
3. Reset the counter via ICCSR at the software start.
4. In the interrupt handler, read the counter as a time duration.

## 24.3.5 Count Mode

The following steps explain how to count pulses.

1. Set the counter to run continuously until the stop condition occurs and to latch on the start condition.
2. If an interrupt is desired at a particular count, write that value into the LSB and MSB registers.
3. Set the start condition for the pulse type desired.
4. Reset the counter by writing to ICCSR.
5. Reading the counter at any time will give the current count.

## 24.4 Register Descriptions

Input Capture Control/Status Register		(ICCSR)	(Address = 0x0056)
Bit(s)	Value	Description	
7 (Read)	0	The Input Capture 2 Start condition has not occurred.	
	1	The Input Capture 2 Start condition has occurred.	
6 (Read)	0	The Input Capture 2 Stop condition has not occurred.	
	1	The Input Capture 2 Stop condition has occurred.	
5 (Read)	0	The Input Capture 1 Start condition has not occurred.	
	1	The Input Capture 1 Start condition has occurred.	
4 (Read)	0	The Input Capture 1 Stop condition has not occurred.	
	1	The Input Capture 1 Stop condition has occurred.	
3 (Read)	0	The Input Capture 2 counter has not rolled over to all zeros.	
	1	The Input Capture 2 counter has rolled over to all zeros.	
2 (Read)	0	The Input Capture 1 counter has not rolled over to all zeros.	
	1	The Input Capture 1 counter has rolled over to all zeros.	
7:2 (Read)		These status bits (but not the interrupt enable bits) are cleared by the read of this register, as is the Input Capture Interrupt.	
7:4 (Write)	0	The corresponding Input Capture interrupt is disabled.	
	1	The corresponding Input Capture interrupt is enabled.	
3 (Write)	0	No effect on Input Capture 2 counter. This bit always reads as zero.	
	1	Reset Input Capture 2 counter to all zeros and clears the rollover latch.	
2 (Write)	0	No effect on Input Capture 1 counter. This bit always reads as zero.	
	1	Reset Input Capture 1 counter to all zeros and clears the rollover latch.	
1:0		These bits are reserved and should be written with zeros. These bits will always be read as zeros.	

<b>Input Capture Control Register (ICCR) (Address = 0x0057)</b>		
<b>Bit(s)</b>	<b>Value</b>	<b>Description</b>
7	0	Input Capture operation for Input Capture 2.
	1	Input Count operation for Input Capture 2.
6	0	Input Capture operation for Input Capture 1.
	1	Input Count operation for Input Capture 1.
5:2		These bits are reserved and should be written with zero.
1:0	00	Input Capture interrupts are disabled.
	01	Input Capture interrupt use Interrupt Priority 1.
	10	Input Capture interrupt use Interrupt Priority 2.
	11	Input Capture interrupt use Interrupt Priority 3.

<b>Input Capture Trigger x Register</b>		
		<b>(ICT1R) (ICT2R)</b>
		<b>(Address = 0x0058) (Address = 0x005C)</b>
<b>Bit(s)</b>	<b>Value</b>	<b>Description</b>
7:6	00	Disable the counter. Applies even in Counter operation.
	01	The counter runs from the Start condition until the Stop condition.
	10	The counter runs continuously.
	11	The counter runs continuously, until the Stop condition.
5:4	00	Disable the count latching function. In this case, and with Counter operation only, the ICLxR and ICMxR return the programmed match value.
	01	Latch the count on the Stop condition only.
	10	Latch the count on the Start condition only.
	11	Latch the count on either the Start or Stop condition.
3:2	00	Ignore the starting input.
	01	The Start condition is the rising edge of the starting input.
	10	The Start condition is the falling edge of the starting input.
	11	The Start condition is either edge of the starting input.
1:0	00	Ignore the ending input. These two bits are ignored in Counter operation.
	01	The Stop condition is the rising edge of the ending input.
	10	The Stop condition is the falling edge of the ending input.
	11	The Stop condition is either edge of the ending input.

<b>Input Capture Source x Register</b>			<b>(ICS1R)</b>	<b>(Address = 0x0059)</b>
			<b>(ICS2R)</b>	<b>(Address = 0x005D)</b>
<b>Bit(s)</b>	<b>Value</b>	<b>Description</b>		
7:6	00	Parallel Port C used for Start condition input.		
	01	Parallel Port D used for Start condition input.		
	10	Parallel Port E used for Start condition input.		
	11	This bit combination is reserved and should not be used.		
5:4	00	Use port bit 1 for Start condition input.		
	01	Use port bit 3 for Start condition input.		
	10	Use port bit 5 for Start condition input.		
	11	Use port bit 7 for Start condition input.		
3:2	00	Parallel Port C used for Stop condition input.		
	01	Parallel Port D used for Stop condition input.		
	10	Parallel Port E used for Stop condition input.		
	11	This bit combination is reserved and should not be used.		
1:0	00	Use port bit 1 for Stop condition input.		
	01	Use port bit 3 for Stop condition input.		
	10	Use port bit 5 for Stop condition input.		
	11	Use port bit 7 for Stop condition input.		

<b>Input Capture LSB x Register</b>			<b>(ICL1R)</b>	<b>(Address = 0x005A)</b>
			<b>(ICL2R)</b>	<b>(Address = 0x005E)</b>
<b>Bit(s)</b>	<b>Value</b>	<b>Description</b>		
7:0	Read	The least significant eight bits of the latched Input Capture count are returned. Reading the LSB of the count latches the MSB of the count to avoid reading stale data. Reading the MSB of the count opens these latches on the MSB of the count. In Counter operation, if no latching condition is specified the value written to this register is returned.		
	Write	The eight LSBs of the match value for counter mode are stored.		

<b>Input Capture MSB x Register</b>			<b>(ICM1R)</b>	<b>(Address = 0x005B)</b>
			<b>(ICM2R)</b>	<b>(Address = 0x005F)</b>
<b>Bit(s)</b>	<b>Value</b>	<b>Description</b>		
7:0	Read	The most significant eight bits of the latched Input capture count are returned. In Counter operation, if no latching condition is specified the value written to this register is returned.		
	Write	The eight MSBs of the match value for counter mode are stored.		





# 25. QUADRATURE DECODER

## 25.1 Overview

The Rabbit 5000 has a two-channel Quadrature Decoder that accepts inputs via specific pins on Parallel Ports D and E. Each channel has two inputs, the in-phase (I) input and the 90 degree or quadrature-phase (Q) input. An 8 or 10-bit up/down counter counts encoder steps in the forward and backward directions, and provides interrupts when the count goes from 0x00 to 0xFF or from 0xFF to 0x00. An interrupt can occur each time the count overflows or underflows. The Quadrature Decoder contains digital filters on the inputs to prevent false counts. The external signals are synchronized with an internal clock provided by the output of Timer A10.

Each Quadrature Decoder channel accepts inputs from either the upper nibble or lower nibble of Parallel Ports D and E. The I signal is input on an odd-numbered port bit, while the Q signal is input on an even-numbered port bit. There is also a disable selection, which is guaranteed not to generate a count increment or decrement on either entering or exiting the disabled state.

The operation of the counter as a function of the I and Q inputs is shown below.

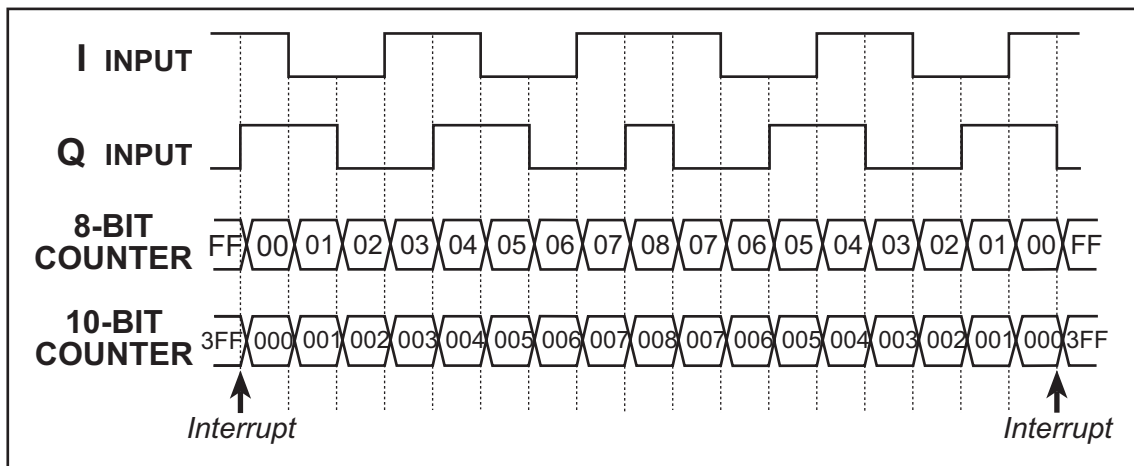

The Quadrature Decoders are clocked by the output of Timer A10, giving a maximum clock rate from  $\text{perclk}/2$  down to  $\text{perclk}/512$ . The time constant of Timer A10 must be fast enough to sample the inputs properly. Both the I and Q inputs go through a digital filter that rejects pulses shorter than two clock period wide. In addition, the clock rate must be high enough that transitions on the I and Q inputs are sampled in different clock cycles. Input capture may be used to measure the pulse width on the I inputs because they come from the odd-numbered port bits. The operation of the digital filter is shown below.

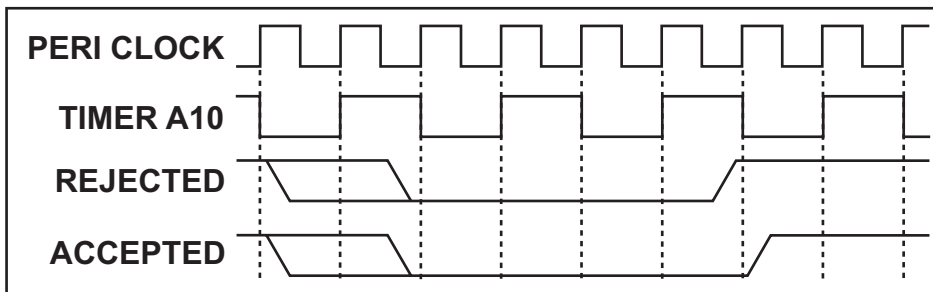

The Quadrature Decoder generates an interrupt when the counter increments from 0xFF (0x3FF in 10-bit mode) to 0x00, or when the counter decrements from 0x00 to 0xFF (0x3FF in 10-bit mode). The timing for the interrupt is shown below. Note that the status bits in the QDCSR are set coincident with the interrupt, and the interrupt and status bits are cleared by reading the QDCSR.

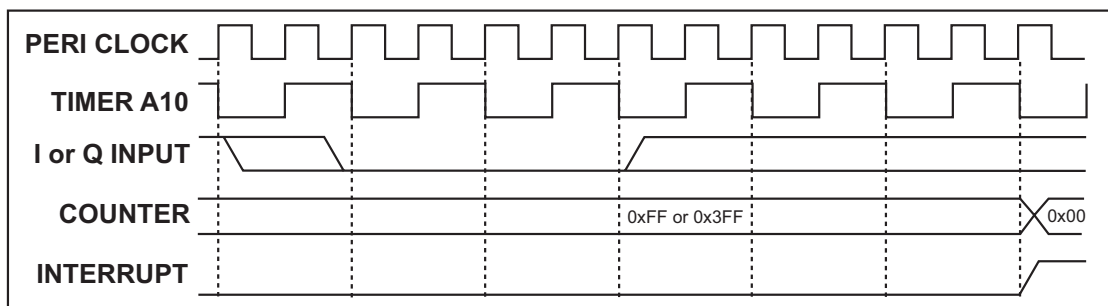

## 25.1.1 Block Diagram

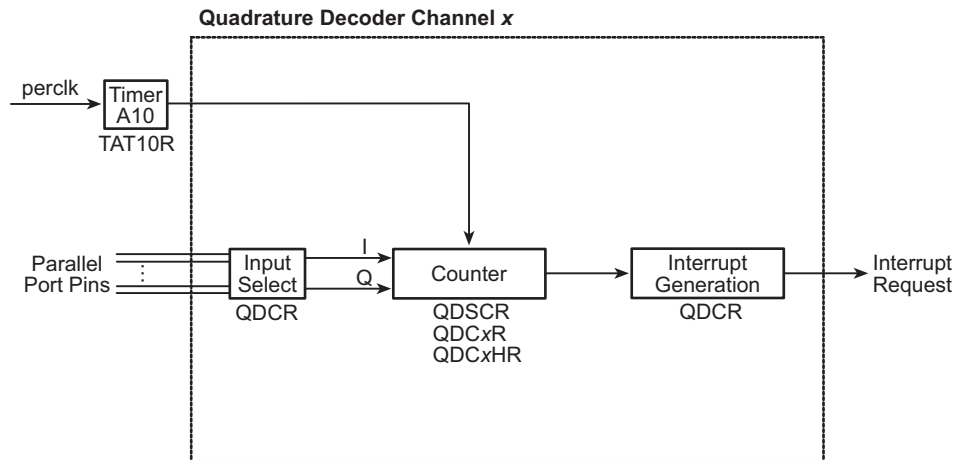

## 25.1.2 Registers

Register Name	Mnemonic	I/O Address	R/W	Reset
Quad Decode Ctrl/Status Register	QDCSR	0x0090	R/W	xxxxxxxx
Quad Decode Control Register	QDCR	0x0091	R/W	00000000
Quad Decode Count 1 Register	QDC1R	0x0094	R	xxxxxxxx
Quad Decode Count 1 High Register	QDC1HR	0x0095	R	xxxxxxxx
Quad Decode Count 2 Register	QDC2R	0x0096	R	xxxxxxxx
Quad Decode Count 2 High Register	QDC2HR	0x0097	R	xxxxxxxx

## 25.2 Dependencies

### 25.2.1 I/O Pins

Each Quadrature Decoder channel can accept the two encoder inputs from one of three different locations, as shown in the table below. Each channel can select a different input option. Note that these pins can be used for other peripherals at the same time as the Quadrature Decoder peripheral; one example of this use is to use measure pulse width on the I channels with the input capture peripheral.

Inputs	Channel 1		Channel 2	
	I	Q	I	Q
Option 1	PD1	PD0	PD3	PD2
Option 2	PE1	PE0	PE3	PE2
Option 3	PE5	PE4	PE7	PE6

### 25.2.2 Clocks

The 8/10-bit Quadrature Decoder counters are clocked from the output of Timer A10, and can run at rates from the peripheral clock divided by 2 down to the peripheral clock divided by 512 by writing the appropriate value to TAT10R. The clock rate must be high enough that transitions on the inputs are sampled in different clock cycles. In addition, both the I and Q inputs go through a digital filter that rejects pulses shorter than two clock periods wide.

### 25.2.3 Other Registers

Register	Function
TAT10R	Time constant for Quadrature Decoder clock

### 25.2.4 Interrupts

Each Quadrature Decoder channel can generate an interrupt whenever the counter increments from 0x0FF (0x3FF in 10-bit mode) to 0x00 or when the counter decrements from 0x000 to 0x0FF (0x3FF for 10-bit mode). The interrupt request is cleared when QDCSR is read.

The Quadrature Decoder interrupt vector is in the IIR at offset 0x190. It can be set as Priority 1, 2, or 3.

The status bits in the QDCSR are set coincident with the interrupt request and are reset when QDCSR is read.

## 25.3 Operation

The following steps explain how to set up a Quadrature Decoder channel.

1. Configure Timer A10 via TAT10R to provide the desired Quadrature Decoder clock speed.
2. Configure QDCR to select the input pins for the two channels.
3. Reset the counters by writing to QDCSR.

### 25.3.1 Handling Interrupts

The following steps explain how an interrupt is set up and used.

1. Write the vector to the interrupt service routine to the internal interrupt table.
2. Configure QDCR to select the interrupt priority (note that interrupts will be enabled once this value is set).

The following actions occur within the interrupt service routine.

- Since a Quadrature Decoder interrupt occurs when the counter rolls over, determine exactly why the interrupt occurred by reading the status bits in QDCSR and adjust any software counters accordingly. This will also clear the interrupt request.
- The current counter value can be read from QDCxR (and QDCxHR if the 10-bit counter is enabled).

### 25.3.2 Example ISR

A sample interrupt handler is shown below.

```
qd_isr:
    push af                ; save used registers
    iorl a, (QDCSR)       ; clear the interrupt request and get status

    ; perform any necessary software counter adjustments here
    ; read current counter value(s)

    pop af                ; restore used registers
    ipres
    ret
```

## 25.4 Register Descriptions

Quad Decode Control/Status Register (QDCSR) (Address = 0x0090)		
Bit(s)	Value	Description
7 (Read-only)	0	Quadrature Decoder 2 did not increment from the maximum count.
	1	Quadrature Decoder 2 incremented from the maximum count to 0x000. This bit is cleared by a read of his register.
6 (Read-only)	0	Quadrature Decoder 2 did not decrement from zero.
	1	Quadrature Decoder 2 decremented from zero to the maximum count. This bit is cleared by a read of this register.
5		This bit always reads as zero.
4 (Write-only)	0	No effect on the Quadrature Decoder 2.
	1	Reset Quadrature Decoder 2 to all zeros, without causing an interrupt.
3 (Read-only)	0	Quadrature Decoder 1 did not increment from the maximum count.
	1	Quadrature Decoder 1 incremented from the maximum count to zero. This bit is cleared by a read of this register.
2 (Read-only)	0	Quadrature Decoder 1 did not decrement from zero.
	1	Quadrature Decoder 1 decremented from zero to the maximum count. This bit is cleared by a read of this register.
1		This bit always reads as zero.
0 (Write-only)	0	No effect on the Quadrature Decoder 1.
	1	Reset Quadrature Decoder 1 to all zeros, without causing an interrupt.

<b>Quad Decode Control Register (QDCR) (Address = 0x0091)</b>		
<b>Bit(s)</b>	<b>Value</b>	<b>Description</b>
7:6	00	Disable Quadrature Decoder 2 inputs. Writing a new value to these bits will not cause Quadrature Decoder 2 to increment or decrement.
	01	Quadrature Decoder 2 inputs from Parallel Port D bits 3 and 2.
	10	Quadrature Decoder 2 inputs from Parallel Port E bits 3 and 2.
	11	Quadrature Decoder 2 inputs from Parallel Port E bits 7 and 6.
5	0	Eight bit quadrature decoder counters (both channels).
	1	Ten bit quadrature decoder counters (both channels).
4		This bit is reserved and should be written as zero.
3:2	00	Disable Quadrature Decoder 1 inputs. Writing a new value to these bits will not cause Quadrature Decoder 1 to increment or decrement.
	01	Quadrature Decoder 1 inputs from Parallel Port D bits 1 and 0.
	10	Quadrature Decoder 1 inputs from Parallel Port E bits 1 and 0.
	11	Quadrature Decoder 1 inputs from Parallel Port E bits 5 and 4.
1:0	00	Quadrature Decoder interrupts are disabled.
	01	Quadrature Decoder interrupt use Interrupt Priority 1.
	10	Quadrature Decoder interrupt use Interrupt Priority 2.
	11	Quadrature Decoder interrupt use Interrupt Priority 3.

<b>Quad Decode Count Register (QDC1R) (Address = 0x0094) (QDC2R) (Address = 0x0096)</b>		
<b>Bit(s)</b>	<b>Value</b>	<b>Description</b>
7:0	Read	The current value of bits 7-0 of the Quadrature Decoder counter is reported.

<b>Quad Decode Count High Register (QDC1HR) (Address = 0x0095) (QDC2HR) (Address = 0x0097)</b>		
<b>Bit(s)</b>	<b>Value</b>	<b>Description</b>
7:2	Read	These bits are reserved and will always read as zeros.
1:0	Read	The current value of bits 9-8 of the Quadrature Decoder counter is reported.





# 26. PULSE WIDTH MODULATOR

## 26.1 Overview

The Pulse Width Modulator (PWM) consists of a 10-bit free running counter and four width registers. A PWM output consists of a train of periodic pulses within a 1024-count frame with a duty cycle that varies from 1/1024 to 1024/1024. Each PWM output is high for  $n + 1$  counts out of the 1024-clock count cycle, where  $n$  is the value held in the width register. Any changes to the width registers will not take effect until the next counter roll-over. The PWM is clocked by the output of Timer A9 which is used to set the period.

Each PWM output high time can optionally be spread throughout the cycle to reduce ripple on the externally filtered PWM output. The PWM outputs can be passed through a filter and used as a 10-bit D/A converter. The outputs can also be used to directly drive devices such as motors or solenoids that have intrinsic filtering.

The PWM outputs can trigger a PWM interrupt on every PWM cycle, every other cycle, every fourth cycle, or every eighth cycle. In addition, the PWM output can be suppressed every other cycle, three out of every four cycles, or seven out of every eight cycles. These options provide support for driving servos and to generate audio signals. The setup for this interrupt is done in the PWL0R and PWL1R registers. The timing is shown below.

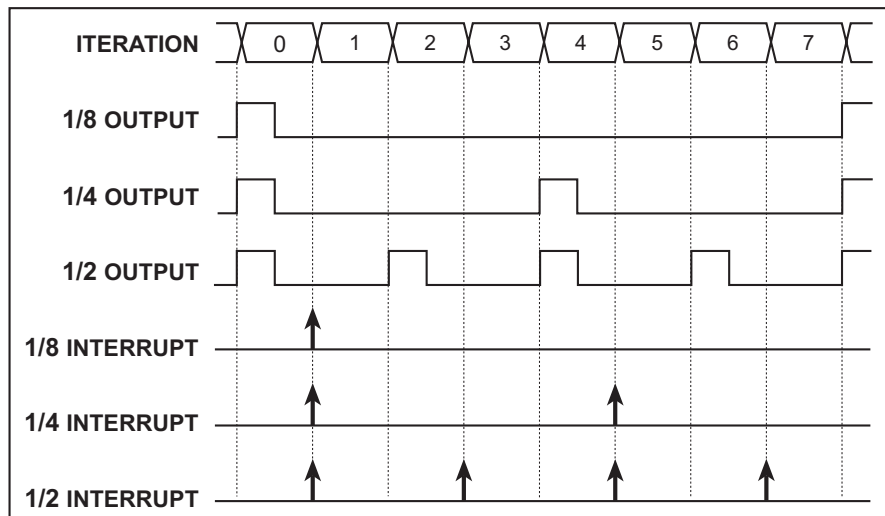

The spreading function is implemented by dividing each 1024-clock cycle into four quadrants of 256 clocks each. Within each quadrant, the Pulse-Width Modulator uses the eight MSBs of each pulse-width register to select the base width in each of the quadrants. This is the equivalent to dividing the contents of the pulse-width register by four and using this value in each quadrant. To get the exact high time, the Pulse-Width Modulator uses the two LSBs of the pulse-width register to modify the high time in each quadrant according to the table below. The “ $n/4$ ” term is the base count, formed from the eight MSBs of the pulse-width register.

Pulse-Width LSBs	1st	2nd	3rd	4th
00	$n/4 + 1$	$n/4$	$n/4$	$n/4$
01	$n/4 + 1$	$n/4$	$n/4 + 1$	$n/4$
10	$n/4 + 1$	$n/4 + 1$	$n/4 + 1$	$n/4$
11	$n/4 + 1$	$n/4 + 1$	$n/4 + 1$	$n/4 + 1$

The diagram below shows a PWM output for several different width values, for both modes of operation. Operation in the spread mode reduces the filtering requirements on the PWM output in most cases.

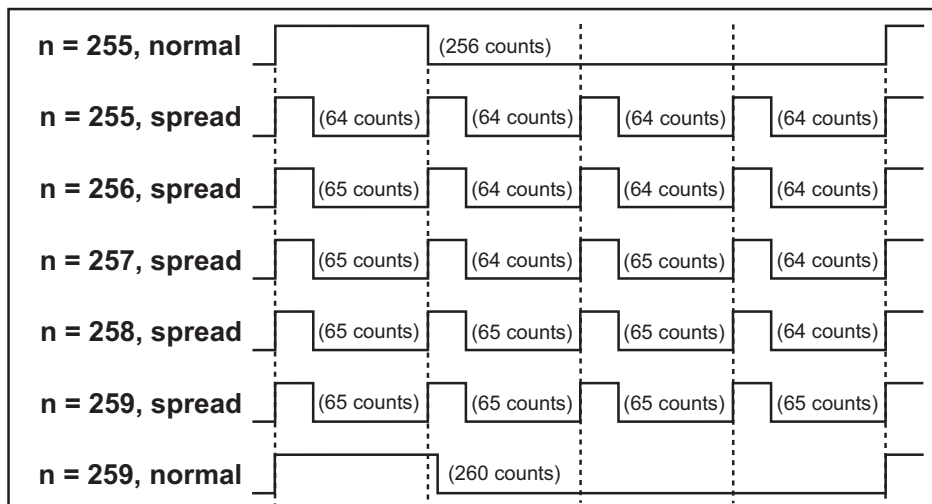

The DMA channels on the Rabbit 5000 are designed to work with fixed I/O addresses. To allow DMA control of the PWM, a separate PWM Block Access Register (PWBAR) and PWM Block Pointer Register (PWBPR) are available. The pointer register contains the address of the PWM register to be accessed via the access register. Each read or write of the access register automatically increments the pointer register through the sequence shown below. Note that only the lower three bits of the pointer register actually change. This allows the DMA to write to a fixed internal I/O location but still program all of the PWM registers. The pointer register can be written and read if necessary. Normally the

pointer register is initialized to 0x88 (the first PWM register) and the DMA then transfers blocks of eight bytes to completely reprogram the PWM.

0x88 -> 0x89 -> 0x8A -> 0x8B -> 0x8C -> 0x8D -> 0x8E -> 0x8F ->

When the DMA destination address is the PWBAR, the DMA request from the PWM is automatically connected to the DMA.

### 26.1.1 Block Diagram

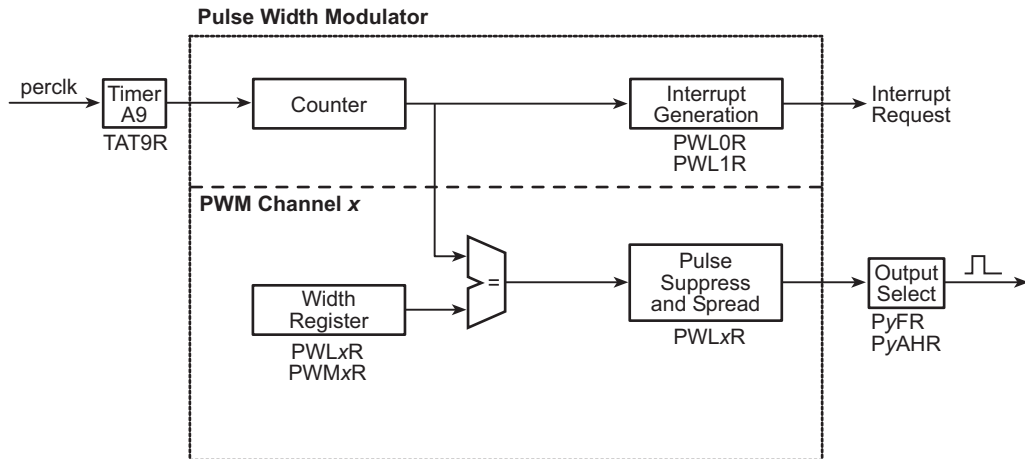

### 26.1.2 Registers

Register Name	Mnemonic	I/O Address	R/W	Reset
PWM LSB 0 Register	PWL0R	0x0088	R/W	xxxxx00x
PWM MSB 0 Register	PWM0R	0x0089	R/W	xxxxxxxx
PWM LSB 1 Register	PWL1R	0x008A	R/W	xxxxx00x
PWM MSB 1 Register	PWM1R	0x008B	R/W	xxxxxxxx
PWM LSB 2 Register	PWL2R	0x008C	R/W	xxxxx00x
PWM MSB 2 Register	PWM2R	0x008D	R/W	xxxxxxxx
PWM LSB 3 Register	PWL3R	0x008E	R/W	xxxxx00x
PWM MSB 3 Register	PWM3R	0x008F	R/W	xxxxxxxx
PWM Block Access Register	PWBAR	0x00E8	W	xxxxxxxx
PWM Block Pointer Register	PWBPR	0x00E9	W	10001000

## 26.2 Dependencies

### 26.2.1 I/O Pins

Each PWM channel can be output on up one of three pins, which can be selected via the parallel port alternate output registers.

PWM	Output Pins
Channel 0	PC4, PD4, PE4, PH4
Channel 1	PC5, PD5, PE5, PH5
Channel 2	PC6, PD6, PE6, PH6
Channel 3	PC7, PD7, PE7, PH7

### 26.2.2 Clocks

The PWM counter is clocked from the output of Timer A9, and can run at rates from  $\text{perclk}/2$  down to  $\text{perclk}/512$  by writing the appropriate value to TAT9R.

### 26.2.3 Other Registers

Register	Function
TAT9R	Time constant for PWM clock
PCFR, PCAHR PDFR, PDAHR PEFR, PEAHR PHFR, PHAHR	Alternate port output selection

### 26.2.4 Interrupts

The PWM can generate an interrupt for every PWM counter rollover, every second rollover, every fourth rollover, or every eighth rollover. This option is selected in PWL1R. The interrupt request is cleared by a write to any PWM register.

The PWM interrupt vector is in the IIR at offset 0x170. It can be set as Priority 1, 2, or 3 by writing to PWL0R.

## 26.3 Operation

The following steps explain how to set up a PWM channel.

1. Configure Timer A9 via TAT9R to provide the desired PWM clock frequency.
2. Configure PWLxR to select whether to spread the PWM output throughout the cycle.
3. Configure PWLxR to select whether to suppress the PWM output.
4. Configure the duty cycle by writing to PWLxR and PWMxR. Note that any changes to these registers while the PWM is active will not take effect until the next counter rollover.

### 26.3.1 Handling Interrupts

The following steps explain how an interrupt is set up and used.

1. Write the vector to the interrupt service routine to the internal interrupt table.
2. Configure PWL0R to select the PWM interrupt priority and PWL1R to select PWM interrupt suppression (if an interrupt is desired).

The following actions occur within the interrupt service routine.

- Any PWM values may be updated.
- The interrupt request should be cleared by writing to any PWM register.

### 26.3.2 Example ISR

A sample interrupt handler is shown below.

```
pwm_isr::
    push af                ; save used registers
    ld a, 0x55
    ioi ld (PWM0R), a     ; update a PWM value
    ; note that interrupt request is also cleared by register write above
    pop af                ; restore used registers
    ipres
    ret
```

## 26.4 Register Descriptions

PWM LSB 0 Register		(PWL0R)	(Address = 0x0088)
Bit(s)	Value	Description	
7:6		Least significant two bits for the Pulse Width Modulator count.	
5:4	00	Normal PWM operation.	
	01	Suppress PWM output seven out of eight iterations of PWM counter.	
	10	Suppress PWM output three out of four iterations of PWM counter.	
	11	Suppress PWM output one out of two iterations of PWM counter.	
3		This bit is ignored and should be written with zero.	
2:1	00	Pulse Width Modulator interrupts are disabled.	
	01	Pulse Width Modulator interrupts use Interrupt Priority 1.	
	10	Pulse Width Modulator interrupts use Interrupt Priority 2.	
	11	Pulse Width Modulator interrupts use Interrupt Priority 3.	
0	0	PWM output High for single block.	
	1	Spread PWM output throughout the cycle.	

PWM LSB 1 Register		(PWL1R)	(Address = 0x008A)
Bit(s)	Value	Description	
7:6		Least significant two bits for the Pulse Width Modulator count.	
5:4	00	Normal PWM operation.	
	01	Suppress PWM output seven out of eight iterations of PWM counter.	
	10	Suppress PWM output three out of four iterations of PWM counter.	
	11	Suppress PWM output one out of two iterations of PWM counter.	
3		This bit is ignored and should be written with zero.	
2:1	00	Normal PWM interrupt operation.	
	01	Suppress PWM interrupts seven out of eight iterations of PWM counter.	
	10	Suppress PWM interrupts three out of four iterations of PWM counter.	
	11	Suppress PWM interrupts one out of two iterations of PWM counter.	
0	0	PWM output High for single block.	
	1	Spread PWM output throughout the cycle.	

<b>PWM LSB x Register</b>			<b>(PWL2R)</b> <b>(PWL3R)</b>	<b>(Address = 0x008C)</b> <b>(Address = 0x008E)</b>
<b>Bit(s)</b>	<b>Value</b>	<b>Description</b>		
7:6		Least significant two bits for the Pulse Width Modulator count.		
5:4	00	Normal PWM operation.		
	01	Suppress PWM output seven out of eight iterations of PWM counter.		
	10	Suppress PWM output three out of four iterations of PWM counter.		
	11	Suppress PWM output one out of two iterations of PWM counter.		
3:1		These bits are ignored and should be written with zero.		
0	0	PWM output High for single block.		
	1	Spread PWM output throughout the cycle.		

<b>PWM MSB x Register</b>			<b>(PWM0R)</b> <b>(PWM1R)</b> <b>(PWM2R)</b> <b>(PWM3R)</b>	<b>(Address = 0x0089)</b> <b>(Address = 0x008B)</b> <b>(Address = 0x008D)</b> <b>(Address = 0x008F)</b>
<b>Bit(s)</b>	<b>Value</b>	<b>Description</b>		
7:0		Most significant eight bits for the Pulse Width Modulator count. With a count of “n”, the PWM output will be High for “n + 1” clocks out of the 1024 clocks of the PWM counter.		

<b>PWM Block Access Register</b>			<b>(PWBAR)</b>	<b>(Address = 0x00E8)</b>
<b>Bit(s)</b>	<b>Value</b>	<b>Description</b>		
7:0		Access the PWM register pointed to by the PWBPR. The PWBPR is automatically updated to the next PWM register address in the sequence.		

<b>PWM Block Pointer Register</b>			<b>(PWBPR)</b>	<b>(Address = 0x00E9)</b>
<b>Bit(s)</b>	<b>Value</b>	<b>Description</b>		
7:3		These bits are always read as 0x11.		
2:0		Three least significant bits of the PWM register address for indirect access.		







## 27. EXTERNAL I/O CONTROL

### 27.1 Overview

The Rabbit 5000's external I/O space consists of 64KB that is accessed by prefixing a read or write instruction with the **IOE** instruction. These accesses can go onto the memory bus or onto the external I/O bus (described below). There are three dedicated signal pins (**/IORD**, **/IOWR**, **/BUFEN**) that toggle for all external I/O accesses, and eight I/O strobes that can be associated with this external I/O space and directed out of Parallel Ports C, D, or E.

In addition, a handshaking signal input can be enabled on a Parallel Port E pin, and can be used to pause an external I/O transaction until the external device is ready to complete the transaction. A timeout period can be defined to ensure that the processor is not held indefinitely by a misbehaving external device.

#### 27.1.1 External I/O Bus

The Rabbit 5000 can enable a separate external I/O bus for external devices to keep bus loading on the memory bus at an acceptable level. This bus consists of eight data lines on Parallel Port A and up to eight address lines on Parallel Port B. This functionality is mutually exclusive with the slave port and regular parallel I/O on Parallel Ports A and B.

When enabled, the address lines of the external I/O bus hold their value until a new value is written to them. The data lines return to a tristate mode after each transaction.

See Section 27.1.2 for memory timing for external I/O accesses.

### 27.1.2 I/O Strobes

There are eight I/O strobes available in the Rabbit 5000. Each has a separate 8KB address range that can be enabled as a chip select, read strobe, write strobe, or a read/write strobe. The number of wait states can be set to 1, 3, 7, or 15, and the signal can be active high or low.

**Table 27-1. External I/O Strobes**

Register	External I/O Address Range
IB0CR	0x0000–0x1FFF
IB1CR	0x2000–0x3FFF
IB2CR	0x5000–0x5FFF
IB3CR	0x6000–0x7FFF
IB4CR	0x8000–0x9FFF
IB5CR	0xA000–0xBFFF
IB6CR	0xC000–0xDFFF
IB7CR	0xE000–0xFFFF

The I/O strobes can be used for devices on the memory bus or the external I/O bus, and can be enabled to go out on the memory bus alone or both buses. It is also possible to shorten the read strobe by one clock cycle and the write strobe by one-half a clock cycle by pulling in the trailing edge, which guarantees one clock cycle of hold time for transactions.

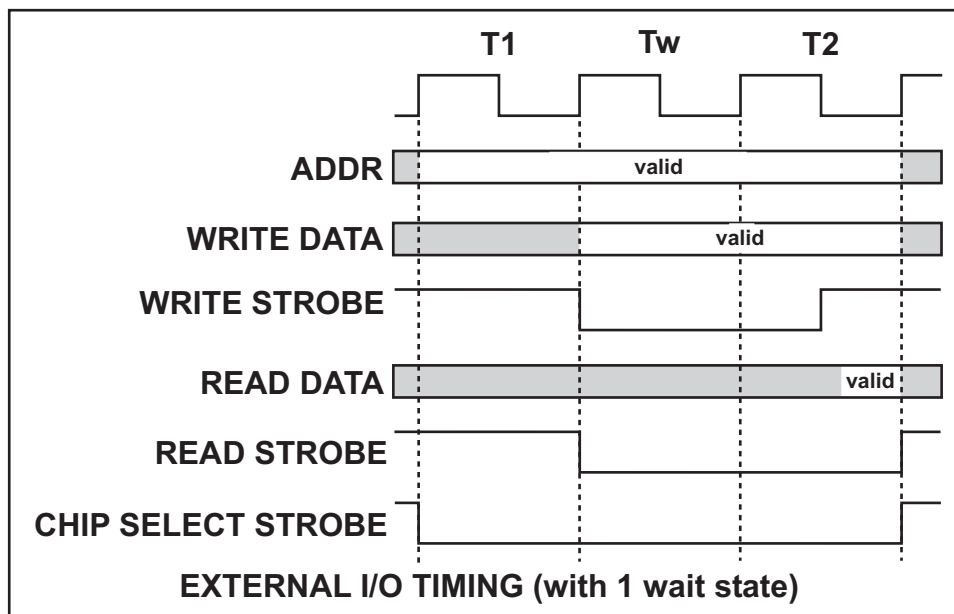

**Figure 27-1. External I/O Bus Cycles**

The strobes can be enabled to come out on Parallel Ports C, D, or E.

By default the I/O strobes are configured as read-only chip selects with 15 wait states and normal timing. These settings will affect the /IORD, /IOWR, and /BUFEN signals for external I/O writes even if no other strobe outputs are enabled in the parallel port registers.

### 27.1.3 I/O Handshake

An external I/O handshake input can be enabled on one of the Parallel Port E pins for any combination of the I/O banks. The external device holds this signal (active high or low) when it is busy and cannot accept a transaction. The Rabbit 5000 will then hold midway through the transaction until either the handshake signal goes inactive or a timeout occurs. The timeout can be defined anywhere from 32 to 2048 clocks. When the timeout occurs, the transaction ends and a status bit is set. This bit must be checked by the program attempting the write; no interrupt is generated.

The I/O handshake signal is sampled at the end of the first wait state ( $T_w$ ). When the handshake signal is disabled, the transition will start at the beginning of the  $T_w$  phase and continue to completion.

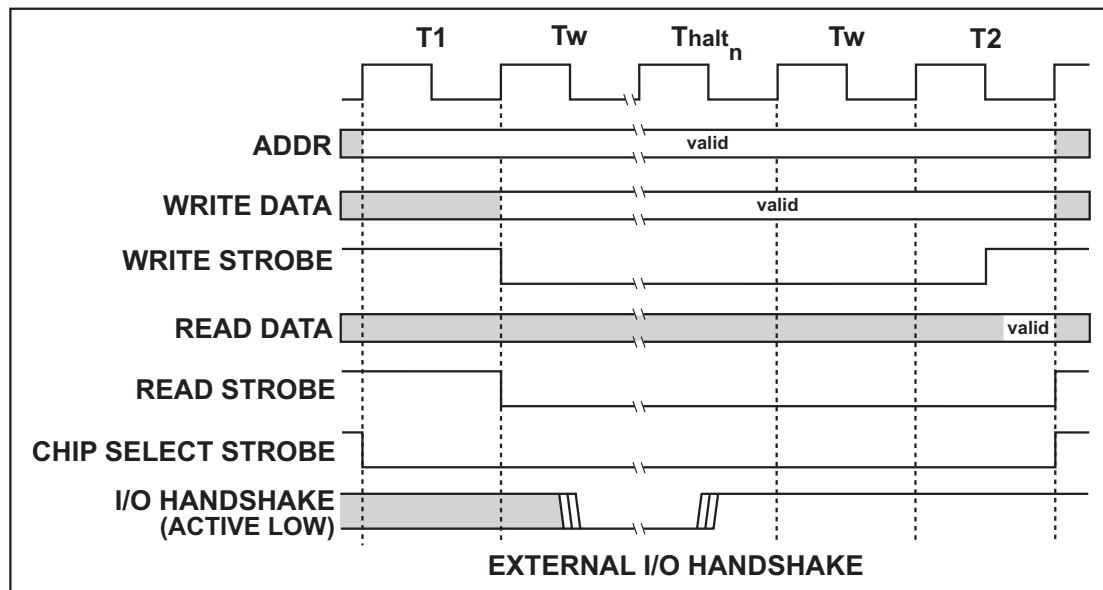
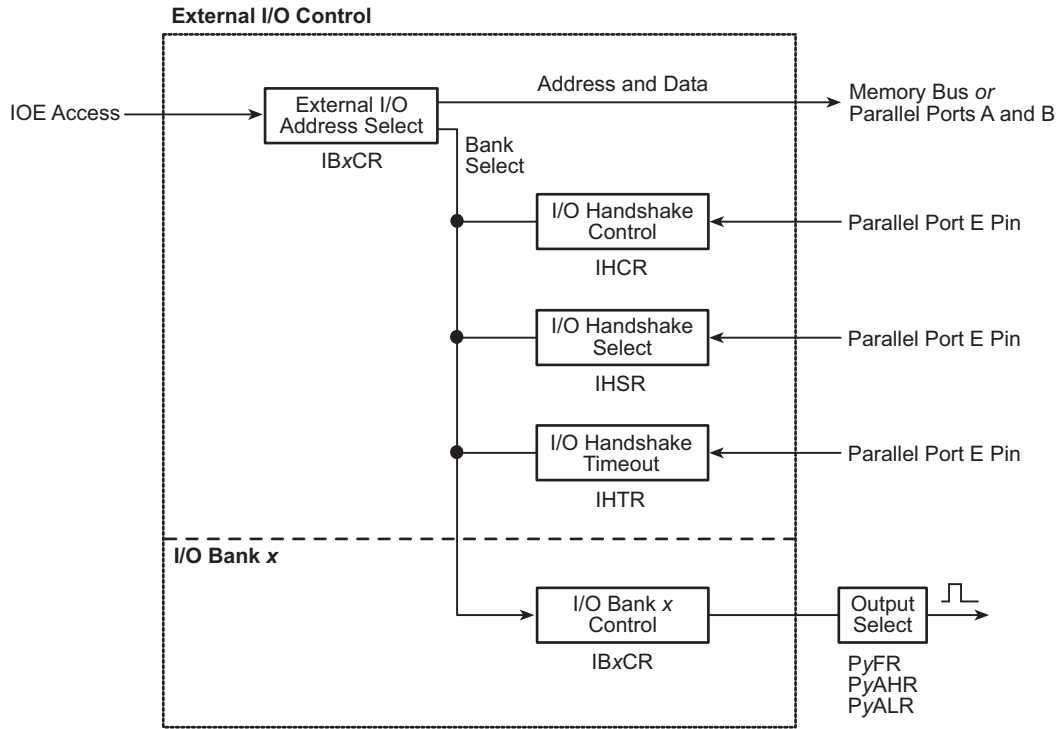

Figure 27-2. External I/O Handshake Timing Diagram

## 27.1.4 Block Diagram



## 27.1.5 Registers

Register Name	Mnemonic	I/O Address	R/W	Reset
I/O Handshake Control Register	IHCR	0x0028	R/W	00000000
I/O Handshake Select Register	IHSR	0x0029	R/W	00000000
I/O Handshake Timeout Register	IHTR	0x002A	R/W	00000000
I/O Bank 0 Control Register	IB0CR	0x0080	W	00000000
I/O Bank 1 Control Register	IB1CR	0x0081	W	00000000
I/O Bank 2 Control Register	IB2CR	0x0082	W	00000000
I/O Bank 3 Control Register	IB3CR	0x0083	W	00000000
I/O Bank 4 Control Register	IB4CR	0x0084	W	00000000
I/O Bank 5 Control Register	IB5CR	0x0085	W	00000000
I/O Bank 6 Control Register	IB6CR	0x0086	W	00000000
I/O Bank 7 Control Register	IB7CR	0x0087	W	00000000

## 27.2 Dependencies

### 27.2.1 I/O Pins

The external I/O bus uses PA0–PA7 for data, and either PB2–PB7 or PB0–PB7 for address lines, depending on the setting in SPCR. Address bits 6 and 7 can also be enabled on pins PD1, PD3, PD5, or PD7, which allows PB0 and PB1 to be used as clocked serial I/O instead of as external I/O.

The /IOWR, /IORD, and /BUFEN pins are dedicated strobes for external I/O accesses.

The I/O strobes can be directed out to pins on Parallel Ports C, D, or E; each bank can be directed to the appropriate pin (bank zero on PC0, PD0, or PE0; bank one on PC1, PD1, or PE1; etc.). The strobes will affect outputs on /IOWR, /IORD, and /BUFEN at all times.

The I/O handshake can be input on any one of the Parallel Port E pins (PE0–PE7).

### 27.2.2 Clocks

All external I/O accesses, strobes, and handshake timeouts are based on the processor clock.

### 27.2.3 Other Registers

Register	Function
SPCR	Enable the external I/O bus.
PCFR, PCALR, PCAHR PDFR, PDALR, PDAHR, PEFR, PEALR, PEAHR	Select Parallel Port C, D, or E pins as I/O strobe outputs. Select PD1, PD3, PD5, or PD7 as address bits 6-7.

### 27.2.4 Interrupts

There are no interrupts associated with external I/O.

## 27.3 Operation

### 27.3.1 External I/O Bus

The following steps must be taken before using external I/O bus:

1. Enable the external I/O bus by writing to SPCR. Select whether 6 or 8 address bits are desired.
2. If PB0 and PB1 are needed for clocked serial use and eight address bits are required, enable the alternate outputs of address bits 6 and 7 on Parallel Port D by writing to PDALR, PDAHR, and PDFR.
3. Set the I/O timing for a particular device by writing to the appropriate IBxCR register for the I/O bank desired.
4. If a strobe other than /IORD, /IOWR, or /BUFEN is required, enable the output of the IBxCR register by writing to the appropriate PxALR, PxAHR, and PxFR registers.

Once the external I/O bus is enabled, all memory read/write instructions prefixed with an IOE will go to either the memory bus or external I/O bus, depending on the setup in that bank's IBxCR register.

### 27.3.2 I/O Strobes

The following steps must be taken before using an I/O strobe:

1. Set the strobe type and timing for a particular device by writing to the appropriate IBxCR register for the I/O bank desired.
2. If signals other than /IORD, /IOWR, and /BUFEN are required, enable the output of the IBxCR register by writing to the appropriate PxALR, PxAHR, and PxFR registers.

On startup, the I/O strobes are set as chip selects with 15 wait states, read-only, active-low signaling, and will use the external I/O bus. These settings will be used for the dedicated I/O strobe pins /IORD, /IOWR, and /BUFEN whenever an external I/O write occurs even if not I/O strobe signals are being output on parallel port pins.

### 27.3.3 I/O Handshake

The following steps must be taken before using the I/O handshake:

1. Select the active level and desired port E bit to use as input by writing to IHCR.
2. Select which I/O banks the handshake is active for by writing to IHSR.
3. Select the handshake timeout value by writing to IHTR.

Once enabled, the handshake will be checked for every external I/O transaction in a bank that was enabled in IHSR. After these transactions, the program should check for a timeout by reading IHTR.

## 27.4 Register Descriptions

<b>I/O Handshake Control Register (IHCR) (Address = 0x0028)</b>		
<b>Bit(s)</b>	<b>Value</b>	<b>Description</b>
7:5		These bits are reserved and should be written with zeros.
4	0	I/O handshake is active low (I/O transaction held until signal goes high).
	1	I/O handshake is active high (I/O transaction held until signal goes low).
3		This bit is reserved and should be written with zero.
2:0	000	Use Parallel Port E bit 0 for I/O handshake.
	001	Use Parallel Port E bit 1 for I/O handshake.
	010	Use Parallel Port E bit 2 for I/O handshake.
	011	Use Parallel Port E bit 3 for I/O handshake.
	100	Use Parallel Port E bit 4 for I/O handshake.
	101	Use Parallel Port E bit 5 for I/O handshake.
	110	Use Parallel Port E bit 6 for I/O handshake.
	111	Use Parallel Port E bit 7 for I/O handshake.

<b>I/O Handshake Select Register (IHSR) (Address = 0x0029)</b>		
<b>Bit(s)</b>	<b>Value</b>	<b>Description</b>
7	0	Disable I/O handshake for I/O Bank 7.
	1	Enable I/O handshake for I/O Bank 7.
6	0	Disable I/O handshake for I/O Bank 6.
	1	Enable I/O handshake for I/O Bank 6.
5	0	Disable I/O handshake for I/O Bank 5.
	1	Enable I/O handshake for I/O Bank 5.
4	0	Disable I/O handshake for I/O Bank 4.
	1	Enable I/O handshake for I/O Bank 4.
3	0	Disable I/O handshake for I/O Bank 3.
	1	Enable I/O handshake for I/O Bank 3.
2	0	Disable I/O handshake for I/O Bank 2.
	1	Enable I/O handshake for I/O Bank 2.
1	0	Disable I/O handshake for I/O Bank 1.
	1	Enable I/O handshake for I/O Bank 1.
0	0	Disable I/O handshake for I/O Bank 0.
	1	Enable I/O handshake for I/O Bank 0.

<b>I/O Handshake Timeout Register (IHTR) (Address = 0x002A)</b>		
<b>Bit(s)</b>	<b>Value</b>	<b>Description</b>
7	0	No I/O handshake timeout has occurred since the last read of this register.
	1	An I/O handshake timeout has occurred since the last read of this register. This bit is cleared by a read of this register.
6		This bit is reserved and should be written with zero.
5:0		Time constant for the I/O handshake timeout counter. This time constant (times 32) selects the number of clocks that the I/O handshake input may delay completion of an I/O transaction before the I/O transaction will complete automatically.



<b>I/O Bank x Control Register</b>		
		<b>(IB0CR)</b> <b>(Address = 0x0080)</b>
		<b>(IB1CR)</b> <b>(Address = 0x0081)</b>
		<b>(IB2CR)</b> <b>(Address = 0x0082)</b>
		<b>(IB3CR)</b> <b>(Address = 0x0083)</b>
		<b>(IB4CR)</b> <b>(Address = 0x0084)</b>
		<b>(IB5CR)</b> <b>(Address = 0x0085)</b>
		<b>(IB6CR)</b> <b>(Address = 0x0086)</b>
		<b>(IB7CR)</b> <b>(Address = 0x0087)</b>
<b>Bit(s)</b>	<b>Value</b>	<b>Description</b>
7:6	00	Fifteen wait states for accesses in this bank.
	01	Seven wait states for accesses in this bank.
	10	Three wait states for accesses in this bank.
	11	One wait state for accesses in this bank.
5:4	00	The I signal is an I/O chip select.
	01	The I signal is an I/O read strobe.
	10	The I signal is an I/O write strobe.
	11	The I signal is an I/O data (read or write) strobe.
3	0	Writes are not allowed to this bank. Transactions are normal in every other way; only the write strobe is inhibited.
	1	Writes are allowed to this bank.
2	0	Active-low I signal.
	1	Inverted (active-high) I signal.
1	0	Normal I/O transaction timing.
	1	Shorten read strobe by one clock cycle and write strobe by one-half clock cycle. Transaction length remains the same. This guarantees one clock cycle hold time for both address and data for I/O transactions.
0	0	Use I/O bus if enabled.
	1	Always use memory data bus.

<b>Slave Port Control Register (SPCR) (Address = 0x0024)</b>		
<b>Bit(s)</b>	<b>Value</b>	<b>Description</b>
7	0	Program fetch as a function of the SMODE pins.
	1	Ignore the SMODE pins program fetch function.
6:5	Read	These bits report the state of the SMODE pins.
	Write	These bits are ignored and should be written with zero.
4:2	000	Disable the slave port. Parallel Port A is a byte-wide input port.
	001	Disable the slave port. Parallel Port A is a byte-wide output port.
	010	Enable the slave port, with /SCS from Parallel Port E bit 7.
	011	Enable the external I/O bus. Parallel Port A is used for the data bus and Parallel Port B[7:2] is used for the address bus.
	100	This bit combination is reserved and should not be used.
	101	This bit combination is reserved and should not be used.
	110	Enable the slave port, with /SCS from Parallel Port B bit 6.
	111	Enable the external I/O bus. Parallel Port A is used for the data bus and Parallel Port B[7:0] is used for the address bus.
1:0	00	Slave port interrupts are disabled.
	01	Slave port interrupts use Interrupt Priority 1.
	10	Slave port interrupts use Interrupt Priority 2.
	11	Slave port interrupts use Interrupt Priority 3.

<b>Parallel Port C Alternate Low Register (PCALR) (Address = 0x0052)</b>		
<b>Bit(s)</b>	<b>Value</b>	<b>Description</b>
7:6	00	Parallel Port C bit 3 alternate output 0 (TXC).
	01	Parallel Port C bit 3 alternate output 1 (I3).
	10	Parallel Port C bit 3 alternate output 2 (TIMER C3).
	11	Parallel Port C bit 3 alternate output 3 (SCLKD).
5:4	00	Parallel Port C bit 2 alternate output 0 (TXC).
	01	Parallel Port C bit 2 alternate output 1 (I2).
	10	Parallel Port C bit 2 alternate output 2 (TIMER C2).
	11	Parallel Port C bit 2 alternate output 3 (TXF).
3:2	00	Parallel Port C bit 1 alternate output 0 (TXD).
	01	Parallel Port C bit 1 alternate output 1 (I1).
	10	Parallel Port C bit 1 alternate output 2 (TIMER C1).
	11	Parallel Port C bit 1 alternate output 3 (RCLKF).
1:0	00	Parallel Port C bit 0 alternate output 0 (TXD).
	01	Parallel Port C bit 0 alternate output 1 (I0).
	10	Parallel Port C bit 0 alternate output 2 (TIMER C0).
	11	Parallel Port C bit 0 alternate output 3 (TCLKF).

<b>Parallel Port C Alternate High Register (PCAHR) (Address = 0x0053)</b>		
<b>Bit(s)</b>	<b>Value</b>	<b>Description</b>
7:6	00	Parallel Port C bit 7 alternate output 0 (TXA).
	01	Parallel Port C bit 7 alternate output 1 (I7).
	10	Parallel Port C bit 7 alternate output 2 (PWM3).
	11	Parallel Port C bit 7 alternate output 3 (SCLKC).
5:4	00	Parallel Port C bit 6 alternate output 0 (TXA).
	01	Parallel Port C bit 6 alternate output 1 (I6).
	10	Parallel Port C bit 6 alternate output 2 (PWM2).
	11	Parallel Port C bit 6 alternate output 3 (TXE).
3:2	00	Parallel Port C bit 5 alternate output 0 (TXB).
	01	Parallel Port C bit 5 alternate output 1 (I5).
	10	Parallel Port C bit 5 alternate output 2 (PWM1).
	11	Parallel Port C bit 5 alternate output 3 (RCLKE).
1:0	00	Parallel Port C bit 4 alternate output 0 (TXB).
	01	Parallel Port C bit 4 alternate output 1 (I4).
	10	Parallel Port C bit 4 alternate output 2 (PWM0).
	11	Parallel Port C bit 4 alternate output 3 (TCLKE).

<b>Parallel Port C Function Register (PCFR) (Address = 0x0055)</b>		
<b>Bit(s)</b>	<b>Value</b>	<b>Description</b>
7:0	0	The corresponding port bit functions normally.
	1	The corresponding port bit carries its alternate signal as an output. See Table 10-1.

<b>Parallel Port D Alternate Low Register (PDALR) (Address = 0x0062)</b>		
<b>Bit(s)</b>	<b>Value</b>	<b>Description</b>
7:6	00	Parallel Port D bit 3 alternate output 0 (IA7).
	01	Parallel Port D bit 3 alternate output 1 (I3).
	10	Parallel Port D bit 3 alternate output 2 (TIMER C3).
	11	Parallel Port D bit 3 alternate output 3 (SCLKD).
5:4	00	Parallel Port D bit 2 alternate output 0 (SCLKC).
	01	Parallel Port D bit 2 alternate output 1 (I2).
	10	Parallel Port D bit 2 alternate output 2 (TIMER C2).
	11	Parallel Port D bit 2 alternate output 3 (TXF).
3:2	00	Parallel Port D bit 1 alternate output 0 (IA6).
	01	Parallel Port D bit 1 alternate output 1 (I1).
	10	Parallel Port D bit 1 alternate output 2 (TIMER C1).
	11	Parallel Port D bit 1 alternate output 3 (RCLKF).
1:0	00	Parallel Port D bit 0 alternate output 0 (SCLKD).
	01	Parallel Port D bit 0 alternate output 1 (I0).
	10	Parallel Port D bit 0 alternate output 2 (TIMER C0).
	11	Parallel Port D bit 0 alternate output 3 (TCLKF).

<b>Parallel Port D Alternate High Register (PDAHR) (Address = 0x0063)</b>		
<b>Bit(s)</b>	<b>Value</b>	<b>Description</b>
7:6	00	Parallel Port D bit 7 alternate output 0 (IA7).
	01	Parallel Port D bit 7 alternate output 1 (I7).
	10	Parallel Port D bit 7 alternate output 2 (PWM3).
	11	Parallel Port D bit 7 alternate output 3 (SCLKC).
5:4	00	Parallel Port D bit 6 alternate output 0 (TXA).
	01	Parallel Port D bit 6 alternate output 1 (I6).
	10	Parallel Port D bit 6 alternate output 2 (PWM2).
	11	Parallel Port D bit 6 alternate output 3 (TXE).
3:2	00	Parallel Port D bit 5 alternate output 0 (IA6).
	01	Parallel Port D bit 5 alternate output 1 (I5).
	10	Parallel Port D bit 5 alternate output 2 (PWM1).
	11	Parallel Port D bit 5 alternate output 3 (RCLKE).
1:0	00	Parallel Port D bit 4 alternate output 0 (TXB).
	01	Parallel Port D bit 4 alternate output 1 (I4).
	10	Parallel Port D bit 4 alternate output 2 (PWM0).
	11	Parallel Port D bit 4 alternate output 3 (TCLKE).

<b>Parallel Port D Function Register (PDFR) (Address = 0x0065)</b>		
<b>Bit(s)</b>	<b>Value</b>	<b>Description</b>
7:0	0	The corresponding port bit functions normally.
	1	The corresponding port bit carries its alternate signal as an output. See Table 11-1.

<b>Parallel Port E Alternate Low Register (PEALR) (Address = 0x0072)</b>		
<b>Bit(s)</b>	<b>Value</b>	<b>Description</b>
7:6	00	Parallel Port E bit 3 alternate output 0 (I3).
	01	Parallel Port E bit 3 alternate output 1 (A23).
	10	Parallel Port E bit 3 alternate output 2 (TIMER C3).
	11	Parallel Port E bit 3 alternate output 3 (SCLKD).
5:4	00	Parallel Port E bit 2 alternate output 0 (I2).
	01	Parallel Port E bit 2 alternate output 1 (A22).
	10	Parallel Port E bit 2 alternate output 2 (TIMER C2).
	11	Parallel Port E bit 2 alternate output 3 (TXF).
3:2	00	Parallel Port E bit 1 alternate output 0 (I1).
	01	Parallel Port E bit 1 alternate output 1 (A21).
	10	Parallel Port E bit 1 alternate output 2 (TIMER C1).
	11	Parallel Port E bit 1 alternate output 3 (RCLKF).
1:0	00	Parallel Port E bit 0 alternate output 0 (I0).
	01	Parallel Port E bit 0 alternate output 1 (A20).
	10	Parallel Port E bit 0 alternate output 2 (TIMER C0).
	11	Parallel Port E bit 0 alternate output 3 (TCLKF).

<b>Parallel Port E Alternate High Register (PEAHR) (Address = 0x0073)</b>		
<b>Bit(s)</b>	<b>Value</b>	<b>Description</b>
7:6	00	Parallel Port E bit 7 alternate output 0 (I7).
	01	Parallel Port E bit 7 alternate output 1 (/ACT).
	10	Parallel Port E bit 7 alternate output 2 (PWM3).
	11	Parallel Port E bit 7 alternate output 3 (SCLKC).
5:4	00	Parallel Port E bit 6 alternate output 0 (I6).
	01	Parallel Port E bit 6 alternate output 1 (—).
	10	Parallel Port E bit 6 alternate output 2 (PWM2).
	11	Parallel Port E bit 6 alternate output 3 (TXE).
3:2	00	Parallel Port E bit 5 alternate output 0 (I5).
	01	Parallel Port E bit 5 alternate output 1 (/LINK).
	10	Parallel Port E bit 5 alternate output 2 (PWM1).
	11	Parallel Port E bit 5 alternate output 3 RCLKE).
1:0	00	Parallel Port E bit 4 alternate output 0 (I4).
	01	Parallel Port E bit 4 alternate output 1 (/A0).
	10	Parallel Port E bit 4 alternate output 2 (PWM0).
	11	Parallel Port E bit 4 alternate output 3 (TCLKE).

<b>Parallel Port E Function Register (PEFR) (Address = 0x0075)</b>		
<b>Bit(s)</b>	<b>Value</b>	<b>Description</b>
7:0	0	The corresponding port bit functions normally.
	1	The corresponding port bit carries its alternate signal as an output. See Table 12-1.



## 28. BREAKPOINTS

### 28.1 Overview

The Rabbit 5000 contains seven hardware breakpoints to support debugging. Each hardware breakpoint consists of a 24-bit address match register and a 24-bit mask register. A breakpoint can be generated on an address match for address execution, data read, data write, or any combination thereof. The mask register serves to mask off selected address bits from the address compare. A “one” in a particular bit position in the mask register inhibits the corresponding bit in the address match register from contributing to the address match condition.

When a match occurs, a Level 3 breakpoint interrupt is generated. Note that this means that breakpoints behave differently when the processor is running at Interrupt Priority 3 — the interrupt is generated but will not be handled until the processor drops to a lower priority.

In most cases, a code execution interrupt will be handled at the end of the instruction in which the match occurred. However, because of the time required to perform a 24-bit address match in the processor, a code execution breakpoint that is set on a single-byte, 2-clock instruction will not yet be enabled at the end of that instruction, and the interrupt will instead occur at the end of the next instruction.

Note that a breakpoint may be forced to be pending by setting the corresponding bit in BDCR. This feature allows a breakpoint request to be used as a virtual single-step request by always setting the appropriate bit in the interrupt handler. There is a particular sequence of instructions required to exit properly when the interrupt is left pending.

DMA transfers are treated as normal data reads and writes, although the DMA transfer will complete before the interrupt is taken.

Breakpoints can be enabled for the User Mode, the System Mode, or both.

Another breakpoint feature is the ability to disable the RST 28h instruction. The RST 28h vector was often used as a breakpoint feature by adding that instruction to code; by enabling a bit in BDCR, the RST 28h instruction will execute as a NOP instead, providing an easy way to disable that type of breakpoint.

### 28.1.1 Block Diagram

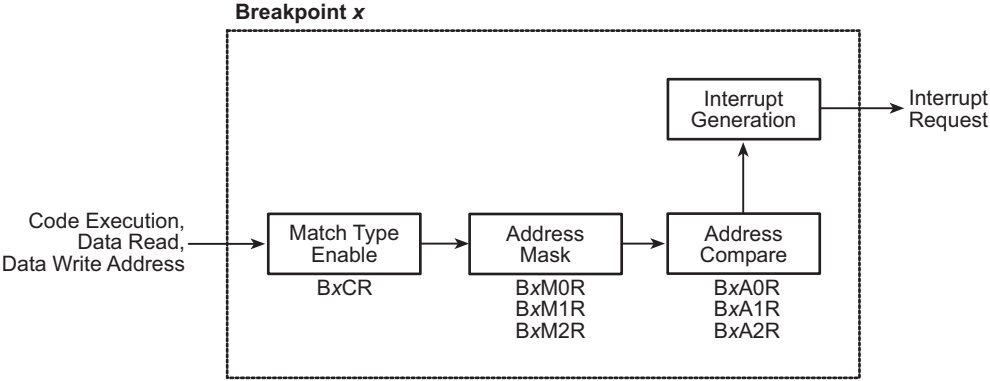

## 28.1.2 Registers

Register Name	Mnemonic	I/O Address	R/W	Reset
Breakpoint Debug/Control Register	BDCR	0x001C	R/W	00000000
Breakpoint 0 Control Register	B0CR	0x030B	R/W	00000000
Breakpoint 1 Control Register	B1CR	0x031B	R/W	00000000
Breakpoint 2 Control Register	B2CR	0x032B	R/W	00000000
Breakpoint 3 Control Register	B3CR	0x033B	R/W	00000000
Breakpoint 4 Control Register	B4CR	0x034B	R/W	00000000
Breakpoint 5 Control Register	B5CR	0x035B	R/W	00000000
Breakpoint 6 Control Register	B6CR	0x036B	R/W	00000000
Breakpoint 0 Address [0–2] Register	B0AxR	0x030C + x	R/W	00000000
Breakpoint 1 Address [0–2] Register	B1AxR	0x031C + x	R/W	00000000
Breakpoint 2 Address [0–2] Register	B2AxR	0x032C + x	R/W	00000000
Breakpoint 3 Address [0–2] Register	B3AxR	0x033C + x	R/W	00000000
Breakpoint 4 Address [0–2] Register	B4AxR	0x034C + x	R/W	00000000
Breakpoint 5 Address [0–2] Register	B5AxR	0x035C + x	R/W	00000000
Breakpoint 6 Address [0–2] Register	B6AxR	0x036C + x	R/W	00000000
Breakpoint 0 Mask [0–2] Register	B0MxR	0x0308 + x	R/W	00000000
Breakpoint 1 Mask [0–2] Register	B1MxR	0x0318 + x	R/W	00000000
Breakpoint 2 Mask [0–2] Register	B2MxR	0x0328 + x	R/W	00000000
Breakpoint 3 Mask [0–2] Register	B3MxR	0x0338 + x	R/W	00000000
Breakpoint 4 Mask [0–2] Register	B4MxR	0x0348 + x	R/W	00000000
Breakpoint 5 Mask [0–2] Register	B5MxR	0x0358 + x	R/W	00000000
Breakpoint 6 Mask [0–2] Register	B6MxR	0x0368 + x	R/W	00000000

## 28.2 Dependencies

### 28.2.1 I/O Pins

There are no I/O pins associated with breakpoints.

### 28.2.2 Clocks

There are no clocks associated with breakpoints.

### 28.2.3 Other Registers

There are no other registers associated with breakpoints.

### 28.2.4 Interrupts

When an enabled address match occurs for a given breakpoint, a breakpoint interrupt occurs. The breakpoint that caused the interrupt must be determined by reading BDCR, which also clears the interrupt. Any of the breakpoint interrupts can be enabled by writing to BDCR.

The breakpoint interrupt vector is in the EIR at offset 0x040. It is always set to Interrupt Priority 3, and is the highest priority interrupt; if two Interrupt Priority 3 vectors are pending, the breakpoint interrupt will always be handled first.

## 28.3 Operation

The following steps must be taken to enable breakpoints:

1. Write the vector to the interrupt service routine to the external interrupt table.
2. Write the desired breakpoint addresses to the appropriate breakpoint address registers (BxAyR, where x is the breakpoint and y is the byte of the address, 0-2).
3. Write an address mask for the given breakpoints (BxMyR).
4. Select the breakpoint address match type (execute, data read, data write) by writing to the appropriate BxCR.
5. Enable the desired breakpoints by writing to BDCR.

### 28.3.1 Handling Interrupts

The following actions occur within the interrupt service routine.

- Which breakpoints are pending should be determined by reading BDCR. This also clears the pending breakpoints.
- The desired breakpoint action should be taken.
- If single-step functionality is desired, the breakpoint interrupt should be re-enabled by writing the appropriate bit to BDCR. If this is done, the interrupt handler needs to be exited in a particular manner (see below).

### 28.3.2 Example ISR

A sample interrupt handler is shown below.

```
breakpoint_isr::
    push af
    ioi ld a, (BDCR) ; determine which interrupts are pending and
                    ; clear the interrupt request

    ; handle all breakpoints here

    ; reenale any breakpoints by writing to BDCR

    pop af
    ipres          ; you must exit the handler with these two
    ret           ; instructions if you reenaled breakpoints
```

## 28.4 Register Descriptions

<b>Breakpoint/Debug Control Register (BDCR) (Address = 0x001C)</b>		
<b>Bit(s)</b>	<b>Value</b>	<b>Description</b>
7	0	Normal RST 0x28 operation.
	1	RST 0x28h is NOP.
6:0	0	The corresponding Breakpoint request is not pending.
	1	The corresponding Breakpoint request is pending. Reading this register automatically clears all pending breakpoint requests.
6:0	0	No effect on the corresponding Breakpoint request.
	1	Make the corresponding Breakpoint request pending.

<b>Breakpoint x Control Register (B0CR) (Address = 0x030B)</b>		
<b>(B1CR) (Address = 0x031B)</b>		
<b>(B2CR) (Address = 0x032B)</b>		
<b>(B3CR) (Address = 0x033B)</b>		
<b>(B4CR) (Address = 0x034B)</b>		
<b>(B5CR) (Address = 0x036B)</b>		
<b>(B6CR) (Address = 0x037B)</b>		
<b>Bit(s)</b>	<b>Value</b>	<b>Description</b>
7:6	00	No Breakpoint x on execute address match.
	01	Breakpoint x on User Mode execute address match.
	10	Breakpoint x on System Mode execute address match.
	11	Breakpoint x on System or User Mode execute address match.
5:4	00	No breakpoint x on data read address match.
	01	Breakpoint x on User Mode data read address match.
	10	Breakpoint x on System Mode data read address match.
	11	Breakpoint x on System or User Mode data read address match.
3:2	00	No breakpoint x on write address match.
	01	Breakpoint x on User Mode write address match.
	10	Breakpoint x on System Mode write address match.
	11	Breakpoint x on System or User Mode write address match.
1:0		These bits are reserved and should be written with zeros.

<b>Breakpoint x Address 0 Register</b>		
	(B0A0R)	(Address = 0x030C)
	(B1A0R)	(Address = 0x031C)
	(B2A0R)	(Address = 0x032C)
	(B3A0R)	(Address = 0x033C)
	(B4A0R)	(Address = 0x034C)
	(B5A0R)	(Address = 0x036C)
	(B6A0R)	(Address = 0x037C)
Bit(s)	Value	Description
7:0		Breakpoint x Address [7:0].

<b>Breakpoint x Address 1 Register</b>		
	(B0A1R)	(Address = 0x030D)
	(B1A1R)	(Address = 0x031D)
	(B2A1R)	(Address = 0x032D)
	(B3A1R)	(Address = 0x033D)
	(B4A1R)	(Address = 0x034D)
	(B5A1R)	(Address = 0x036D)
	(B6A1R)	(Address = 0x037D)
Bit(s)	Value	Description
7:0		Breakpoint x Address [15:8].

<b>Breakpoint x Address 2 Register</b>		
	(B0A2R)	(Address = 0x030E)
	(B1A2R)	(Address = 0x031E)
	(B2A2R)	(Address = 0x032E)
	(B3A2R)	(Address = 0x033E)
	(B4A2R)	(Address = 0x034E)
	(B5A2R)	(Address = 0x036E)
	(B6A2R)	(Address = 0x037E)
Bit(s)	Value	Description
7:0		Breakpoint x Address [23:16].

<b>Breakpoint x Mask 0 Register</b>		
	<b>(B0M0R)</b>	<b>(Address = 0x0308)</b>
	<b>(B1M0R)</b>	<b>(Address = 0x0318)</b>
	<b>(B2M0R)</b>	<b>(Address = 0x0328)</b>
	<b>(B3M0R)</b>	<b>(Address = 0x0338)</b>
	<b>(B4M0R)</b>	<b>(Address = 0x0348)</b>
	<b>(B5M0R)</b>	<b>(Address = 0x0368)</b>
	<b>(B6M0R)</b>	<b>(Address = 0x0378)</b>
<b>Bit(s)</b>	<b>Value</b>	<b>Description</b>
7:0		Breakpoint x Mask [7:0]. (A one in a bit position inhibits the address compare for that bit position.)

<b>Breakpoint x Mask 1 Register</b>		
	<b>(B0M1R)</b>	<b>(Address = 0x0309)</b>
	<b>(B1M1R)</b>	<b>(Address = 0x0319)</b>
	<b>(B2M1R)</b>	<b>(Address = 0x0329)</b>
	<b>(B3M1R)</b>	<b>(Address = 0x0339)</b>
	<b>(B4M1R)</b>	<b>(Address = 0x0349)</b>
	<b>(B5M1R)</b>	<b>(Address = 0x0369)</b>
	<b>(B6M1R)</b>	<b>(Address = 0x0379)</b>
<b>Bit(s)</b>	<b>Value</b>	<b>Description</b>
7:0		Breakpoint x Mask [15:8]. (A one in a bit position inhibits the address compare for that bit position.)

<b>Breakpoint x Mask 2 Register</b>		
	<b>(B0M2R)</b>	<b>(Address = 0x030A)</b>
	<b>(B1M2R)</b>	<b>(Address = 0x031A)</b>
	<b>(B2M2R)</b>	<b>(Address = 0x032A)</b>
	<b>(B3M2R)</b>	<b>(Address = 0x033A)</b>
	<b>(B4M2R)</b>	<b>(Address = 0x034A)</b>
	<b>(B5M2R)</b>	<b>(Address = 0x036A)</b>
	<b>(B6M2R)</b>	<b>(Address = 0x037A)</b>
<b>Bit(s)</b>	<b>Value</b>	<b>Description</b>
7:0		Breakpoint x Mask [23:16]. (A one in a bit position inhibits the address compare for that bit position.)



## 29. LOW-POWER OPERATION

### 29.1 Overview

The Rabbit 5000 contains several power-saving features. Since the power consumed by the processor is proportional to the clock speed, the Rabbit 5000 provides 12 clock modes that can go as low as 2 kHz. To further reduce power consumption in those ultra-sleepy modes, various shortened chip select strobes are available to reduce current draw by the attached memory devices.

Figure 29-1 shows a typical current draw as a function of the main clock frequency. The values shown do not include any current consumed by external oscillators or memory. It is assumed that approximately 30 pF is connected to each address line.

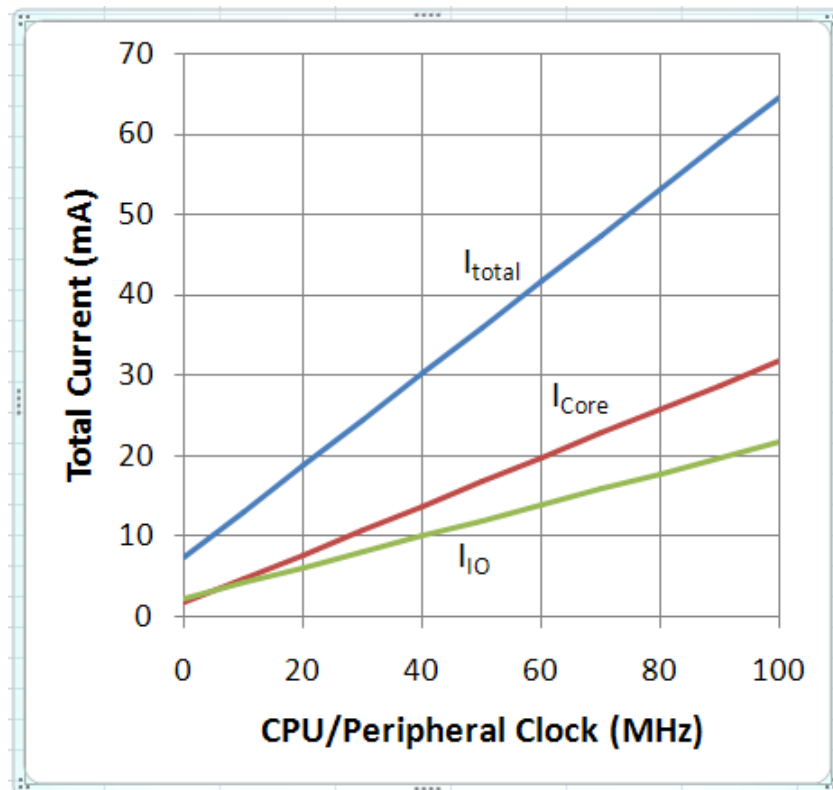

**Figure 29-1. Typical Current Draw as a Function of the Main Clock Frequency**

The typical current draw in the ultra-sleepy modes is 2 mA for  $I_{CORE}$  and 5 mA for  $I_{IO}$ , depending on the pin activity.

### 29.1.1 Registers

Register Name	Mnemonic	I/O Address	R/W	Reset
Global Control/Status Register	GCSR	0x0000	R/W	11000000
Global Power Save Control Register	GPSCR	0x000D	R/W	00000000
Global Clock Double Register	GCDR	0x000F	R/W	00000000

## 29.2 Operation

### 29.2.1 Unused Pins

Input (or bidirectional) pins that are unused in a design can pick up noise that may cause the transistors in the input buffer to switch states quickly, causing unnecessary current draw. To avoid this, all unused pins should be connected to a weak pullup or pulldown resistor (approximately 100 kΩ) and left as inputs. This provides protection from noise when the pin is an input, but also limits the current draw if the pin gets inadvertently enabled as an output.

### 29.2.2 Clock Rates

The processor and peripheral clocks in the Rabbit 5000 can be run in six different modes using the main oscillator: full speed; divided by 2, 4, 6, or 8; and the processor clock divided by 8 with the peripheral clock at full speed. If the clock doubler is enabled, the options also include twice the main oscillator frequency and the main oscillator divided by 3.

In addition, the 32 kHz clock can be used for the processor and peripheral clocks; the 32 kHz clock can also be divided by 2, 4, 8, or 16, which provides dramatically lower power consumption.

Table 29-1 lists the options for the clock modes and the processor clock frequency.

**Table 29-1. Clock Modes**

Main Oscillator GCSR Setting	Clock Doubler	32 kHz Divider	Processor Clock Frequency
Full	On	N/A	2 × Main Oscillator
Full	Off		Main Oscillator
Divided by 2	On		Main Oscillator / 2
Divided by 2	Off		Main Oscillator / 3
Divided by 4	On		Main Oscillator / 4
Divided by 6	On		Main Oscillator / 6
Divided by 4	Off		Main Oscillator / 8
Divided by 8	On		
Divided by 6	Off		
Divided by 8	Off		
Off (32 kHz divider used)	N/A	Disabled	32.768 kHz
		/ 2	16.384 kHz
		/ 4	8.192 kHz
		/ 8	4.096 kHz
		/ 16	2.048 kHz

Depending on the application, the processor can continue executing code normally when the main oscillator is divided down to a lower value. However, when the processor clock is running off of the 32 kHz clock, it is recommended that the Rabbit 5000 be performing a tight polling loop, waiting for a wake-up event.

### 29.2.3 Short Chip Selects

When running at a reduced clock speed, it is likely that the chip selects for external devices will not need to be active for an entire clock cycle. By reducing the width of the chip select, the power consumption of the memory chip can be reduced without having any affect on the processor itself.

For reduced processor speeds based on the main oscillator, a short chip select can be enabled in GPSCR (this feature is not available when the processor is running at full speed). This feature can be enabled separately for both reads and writes. When enabled, the chip select signals will be the width of two undivided clocks and located at the end of the transaction. The read data in the figures below is sampled by the rising edge of CLKI that terminated the T2 cycle. Wait states are inserted between T1 and T2 so they do not affect the width of the strobe.

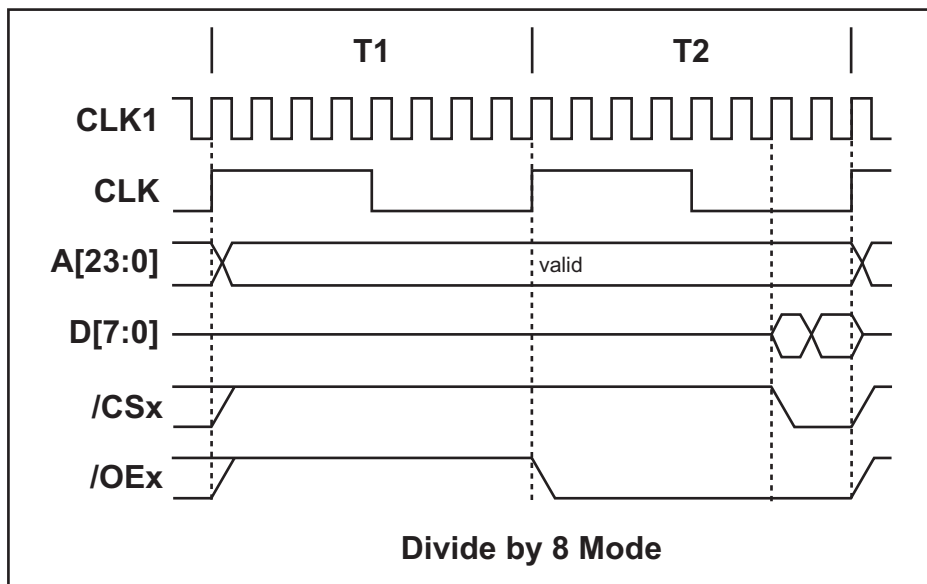

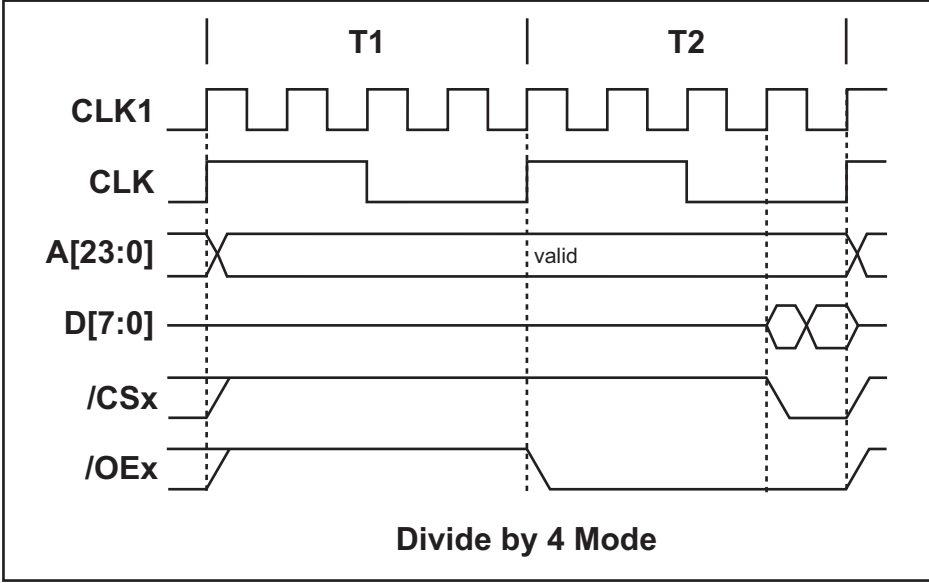
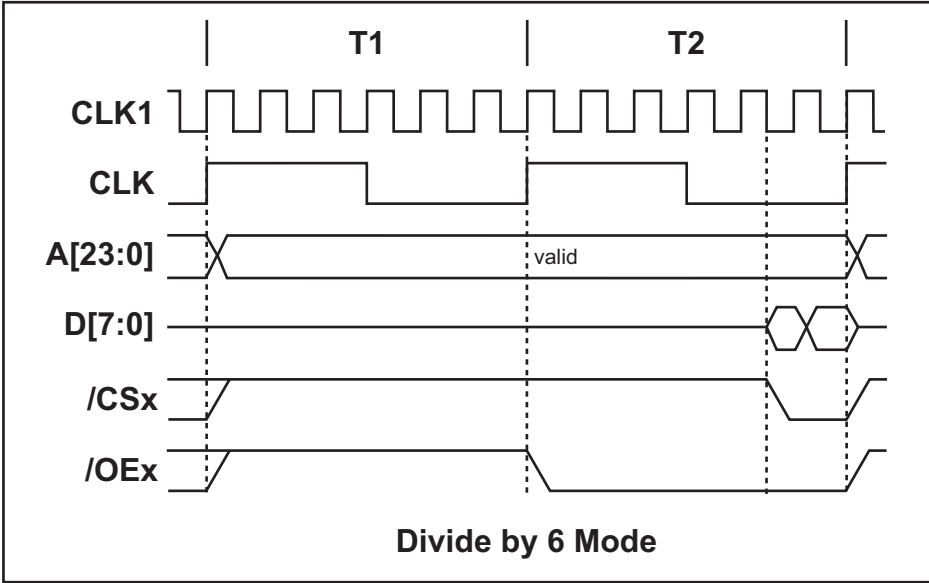

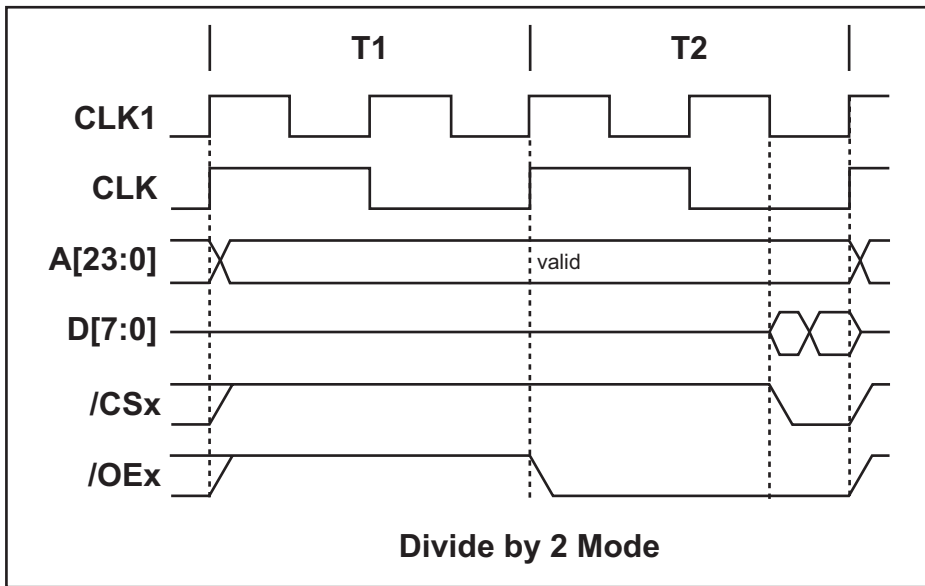

When the processor is running off the 32 kHz clock, the short chip select option will produce chip select signal that is the width of a single 32 kHz clock (30.5 microseconds); otherwise the timing is identical to the short chip select options based off the main oscillator. Read strobe figures are shown below.

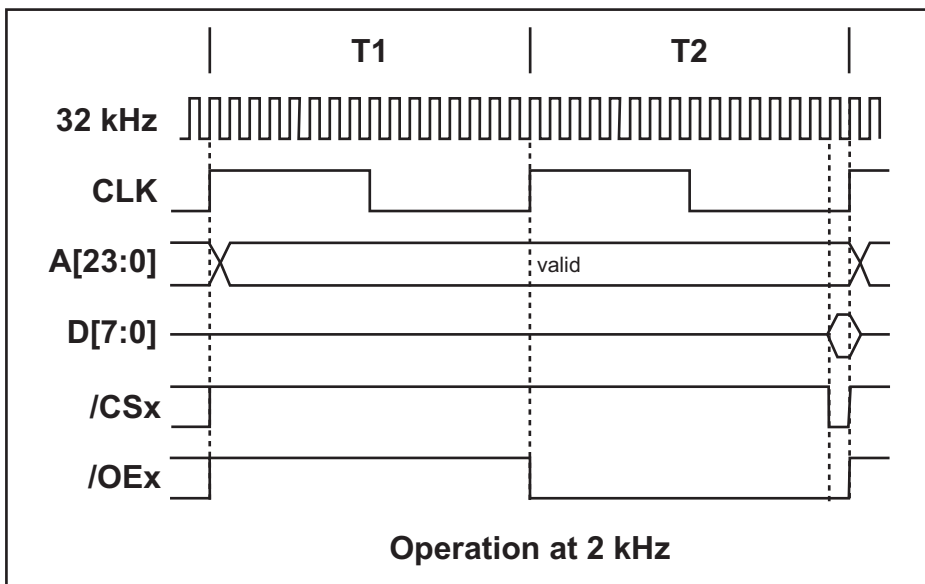

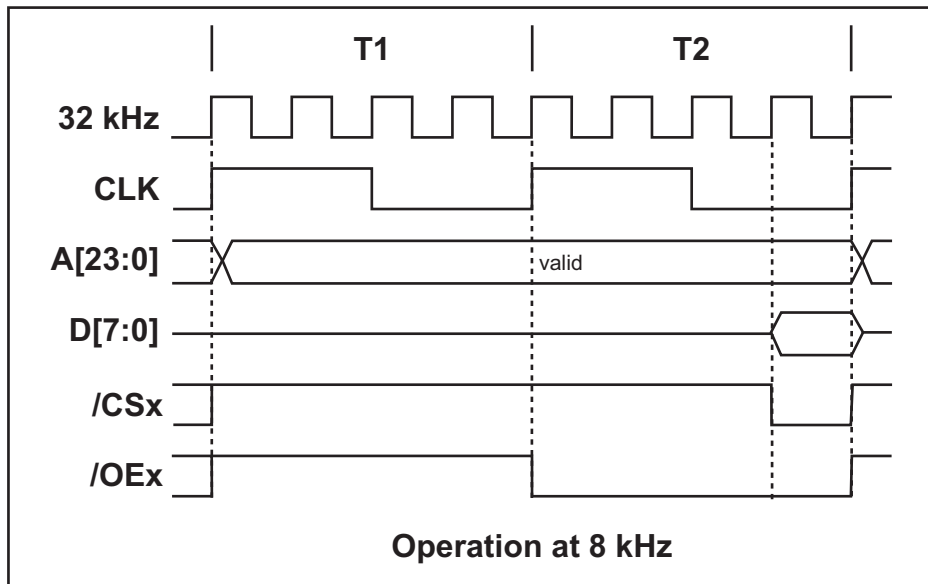
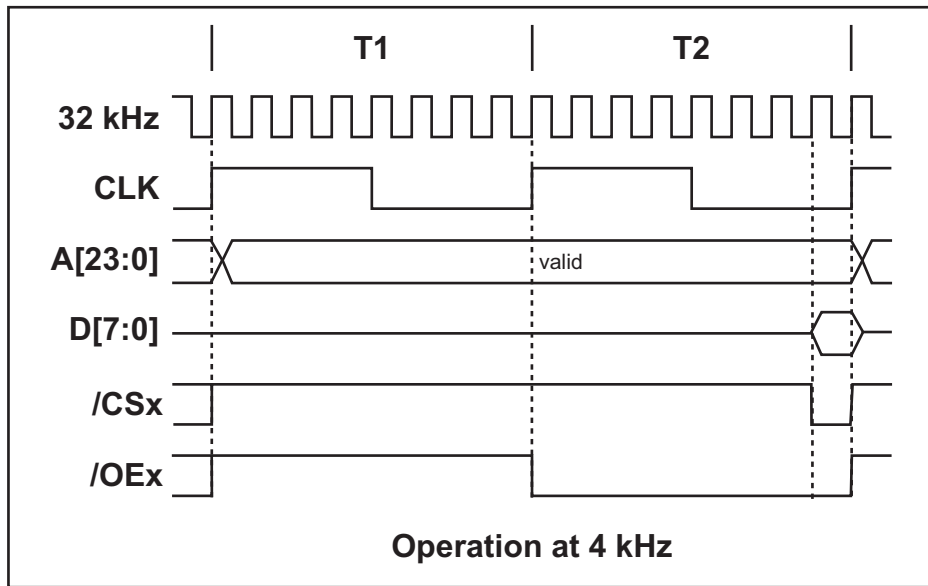

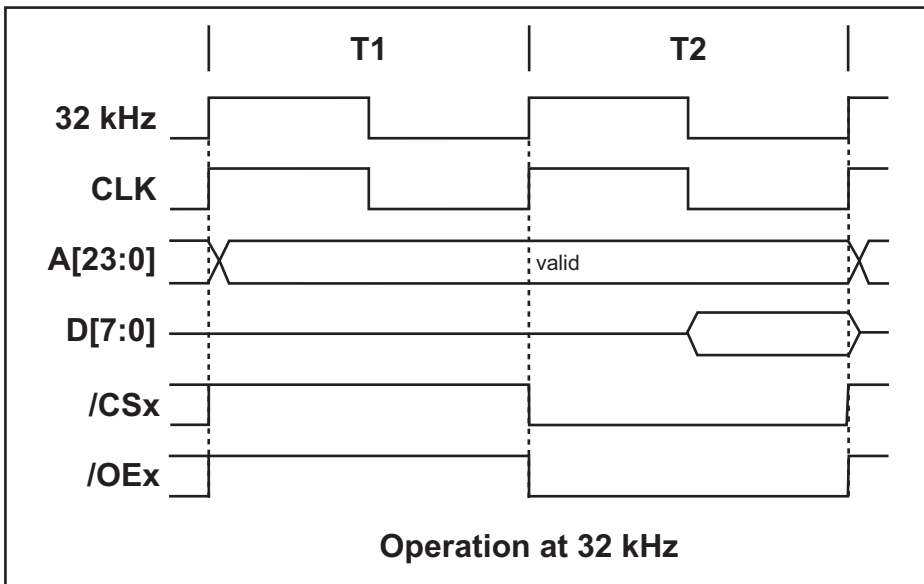
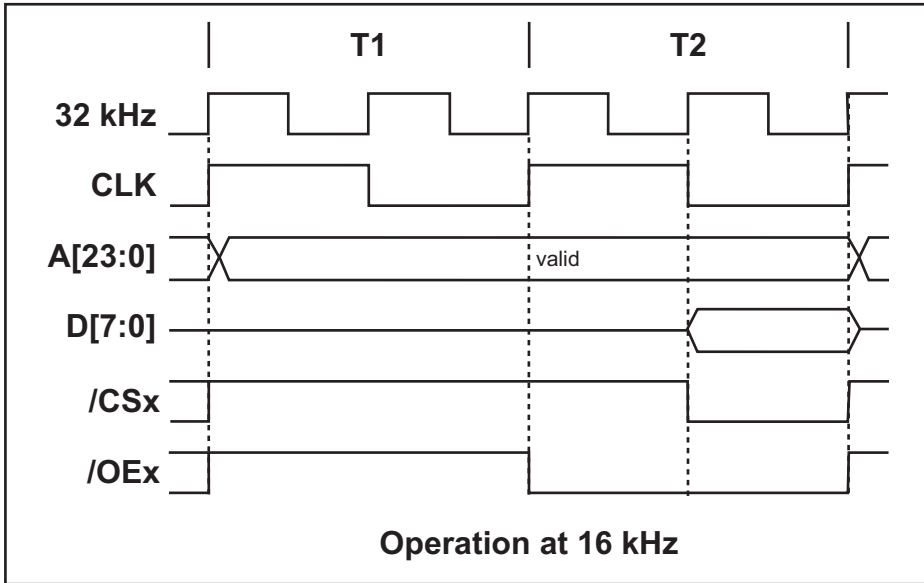



### 29.2.4 Self-Timed Chip Selects

Self-timed chip selects can be enabled via GPSCR to reduce power consumption even more when running off the 32 kHz oscillator. When self-timed chip selects are enabled, the chip select is only active for a short (selectable) period of time ranging from 110 to 290 ns; this can be enable for both reads and writes, or reads only. A sample read and write timing diagram is shown below.

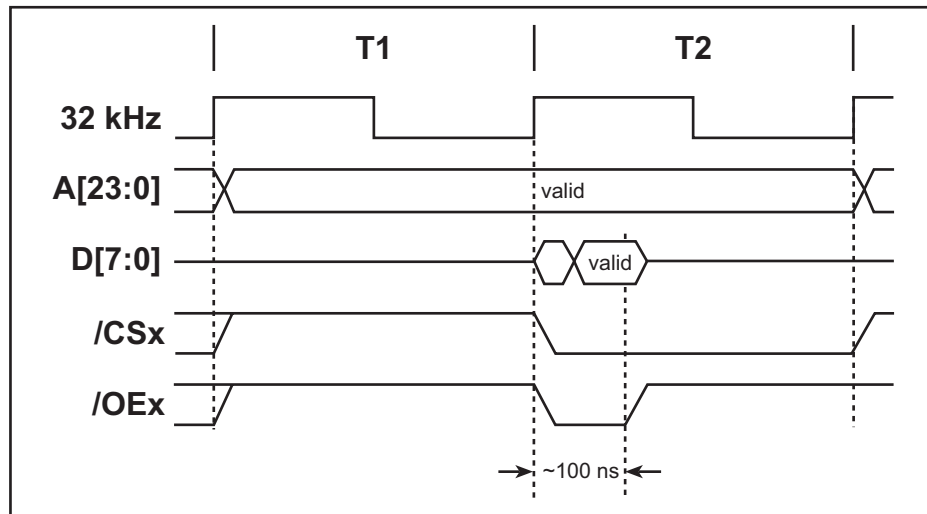

## 29.3 Register Descriptions

Global Control/Status Register (GCSR) (Address = 0x0000)		
Bit(s)	Value	Description
7:6 (rd-only)	00	No reset or watchdog timer timeout since the last read.
	01	The watchdog timer timed out. These bits are cleared by a read of this register.
	10	This bit combination is not possible.
	11	Reset occurred. These bits are cleared by a read of this register.
5	0	No effect on the periodic interrupt. This bit will always be read as zero.
	1	Force a periodic interrupt to be pending.
4:2	000	Processor clock from the fast clock, divided by 8. Peripheral clock from the fast clock, divided by 8.
	001	Processor clock from the fast clock, divided by 8. Peripheral clock from the fast clock.
	010	Processor clock from the fast clock. Peripheral clock from the fast clock.
	011	Processor clock from the fast clock, divided by 2. Peripheral clock from the fast clock, divided by 2.
	100	Processor clock from the 32 kHz clock, optionally divided via GPSCR. Peripheral clock from the 32 kHz clock, optionally divided via GPSCR.
	101	Processor clock from the 32 kHz clock, optionally divided via GPSCR. Peripheral clock from the 32 kHz clock, optionally divided via GPSCR. The fast clock is disabled.
	110	Processor clock from the fast clock, divided by 4. Peripheral clock from the fast clock, divided by 4.
	111	Processor clock from the fast clock, divided by 6. Peripheral clock from the fast clock, divided by 6.
1:0	00	Periodic interrupts are disabled.
	01	Periodic interrupts use Interrupt Priority 1.
	10	Periodic interrupts use Interrupt Priority 2.
	11	Periodic interrupts use Interrupt Priority 3.

<b>Global Power Save Control Register (GPSCR) (Address = 0x000D)</b>		
<b>Bit(s)</b>	<b>Value</b>	<b>Description</b>
7:5	000	Self-timed chip selects are disabled.
	001	230 ns self-timed chip selects for read and write.
	010	170 ns self-timed chip selects for read and write.
	011	110 ns self-timed chip selects for read and write.
	100	290 ns self-timed chip selects for read only.
	101	230 ns self-timed chip selects for read only.
	110	170 ns self-timed chip selects for read only.
	111	110 ns self-timed chip selects for read only.
4	0	Normal chip select timing for read cycles.
	1	Short chip select timing for read cycles (not available in full speed).
3	0	Normal chip select timing for write cycles
	1	Short chip select timing for write cycles (not available in full speed).
2:0	000	The 32 kHz clock divider is disabled.
	001	This bit combination is reserved and should not be used.
	010	This bit combination is reserved and should not be used.
	011	This bit combination is reserved and should not be used.
	100	32 kHz clock divided by 2 (16.384 kHz).
	101	32 kHz clock divided by 4 (8.192 kHz).
	110	32 kHz clock divided by 8 (4.096 kHz).
	111	32 kHz clock divided by 16 (2.048 kHz).

<b>Global Clock Double Register (GCDR) (Address = 0x000F)</b>		
<b>Bit(s)</b>	<b>Value</b>	<b>Description</b>
7:5		These bits are reserved and should be written with zeros.
4:0	00000	The clock doubler circuit is disabled.
	00001	6 ns nominal low time.
	00010	7 ns nominal low time.
	00011	8 ns nominal low time.
	00100	9 ns nominal low time.
	00101	10 ns nominal low time.
	00110	11 ns nominal low time.
	00111	12 ns nominal low time.
	01000	13 ns nominal low time.
	01001	14 ns nominal low time.
	01010	15 ns nominal low time.
	01011	16 ns nominal low time.
	01100	17 ns nominal low time.
	01101	18 ns nominal low time.
	01110	19 ns nominal low time.
	01111	20 ns nominal low time.
	10001	3 ns nominal low time.
	10010	4 ns nominal low time.
10011	5 ns nominal low time.	
other		Any bit combination not listed is reserved and must not be used.

## 30. SYSTEM/USER MODE

### 30.1 Overview

The Rabbit 5000 provides support for two tiers of control in the processor: *System Mode*, which provides full access to all processor resources; and *User Mode*, a more restricted mode. Table 30-1 describes the essential differences between the System Mode and the User Mode. The System Mode is essentially the same as the normal operation when the System/User Mode is disabled.

**Table 30-1. Differences Between System Mode and User Mode**

System Mode	User Mode
All peripherals accessible.	No peripherals accessible by default.
All processor control registers available.	No processor control registers available.
All interrupt priorities available.	Interrupt Priority 3 not allowed.
IDET instruction has no effect.	IDET instruction causes Priority 3 “System mode violation” interrupt.
No write protection when 0x00 is written to WPCR (write protection in User mode only)	Write to protected segment causes Priority 3 “write protection violation” interrupt.
Easy to enter user mode (SETUSR instruction).	Difficult to enter system mode (requires interrupt, SYSCALL, or RST instruction).

The main intent of the System/User Mode is to protect critical code (for example, code that performs remote firmware updates), data, and the current processor state (memory setup, peripheral control, etc.) from inadvertent changes by the user’s standard code. By removing access to the processor’s I/O registers and preventing memory writes to critical regions, the user’s code can run without the danger of locking up the processor to the point where it cannot be restarted remotely and/or new code uploaded.

### 30.1.1 Registers

Register Name	Mnemonic	I/O Address	R/W	Reset
Enable Dual-Mode Register	EDMR	0x0420	W	00000000
Real-Time Clock User Enable Register	RTUER	0x0300	W	00000000
Slave Port User Enable Register	SPUER	0x0320	W	00000000
Parallel Port A User Enable Register	PAUER	0x0330	W	00000000
Parallel Port B User Enable Register	PBUER	0x0340	W	00000000
Parallel Port C User Enable Register	PCUER	0x0350	W	00000000
Parallel Port D User Enable Register	PDUER	0x0360	W	00000000
Parallel Port E User Enable Register	PEUER	0x0370	W	00000000
Input Capture User Enable Register	ICUER	0x0358	W	00000000
I/O Bank User Enable Register	IBUER	0x0380	W	00000000
PWM User Enable Register	PWUER	0x0388	W	00000000
Quad Decode User Enable Register	QDUER	0x0390	W	00000000
External Interrupt User Enable Register	IUER	0x0398	W	00000000
Timer A User Enable Register	TAUER	0x03A0	W	00000000
Analog User Enable Register	AUER	0x03A8	W	00000000
Timer B User Enable Register	TBUER	0x03B0	W	00000000
Timer C User Enable Register	TCUER	0x3F8	W	00000000
Serial Port A User Enable Register	SAUER	0x03C0	W	00000000
Serial Port B User Enable Register	SBUER	0x3D0	W	00000000
Serial Port C User Enable Register	SCUER	0x3E0	W	00000000
Serial Port D User Enable Register	SDUER	0x3F0	W	00000000
Serial Port E User Enable Register	SEUER	0x03C8	W	00000000
Serial Port F User Enable Register	SFUER	0x3D8	W	00000000
Enable Dual-Mode Register	EDMR	0x0420	R/W	00000000

## 30.2 Dependencies

### 30.2.1 I/O Pins

There are no pin dependencies for the System/User Mode.

### 30.2.2 Clocks

There are no clock dependencies for the System/User Mode.

### 30.2.3 Other Registers

Any writes to the internal I/O registers listed in Table 30-2 are ignored when the System/User Mode is enabled and the processor is in the User Mode.

**Table 30-2. I/O Addresses Inaccessible in User Mode**

Register Name	Mnemonic	I/O Address
Global Control/Status Register	GCSR	0x0000
Watchdog Timer Control Register	WDTCR	0x0008
Watchdog Timer Test Register	WDTTR	0x0009
Global Clock Modulator 0 Register	GCM0R	0x000A
Global Clock Modulator 1 Register	GCM1R	0x000B
Secondary Watchdog Timer Register	SWDTR	0x000C
Global Power Save Control Register	GPSCR	0x000D
Global Output Control Register	GOCR	0x000E
Global Clock Double Register	GCDR	0x000F
MMU Instruction/Data Register	MMIDR	0x0010
Stack Segment Register	STACKSEG	0x0011
Data Segment Register	DATASEG	0x0012
Segment Size Register	SEGSIZE	0x0013
Memory Bank 0 Control Register	MB0CR	0x0014
Memory Bank 1 Control Register	MB1CR	0x0015
Memory Bank 2 Control Register	MB2CR	0x0016
Memory Bank 3 Control Register	MB3CR	0x0017
MMU Expanded Code Register	MECR	0x0018
Memory Timing Control Register	MTCR	0x0019
Stack Segment Low Register	STACKSEGL	0x001A
Stack Segment High Register	STACKSEGH	0x001B
Breakpoint/Debug Control Register	BDCR	0x001C
Memory Alternate Control Register	MACR	0x001D
Data Segment Low Register	DATSEGL	0x001E

**Table 30-2. I/O Addresses Inaccessible in User Mode (continued)**

Register Name	Mnemonic	I/O Address
Data Segment High Register	DATSEGH	0x001F
DMA registers		0x0100 – 0x01FF
Network Port B registers		0x0200 – 0x02FF
User Enable and Breakpoint registers		0x0300 – 0x03FF
Memory Protection registers		0x0400 – 0x04FF
Network Port C registers		0x0A00 – 0x0AFF

### 30.2.4 Interrupts

The System Mode Violation interrupt occurs whenever the IDET instruction is executed while the System/User mode is enabled and the processor is in the User Mode. Its purpose is to trap when system code is being executed while the processor is in the User Mode.

The System Mode Violation interrupt vector is in the IIR at offset 0x180. It always occurs at Priority 3.

Note that Priority 3 is not available while the System/User Mode is enabled and the processor is in the User Mode. If the processor is placed into Priority 3 either by an instruction or an interrupt, it will respond as if it was set to Priority 2.

When the System/User Mode is enabled, it is critical to handle the SU stack in interrupts as well as the IP stack; always perform a **SURES** before the **IPRES** at the end of the interrupt.



### 30.3 Operation

The System/User Mode is designed to work with the memory and stack protection features of the Rabbit 5000 processor to provide a seamless framework for protection of critical code. However, there are many levels at which the System/User Mode can be used — some examples are described here.

#### 30.3.1 Memory Protection Only

At the beginning of the user program, all necessary peripherals are enabled, all peripheral interrupts to be used are set up for the User Mode, critical memory regions are protected, stack limits are set, and the various system/memory/stack violation interrupts are enabled. The processor then enters the User Mode and remains in the User Mode for all operations (interrupts can be handled however the user desires). Obviously the critical interrupts can be handled in the System Mode, but at that point the device is typically reset and the error is logged. Figure 30-1 shows an overview of this level of operation.

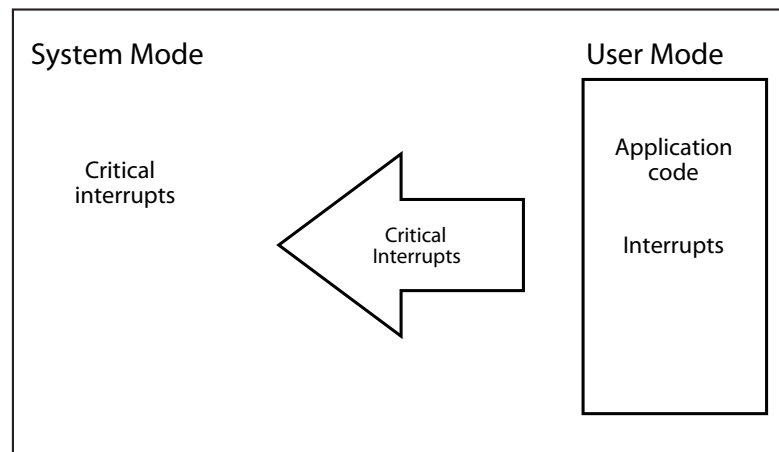

**Figure 30-1. System/User Mode Setup for Memory Protection Only**

### 30.3.2 Mixed System/User Mode Operation

This mode is similar to the previous mode, but with some portions of the program written for System Mode — for example, peripheral interrupts where latency is critical. By keeping the System Mode code sections small, potential system crashes are still minimized. Figure 30-2 shows an overview of this level of operation.

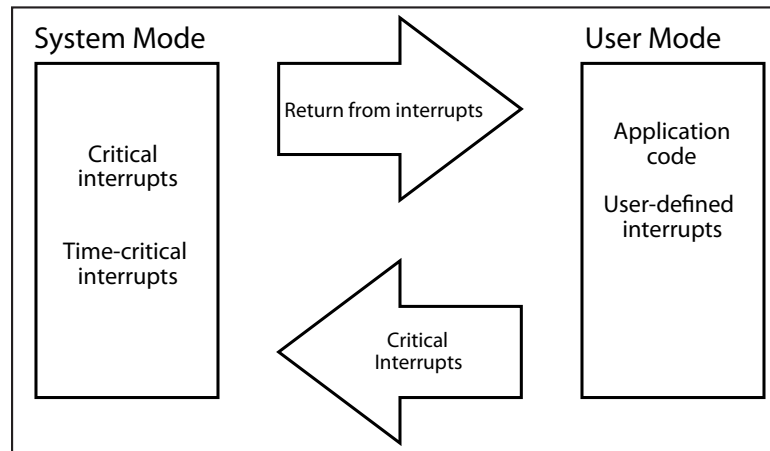

**Figure 30-2. System/User Mode Setup for Mixed Operation**

### 30.3.3 Complete Operating System

This section describes a “full” use of the System/User Mode — separating all common functions into a System Mode “operating system” while letting the application-specific code run in the User Mode. By default, the System Mode handles all peripherals and interrupts, as well as high-level interfaces such as a flash file system. However, the processor will be running the application code in the User Mode most of the time.

The application code can request direct access to a peripheral and/or interrupt from the System Mode. If allowed, the System Mode can create an interrupt vector as described in Section 30.3.7 that will execute the user code interrupt handler.

When the application code wants to perform an action that is controlled by the System Mode, it can request the particular action by loading the appropriate value into HL and executing SYSCALL. This requires generating a list of all the actions that the application code would want to do, assigning values to each action, and implementing a SYSCALL handler in the System Mode that parses the value passed to it and calls the appropriate function.

Write protection should be enabled (User Mode only) for all blocks containing system code and data as well as any critical memory regions.

If any critical interrupts occur (stack limit violation, system mode violation, write protection violation), System Mode handlers can perform any of a number of operations: restart the application code, signal another device, halt operation, and so on.

Figure 30-3 shows an overview of this level of operation.

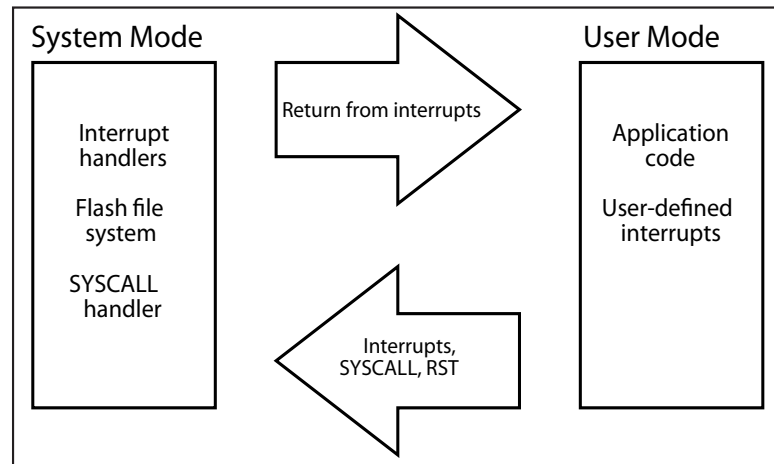

**Figure 30-3. System/User Mode Setup for Operating System**

### 30.3.4 Enabling the System/User Mode

The following steps describe how to enable the System/User Mode.

1. If a peripheral needs to be accessed while in User Mode, write to the appropriate user enable register to allow that access.
2. Write a 1 to bit 0 of EDMR to enable System/User Mode.
3. Execute the SETUSR instruction to enter User Mode.

After the User Mode is entered, the limitations described earlier are in effect — writes to protected registers will be ignored, Priority 3 is not available, and executing an IDET will cause a System Mode Violation interrupt. Other features such as write protection may be effect for user mode as well.

### 30.3.5 System/User Mode Instructions

Seven instructions exist primarily to support the System/User Mode, and are listed in Table 30-3. Note that **IDET** shares the value of **LD E, E** in the opcode table, and will always perform that operation (but will have special behavior when the System/User Mode is enabled and the processor is in System Mode). In addition, if the ALTD prefix appears before the instruction, **LD E', E** is always executed and the special behavior does not occur.

**Table 30-3. System/User Mode Instructions**

Instruction	Bytes	clk	A	I	S	Z	V	C	Operation	Priv
<b>SETUSR</b>	2	4		-	-	-	-	-	SU = {SU[5:0], 0x01}	Yes
<b>PUSH SU</b>	2	9		-	-	-	-	-	(SP-1) = SU; SP = SP - 1	Yes
<b>POP SU</b>	2	7		-	-	-	-	-	SU = (SP); SP = SP + 1	Yes
<b>SURES</b>	2	4		-	-	-	-	-	SU = {SU[1:0], SU[7:2]}	Yes
<b>IDET</b>	1	2		-	-	-	-	-	Performs <b>LD E, E</b> , but if (EDMF && SU[0]) then the System Violation interrupt flag is set; if ALTD appears before it always does <b>LD E', E</b>	No
<b>RDMODE</b>	2	4		-	-	-	-	*	CF = SU[0]	Yes
<b>SYSCALL</b>	2	10		-	-	-	-	-	SP = SP - 2; PC = {R,v} where v = SYSCALL offset	No
<b>SCALL</b>	2	15		-	-	-	-	-	(SP-1) = PCH; (SP-2) = PCL; (SP-3) = SU; SP = SP - 3; PC = {IIR, 01100000}; SU = {SU[5:0], 00}	No
<b>SRET</b>	2	12		-	-	-	-	-	SU = (SP); PCL = (SP+1); PCH = (SP+2); SP = SP+3	No
<b>SETUSR<sub>P mn</sub></b>	4	15		-	-	-	-	-	SU = {SU[7:2], 01}, (SP-1) = m; (SP-2) = n; SP = SP-2	No
<b>SETSUSP<sub>mn</sub></b>	4	12		-	-	-	-	-	SU = {SU[1:0], SU[7:2]}; tmp1 = (SP); tmp2 = (SP+1); SP = SP+2; if {tmp != mn} System Violation	No

The processor keeps a one-byte stack (called the SU register) that is analogous to the IP register that keeps track of the interrupt priority. Every time **SETUSR** is executed (to enter the User Mode), or an interrupt occurs, or **SYSCALL** or **RST** is executed (to enter System Mode), the current mode is pushed onto the SU register. When a **SURES** is executed, the previous mode is popped off the SU register.

The effects of each instruction are:

- The **SETUSR** instruction puts the processor into the User Mode by pushing the correct value into the SU register.
- **PUSH SU** and **POP SU** push and pop the single-byte SU register on/off the SP stack.
- **SURES** pops the current processor mode off the SU register, returning it to the previous mode.
- **IDET** causes an interrupt if executed in the User Mode, and does nothing in System Mode. It is intended to be placed in system-level code and trap any execution of that code while in the User Mode.
- **RDMODE** returns the current mode in the carry flag (0 for System Mode, 1 for User Mode).
- **SYSCALL** is essentially a new **RST** instruction, and was added to allow User Mode access to the System Mode without using one of the existing **RST** instructions. It will put the processor into the System Mode and execute code in the corresponding interrupt-vector table entry.
- **SCALL** is another **RST** instruction that vectors to the same address as **SYSCALL**. The difference is that it also pushes the value of the SU register as well as the return address onto the stack.
- **SRET** is the companion instruction to **SCALL**; it expects both SU and the return address to be on the stack.
- **SETSYSP** and **SETUSRP** are support functions for handing user mode interrupts. **SETSYSP** pushes a 16-bit compare value onto the stack and enters user mode. **SETSYSP** pops a 16-bit value off the stack and compares it to the provided value; a system mode violation interrupt occurs if they do not match. These two instructions provide protection for User Mode interrupts by checking for both main stack and SU stack mismatches when the User Mode handler returns.

### 30.3.6 System Mode Violation Interrupt

The following steps describe how to set up the System Mode Violation interrupt.

1. Write the vector to the interrupt service routine to the internal interrupt table.
2. Enable the system/user mode by writing to EDMR.
3. The interrupt request is cleared automatically when handled.

A sample interrupt handler is shown below.

```
sysmode_isr::
    push af
    ; handle the system mode violation here
    pop af
    sures
    ipres
    ret
```

### 30.3.7 Handling Interrupts in the System/User Mode

Interrupts, **RSTs**, **SYSCALL**, and **SCALL** all enter the System Mode automatically. There will be times, however, that an interrupt should be handled in the User Mode. The solution to this is for System Mode interrupt vector to reenter the User Mode before calling the User Mode interrupt handler. An example of both system and user interrupt handling is shown in Figure 30-4.

When enabled for User Mode access, a peripheral interrupt (if it is capable of generating an interrupt) can only be requested at Priority 2 or 1.

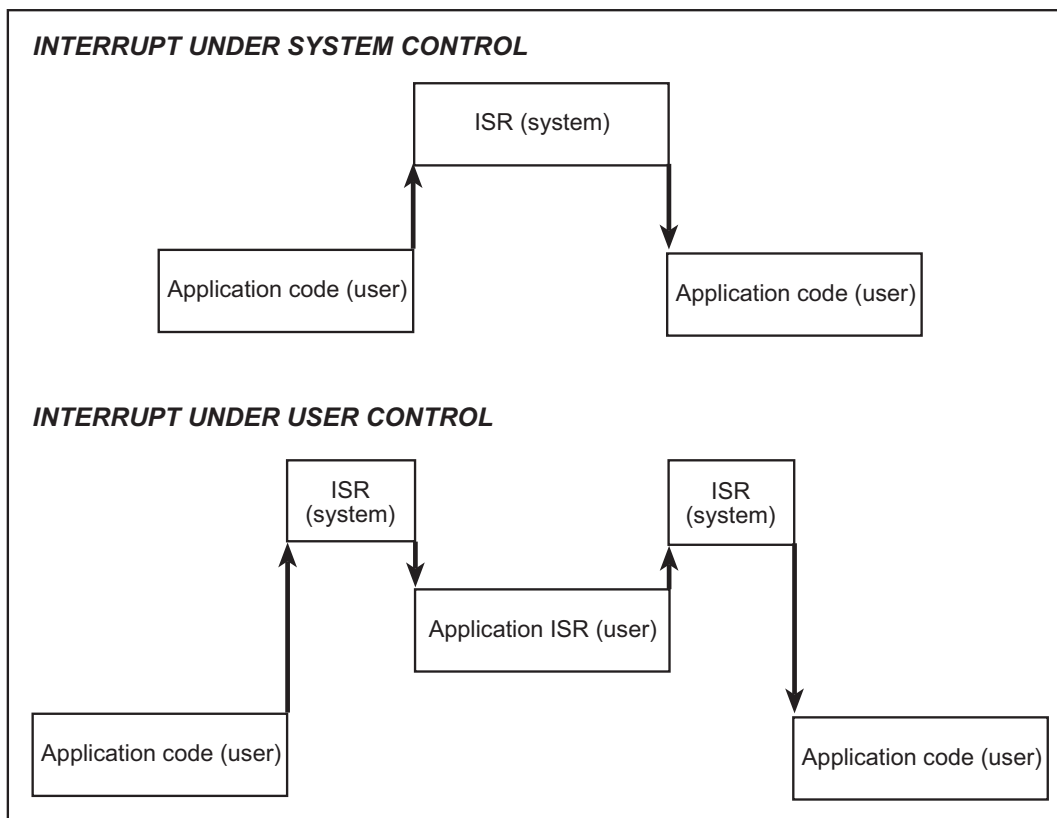

**Figure 30-4. Interrupt Handling in the System/User Mode**

Some sample code for both System Mode interrupts and User Mode interrupts is shown below. The use of **SETUSRP** and **SETSISP** provides checks against stack mismatches and incorrect System/User Modes coming out of the User Mode handler.

```
systemmode_isr:                ; jumped to from interrupt vector table
    ... handle interrupt ...
    sures                      ; reenter previous mode
    ipres                      ; restore previous interrupt priority
    ret

usermode_isr:                  ; jumped to from interrupt vector table
                                ;   (still in system mode at this point)
    push su                    ; preserve current SU stack
    setusrp 0x1234              ; enter user mode with stack compare value
    call user_handler          ; handle interrupt at user level
    setsisp 0x1234             ; return to system mode
    sures                      ; reenter previous mode
    ipres                      ; restore previous interrupt priority
    ret
```

## 30.4 Register Descriptions

<b>Real-Time Clock User Enable Register (RTUER) (Address = 0x0300)</b>		
<b>Bit(s)</b>	<b>Value</b>	<b>Description</b>
7	0	Disable User Mode access to the RTC (I/O addresses 0x0002–0x0007).
	1	Enable User Mode access to the RTC (I/O addresses 0x0002–0x0007).
6:0		These bits are reserved and should be written with zeros.

<b>Slave Port User Enable Register (SPUER) (Address = 0x0320)</b>		
<b>Bit(s)</b>	<b>Value</b>	<b>Description</b>
7	0	Disable User Mode access to the slave port (I/O addresses 0x0020–0x0027).
	1	Enable User Mode access to the slave port (I/O addresses 0x0020–0x0027).
6:0		These bits are reserved and should be written with zeros.

<b>Parallel Port A User Enable Register (PAUER) (Address = 0x0330)</b>		
<b>Bit(s)</b>	<b>Value</b>	<b>Description</b>
7	0	Disable User Mode access to Parallel Port A (I/O addresses 0x0030–0x0037).
	1	Enable User Mode access to Parallel Port A (I/O addresses 0x0030–0x0037).
6:0		These bits are reserved and should be written with zeros.

<b>Parallel Port H User Enable Register (PHUER) (Address = 0x0332)</b>		
<b>Bit(s)</b>	<b>Value</b>	<b>Description</b>
7	0	Disable User Mode access to Parallel Port H (I/O addresses 0x0032–0x0037).
	1	Enable User Mode access to Parallel Port H (I/O addresses 0x0032–0x0037).
6:0		These bits are reserved and should be written with zeros.

<b>Parallel Port B User Enable Register (PBUER) (Address = 0x0340)</b>		
<b>Bit(s)</b>	<b>Value</b>	<b>Description</b>
7	0	Disable User Mode access to Parallel Port B (I/O addresses 0x0040–0x0047).
	1	Enable User Mode access to Parallel Port B (I/O addresses 0x0040–0x0047).
6:0		These bits are reserved and should be written with zeros.



<b>Parallel Port C User Enable Register (PCUER) (Address = 0x0350)</b>		
<b>Bit(s)</b>	<b>Value</b>	<b>Description</b>
7	0	Disable User Mode access to Parallel Port C (I/O addresses 0x0050–0x0055).
	1	Enable User Mode access to Parallel Port C (I/O addresses 0x0050–0x0055).
6:0		These bits are reserved and should be written with zeros.

<b>Parallel Port D User Enable Register (PDUER) (Address = 0x0360)</b>		
<b>Bit(s)</b>	<b>Value</b>	<b>Description</b>
7	0	Disable User Mode access to Parallel Port D (I/O addresses 0x0060–0x006F).
	1	Enable User Mode access to Parallel Port D (I/O addresses 0x0060–0x006F).
6:0		These bits are reserved and should be written with zeros.

<b>Parallel Port E User Enable Register (PEUER) (Address = 0x0370)</b>		
<b>Bit(s)</b>	<b>Value</b>	<b>Description</b>
7	0	Disable User Mode access to Parallel Port E (I/O addresses 0x0070–0x007F).
	1	Enable User Mode access to Parallel Port E (I/O addresses 0x0070–0x007F).
6:0		These bits are reserved and should be written with zeros.

<b>Input Capture User Enable Register (ICUER) (Address = 0x0358)</b>		
<b>Bit(s)</b>	<b>Value</b>	<b>Description</b>
7	0	Disable User Mode access to input capture (I/O addresses 0x0056–0x005F).
	1	Enable User Mode access to input capture (I/O addresses 0x0056–0x005F).
6:0		These bits are reserved and should be written with zeros.

<b>I/O Bank User Enable Register (IBUER) (Address = 0x0380)</b>		
<b>Bit(s)</b>	<b>Value</b>	<b>Description</b>
7	0	Disable User Mode access to I/O Bank 7 (and internal I/O address 0x0087).
	1	Enable User Mode access to I/O Bank 7 (and internal I/O addresses 0x0087).
6	0	Disable User Mode access to I/O Bank 6 (and internal I/O address 0x0086).
	1	Enable User Mode access to I/O Bank 6 (and internal I/O addresses 0x0086).
5	0	Disable User Mode access to I/O Bank 5 (and internal I/O address 0x0085).
	1	Enable User Mode access to I/O Bank 5 (and internal I/O addresses 0x0085).
4	0	Disable User Mode access to I/O Bank 4 (and internal I/O address 0x0084).
	1	Enable User Mode access to I/O Bank 4 (and internal I/O addresses 0x0084).
3	0	Disable User Mode access to I/O Bank 3 (and internal I/O address 0x0083).
	1	Enable User Mode access to I/O Bank 3 (and internal I/O addresses 0x0083).
2	0	Disable User Mode access to I/O Bank 2 (and internal I/O address 0x0082).
	1	Enable User Mode access to I/O Bank 2 (and internal I/O addresses 0x0082).
1	0	Disable User Mode access to I/O Bank 1 (and internal I/O address 0x0081).
	1	Enable User Mode access to I/O Bank 1 (and internal I/O addresses 0x0081).
0	0	Disable User Mode access to I/O Bank 0 (and internal I/O address 0x0080).
	1	Enable User Mode access to I/O Bank 0 (and internal I/O addresses 0x0080).

<b>PWM User Enable Register (PWUER) (Address = 0x0388)</b>		
<b>Bit(s)</b>	<b>Value</b>	<b>Description</b>
7	0	Disable User Mode access to the PWM (I/O addresses 0x0088–0x008F and 0x00E8–0x00E9).
	1	Enable User Mode access to the PWM (I/O addresses 0x0088–0x008F and 0x00E8–0x00E9).
6:0		These bits are reserved and should be written with zeros.

<b>Quad Decode User Enable Register (QDUER) (Address = 0x0390)</b>		
<b>Bit(s)</b>	<b>Value</b>	<b>Description</b>
7	0	Disable User Mode access to the Quadrature Decoder (I/O addresses 0x0090–0x0097).
	1	Enable User Mode access to the Quadrature Decoder (I/O addresses 0x0090–0x0097).
6:0		These bits are reserved and should be written with zeros.

<b>External Interrupt User Enable Register (IUER) (Address = 0x0398)</b>		
<b>Bit(s)</b>	<b>Value</b>	<b>Description</b>
7:2		These bits are reserved and should be written with zeros.
1	0	Disable User Mode access to External Interrupt 1 (I/O address 0x0099).
	1	Enable User Mode access to External Interrupt 1 (I/O addresses 0x0099).
0	0	Disable User Mode access to External Interrupt 0 (I/O address 0x0098).
	1	Enable User Mode access to External Interrupt 0 (I/O addresses 0x0098).

<b>Timer A User Enable Register (TAUER) (Address = 0x03A0)</b>		
<b>Bit(s)</b>	<b>Value</b>	<b>Description</b>
7	0	Disable User Mode access to Timer A (I/O addresses 0x00A0–0x00AF).
	1	Enable User Mode access to Timer A (I/O addresses 0x00A0–0x00AF).
6:0		These bits are reserved and should be written with zeros.

<b>Analog User Enable Register (AUER) (Address = 0x03A8)</b>		
<b>Bit(s)</b>	<b>Value</b>	<b>Description</b>
7:3		These bits are reserved and should be written with zeros.
2	0	Disable User Mode access to Analog Channel 2 (I/O addresses 0x0820–0x082F).
	1	Enable User Mode access to Analog Channel 2 (I/O addresses 0x0820–0x082F).
1	0	Disable User Mode access to Analog Channel 1 (I/O addresses 0x0810–0x081F).
	1	Enable User Mode access to Analog Channel 1 (I/O addresses 0x0810–0x081F).
0	0	Disable User Mode access to Analog Channel 0 (I/O addresses 0x0800–0x080F).
	1	Enable User Mode access to Analog Channel 0 (I/O addresses 0x0800–0x080F).

<b>Timer B User Enable Register (TBUER) (Address = 0x03B0)</b>		
<b>Bit(s)</b>	<b>Value</b>	<b>Description</b>
7	0	Disable User Mode access to Timer B (I/O addresses 0x00B0–0x00BF).
	1	Enable User Mode access to Timer B (I/O addresses 0x00B0–0x00BF).
6:0		These bits are reserved and should be written with zeros.

<b>Timer C User Enable Register (TCUER) (Address = 0x03F8)</b>		
<b>Bit(s)</b>	<b>Value</b>	<b>Description</b>
7	0	Disable User Mode access to Timer C (I/O addresses 0x0500–0x050F and 0x00F8–0x00F9).
	1	Enable User Mode access to Timer C (I/O addresses 0x0500–0x050F and 0x00F8–0x00F9).
6:0		These bits are reserved and should be written with zeros.

<b>Serial Port A User Enable Register (SAUER) (Address = 0x03C0)</b>		
<b>Bit(s)</b>	<b>Value</b>	<b>Description</b>
7	0	Disable User Mode access to Serial Port A (I/O addresses 0x00C0–0x00C7).
	1	Enable User Mode access to Serial Port A (I/O addresses 0x00C0–0x00C7).
6:0		These bits are reserved and should be written with zeros.

<b>Serial Port B User Enable Register (SBUER) (Address = 0x03D0)</b>		
<b>Bit(s)</b>	<b>Value</b>	<b>Description</b>
7	0	Disable User Mode access to Serial Port B (I/O addresses 0x00D0–0x00D7).
	1	Enable User Mode access to Serial Port B (I/O addresses 0x00D0–0x00D7).
6:0		These bits are reserved and should be written with zeros.

<b>Serial Port C User Enable Register (SCUER) (Address = 0x03E0)</b>		
<b>Bit(s)</b>	<b>Value</b>	<b>Description</b>
7	0	Disable User Mode access to Serial Port C (I/O addresses 0x00E0–0x00E7).
	1	Enable User Mode access to Serial Port C (I/O addresses 0x00E0–0x00E7).
6:0		These bits are reserved and should be written with zeros.

<b>Serial Port D User Enable Register (SDUER) (Address = 0x03F0)</b>		
<b>Bit(s)</b>	<b>Value</b>	<b>Description</b>
7	0	Disable User Mode access to Serial Port D (I/O addresses 0x00F0–0x00F7).
	1	Enable User Mode access to Serial Port D (I/O addresses 0x00F0–0x00F7).
6:0		These bits are reserved and should be written with zeros.

<b>Serial Port E User Enable Register (SEUER) (Address = 0x03C8)</b>		
<b>Bit(s)</b>	<b>Value</b>	<b>Description</b>
7	0	Disable User Mode access to Serial Port E (I/O addresses 0x00C8–0x00CF).
	1	Enable User Mode access to Serial Port E (I/O addresses 0x00C8–0x00CF).
6:0		These bits are reserved and should be written with zeros.

<b>Serial Port F User Enable Register (SFUER) (Address = 0x03D8)</b>		
<b>Bit(s)</b>	<b>Value</b>	<b>Description</b>
7	0	Disable User Mode access to Serial Port F (I/O addresses 0x00D8–0x00DF).
	1	Enable User Mode access to Serial Port F (I/O addresses 0x00D8–0x00DF).
6:0		These bits are reserved and should be written with zeros.

<b>Enable Dual-Mode Register (EDMR) (Address = 0x0420)</b>		
<b>Bit(s)</b>	<b>Value</b>	<b>Description</b>
7:6	00	Default (Rabbit 2000/3000) instruction set.
	01	This bit combination is reserved and must not be used.
	10	This bit combination is reserved and must not be used.
	11	Enhanced (Rabbit 5000) instruction set.
5:1		These bits are reserved and should be written with zeros.
0	0	Normal (System Mode only) operation.
	1	Enable System/User Mode operation.



# 31. SPECIFICATIONS

## 31.1 DC Characteristics

**Table 31-1. Preliminary DC Electrical Characteristics**

Parameter		Symbol	Min	Typ	Max
Operating Temperature		$T_A$	-40°C		85°C
Storage Temperature			-55°C		125°C
Core	Core Supply Voltage	$V_{DD_{CORE}}$	1.65 V	1.8 V	1.90 V
	Core Current @ 100 MHz, Wi-Fi enabled, 25°C	$I_{CORE}$		194 mA	
	Core Current @ 100 MHz, Wi-Fi disabled, 25°C			32 mA	
	Core Current @ 50 MHz, Wi-Fi disabled, 25°C			17 mA	
	Core Current @ 32.768 kHz, Wi-Fi disabled, 25°C			2 mA	
I/O Ring	I/O Ring Supply Voltage, 3.3 V	$V_{DD_{IO}}$	3.0 V	3.3 V	3.6 V
	I/O Ring Current @ 88.4736 MHz, 25°C	$I_{IO}$		22 mA	
	I/O Ring Current @ 29.4912 MHz, 25°C			12 mA	
	I/O Ring Current @ 32.768 kHz, 25°C			5 mA	
	Input Low Voltage	$V_{IL}$			0.8 V
	Input High Voltage	$V_{IH}$	2.0 V		
	Output Low Voltage	$V_{OL}$		0.0 V	0.4 V
	Output High Voltage	$V_{OH}$	2.4 V	3.3 V	
Output drive: A[19:0], /CS[2:0], /OE[1:0], WE[1:0] D[7:0] /IOWR, /IORD, /IOBEN PA[7:0], PB[7:0], PC[7:0], PD[7:0], PH[7:0] PE[7:0] All other pins	$I_{DRIVE}$			16 mA 8 mA 16 mA 8 mA 16 mA 8 mA	

**Table 31-2. Preliminary Battery-Backed DC Electrical Characteristics**  
**( $V_{DD_{CORE}} = 1.8V \pm 10\%$ ,  $V_{DD_{IO}} = 3.3V \pm 10\%$ ,  $T_A = -40^\circ C$  to  $85^\circ C$ )**

Parameter		Symbol	Min	Typ	Max
VBAT	VBAT Supply Voltage	VBAT	1.65 V	1.8 V	1.90 V
	VBAT Current (rest of device powered) (rest of device powered down)	$I_{VBAT}$		22 $\mu A$ 290 nA	
VBATIO	VBATIO Supply Voltage (rest of device powered) (rest of device powered down)	VBATIO	1.65 V 1.65 V	3.3 V 1.8 V	3.6 V 3.6 V
	VBATIO Current (rest of device powered) (rest of device powered down)	$I_{VBATIO}$		200 nA 200 nA	



## 31.2 AC Characteristics

**Table 31-3. Preliminary AC Electrical Characteristics**  
( $VDD_{CORE} = 1.8\text{ V} \pm 10\%$ ,  $VDD_{IO} = 3.3\text{ V} \pm 10\%$ ,  $T_A = -40^\circ\text{C to } 85^\circ\text{C}$ )

Parameter	Symbol	Min	Typ	Max
Main Clock Frequency on CLKI	$f_{\text{main}}$			100 MHz
Real-Time Clock Frequency on CLK32K	$f_{\text{RTC}}$		32.768 kHz	
Ethernet Clock Frequency	$f_{\text{Eth}}$	25 MHz $\pm$ 100 ppm		
Wi-Fi Clock Frequency	$f_{\text{WiFi}}$	20 MHz $\pm$ 100 ppm		

## 31.3 Memory Access Times

All access time measurements are taken at 50% of signal height.

### 31.3.1 Memory Reads

**Table 31-4. Preliminary Memory Read Time Delays**  
( $VDD_{CORE} = 1.8\text{ V} \pm 10\%$ ,  $VDD_{IO} = 3.3\text{ V} \pm 10\%$ ,  $T_A = -40^\circ\text{C to }85^\circ\text{C}$ )

Parameter	Symbol	Min	Typ	Max
Clock to Address Delay	$T_{\text{adr}}$	3 ns		8 ns
Clock to Memory Chip Select Delay	$T_{\text{CSx}}$	3 ns		6 ns
Clock to Memory Read Strobe Delay	$T_{\text{OEx}}$	3 ns		6 ns
Data Setup Time	$T_{\text{setup}}$		1 ns	
Data Hold Time	$T_{\text{hold}}$		0 ns	

### 31.3.2 Memory Writes

**Table 31-5. Preliminary Memory Write-Time Delays**  
( $VDD_{CORE} = 1.8\text{ V} \pm 10\%$ ,  $VDD_{IO} = 3.3\text{ V} \pm 10\%$ ,  $T_A = -40^\circ\text{C to }85^\circ\text{C}$ )

Parameter	Symbol	Min	Typ	Max
Clock to Address Delay	$T_{\text{adr}}$	3 ns		8 ns
Clock to Memory Chip Select Delay	$T_{\text{CSx}}$	3 ns		6 ns
Clock to Memory Write Strobe Delay	$T_{\text{WEx}}$	3 ns		6 ns
High Z to Data Valid Relative to Clock	$T_{\text{DVHZ}}$	3 ns		8 ns
Data Valid to High Z Relative to Clock	$T_{\text{DVHZ}}$	3 ns		8 ns

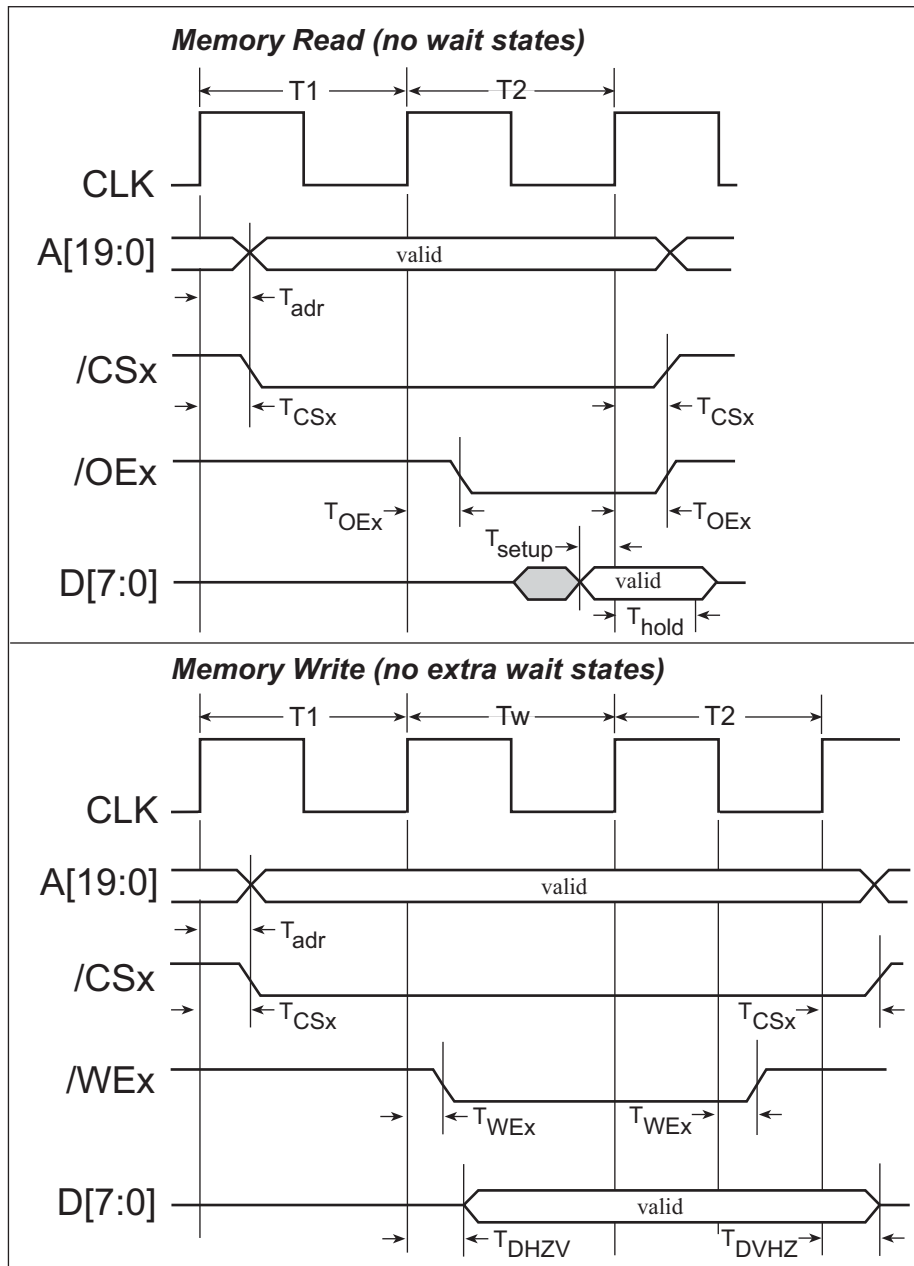

**Figure 31-1. Memory Read and Write Cycles**

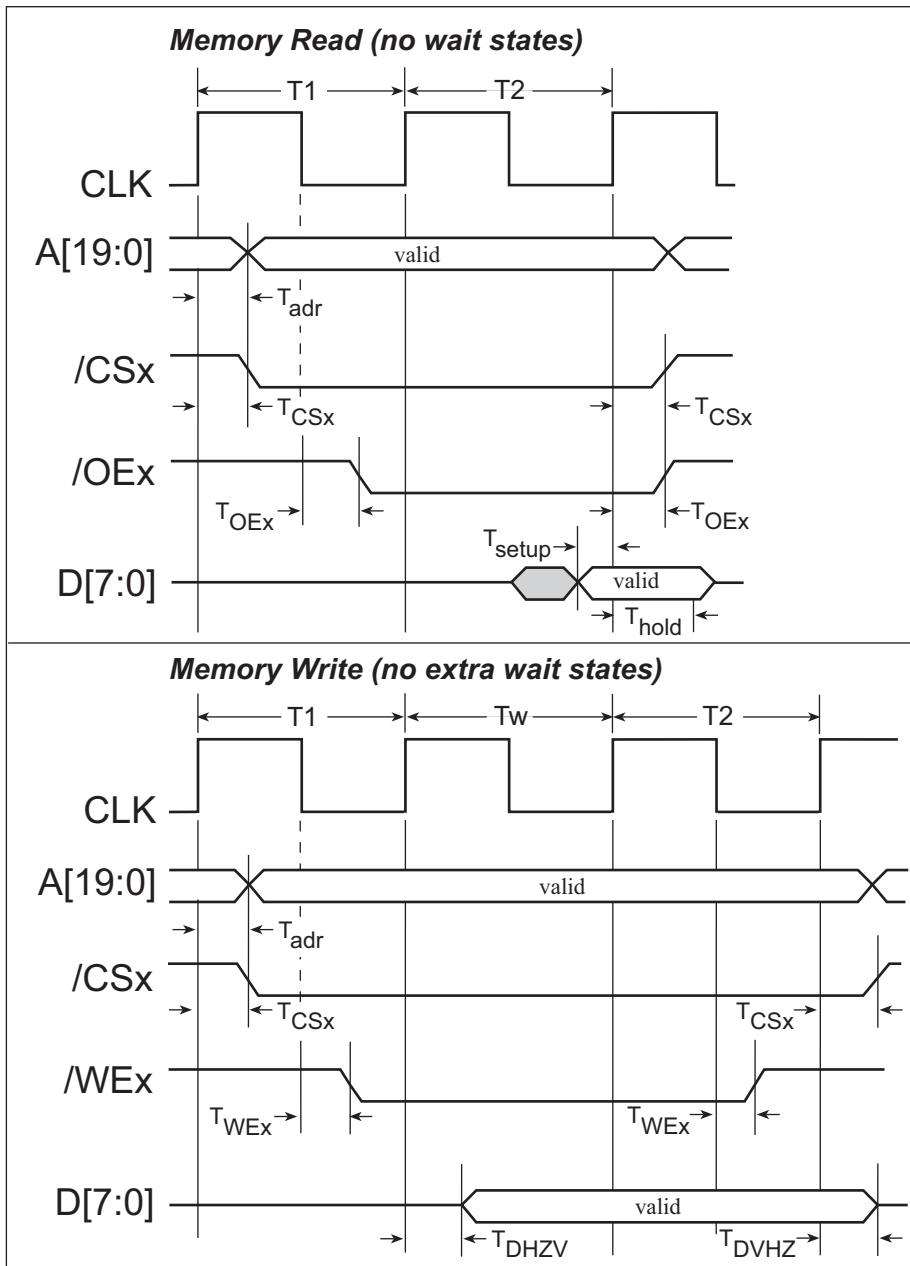

**Figure 31-2. Memory Read and Write Cycles—Early Output Enable and Write Enable Timing**

### 31.3.3 External I/O Reads

**Table 31-6. Preliminary External I/O Read Time Delays**  
*(VDD<sub>CORE</sub> = 1.8 V ± 10%, VDD<sub>IO</sub> = 3.3 V ± 10%, T<sub>A</sub> = -40° C to 85° C)*

Parameter	Symbol	Min	Typ	Max
Clock to Address Delay	T <sub>adr</sub>	4 ns		8 ns
Clock to Memory Chip Select Delay	T <sub>CSx</sub>	3 ns		6 ns
Clock to I/O Chip Select Delay	T <sub>IOCSx</sub>	4 ns		10 ns
Clock to I/O Read Strobe Delay	T <sub>IORD</sub>	3 ns		7 ns
Clock to I/O Buffer Enable Delay	T <sub>BUFEN</sub>	3 ns		6 ns
Data Setup Time	T <sub>setup</sub>		1 ns	
Data Hold Time	T <sub>hold</sub>		1 ns	

### 31.3.4 External I/O Writes

**Table 31-7. Preliminary External I/O Write Time Delays**  
*(VDD<sub>CORE</sub> = 1.8 V ± 10%, VDD<sub>IO</sub> = 3.3 V ± 10%, T<sub>A</sub> = -40° C to 85° C)*

Parameter	Symbol	Min	Typ	Max
Clock to Address Delay	T <sub>adr</sub>	4 ns		8 ns
Clock to Memory Chip Select Delay	T <sub>CSx</sub>	3 ns		6 ns
Clock to I/O Chip Select Delay	T <sub>IOCSx</sub>	4 ns		10 ns
Clock to I/O Write Strobe Delay	T <sub>IOWR</sub>	3 ns		7 ns
Clock to I/O Buffer Enable Delay	T <sub>BUFEN</sub>	3 ns		6 ns
High Z to Data Valid Relative to Clock	T <sub>DHZV</sub>	3 ns		6 ns
Data Valid to High Z Relative to Clock	T <sub>DVHZ</sub>	1 ns		2 ns

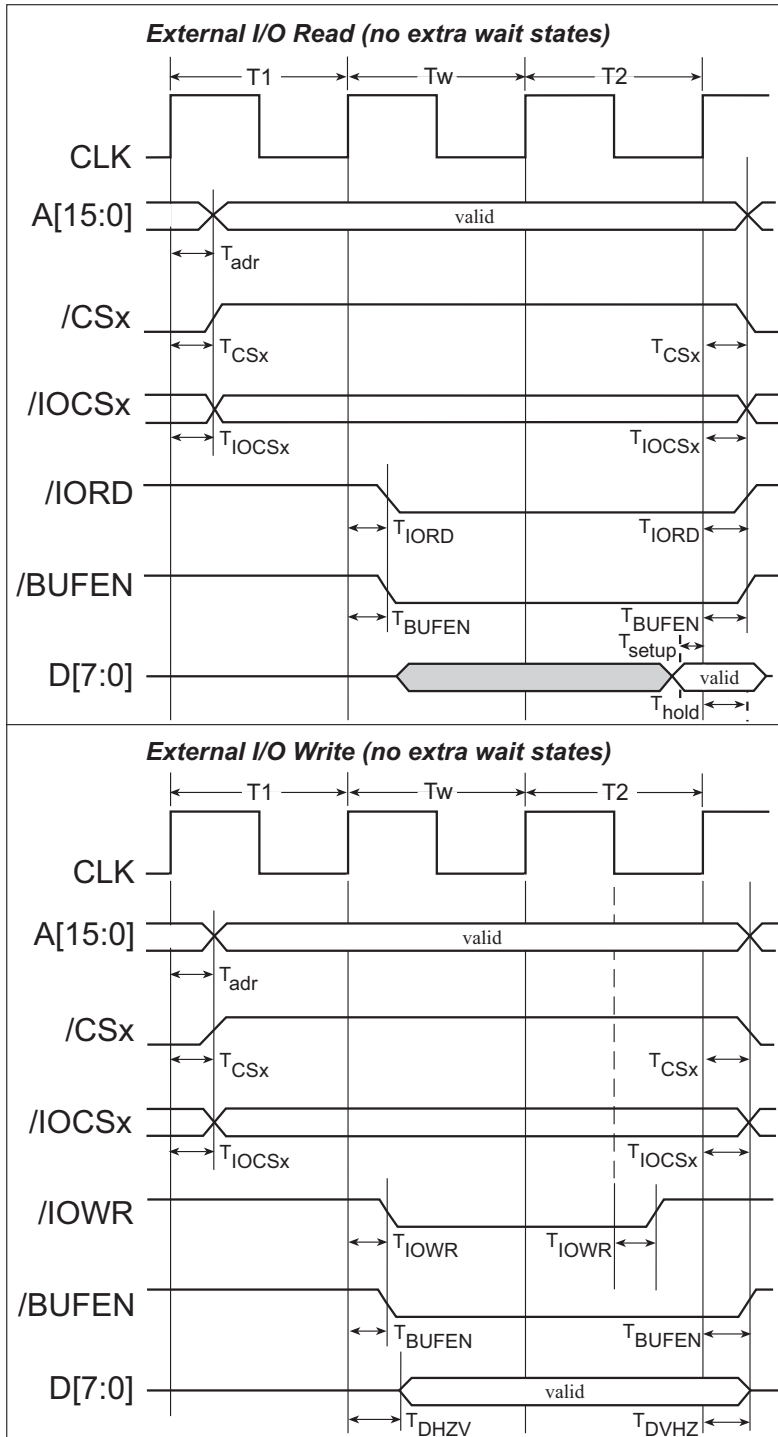

**Figure 31-3. I/O Read and Write Cycles—No Extra Wait States**

**NOTE:** **/IOCSx** can be programmed to be active low (default) or active high.

### 31.3.5 Memory Access Times

In computing memory requirements, the important considerations are the address access time, output-enable access time, and minimum write-pulse required. Increasing the clock doubler delay increases the output-enable time, but decreases the memory write-pulse width. The early write-pulse option can be used to ensure a long-enough write pulse, but then it must be ensured that the write pulse does not begin before the address lines have stabilized.

The clock doubler has an affect on the memory access times. It works by ORing the clock with a delayed version of itself. The nominal delay varies from 3 to 20 ns, and is set under program control. Any asymmetry in the main clock input before it is doubled will result in alternate clocks having slightly different periods. Using the suggested oscillator circuit, the asymmetry is no worse than 52%–48%. This results in a given clock being shortened by the ratio 50/52, or 4% worst-case. The memory access time is not normally affected because the memory bus cycle is two clocks long and includes both a long and a short clock, resulting in no net change arising from asymmetry. However, if an odd number of wait states is used, then the memory access time will be affected slightly.

When the clock spectrum spreader is enabled, clock periods are shortened by a small amount, depending on whether the “normal” or the “strong” spreader setting is used, and depending on the operating voltage. If the clock doubler is used, the spectrum spreader affects every other cycle and reduces the clock high time. If the doubler is not used, then the spreader affects every clock cycle, and the clock low time is reduced. Of course, the spectrum spreader also lengthens clock cycles, but only the worst-case shortening is relevant for calculating worst-case access times. The numbers given for clock shortening with the doubler disabled are the combined shortening for two consecutive clock cycles, worst case.

The required memory address and output-enable access time for some typical clock speeds are given in Table 31-8 below. It is assumed that the clock doubler is used, that the clock spreader is enabled in the normal mode, that the memory early output-enable is on, and that the address bus has a load of 60 pF.

**Table 31-8. Preliminary Memory Requirements**  
*(VDD<sub>CORE</sub> = 1.8 V ± 10%, VDD<sub>IO</sub> = 3.3 V ± 10%, T<sub>A</sub> = -40° C to 85° C,  
 address bus loading = 60 pF)*

Clock Frequency (MHz)	Period (ns)	Clock Doubler Nominal Delay (ns)	Memory Address Access (ns)	Memory Output-Enable Access (ns)
22.11	45	20	78	51
29.49	34	16	56	36
44.24	22.5	10	33.5	22
58.98	17	6	22	19

All important signals on the Rabbit 5000 are output-synchronized with the internal clock. The internal clock is closely synchronized with the external clock, which is available on the CLK pin. The delay in signal output depends on the capacitive load on the output lines. In the case of the address lines, which are critically important for establishing memory access time requirements, the capacitive loading is usually in the range of 25–100 pF, and the load is due to the input capacitance of the memory devices and PC trace capacitance.

Delays are expressed from the waveform midpoint in keeping with the convention used by memory manufacturers.

Table 31-9 lists the delays in gross memory access time for several values of  $V_{DDIO}$ .

**Table 31-9. Preliminary Data and Clock Delays**  
( $V_{DD} \pm 10\%$ , Temp.  $-40^{\circ}C$  to  $85^{\circ}C$ )

$V_{DDIO}$ (V)	Clock to Address Output Delay (ns)	Data Setup Time Delay (ns)	Worst-Case Spectrum Spreader Delay (ns)		
			0.5 ns setting no dbl / dbl	1 ns setting no dbl / dbl	2 ns setting no dbl / dbl
3.3	6	1	2.3 / 2.3	3 / 4.5	4.5 / 9

When the spectrum spreader is enabled with the clock doubler, every other clock cycle is shortened or lengthened by a maximum amount given in the table above. The shortening takes place by shortening the high part of the clock. If the doubler is not enabled, then every clock is shortened during the low part of the clock period. The maximum shortening for a pair of clocks combined is shown in the table.

The gross memory access time is  $2T$ , where  $T$  is the clock period. To calculate the actual memory access time, subtract the clock to address output time, the data in setup time, and the clock period shortening due to the clock spectrum spreader from  $2T$ .

#### Example Memory Access Time Calculation

- clock = 29.49 MHz, so  $T = 34$  ns
- clock to address output delay = 6 ns (see Table 31-9)
- data setup time = 1 ns
- spectrum spreader is on in 1 ns mode, resulting in a loss of 3 ns worst-case (see Table 31-9)

The access time is given by

$$\begin{aligned}
 \text{access time} &= 2T - (\text{clock to address}) - (\text{data setup}) - (\text{spreader delay}) \\
 &= 68 \text{ ns} - 6 \text{ ns} - 1 \text{ ns} - 3 \text{ ns} \\
 &= 58 \text{ ns}
 \end{aligned}$$

Similarly, the gross output-enable access time is  $T$  + minimum clock low time (it is assumed that the early output enable option is enabled). This is reduced by the spectrum



spreader loss, the time from clock to output for the output enable signal, the data setup time, and a correction for the asymmetry of the original oscillator clock.

### Example Output-Enable Access Time Calculation

**NOTE:** There is some process and temperature variation in the clock doubler settings. As a rule of thumb, a 20% variation should be considered. When the doubler is enabled, 80% of the nominal value should be used for the memory access time calculation.

- clock = 29.49 MHz, so  $T = 34$  ns
- the clock doubler has a nominal delay of 16 ns (see Table 31-8), resulting in a minimum clock low time of  $80\% \times 16$  ns = 12.8 ns
- clock to output enable is 5 ns
- spectrum spreader is on in 1 ns mode, resulting in a loss of 4.5 ns worst-case (see Table 31-9)
- main clock asymmetry is 52% / 48%, resulting in a loss of 4% of the clock period, or 1.4 ns

The output enable access time is given by

$$\begin{aligned} \text{access time} &= T + (\text{min. clock low}) - (\text{clock to output enable}) - \\ &\quad (\text{spreader delay}) - (\text{asymmetry delay}) - (\text{data setup time}) \\ &= 34 \text{ ns} + 12.8 \text{ ns} - 5 \text{ ns} - 4.5 \text{ ns} - 1.4 \text{ ns} \\ &= 36 \text{ ns} \end{aligned}$$

## 31.4 Clock Speeds

### 31.4.1 Recommended Clock/Memory Configurations

The preferred configuration for a Rabbit-based system is to use an external crystal or resonator that has a frequency one-half of the maximum internal clock frequency. The oscillator frequency can be doubled or divided by 2, 4, 6, or 8, giving a variety of operating speeds from the same crystal frequency. In addition, the 32.768 kHz oscillator that drives the battery-backable clock can be used as the main processor clock and, to save the substantial power consumed by the fast oscillator, the fast oscillator can be turned off. This scenario is called the *sleepy mode*, where the clock speed is from 2 kHz to 32 kHz.

Table 31-10 describes some recommended clock and memory configurations for both 8-bit and 16-bit memory devices. Optimal configurations for using 12 ns, 15 ns, 45–55 ns, and 70 ns memories are shown. Note that there is always at least one wait state in the 16-bit mode.

**Table 31-10. Some Recommended Clock/Memory Configurations**

Input Frequency (MHz)	Internal Frequency (MHz)	Recommended Memory Timing		Optimal Use
		8-bit Devices	16-bit Devices (1 wait state min.)	
44.2368	88.4736	12 ns, 0 wait states 15 ns, 1 wait state 45 ns, 4 wait states 55 ns, 4 wait states 70 ns not possible	12 ns, 1 wait state 15 ns, 2 wait state 45 ns, 4 wait states 55 ns, 5 wait states 70 ns, 6 wait states	12 ns devices
36.8640	73.7280	12 ns, 0 wait states 15 ns, 0 wait states 45 ns, 2 wait states 55 ns, 4 wait states 70 ns, 4 wait states	12 ns, 1 wait state 15 ns, 1 wait state 45 ns, 4 wait states 55 ns, 4 wait states 70 ns, 5 wait states	15 ns devices
18.4320	36.8640	12 ns, 0 wait states 15 ns, 0 wait states 45 ns, 0 wait states 55 ns, 1 wait state 70 ns, 1 wait state	12 ns, 1 wait state 15 ns, 1 wait state 45 ns, 1 wait state 55 ns, 2 wait states 70 ns, 2 wait states	45 ns devices
14.7456	29.4912	12 ns, 0 wait states 15 ns, 0 wait states 45 ns, 0 wait states 55 ns, 0 wait states 70 ns, 1 wait state	12 ns, 1 wait state 15 ns, 1 wait state 45 ns, 1 wait state 55 ns, 1 wait state 70 ns, 2 wait states	55 ns devices

**Table 31-10. Some Recommended Clock/Memory Configurations**

Input Frequency (MHz)	Internal Frequency (MHz)	Recommended Memory Timing		Optimal Use
		8-bit Devices	16-bit Devices (1 wait state min.)	
11.0592	22.1184	12 ns, 0 wait states	12 ns, 1 wait state	70 ns devices
		15 ns, 0 wait states	15 ns, 1 wait state	
		45 ns, 0 wait states	45 ns, 1 wait state	
		55 ns, 0 wait states	55 ns, 1 wait state	
		70 ns, 0 wait states	70 ns, 1 wait state	

The Rabbit 5000 is rated for a minimum clock period of 10 ns for both commercial and industrial specifications. The commercial rating calls for a  $\pm 5\%$  voltage variation from 3.3 V, and a temperature range from -40 to + 70°C. The industrial ratings stretch the voltage variation to  $\pm 10\%$  over a temperature range from -40 to + 85°C. This corresponds to maximum clock frequencies of about 100 MHz (commercial or industrial). If the clock doubler or spectrum spreader is used, these maximum ratings must be reduced as shown in Table 31-11.

**Table 31-11. Preliminary Maximum Clock Speeds**  
*( $V_{DD} \pm 10\%$ , Temp.  $-40^{\circ}\text{C}$  to  $+85^{\circ}\text{C}$ )*

Conditions	Industrial Ratings		Duty Cycle Requirements (ns)
	Minimum Period (ns)	Maximum Frequency (MHz)	
No Doubler or Spreader	17	58.8	
Spreader Only Normal	20	50.0	
Spreader Only Strong	21	47.6	
Doubler Only (8 ns delay)	19	52.6	1 > (clock low - clock high) > 0
Doubler Only (internal 50% clock)	20	50	1 > (clock low - clock high) > -1
Spreader Normal with Doubler (8 ns delay)	21	47.6	4 > (clock low - clock high) > 2
Spreader Normal with Doubler (8 ns delay), Internal 50% Clock	24	41.6	1 > (clock low - clock high) > -1
Spreader Only Strong	21.5	46.5	
Spreader Strong with Doubler (8 ns delay)	23	43.5	8 > (clock low - clock high) > 6

When the doubler is used, the duty cycle of the clock becomes a critical parameter. The duty cycle should be measured at the separate clock output pin (pin 2). The minimum period must be increased by any amount that the clock high time is greater or less than specified in the duty-cycle requirement.

For example, consider a design where the spreader and doubler are enabled, with 8 ns nominal delay in the doubler. The high and low clock are equal to within 1 ns. This violates the duty cycle requirement by 3 ns since (clock low - clock high) can be as small as -1 ns, but the requirement is that it not be less than 2 ns. Thus, 3 ns must be added to the minimum period of 21 ns, giving a minimum period of 24 ns and a maximum frequency of 41.6 MHz (commercial).

Since the built-in high-speed oscillator buffer generates a clock that is very close to having a 50% duty cycle, to obtain the highest clock speeds using the clock doubler you must use an external oscillator buffer that will allow for duty-cycle adjustment by changing the resistance of the power and ground connections as shown below.

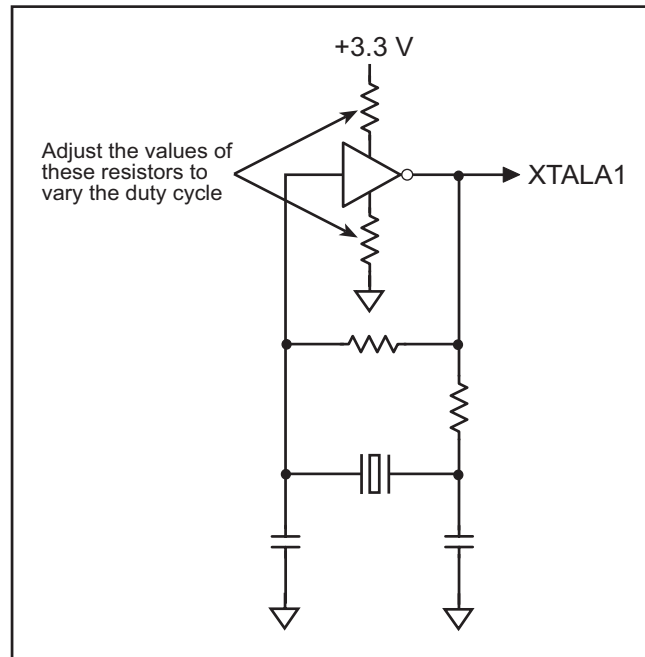
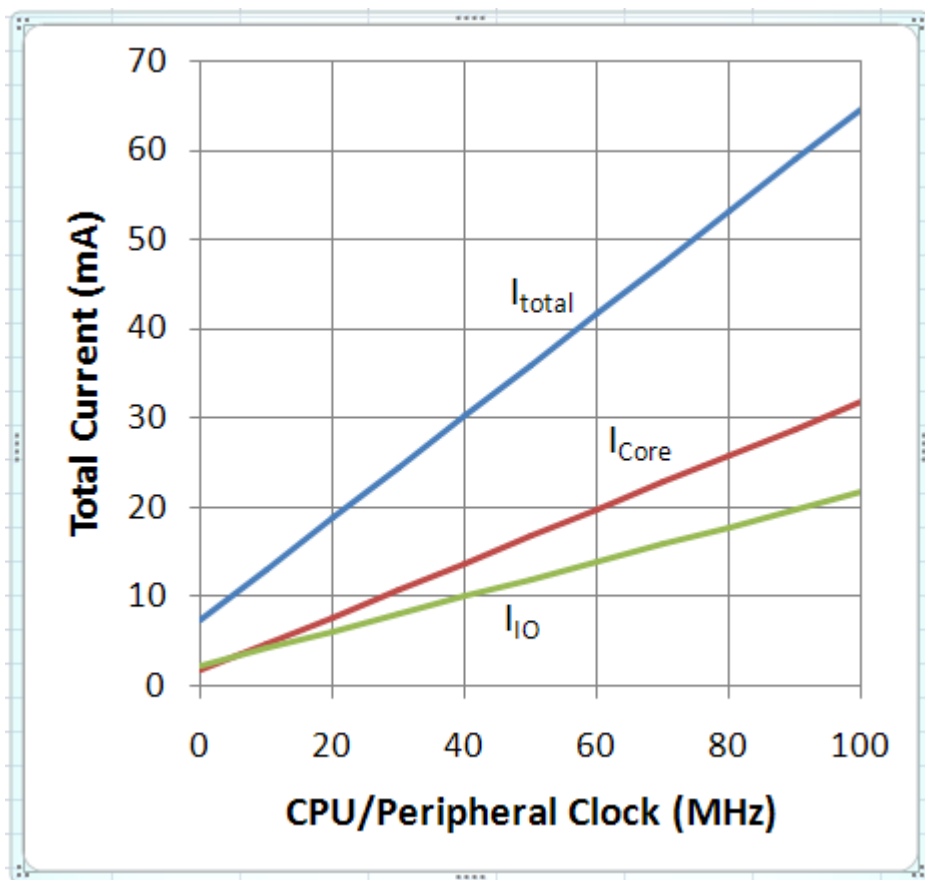

**Figure 31-4. External Oscillator Buffer**

## 31.5 Power and Current Consumption

Various mechanisms contribute to the current consumption of the Rabbit 5000 processor while it is operating, including current that is proportional to the voltage alone (leakage current) and dependent on both voltage and frequency (switching and crossover current). To reduce current consumption, the clock can be divided down in one of the sleep modes; see Table 29-1 for more details.

Figure 31-5 shows a typical current draw as a function of the main clock frequency while Wi-Fi is disabled. The values shown do not include any current consumed by external oscillators or memory. It is assumed that approximately 30 pF is connected to each address line.



**Figure 31-5. Typical Current Draw as a Function of the Main Clock Frequency (Wi-Fi disabled)**

When the 802.11 Wi-Fi peripheral is enabled, the current draw will increase by as much as 210mA, depending on activity.

### 31.5.1 Sleepy Mode Current Consumption

The Rabbit 5000 supports designs with very low power consumption by using features such as the ultra-sleepy modes and self-timed chip selects. At the low frequencies possible in the ultra-sleepy modes (as low as 2 kHz), the external memory devices become significant factors in the current consumption unless one of the short or self-timed chip selects are used. The I/O current use will vary with pin activity.

**Table 31-12. Typical Sleepy Mode Current Consumption  
(-40°C to +85°C)**

Pin	Voltage	Current
$I_{\text{CORE}}$	1.8 V	2 mA
$I_{\text{IO}}$	3.3 V	5 mA

### 31.5.2 Battery-Backed Clock Current Consumption

For the battery-backed features of the Rabbit 5000 to perform while the processor is powered down, both the VBAT and VBATIO pins need to be supplied properly. The VBAT pin powers the internal real-time clock and the battery-backed SRAM, while VBATIO powers the /RESET, /CS1, CLK32K, and RESOUT pins.

Note that the VBATIO pin can be powered at 1.8 V during powerdown even if the processor is running at 3.3 V normally. A circuit to switch between a 1.8–2.0 V battery and the main power can use the RESOUT pin to switch the power source for the VBATIO pin. R is a current-limiting resistor that should be adjusted for the battery voltage; a good value to use for a 3.0 V battery is 150 k $\Omega$ .

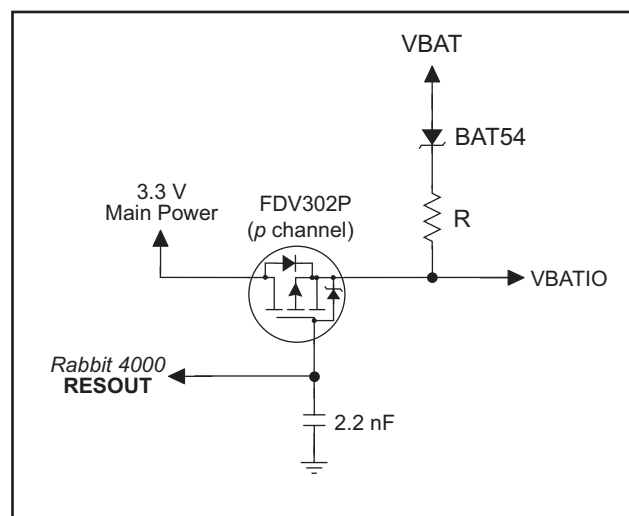

**Figure 31-6. Switching Circuit for VBATIO Pin**

Table 31-13 shows the typical current consumption for these pins while the remainder of the Rabbit 5000 is powered down.

**Table 31-13. Typical Battery-Backed Current Consumption (-40°C to +85°C)**

Pin	Voltage	Current
VBAT	1.8 V	290 nA
VBATIO	1.8 V	200 nA



# 32. PACKAGE SPECIFICATIONS AND PINOUT

## 32.1 Ball Grid Array Packages

### 32.1.1 Pinout 17 × 17 Ethernet Option

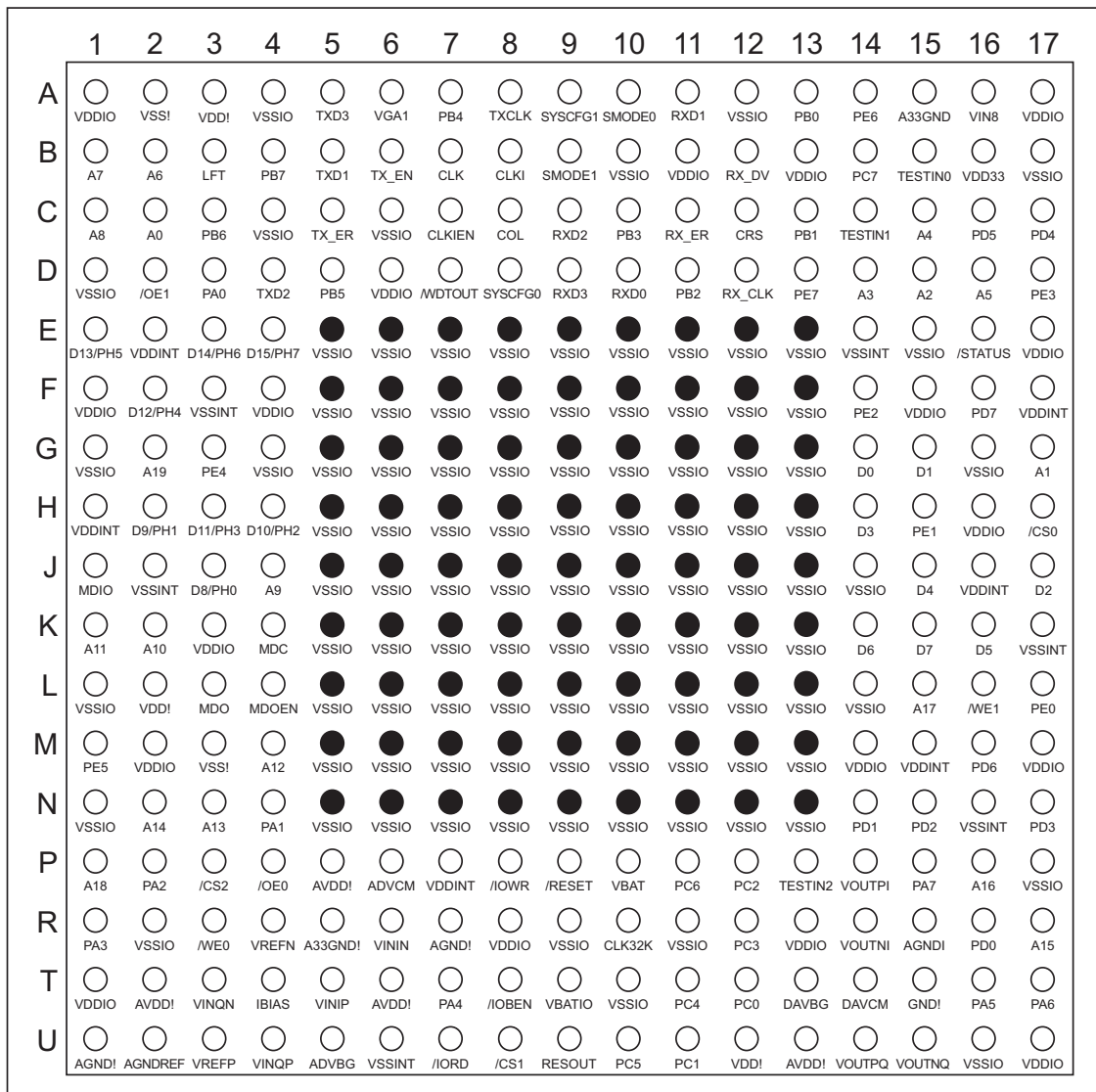

Figure 32-1. Ethernet Option Pinout Looking Through the Top of Package

### 32.1.2 Pinout 17 x 17 Wi-Fi Option

	1	2	3	4	5	6	7	8	9	10	11	12	13	14	15	16	17	
A	○	○	○	○	○	○	○	○	○	○	○	○	○	○	○	○	○	○
	VDDIO	VSSI	VDDI	VSSIO	VGA4	VGA1	PB4	LOCK	SYSCFG1	SMODE0	ANT_SELB	VSSIO	PB0	PE6	A33GND	VIN8	VDDIO	
B	○	○	○	○	○	○	○	○	○	○	○	○	○	○	○	○	○	○
	A7	A6	LFT	PB7	VGA2	TX_ON	CLK	CLKI	SMODE1	VSSIO	VDDIO	RX_ON	VDDIO	PC7	TESTIN0	VDD33	VSSIO	
C	○	○	○	○	○	○	○	○	○	○	○	○	○	○	○	○	○	○
	A8	A0	PB6	VSSIO	VGA0	VSSIO	CLKIEN	RXHP	LNA0	PB3	PA2G_ON	ACT_LED	PB1	TESTIN1	A4	PD5	PD4	
D	○	○	○	○	○	○	○	○	○	○	○	○	○	○	○	○	○	○
	VSSIO	/OE1	PA0	VGA3	PB5	VDDIO	WDTOUT	SYSCFG0	LNA1	ANT_SEL	PB2	PA5G_ON	PE7	A3	A2	A5	PE3	
E	○	○	○	○	●	●	●	●	●	●	●	●	●	○	○	○	○	○
	D13/PH5	VDDINT	D14/PH6	D15/PH7	VSSIO	VSSIO	VSSIO	VSSIO	VSSIO	VSSIO	VSSIO	VSSIO	VSSIO	VSSINT	VSSIO	/STATUS	VDDIO	
F	○	○	○	○	●	●	●	●	●	●	●	●	●	○	○	○	○	○
	VDDIO	D12/PH4	VSSINT	VDDIO	VSSIO	VSSIO	VSSIO	VSSIO	VSSIO	VSSIO	VSSIO	VSSIO	VSSIO	PE2	VDDIO	PD7	VDDINT	
G	○	○	○	○	●	●	●	●	●	●	●	●	●	○	○	○	○	○
	VSSIO	A19	PE4	VSSIO	VSSIO	VSSIO	VSSIO	VSSIO	VSSIO	VSSIO	VSSIO	VSSIO	VSSIO	D0	D1	VSSIO	A1	
H	○	○	○	○	●	●	●	●	●	●	●	●	●	○	○	○	○	○
	VDDINT	D9/PH1	D11/PH3	D10/PH2	VSSIO	VSSIO	VSSIO	VSSIO	VSSIO	VSSIO	VSSIO	VSSIO	VSSIO	D3	PE1	VDDIO	/CS0	
J	○	○	○	○	●	●	●	●	●	●	●	●	●	○	○	○	○	○
	CLK_IN	VSSINT	D8/PH0	A9	VSSIO	VSSIO	VSSIO	VSSIO	VSSIO	VSSIO	VSSIO	VSSIO	VSSIO	VSSIO	D4	VDDINT	D2	
K	○	○	○	○	●	●	●	●	●	●	●	●	●	○	○	○	○	○
	A11	A10	VDDIO	SCLK	VSSIO	VSSIO	VSSIO	VSSIO	VSSIO	VSSIO	VSSIO	VSSIO	VSSIO	D6	D7	D5	VSSINT	
L	○	○	○	○	●	●	●	●	●	●	●	●	●	○	○	○	○	○
	VSSIO	VDDI	SDATA	SENB	VSSIO	VSSIO	VSSIO	VSSIO	VSSIO	VSSIO	VSSIO	VSSIO	VSSIO	VSSIO	A17	/WE1	PE0	
M	○	○	○	○	●	●	●	●	●	●	●	●	●	○	○	○	○	○
	PE5	VDDIO	VSSI	A12	VSSIO	VSSIO	VSSIO	VSSIO	VSSIO	VSSIO	VSSIO	VSSIO	VSSIO	VDDIO	VDDINT	PD6	VDDIO	
N	○	○	○	○	●	●	●	●	●	●	●	●	●	○	○	○	○	○
	VSSIO	A14	A13	PA1	VSSIO	VSSIO	VSSIO	VSSIO	VSSIO	VSSIO	VSSIO	VSSIO	VSSIO	PD1	PD2	VSSINT	PD3	
P	○	○	○	○	○	○	○	○	○	○	○	○	○	○	○	○	○	○
	A18	PA2	/CS2	/OE0	AVDDI	ADVCM	VDDINT	/IOWR	/RESET	VBAT	PC6	PC2	TESTIN2	VOUTPI	PA7	A16	VSSIO	
R	○	○	○	○	○	○	○	○	○	○	○	○	○	○	○	○	○	○
	PA3	VSSIO	/WE0	VREFN	A33GNDI	VININ	AGNDI	VDDIO	VSSIO	CLK32K	VSSIO	PC3	VDDIO	VOUTNI	AGNDI	PD0	A15	
T	○	○	○	○	○	○	○	○	○	○	○	○	○	○	○	○	○	○
	VDDIO	AVDDI	VINQN	IBIAS	VINIP	AVDDI	PA4	/IOBEN	VBATIO	VSSIO	PC4	PC0	DAVBG	DAVCM	GNDI	PA5	PA6	
U	○	○	○	○	○	○	○	○	○	○	○	○	○	○	○	○	○	○
	AGNDI	AGNDREF	VREFF	VINQP	ADVBG	VSSINT	/IORD	/CS1	RESOUT	PC5	PC1	VDDI	AVDDI	VOUTPQ	VOUTNQ	VSSIO	VDDIO	

Figure 32-2. Wi-Fi Option Pinout Looking Through the Top of Package

### 32.1.3 Mechanical Dimensions and Land Pattern

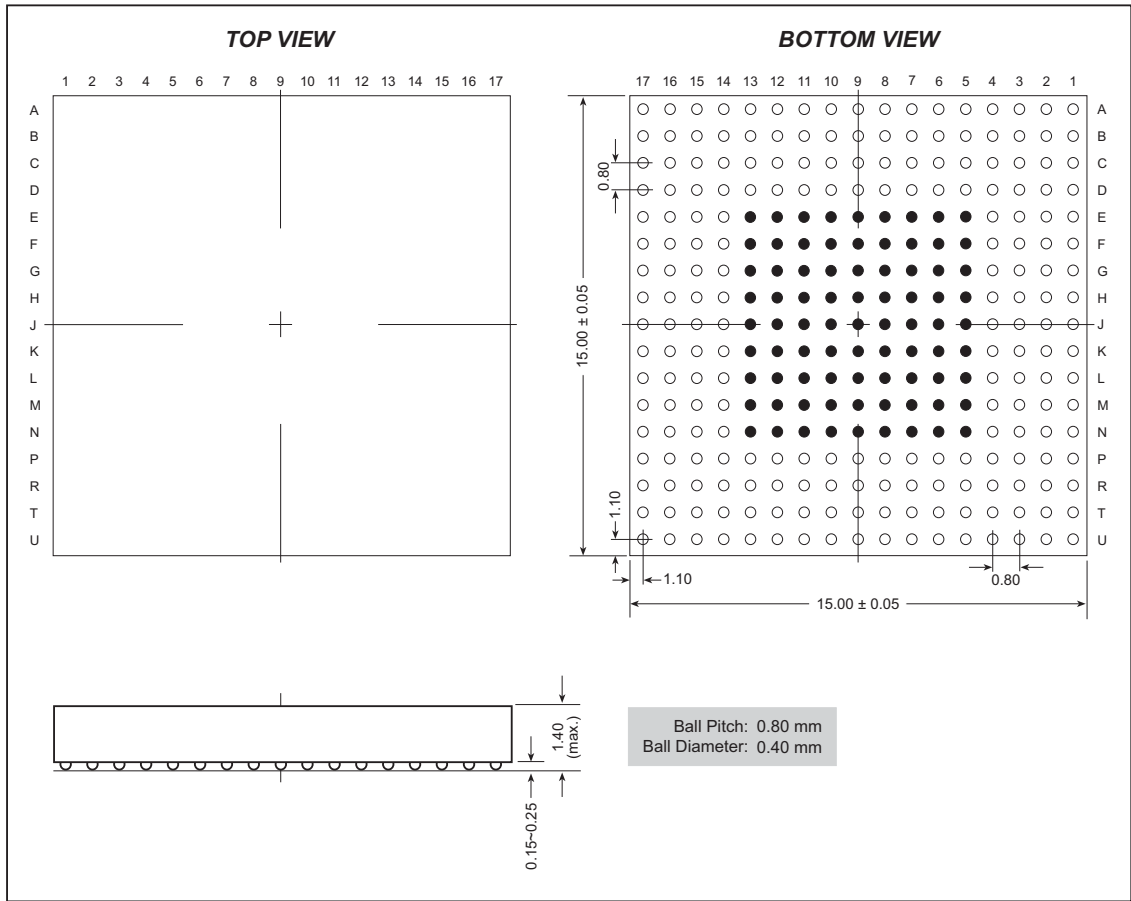

**Figure 32-3. BGA Package Outline**

**Table 32-1. Ball and Land Size Dimensions**

Nominal Ball Diameter (mm)	Tolerance Variation (mm)	Ball Pitch (mm)	Nominal Land Diameter (mm)	Land Variation (mm)
0.40	0.45–0.35	0.80	0.35	0.35–0.30

The design considerations in Table 32-2 are based on 5 mil design rules and assume a single conductor between solder lands.

**Table 32-2. Design Considerations  
(all dimensions in mm)**

Key	Feature	Recommendation
A	Solder Land Diameter	0.356 (0.014)
B	NSMD Defined Land Diameter	0.406 (0.016)
C	Land to Mask Clearance (min.)	0.076 (0.003)
D	Conductor Width (max.)	0.127 (0.005)
E	Conductor Spacing (typ.)	0.127 (0.005)
F	Via Capture Pad (max.)	0.406 (0.016)
G	Via Drill Size (max.)	0.203 (0.008)

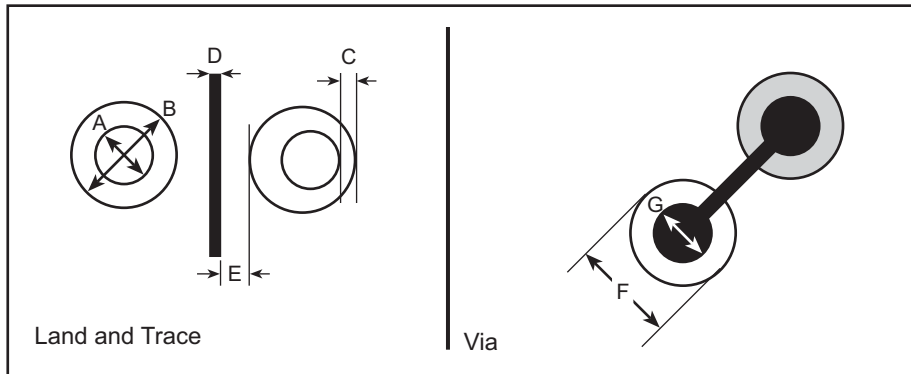

## 32.2 Rabbit Pin Descriptions

Table 32-3 lists all the pins on the Rabbit 5000 along with the data direction of the pin, its function, and the pin number on the die.

**Table 32-3. Rabbit 5000 Pin Descriptions**

Pin Group	Pin Name	Direction	Function	LFBGA Ball
Hardware	CLK	Output	Internal Clock Output	B7
	CLK32K	Input	32 kHz Clock In	R10
	/RESET	Input	Master Reset	P9
	RESOUT	Output	Reset Output	U9
	CLKI	Input	Main Clock In	B8
	CLKIEN	Output	Main Clock Enable	C7
CPU Buses	A[19:0]	Output	Address Bus	various
	D[9:0]	Bidirectional	Data Bus	various
Status & Control	/WDTOUT	Output	Watchdog Timer Timeout	D7
	STATUS	Output	Instruction Fetch First Byte	E16
	SMODE1 SMODE0	Input	Bootstrap Mode & Tamper Detect	B9, A10
Chip Selects	/CS0	Output	Memory Chip Select 0	H17
	/CS1	Output	Memory Chip Select 1	U8
	/CS2	Output	Memory Chip Select 2	P3
Output Enables	/OE0	Output	Memory Output Enable 0	P4
	/OE1	Output	Memory Output Enable 1	D2
Write Enables	/WE0	Output	Memory Write Enable	R3
	/WE1	Output	Memory Write Enable	L16
I/O Control	/IOBEN	Output	I/O Buffer Enable	T8
	/IORD	Output	I/O Read Enable	U7
	/IOWR	Output	I/O Write Enable	P8
I/O Ports	PA[7:0]	Input/Output	I/O Parallel Port A	various
	PB[7:0]	Input/Output	I/O Parallel Port B	various
	PC[7:0]	Input/Output	I/O Parallel Port C	various
	PD[7:0]	Input/Output	I/O Parallel Port D	various
	PE[7:0]	Input/Output	I/O Parallel Port E	various
	PH[7:0]	Input/Output	I/O Parallel Port H	various

**Table 32-3. Rabbit 5000 Pin Descriptions (continued)**

Pin Group	Pin Name	Direction	Function	LFBGA Ball
Ethernet	MDC	Output	Media-Independent Interface (MII)	K4
	MDO			L3
	MDOEN			L4
	TXD0			A6
	TXD1			B5
	TXD2			D4
	TXD3			A5
	TX_EN			B6
	TX_ER			C5
	COL	Input		C8
CRS	C12			
RX_CLK	D12			
RX_DV	B12			
RX_ER	C11			
RXD0	D10			
RXD1	A11			
RXD2	C9			
RXD3	D9			
TX_CLK	A8			
MDIO	Bidirectional	J1		
Wi-Fi	ACT_LED	Output	Wi-Fi Interface	C12
	ANT_SEL			D10
	ANT_SELB			A11
	LNA0			C9
	LNA1			D9
	PA2G_ON			C11
	PA5G_ON			D12
	RX_ON			B17
	RXHP			G8
	SCLK			K4
	SDATA			K3
	SENB			L4
	TX_ON			B6
	VGA0			C5
	VGA1			A6
	VGA2			B5
	VGA3			D4
	VGA4			A5
	CLK_IN	Input		J1
LOCK	A8			

**Table 32-3. Rabbit 5000 Pin Descriptions (continued)**

Pin Group	Pin Name	Direction	Function	LFBGA Ball
Analog	VININ VINIP VINQN VINQP	Input	Analog Component 0 — Fast A/D Converter	R6 T5 T3 U4
	PD4	Clock		C17
	VOUTNI VOUTPI VOUTNQ VOUTPQ	Output	Analog Component 1 — Fast D/A Converter	R14 P14 U15 U14
	PD5	Clock		C16
	VIN8	Input	Analog Component 2 — Slow A/D Converter	A16
	PD6	Clock		M16





# APPENDIX A. PARALLEL PORT PINS WITH ALTERNATE FUNCTIONS

## A.1 Alternate Parallel Port Pin Outputs

*Table A-1. Alternate Parallel Port A and B Pin Outputs*

Pin	Alternate Output Options		
	Serial Clock	External I/O Bus	Slave Port
PA[7:0]	—	ID[7:0]	SD[7:0]
PB7	—	IA5	/SLVATTN
PB6	—	IA4	/SCS
PB5	—	IA3	SA1
PB4	—	IA2	SA0
PB3	—	IA1	/SRD
PB2	—	IA0	/SWR
PB1	SCLKA	IA7	—
PB0	SCLKB	IA6	—

**Table A-2. Alternate Parallel Port C, D, E, and H Pin Outputs**

Pin	Alternate Output Option				
	0	1	2	3	16-bit Data
PC7	TXA	I7	PWM3	SCLKC	—
PC6	TXA	I6	PWM2	TXE	—
PC5	TXB	I5	PWM1	RCLKE	—
PC4	TXB	I4	PWM0	TCLKE	—
PC3	TXC	I3	TIMER C3	SCLKD	—
PC2	TXC	I2	TIMER C2	TXF	—
PC1	TXD	I1	TIMER C1	RCLKF	—
PC0	TXD	I0	TIMER C0	TCLKF	—
PD7	IA7	I7	PWM3	SCLKC	—
PD6	TXA	I6	PWM2	TXE	—
PD5	IA6	I5	PWM1	RCLKE	—
PD4	TXB	I4	PWM0	TCLKE	—
PD3	IA7	I3	TIMER C3	SCLKD	—
PD2	SCLKC	I2	TIMER C2	TXF	—
PD1	IA6	I1	TIMER C1	RCLKF	—
PD0	SCLKD	I0	TIMER C0	TCLKF	—
PE7	I7	—	PWM3	SCLKC	—
PE6	I6	—	PWM2	TXE	—
PE5	I5	—	PWM1	RCLKE	—
PE4	I4	/A0	PWM0	TCLKE	—
PE3	I3	A23	TIMER C3	SCLKD	—
PE2	I2	A22	TIMER C2	TXF	—
PE1	I1	A21	TIMER C1	RCLKF	—
PE0	I0	A20	TIMER C0	TCLKF	—
PH7	—	I7	PWM3	SCLKC	D15
PH6	—	I6	PWM2	TXE	D14
PH5	—	I5	PWM1	RCLKE	D13
PH4	—	I4	PWM0	TCLKE	D12
PH3	—	I3	TIMER C3	SCLKD	D11
PH2	—	I2	TIMER C2	TXF	D10
PH1	—	I1	TIMER C1	RCLKF	D9
PH0	—	I0	TIMER C0	TCLKF	D8

## A.2 Alternate Parallel Port Pin Inputs

*Table A-3. Alternate Parallel Port Pin Inputs*

Pin	Input Capture	I/O Handshake	DMA	External Interrupt	Network	Quadrature Decoder	Slave Port	Serial Ports A–D	Serial Ports E–F
PA[7:0]	—	—	—	—	—		SD[7:0]	—	—
PB7	—	—	—	—	—	—	/SLVATTN	—	—
PB6	—	—	—	—	—	—	/SCS	—	—
PB5	—	—	—	—	—	—	SA1	—	—
PB4	—	—	—	—	—	—	SA0	—	—
PB3	—	—	—	—	—	—	/SRD	—	—
PB2	—	—	—	—	—	—	/SWR	—	—
PB1	—	—	—	—	—	—	—	SCLKA	—
PB0	—	—	—	—	—	—	—	SCLKB	—
PC7	×	—	—	—	—	—	—	RXA	RXE
PC6	—	—	—	—	—	—	—	—	—
PC5	×	—	—	—	—	—	—	RXB	RCLKF
PC4	—	—	—	—	—	—	—	—	TCLKF
PC3	×	—	—	—	—	—	—	RXC	RXF
PC2	—	—	—	—	—	—	—	—	—
PC1	×	—	—	—	—	—	—	RXD	RCLKF
PC0	—	—	—	—	—	—	—	—	TCLKF
PD7	×	—	—	—	—	—	—	RXA	RXE
PD6	—	—	—	—	—	—	—	—	—
PD5	×	—	—	—	—	—	—	RXB	RCLKF
PD4	—	—	—	—	—	—	—	—	TCLKF
PD3	×	—	DREQ1	—	—	QRD2A	—	RXC	RXF
PD2	—	—	DREQ0	—	—	QRD2B	—	SCLKC	—
PD1	×	—	—	INT1	—	QRD1A	—	RXD	RCLKF
PD0	—	—	—	INT0	—	QRD1B	—	SCLKD	TCLKF
PE7	×	×	DREQ1	—	—	—	/SCS	RXA	RXE
PE6	—	×	DREQ0	—	ECLK	—	—	—	—

**Table A-3. Alternate Parallel Port Pin Inputs (continued)**

Pin	Input Capture	I/O Handshake	DMA	External Interrupt	Network	Quadrature Decoder	Slave Port	Serial Ports A-D	Serial Ports E-F
PE5	×	×	—	INT1	—	—	—	RXB	RCLKE
PE4	—	×	—	INT0	—	—	—	—	TCLKE
PE3	×	×	DREQ1	—	—	QRD2A	—	RXC	RXF
PE2	—	×	DREQ0	—	—	QRD2B	—	SCLKC	—
PE1	×	×	—	INT1	—	QRD1A	—	RXD	RCLKF
PE0	—	×	—	INT0	—	QRD1B	—	SCLKD	TCLKF

# INDEX

## Numerics

32 kHz clock ..... 18  
oscillator circuit ..... 18

## A

analog components ..... 203  
block diagram ..... 206  
clocks ..... 207  
dependencies ..... 207  
fast A/D converter  
Analog Component 0  
Control Register ..... 212  
Analog Component 0 LSB  
Registers ..... 211  
Analog Component MSB  
Registers ..... 211  
fast D/A converter  
Analog Component 1  
Control Register ..... 213  
Analog Component 1 LSB  
Registers ..... 212  
Analog Component 1 MSB  
Registers ..... 213  
operation ..... 208  
registers ..... 207  
sample circuits ..... 209  
slow A/D converter  
Analog Component 2 Control Register ..... 215  
Analog Component 2 LSB  
Register ..... 214  
Analog Component 2 MSB  
Register ..... 214  
specifications ..... 204  
fast A/D converter ..... 204  
fast D/A converter ..... 204  
slow A/D converter ..... 205

## B

block diagram  
analog components ..... 206  
bootstrap ..... 26  
breakpoints ..... 320  
clocks ..... 10  
DMA channels ..... 220  
external I/O control ..... 306  
external interrupts ..... 73  
input capture channels .... 276  
memory management ..... 48  
Network Port B ..... 247  
Network Port C ..... 270  
Parallel Port A ..... 77  
Parallel Port B ..... 82  
Parallel Port C ..... 86  
Parallel Port D ..... 95  
Parallel Port E ..... 113  
Parallel Port H ..... 132  
PWM ..... 297  
Quadrature Decoder ..... 289  
Rabbit 5000 ..... 4  
reset ..... 26  
Serial Ports A – D ..... 161  
Serial Ports E – F ..... 176  
slave port ..... 192  
system management ..... 34  
Timer A ..... 139  
Timer B ..... 145  
Timer C ..... 152  
bootstrap ..... 25  
block diagram ..... 26  
dependencies ..... 27  
memory fetch ..... 29  
onchip-encryption SRAM . 30  
register descriptions ..... 32  
registers ..... 26

breakpoints ..... 319  
block diagram ..... 320  
dependencies ..... 322  
interrupts ..... 322  
example ISR ..... 323  
operation ..... 322  
overview ..... 319  
register descriptions ..... 324  
registers ..... 321

## C

clock modes ..... 12  
clocks ..... 9  
32 kHz clock ..... 18  
oscillator circuit ..... 18  
power consumption ..... 18  
block diagram ..... 10  
clock doubler ..... 15, 16  
clock modes ..... 12  
clock speeds ..... 369  
doubling/dividing ..... 9  
EMI mitigation ..... 9  
Ethernet clock ..... 9  
maximum clock speed ..... 17  
operation ..... 12  
overview ..... 9  
power consumption ..... 17  
register descriptions ..... 20  
registers ..... 10  
sleepy clock modes ..... 19  
spectrum spreader ..... 9, 365  
comparison with other Rabbit  
microprocessors ..... 6

## D

- design considerations
  - BGA package .....378
- dimensions
  - BGA package .....377
- DMA channels .....217
  - block diagram .....220
  - buffer descriptor .....223
  - buffer descriptor modes ...226
  - channel priorities .....226
  - clocks .....222
  - control .....218
  - dependencies .....222
  - external requests .....217
  - interrupts .....219, 222, 224
    - example ISR .....224
  - memory addresses .....218
  - operation .....223
  - overview .....217
  - priorities .....224
  - register descriptions .....231
  - registers .....221
  - setup .....223
  - timed requests .....218
  - transfer priorities .....224
  - transfer priority .....224
  - transfer rates .....225
  - transfers .....219
  - use with peripherals .....230
    - Ethernet .....230
    - HDLC serial ports .....230
    - PWM and Timer C .....230
- DMA control .....217

## E

- ESD
  - ESD sensitivity .....2
- external I/O bus .....303
  - operation .....308
    - handshake .....308
    - strokes .....308
- external I/O control .....303
  - block diagram .....306
  - clocks .....307
  - dependencies .....307
  - external I/O bus .....303
  - handshake .....305
  - operation .....308
    - external I/O bus .....308
    - handshake .....308
    - strokes .....308
  - overview .....303
  - register descriptions .....309
  - registers .....306
  - strokes .....304

## H

- hardware debugging.
  - See* breakpoints

## I

- input capture channels .....275
  - block diagram .....276
  - clocks .....278
  - dependencies .....278
  - interrupts .....278, 279
    - example ISR .....279
  - load parallel port output
    - registers .....276
  - measure pulse widths .....275
  - modes .....275
    - input-capture mode .....275
    - input-count mode .....275
  - operation .....279
    - input-capture mode .....280
    - input-count mode .....280
  - overview .....275
  - register descriptions .....281
  - registers .....277
  - start and stop events .....275
- interrupt priorities .....72
- interrupts .....69
  - breakpoints .....322
    - example ISR .....323
  - DMA channels 219, 222, 224
    - example ISR .....224
  - external interrupt vector table .....71
  - external interrupts .....73, 74
    - block diagram .....73
    - clocks .....74
    - dependencies .....74
    - example ISR .....74
    - interrupt vectors .....74
    - operation .....74
    - register descriptions .....75
    - registers .....74
  - input capture channels .....278, 279
    - example ISR .....279
  - internal interrupt vector table .....70
  - interrupt priorities .....72
  - memory management .....50
  - Network Port B .....251, 253
  - Network Port C .....274
  - operation .....70
  - Parallel Port D .....97
  - Parallel Port E .....115

- Parallel Port H .....133
- priority levels .....69
- PWM .....295, 298, 299
  - example ISR .....299
- Quadrature Decoder 288, 290
  - example ISR .....291
- Serial Ports A – D .....164
- Serial Ports E – F .....179
- slave port .....191, 193, 196
  - example ISR .....196
- system management 33, 36, 37
- System/User mode ..342, 348
- Timer A .....138, 141
  - example ISR .....141
- Timer B .....146, 147
  - example ISR .....147
- Timer C .....154, 155
  - example ISR .....155

## L

- land pattern
  - BGA package .....377
- low-power operation .....327
  - clock rates .....329
    - clock modes .....329
  - handling unused pins .....329
  - operation .....329
  - overview .....327
  - register descriptions .....336
  - registers .....328
  - self-timed chip selects .....335
  - short chip selects .....330

## M

- memory
  - read and write cycles (no wait states) .....362
- memory management .....45
  - block diagram .....48
  - clocks .....50
  - dependencies .....50
  - interrupts .....50
  - logical memory space .....46
  - mapping physical memory
    - space .....46
  - MMU operation .....52
  - operation .....51
    - 16-bit and page modes ...54
    - instruction and data space .....56
    - memory protection .....56
  - MMU .....51
  - read and write transactions .....54
  - stack protection .....57

- overview ..... 45
- physical and logical memory mapping ..... 47
- register descriptions ..... 58
- registers ..... 49, 50, 51
- memory protection ..... 56

## N

Network Port B

- block diagram ..... 247
- clock ..... 245
- clocks ..... 250
- dependencies ..... 250
- DMA transfers ..... 246
- interrupts ..... 251, 253
- operation ..... 251
  - multicast addressing .... 254
  - receive ..... 252
  - transmit ..... 252
- overview ..... 245
- receiver ..... 246
- register descriptions ..... 255
- registers ..... 248
- setup ..... 252
- transmitter ..... 245

Network Port C

- block diagram ..... 270
- clocks ..... 274
- dependencies ..... 273
- interrupts ..... 274
- operation ..... 274
- overview ..... 269
- registers ..... 271

## O

opcodes

- System/User mode ..... 346

## P

Parallel Port A ..... 77

- alternate output functions .. 77
- block diagram ..... 77
- clocks ..... 78
- external I/O data bus ..... 77
- operation ..... 78
- overview ..... 77
- register description ..... 83
- register descriptions ..... 79
- registers ..... 77
- slave port data bus ..... 77

Parallel Port B ..... 81

- alternate output functions .. 81
- block diagram ..... 82
- clocks ..... 82
- dependencies ..... 82
- external I/O bus ..... 81
- operation ..... 83
- overview ..... 81
- register descriptions ..... 83
- registers ..... 82
- slave port enabled ..... 81
- SPCR setup ..... 81

Parallel Port C ..... 85

- alternate input functions ... 85
- alternate output functions .. 85
- block diagram ..... 86
- clocks ..... 87
- dependencies ..... 87
- operation ..... 87
- overview ..... 85
- PCDR setup ..... 85
  - default ..... 86
- register descriptions ..... 88
- registers ..... 86

Parallel Port D ..... 93

- alternate input functions ... 94
- alternate output functions .. 93
- block diagram ..... 95
- clocks ..... 97
- dependencies ..... 97
- interrupts ..... 97
- operation ..... 98
- overview ..... 93
- PDDR setup ..... 93
- register descriptions ..... 99
- registers ..... 96

Parallel Port E ..... 111

- alternate input functions .. 112
- alternate output functions 111
- block diagram ..... 113
- clocks ..... 114
- dependencies ..... 114
- interrupts ..... 115
- operation ..... 115
- overview ..... 111
- PEDR setup ..... 111
- register descriptions ..... 116
- registers ..... 114

Parallel Port H ..... 131

- alternate output functions 131
- block diagram ..... 132
- clocks ..... 133
- dependencies ..... 133
- interrupts ..... 133

operation ..... 133

overview ..... 131

PHDR setup ..... 131

register descriptions ..... 134

registers ..... 132

peripherals

- system management ..... 33

pin descriptions ..... 379

- alternate pin functions
  - Parallel Port A and B outputs ..... 383
  - Parallel Port C, D, and E outputs ..... 384
  - parallel port inputs ..... 385

pin functions ..... 379

- alternate pin functions
  - Parallel Port A and B outputs ..... 383
  - Parallel Port C, D, and E outputs ..... 384
  - parallel port inputs ..... 385

pinout ..... 379

- BGA package ..... 375, 376

power consumption ..... 17

pulse width modulator.

*See PWM*

PWM ..... 295

- block diagram ..... 297
- channels ..... 298
- clocks ..... 298
- dependencies ..... 298
- DMA channels ..... 296
- interrupts ..... 295, 298, 299
  - example ISR ..... 299
- operation ..... 299
- outputs ..... 295, 296
- overview ..... 295
- register descriptions ..... 300
- registers ..... 297
- spreading function ..... 296

## Q

Quadrature Decoder ..... 287

- block diagram ..... 289
- clocks ..... 288, 290
- counter operation ..... 287
- dependencies ..... 290
- inputs ..... 287
- interrupts ..... 288, 290, 291
  - example ISR ..... 291
- operation ..... 291
- overview ..... 287
- register descriptions ..... 292
- registers ..... 289

## R

Rabbit 2000 .....	6
Rabbit 3000 .....	6
Rabbit 5000 .....	1
block diagram .....	4
comparison with other Rabbit microprocessors .....	6
feature summary .....	1
features .....	2
10/100Base-T Ethernet ....	3
EMI mitigation .....	2
input-capture channels ....	2
instruction set .....	2
memory access .....	2
onchip-encryption RAM ..	3
parallel ports .....	2
protected operating systems .....	3
PWM outputs .....	3
Quadrature-Decoder channels .....	2
timers .....	2
specifications .....	5
Rabbit Semiconductor history .....	1
registers	
alphabetic listing	
A0CR .....	212
A0ILR .....	211
A0IMR .....	211
A0QLR .....	211
A0QMR .....	211
A1CR .....	213
A1ILR .....	212
A1IMR .....	213
A1QLR .....	212
A1QMR .....	213
A2CR .....	215
A2LR .....	214
A2MR .....	214
ACSxCR .....	63
AUER .....	353
BDCR .....	324
BxA0R .....	325
BxA1R .....	325
BxA2R .....	325
BxCR .....	324
BxM0R .....	326
BxM1R .....	326
BxM2R .....	326
DATASEG .....	59
DATASEGH .....	59
DATASEGL .....	59
DMALR .....	231

## registers

### alphabetic listing (continued)

DMCR .....	232
DMCSR .....	231
DMHR .....	231
DMR0CR ....	108, 125, 234
DMR1CR ....	109, 126, 235
DMTCR .....	233
DTRCR .....	236
DTRDHR .....	236
DTRDLR .....	236
DyBCR .....	232
DyBU0R .....	237
DyBU1R .....	238
DyCR .....	240
DyDA0R .....	243
DyDA1R .....	243
DyDA2R .....	243
DyIA0R .....	238
DyIA1R .....	238
DyIA2R .....	238
DyL0R .....	241
DyLA0R .....	244
DyLA1R .....	244
DyLA2R .....	244
DyLnR .....	241
DySA0R .....	242
DySA1R .....	242
DySA2R .....	242
DySCR .....	239
DyTBR .....	237
DyTMR .....	237
EDMR .....	355
ENPR .....	268
GCDR .....	22, 338
GCM0R .....	21
GCM1R .....	21
GCPU .....	42
GCSR	
20, 39, 144, 150, 158, 336	
GOCR .....	23, 42
GPSCR .....	337
GRAM .....	41
GREV .....	42
GROM .....	41
IBUER .....	352
IbxCR .....	311
ICCR .....	282
ICCSR .....	281
ICLxR .....	284
ICMxR .....	285
ICSxR ....	91, 105, 122, 284
ICTxR .....	283
ICUER .....	351
IHCR .....	128, 309
IHSR .....	129, 310
IHTR .....	129, 310

## registers

### alphabetic listing (continued)

IUER .....	353
IxCR .....	75, 107, 124
MACR .....	62, 136
MBxCR .....	60
MECR .....	61
MMIDR .....	58
MTCR .....	61
NBCF0R .....	261
NBCF1R .....	261
NBCF2R .....	262
NBCF3R .....	262
NBCR .....	257
NBCSR .....	256
NBCWR .....	263
NBDMR .....	260
NBDR .....	255
NBDRR .....	260
NBDTR .....	260
NBFLLR .....	264
NBFLMR .....	264
NBG0R .....	263
NBG1R .....	263
NBG2R .....	263
NBLDR .....	255
NBMCFR .....	264
NBMCR .....	266
NBMFxR .....	259
NBMPar .....	266
NBMRAR .....	266
NBMRLR .....	266
NBMRMR .....	267
NBMRR .....	264
NBMSR .....	267
NBMWLR .....	266
NBMWMR .....	266
NBPxR .....	259
NBRCR .....	258
NBRMR .....	263
NBSAxR .....	267
NBTCR .....	258
NBTESR .....	259
NBTPLR .....	257
NBTPMR .....	257
NBTSR .....	255
PADR .....	79
PAUER .....	350
PBDDR .....	83
PBDR .....	83
PBUER .....	350
PCADR .....	89, 314
PCALR .....	88, 313
PCDCR .....	89



registers

alphabetic listing (continued)

PCDDR .....	88
PCDR .....	88
PCFR .....	89, 314
PCUER .....	351
PDAHR .....	100, 316
PDALR .....	99, 315
PDB0R .....	101
PDB1R .....	101
PDB2R .....	102
PDB3R .....	102
PDB4R .....	102
PDB5R .....	102
PDB6R .....	103
PDB7R .....	103
PDCR .....	100
PDDCR .....	101
PDDDR .....	101
PDDR .....	99
PDFR .....	101, 316
PDUER .....	351
PEAHR .....	117, 318
PEALR .....	116, 317
PEB0R .....	118
PEB1R .....	118
PEB2R .....	119
PEB3R .....	119
PEB4R .....	119
PEB5R .....	119
PEB6R .....	120
PEB7R .....	120
PECR .....	117
PEDCR .....	118
PEDDR .....	118
PEDR .....	116
PEFR .....	118, 318
PEUER .....	351
PHAHR .....	135
PHALR .....	134
PHDCR .....	135
PHDDR .....	136
PHDR .....	134
PHFR .....	135
PHUER .....	350
PWBAR .....	301
PWBPR .....	301
PWLOR .....	300
PWL1R .....	300
PWLxR .....	301
PWMxR .....	301
PWUER .....	352
QDCR .....	106, 123, 293
QDCSR .....	292
QDCxHR .....	293

registers

alphabetic listing (continued)

QDCxR .....	293
QDUER .....	352
RAMSR .....	63
RTCCR .....	40
RTCxR .....	40
RTUER .....	350
SAUER .....	354
SBUER .....	354
SCUER .....	354
SDUER .....	354
SEGSIZ .....	60
SEUER .....	355
SFUER .....	355
SPCR .....	32, 79, 84, 127, 201, 312
SPDxR .....	200
SPSR .....	200
SPUER .....	350
STACKSEG .....	58
STACKSEGH .....	59
STACKSEGL .....	59
STKCR .....	67
STKHLR .....	68
STKLLR .....	67
SWDTR .....	41
SxAR .....	168, 185
SxCr .....	90, 121, 171, 188
SxCr .....	104
SxDHR .....	174, 190
SxDLR .....	173, 190
SxDR .....	168, 185
SxER (asynch mode) .....	172, 189
SxER (clocked serial mode) .....	173
SxER (HDLC mode) ... ..	190
SxLR .....	168, 185
SxSR (asynch mode) .....	169, 186
SxSR (clocked serial mode) .....	170
SxSR (HDLC mode) ... ..	187
TACR .....	143
TACSR .....	142
TAPR .....	142
TATxR .....	143
TAUER .....	353
TBCLR .....	150
TBCMR .....	149
TBCR .....	148
TBCSR .....	148
TBLxR .....	149

registers

alphabetic listing (continued)

TBMxR .....	149
TBSLxR .....	149
TBSMxR .....	149
TBUER .....	353
TCBAR .....	157
TCBPR .....	158
TCCR .....	156
TCCSR .....	156
TCDHR .....	156
TCDLR .....	156
TCRxHR .....	157
TCRxLR .....	157
TCSxHR .....	157
TCSxLR .....	157
TCUER .....	354
VRAM00–VRAM1F ....	43
WDTCR .....	40
WDTTR .....	41
WPCR .....	64
WPSxHR .....	67
WPSxLR .....	66
WPSxR .....	66
WPxR .....	65
analog components .....	207
bootstrap .....	26
breakpoints .....	321
Breakpoint x Address 0 .....	325
Register .....	325
Breakpoint x Address 1 .....	325
Register .....	325
Breakpoint x Address 2 .....	325
Register .....	325
Breakpoint x Control .....	324
Register .....	324
Breakpoint x Mask 0 .....	326
Register .....	326
Breakpoint x Mask 1 .....	326
Register .....	326
Breakpoint x Mask 2 .....	326
Register .....	326
Breakpoint/Debug Control .....	324
Register .....	324
clocks .....	10
Global Clock Double .....	22
Register .....	22
Global Clock Modulator 0 .....	21
Register .....	21
Global Clock Modulator 1 .....	21
Register .....	21
Global Control/Status .....	20
Register .....	20
Global Output Control .....	23
Register .....	23

registers (continued)

DMA channels .....221  
 DMA Master Auto-Load Register .....231  
 DMA Master Control Register .....232  
 DMA Master Control/Status Register .....231  
 DMA Master Halt Register .....231  
 DMA Master Request 0 Control Register ..... 108, 125, 234  
 DMA Master Request 1 Control Register ..... 109, 126, 235  
 DMA Master Timing Control Register .....233  
 DMA Timed Request Control Register .....236  
 DMA Timed Request Divider High Register .....236  
 DMA Timed Request Divider Low Register .....236  
 DMA y Buffer Complete Register .....232  
 DMA y Buffer Unused[15:8] Register .....238  
 DMA y Buffer Unused[7:0] Register .....237  
 DMA y Control Register .....240  
 DMA y Destination Addr[15:8] Register ..243  
 DMA y Destination Addr[23:16] Register 243  
 DMA y Destination Addr[7:0] Register ....243  
 DMA y Initial Addr[15:8] Register .....238  
 DMA y Initial Addr[23:16] Register .....238  
 DMA y Initial Addr[7:0] Register .....238  
 DMA y Length[15:8] Register .....241  
 DMA y Length[7:0] Register .....241  
 DMA y Link Addr[15:8] Register .....244  
 DMA y Link Addr[23:16] Register .....244  
 DMA y Link Addr[7:0] Register .....244

registers

DMA channels (continued)  
 DMA y Source Addr[15:8] Register .....242  
 DMA y Source Addr[23:16] Register .....242  
 DMA y Source Addr[7:0] Register .....242  
 DMA y Special Control Register .....239  
 DMA y Termination Byte Register .....237  
 DMA y Termination Mask Register .....237  
 external I/O control .....306  
 I/O Bank x Control Register .....311  
 I/O Handshake Control Register ..... 128, 309  
 I/O Handshake Select Register ..... 129, 310  
 I/O Handshake Timeout Register ..... 129, 310  
 Parallel Port C Alternate High Register .....314  
 Parallel Port C Alternate Low Register .....313  
 Parallel Port C Function Register .....314  
 Parallel Port D Alternate High Register .....316  
 Parallel Port D Alternate Low Register .....315  
 Parallel Port D Function Register .....316  
 Parallel Port E Alternate High Register .....318  
 Parallel Port E Alternate Low Register .....317  
 Parallel Port E Function Register .....318  
 Slave Port Control Register .....312  
 external interrupts ..... 74  
 Interrupt x Control Register .....75, 107, 124  
 input capture channels .....277  
 Input Capture Control Register .....282  
 Input Capture Control/Status Register .....281  
 Input Capture LSB x Register .....284  
 Input Capture MSB x Register .....285

registers

input capture channels (cont'd)  
 Input Capture Source x Register 91, 105, 122, 284  
 Input Capture Trigger x Register .....283  
 low-power operation .....328  
 Global Clock Double Register .....338  
 Global Control/Status Register .....336  
 Global Power Save Control Register .....337  
 memory management ..49, 51  
 Advanced Chip Select x Control Register .....63  
 Data Segment High Register .....59  
 Data Segment Low Register .....59  
 Data Segment Register ..59  
 Memory Alternate Control Register ..... 62, 136  
 Memory Bank x Control Register .....60  
 Memory Timing Control Register .....61  
 MMU Expanded Code Register .....61  
 MMU Instruction/Data Register .....58  
 RAM Segment Register .63  
 Segment Size Register ...60  
 Stack High Limit Register .....68  
 Stack Limit Control Register .....67  
 Stack Low Limit Register .....67  
 Stack Segment High Register .....59  
 Stack Segment Low Register .....59  
 Stack Segment Register .58  
 Write Protect Segment x High Register .....67  
 Write Protect Segment x Low Register .....66  
 Write Protect Segment x Register .....66  
 Write Protect x Register 65  
 Write Protection Control Register .....64

registers (continued)	
Network Port B .....	248
Enable Network Port	
Register .....	268
Network Port B Collision	
Window Register .....	263
Network Port B Command	
Register .....	257
Network Port B Configuration 0	
Register .....	261
Network Port B Configuration 1	
Register .....	261
Network Port B Configuration 2	
Register .....	262
Network Port B Configuration 3	
Register .....	262
Network Port B Control/	
Status Register .....	256
Network Port B Data	
Register .....	255
Network Port B Direct MII	
Register .....	260
Network Port B Direct Rx	
Register .....	260
Network Port B Direct Tx	
Register .....	260
Network Port B Frame	
Limit LSB Register ..	264
Network Port B Frame	
Limit MSB Register .	264
Network Port B Gap 0	
Register .....	263
Network Port B Gap 1	
Register .....	263
Network Port B Gap 2	
Register .....	263
Network Port B Last Data	
Register .....	255
Network Port B MII	
Command Register ...	266
Network Port B MII Configuration	
Register .....	264
Network Port B MII PHY	
Address Register .....	266
Network Port B MII Read	
LSB Register .....	266
Network Port B MII Read	
MSB Register .....	267
Network Port B MII Register	
Address Register .	266
Network Port B MII Reset	
Register .....	264
Network Port B MII Status	
Register .....	267
Network Port B MII Write	
LSB Register .....	266
Network Port B MII Write	
MSB Register .....	266

registers	
Network Port B (continued)	
Network Port B Multicast	
Filter x Register .....	259
Network Port B Physical	
Address x Register ...	259
Network Port B Receive	
Control Register .....	258
Network Port B Retransmit	
Max Register .....	263
Network Port B Station	
Address x Register ...	267
Network Port B Transmit	
Control Register .....	258
Network Port B Transmit	
Extra Status Register	259
Network Port B Transmit	
Pause LSB Register ..	257
Network Port B Transmit	
Pause MSB Register .	257
Network Port B Transmit	
Status Register .....	255
Network Port C .....	271
Parallel Port A .....	77
Parallel Port A Data	
Register .....	79
Slave Port Control Register	
.....	79
Parallel Port B .....	82
Parallel Port B Data	
Direction Register .....	83
Parallel Port B Data	
Register .....	83
Slave Port Control Register	
.....	84
Parallel Port C .....	86
Parallel Port C Alternate	
High Register .....	89
Parallel Port C Alternate	
Low Register .....	88
Parallel Port C Data	
Direction Register .....	88
Parallel Port C Data	
Register .....	88
Parallel Port C Drive	
Control Register .....	89
Parallel Port C Function	
Register .....	89
Parallel Port D .....	96
Parallel Port D Alternate	
High Register .....	100
Parallel Port D Alternate	
Low Register .....	99

registers	
Parallel Port D (continued)	
Parallel Port D Bit 0	
Register .....	101
Parallel Port D Bit 1	
Register .....	101
Parallel Port D Bit 2	
Register .....	102
Parallel Port D Bit 3	
Register .....	102
Parallel Port D Bit 4	
Register .....	102
Parallel Port D Bit 5	
Register .....	102
Parallel Port D Bit 6	
Register .....	103
Parallel Port D Bit 7	
Register .....	103
Parallel Port D Control	
Register .....	100
Parallel Port D Data	
Direction Register ....	101
Parallel Port D Data	
Register .....	99
Parallel Port D Drive	
Control Register .....	101
Parallel Port D Function	
Register .....	101
Parallel Port E .....	114
Parallel Port E Alternate	
High Register .....	117
Parallel Port E Alternate	
Low Register .....	116
Parallel Port E Bit 0	
Register .....	118
Parallel Port E Bit 1	
Register .....	118
Parallel Port E Bit 2	
Register .....	119
Parallel Port E Bit 3	
Register .....	119
Parallel Port E Bit 4	
Register .....	119
Parallel Port E Bit 5	
Register .....	119
Parallel Port E Bit 6	
Register .....	120
Parallel Port E Bit 7	
Register .....	120
Parallel Port E Control	
Register .....	117
Parallel Port E Data	
Direction Register ....	118
Parallel Port E Data	
Register .....	116

registers

- Parallel Port E (continued)
  - Parallel Port E Drive
    - Control Register ..... 118
  - Parallel Port E Function
    - Register ..... 118
- Parallel Port H ..... 132
  - Parallel Port D Alternate
    - Low Register ..... 134
  - Parallel Port H Alternate
    - High Register ..... 135
  - Parallel Port H Data
    - Direction Register ..... 136
  - Parallel Port H Data
    - Register ..... 134
  - Parallel Port H Drive
    - Control Register ..... 135
  - Parallel Port H Function
    - Register ..... 135
- PWM ..... 297
  - PWM Block Access
    - Register ..... 301
  - PWM Block Pointer
    - Register ..... 301
  - PWM LSB 0 Register .. 300
  - PWM LSB 1 Register .. 300
  - PWM LSB x Register .. 301
  - PWM MSB x Register .. 301
- Quadrature Decoder ..... 289
  - Quad Decode Control
    - Register ..... 106, 293
  - Quad Decode Control/
    - Status Register ..... 292
  - Quad Decode Count High
    - Register ..... 293
  - Quad Decode Count
    - Register ..... 293
- quadrature Decoder
  - Quad Decode Control
    - Register ..... 123
- reset ..... 26
  - reset/bootstrap
    - Slave Port Control Register
      - ..... 32
- Serial Ports A – D ..... 162
  - Serial Port x Address
    - Register ..... 168
  - Serial Port x Control Register
    - ..... 90, 104, 121, 171
  - Serial Port x Data Register
    - ..... 168
  - Serial Port x Divider High
    - Register ..... 174
  - Serial Port x Divider Low
    - Register ..... 173

registers

- Serial Ports A – D (continued)
  - Serial Port x Extended
    - Register (asynch mode)
      - ..... 172
  - Serial Port x Extended
    - Register (clocked serial
      - mode) ..... 173
  - Serial Port x Long Stop
    - Register ..... 168
  - Serial Port x Status Register
    - (asynch mode) ..... 169
  - Serial Port x Status Register
    - (clocked serial mode) 170
- Serial Ports E – F ..... 177
  - Serial Port x Address
    - Register ..... 185
  - Serial Port x Control
    - Register ..... 188
  - Serial Port x Data Register
    - ..... 185
  - Serial Port x Divider High
    - Register ..... 190
  - Serial Port x Divider Low
    - Register ..... 190
  - Serial Port x Extended Reg-
    - ister (asynch mode) ... 189
  - Serial Port x Extended Reg-
    - ister (HDLC mode) ... 190
  - Serial Port x Long Stop
    - Register ..... 185
  - Serial Port x Status Register
    - (asynch mode) ..... 186
  - Serial Port x Status Register
    - (HDLC mode) ..... 187
- slave port ..... 192
  - Slave Port Control Register
    - ..... 127, 201
  - Slave Port Data x Registers
    - ..... 200
  - Slave Port Status Register
    - ..... 200
- system management ..... 35
  - Battery-Backed Onchip-
    - Encryption RAM ..... 43
  - Global Control/Status
    - Register ..... 39
  - Global CPU Register ..... 42
  - Global Output Control
    - Register ..... 42
  - Global RAM Configuration
    - Register ..... 41
  - Global Revision Register 42
  - Global ROM Configuration
    - Register ..... 41

registers

- system management (cont'd)
  - Real-Time Clock Control
    - Register ..... 40
  - Real-Time Clock x Register
    - ..... 40
  - Secondary Watchdog Timer
    - Register ..... 41
  - Watchdog Timer Control
    - Register ..... 40
  - Watchdog Timer Test
    - Register ..... 41
  - System/User mode ..... 340
    - Analog User Enable
      - Register ..... 353
    - Enable Dual-Mode Register
      - ..... 355
    - External Interrupt User
      - Enable Register ..... 353
    - I/O Bank User Enable
      - Register ..... 352
    - Input Capture User Enable
      - Register ..... 351
    - Parallel Port A User Enable
      - Register ..... 350
    - Parallel Port B User Enable
      - Register ..... 350
    - Parallel Port C User Enable
      - Register ..... 351
    - Parallel Port D User Enable
      - Register ..... 351
    - Parallel Port E User Enable
      - Register ..... 351
    - Parallel Port H User Enable
      - Register ..... 350
    - PWM User Enable Register
      - 352
    - Quad Decode User Enable
      - Register ..... 352
    - Real-Time Clock User
      - Enable Register ..... 350
    - Serial Port A User Enable
      - Register ..... 354
    - Serial Port B User Enable
      - Register ..... 354
    - Serial Port C User Enable
      - Register ..... 354
    - Serial Port D User Enable
      - Register ..... 354
    - Serial Port E User Enable
      - Register ..... 355
    - Serial Port F User Enable
      - Register ..... 355
    - Slave Port User Enable
      - Register ..... 350
    - Timer A User Enable
      - Register ..... 353

registers	
System/User mode (cont'd)	
Timer B User Enable	
Register	353
Timer C User Enable	
Register	354
Timer A	140
Global Control/Status	
Register	144
Timer A Control Register	
	143
Timer A Control/Status	
Register	142
Timer A Prescale Register	
	142
Timer A Time Constant x	
Register	143
Timer B	146
Global Control/Status	
Register	150
Timer B Control Register	
	148
Timer B Control/Status	
Register	148
Timer B Count LSB	
Register	150
Timer B Count LSB x	
Register	149
Timer B Count MSB	
Register	149
Timer B Count MSB x	
Register	149
Timer B Step LSB x	
Register	149
Timer B Step MSB x	
Register	149
Timer C	153
Global Control/Status	
Register	158
Timer C Block Access	
Register	157
Timer C Block Pointer	
Register	158
Timer C Control Register	
	156
Timer C Control/Status	
Register	156
Timer C Divider High	
Register	156
Timer C Divider Low	
Register	156
Timer C Reset x High	
Register	157
Timer C Reset x Low	
Register	157
Timer C Set x High Register	
	157
Timer C Set x Low Register	
	157

reset	25
block diagram	26
dependencies	27
operation	28
register descriptions	32
registers	26
SMODE pin settings	29

## S

serial ports	
clock synchronization and data	
encoding	181
Serial Ports A – D	159
block diagram	161
clocks	163
data clocks	160
dependencies	163
interrupts	164
operation	165
asynchronous mode	165
clocked serial mode	
	160, 166
overview	159
pin use	163
register descriptions	168
registers	162
SPI clock modes	159
SxSR	159
use of clocked Serial Port C	
	163
use of clocked Serial Port D	
	163
Serial Ports E – F	175
asynchronous mode	175
block diagram	176
clocks	178
dependencies	178
HDLC data encoding	182
HDLC mode	175
DPLL counter	182
interrupts	179
operation	180
asynchronous mode	180
HDLC mode	180
overview	175
pin use	178
register descriptions	185
registers	177
SxSR	175

slave port	81, 191
addresses	191
block diagram	192
bootstrap processor	192
clocks	193
dependencies	193
interrupts	191, 193, 196
example ISR	196
operation	194
configurations	197
connections	195
master	195
master/slave communication	196
slave	195
slave/master communication	196
overview	191
pin use	193
R/W timing	198
register descriptions	200
registers	192
slave attention	191
timing diagrams	198
sleepy clock modes	19
SMODE pin settings	29
SPCR	
Parallel Port A setup	77
specifications	5, 357
AC characteristics	359
analog components	204
BGA package	375
dimensions	377
land pattern	377
pinout	375, 376
clock speeds	368
recommended clock/memory configurations	368
DC characteristics	357
memory access times	360, 365
external I/O reads	363
external I/O writes	363
memory reads	360
memory writes	360
package	375
power and current consumption	372
battery-backed clock	374
sleep modes	373
spectrum spreader	9, 13

stack protection .....	57
system management .....	33
block diagram .....	34
clocks .....	36
dependencies .....	36
interrupts .....	36
onchip-encryption RAM .....	33
operation	
periodic interrupt .....	37
real-time clock .....	37
watchdog timer .....	38
other registers .....	33
GCPU register .....	33
GOCR register .....	33
GREV register .....	33
periodic interrupt .....	33
real-time clock .....	33
register descriptions .....	39
registers .....	35
watchdog timers .....	33
System/User mode .....	339
dependencies .....	341
differences between System	
mode and User mode .....	339
inaccessible addresses in User	
mode .....	341
interrupts .....	342, 348
opcodes .....	346
operation .....	343
complete operating system	
.....	344
enabling .....	345
memory protection .....	343
mixed operation .....	344
overview .....	339
register descriptions .....	350
registers .....	340
use	
memory protection .....	343

## T

timers	
Timer A .....	137
block diagram .....	139
capabilities .....	138
clocks .....	140
dependencies .....	140
interrupts .....	138, 141
example ISR .....	141
operation .....	141
overview .....	137
register descriptions .....	142
registers .....	140
reload register operation .....	137
Timer B .....	145
block diagram .....	145
clocks .....	146
dependencies .....	146
interrupts .....	146, 147
example ISR .....	147
operation .....	147
overview .....	145
PWM operation .....	145
register descriptions .....	148
registers .....	146
Timer C .....	151
block diagram .....	152
clocks .....	154
dependencies .....	154
DMA control .....	151
interrupts .....	154, 155
example ISR .....	155
operation .....	155
overview .....	151
register descriptions .....	156
registers .....	153

## timing diagrams

I/O R/W cycles .....	364
memory R/W cycles .....	361
memory R/W cycles (early	
output enable and write	
enable) .....	362
slave port R/W cycles	
.....	198, 199

## W

watchdog timer	
primary watchdog timer .....	38
primary/secondary watchdog	
timer bug .....	38
secondary watchdog timer .....	38
settings .....	38